









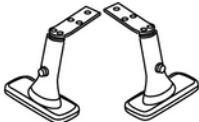
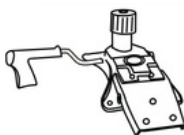

Ergo3D Ergonomic Mesh Office Chair

Parts Listing

- | | | |
|---|--|---|
| (1)
Chair Back
x1
 | (2)
Chair Seat
x1
 | (3)
Arms
x1(L) x1(R)
 |
| (4)
Seat Mechanism
x1
 | (5)
Gas Lift
x1
 | (6)
Chair Base
x1
 |
| (7)
Casters
x5
 | (8)
Screws
x4
M6x0.79"
 | (9)
Screws
x3
M8x0.79"
 |
| (10)
Screws
x6
M6x1.18"
 | (11)
Headrest
x1
 | (12)
Screws
x2
M6x0.79"
 |
| (13)
Allen Wrench
x1
 | | |

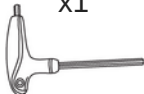
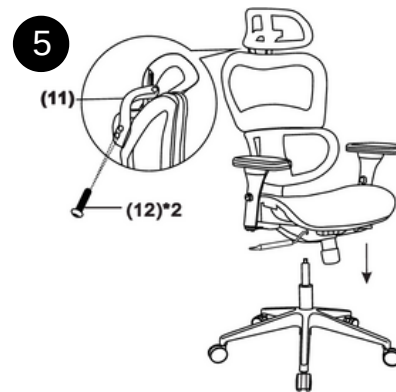
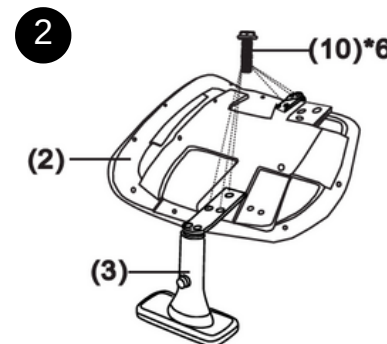
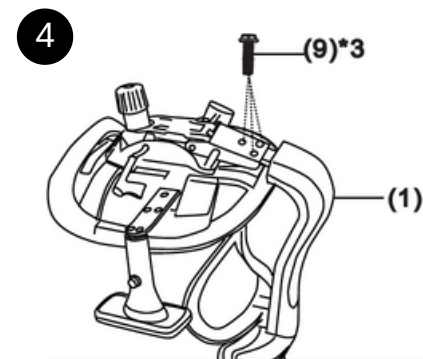
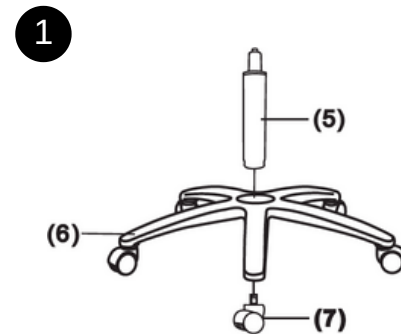
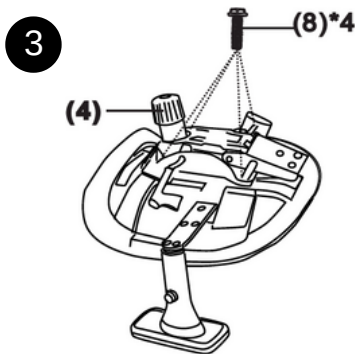

Assembly Instructions



Tools Needed: Allen Wrench - Provided

Please read all instructions before assembly.

Step 1: Insert Casters (7) into Chair Base (6). Insert Gas Lift (5) into the hole in the center of the Chair Base (6).

Step 2: Attach Arms (3) to both sides of the Chair Seat (2) using M6x1.18" Screws (10). Tighten with Allen Wrench (13).

Step 3: Attach Seat Mechanism (4) using M6x0.79" Screws (8). Tighten with Allen Wrench (13).

Step 4: Attach Chair Back (1) to Chair Seat using M8x0.79" Screws (9). Tighten with Allen Wrench (13).

Step 5: Carefully place the assembled Chair Frame onto the Gas Lift (5). Aligning the hole into the Seat Mechanism on the Chair Seat (2) with the Gas Lift (5). Press down on the Chair Seat (2) to secure in place. Attach Headrest (11) to Chair Back, using two M6x0.79" Screws (12). Tighten with Allen Wrench (13).

WEIGHT CAPACITY: 275 lbs.

Assembly Notes:

During assembly, hand tighten screw only when all screws are in place, you may tighten all screws completely.

CAUTION:

1. Do not use this chair as a step ladder.
2. Check for loose screw and tighten them every 6 months.

NOUHAUS

Life Curation

2530 Corporate Pl. #A112
Monterey Park, CA 91754
United States
www.nouhaus.com
shop@nouhaus.com