

Assembly Instructions









QUEEN HEADBOARD - UPH QUEEN FOOTBOARD QUEEN/ KING RAILS

Thank you for purchasing this quality product. Be sure to check all packing material carefully for small parts, which may have come loose inside the carton during shipment. Identify, count all parts and compare with the HARDWARE LIST below.











Caution: Please read the instructions thoroughly before assembly.

1. We recommend that you assemble this product with the assistance of another person; this will make the assembly easier, and will help eliminate damage to the product or injury to persons during assembly.
2. Please do not over tighten screws or bolts until the assembly is completed.
3. Please put all parts on a non-abrasive floor before assembly, and follow the assembly steps to assemble your newly purchased product correctly and efficiently.

PART LIST

NO:	SKETCH	DESCRIPTION	Q'TY
A		Head Board	1 Pc
B		Head Board Foot (L-R)	2 Pcs
C		Foot Board	1 Pc
D		Side Rail	2 Pcs
E		Slats	4 Pcs
F		Support With Leveler	8 Pcs
G		HB Bottom Rail	1 Pc
H		Cap Rail	2Pcs

HARDWARE LIST

NO:	SKETCH	DESCRIPTION	Q'TY
1		Screw: # 8 X 30mm	8Pcs
2		Allen Key	1Pc
3		Hex Nut	8Pcs
4		U Washer	8Pcs
5		Thread Bolt	8Pcs
6		Allen Key	1Pc
7		JCBC Bolt 5/16" x 65mm	6Pcs
8		Spring Washer 5/16" Dia	8Pcs
9		Flat Washer 5/16" Dia	8Pcs
10		JCBC Bolt 5/16" x 40mm	2Pcs
11		JCBC Bolt 1/4" x 40mm	8Pcs

HARDWARE/ PART LIST LOCATION

QUEEN HEADBOARD- UPH > Step 1 > hardware No 6, 7, 8, 9, 10 > put inside a red pack with red tape > Place in the right bottom corner of headboard carton

- > Part G (HB bottom rail) > Place in Head board carton
- > part B (Head board Foot (L-R)) > place in Head board carton with a small box

QUEEN/KING RAILS > Hardware No. 1, 2, 3, 4, 5 > put inside a red pack with red tape > Place between the space of two side rails

- > Step 3 part F (Support with leveler) was wrapped and place in footboard carton

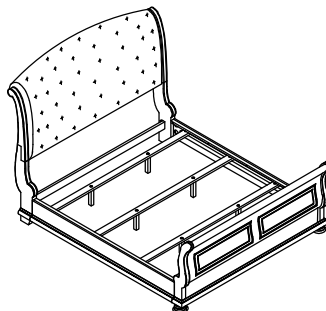

Assembly Instructions

QUEEN HEADBOARD
QUEEN FOOTBOARD
QUEEN/ KING RAILS

STEP1

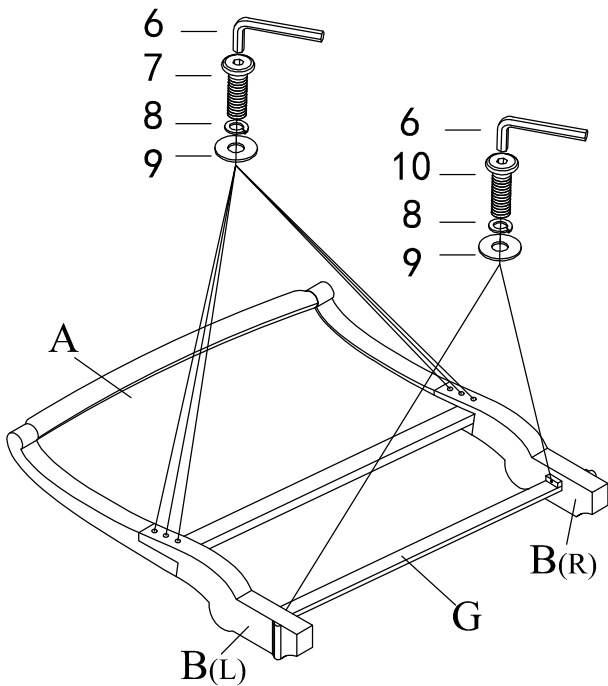

STEP2

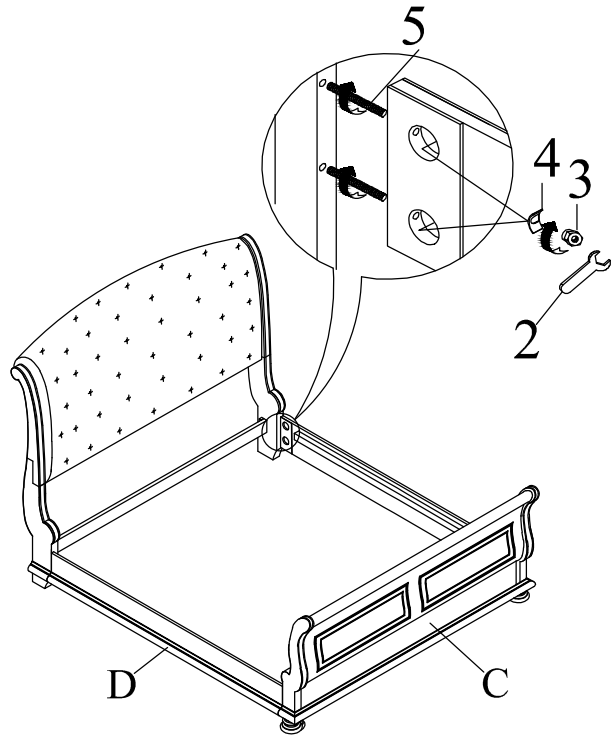

STEP3

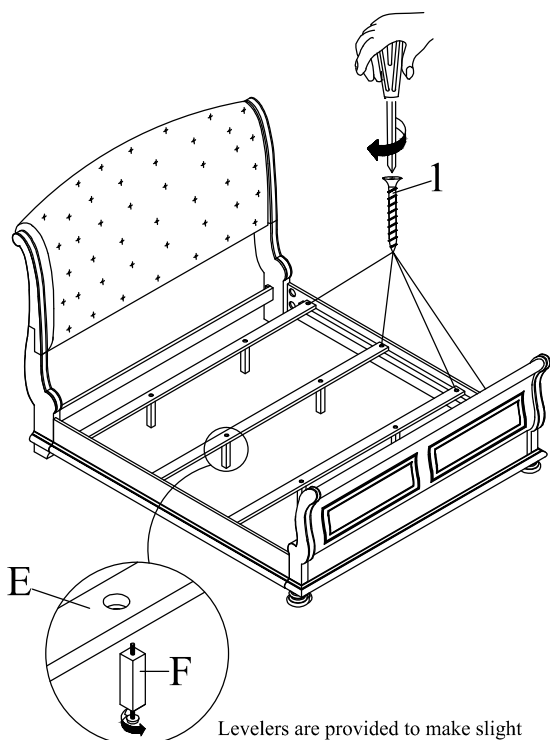

Levelers are provided to make slight adjustments to level the product as floors are often not level in homes.

STEP4

