

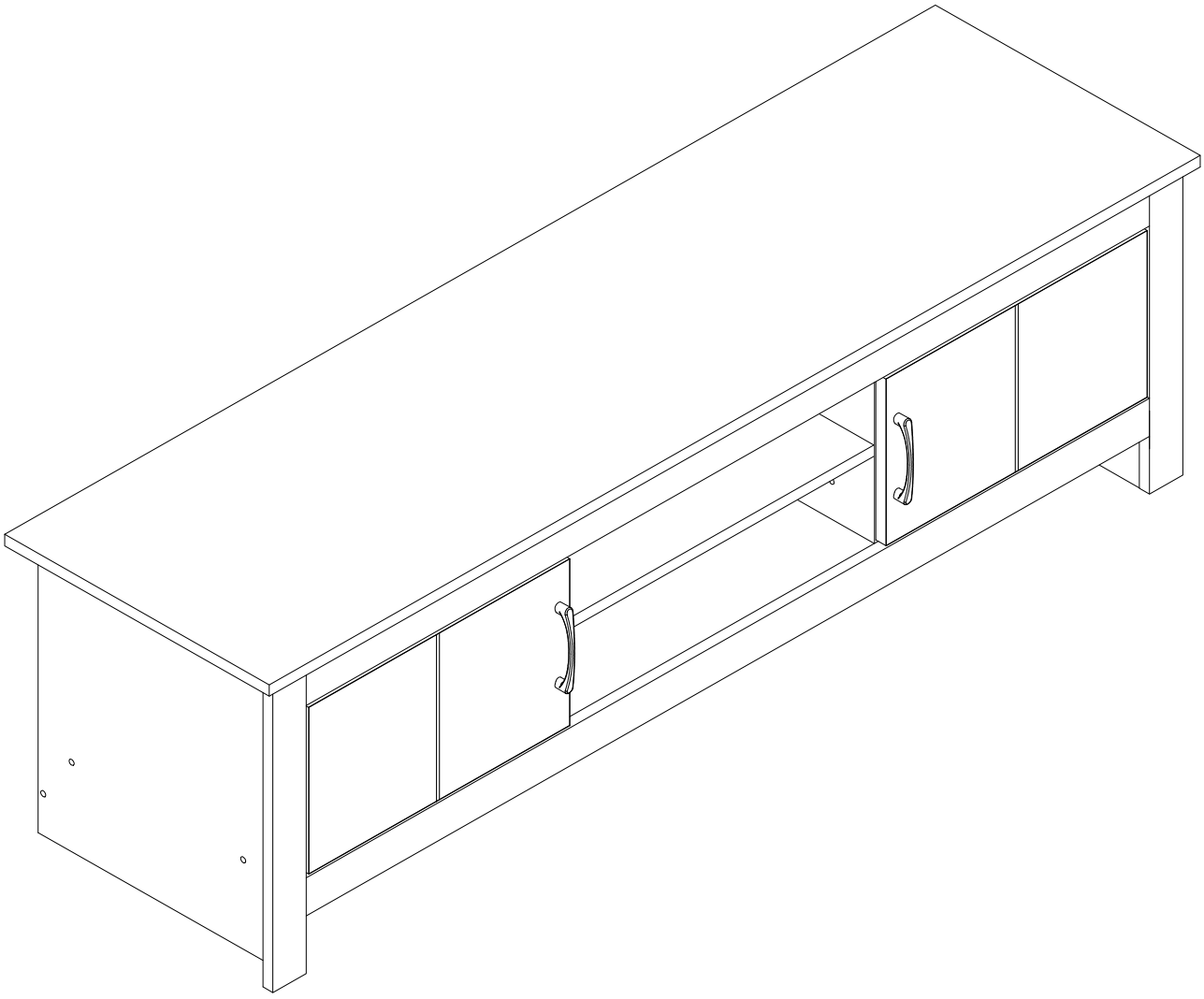





**ASSEMBLY INSTRUCTIONS / INSTRUCTIONS  
D'ASSEMBLAGE / INSTRUCTIVO DE ARMADO**



## NOTES ON ASSEMBLY / NOTES POUR L'ASSEMBLAGE / NOTAS SOBRE EL ENSAMBLE

- To ensure ease of assembly read all instructions before assembly and follow step by step illustrations.
- Keep instructions for future use.
- Adult assembly required.  2 person required. 
- Due to the presence of small parts during assembly, keep out of reach of children until assembly is complete.

- Pour assurer l'assemblage facile veuillez lire toutes les instructions avant l'assemblage et veuillez suivre les illustrations pour chaque etapes.
- Veuillez garder ces instructions pour l'usage ulterieur.
- Assemblage requis pas un adulte.  2 personnes requises. 
- Due a la presence de petite pieces durant l'assemblage, veuillez garder hors de porter des enfants jusqu'a ce que l'assemblage soit completer.

- Para garantizar la facilidad de ensamble lea las instrucciones antes de iniciar y siga paso a paso las ilustraciones.
- Guarde las instrucciones para futuras referencias.
- El ensamble requiere de un adulto.  2 personas requeridas. 
- Debido a que hay piezas pequeñas, mantenga fuera del alcance a los niños durante el ensamble, hasta que haya terminado.

## MAINTENANCE TIPS / CONSEILS D'ENTRETIEN / CONSEJOS DE MANUTENIMIENTO

- Never let liquids or damp cloths sit on this furniture.
- Never use chemical cleaning products. They can damage the finish. For cleaning, use only a slightly damp cloth and wipe dry.
- To avoid dulling of the finish, do not place furniture in direct sunlight.
- Do not put plastic or rubber rings under appliances. Use cloth of felt protectors.
- To clean, use a soft or slightly damp cloth, then wipe with a clean, dry cloth.

- Ne jamais laisser de liquide ou linge humide sur le meuble.
- Ne jamais utiliser de nettoyeurs à base de produits chimiques, cela va endommager le fini. Utiliser seulement un linge légèrement humide.
- Ne pas placer le meuble directement au soleil pour prévenir le ternissement.
- Évitez de déposer des appareils avec des rondelles de plastique ou de caoutchouc. Utilisez un protecteur en tissu ou en feutre.
- Pour nettoyer, utilisez un linge doux ou légèrement humecté. Essayez par la suite avec un linge propre et sec.

- Nunca deje un líquido o un trapo húmedo sobre el mueble.
- Nunca utilice limpiadores a base de químicos, estos dañaran le acabado. Use sólo un paño húmedo.
- No esponga el mueble directamente al sol para prevenir empañamiento.
- Evite apoyar aparatos con redondeles de plástico o de goma. Utilizar un protector de tela o de fieltro.
- Para limpiar, utilice un trapo suave o ligeramente humedecido. Seque luego con un trapo limpio y seco.

# WARNING AVERTISSEMENT / ADVERTENCIA

Please use your furniture correctly and safely. Improper use can cause safety hazards, or damage to your furniture or household items.

Serious or fatal crushing injuries can occur from furniture tip-over.

To help prevent tip-over:

- It is important to place the safety bracket included.
- Place heaviest items in the lowest storage space.
- Never allow children to climb or hang on drawers, doors, or shelves.
- Never open more than one drawer at a time.
- If a heavy object is placed on top or inside the furniture, consider this risk.

Use of tip-over restraints reduce, but does not eliminate, the risk of tip-over.

Prière d'utiliser le mobilier à bon escient et avec prudence. Une mauvaise utilisation peut être à l'origine de risques d'accident ou peut endommager le mobilier et les articles ménagers.

Des blessures graves ou fatales peuvent résulter de basculement du meuble.

Afin de prévenir le basculement :

- Il est important d'installer le crochet de sécurité inclus.
- Placer les items les plus lourds dans les espaces de rangement du bas.
- Ne jamais laisser un enfant grimper sur les tiroirs, les portes et les tablettes ou s'accrocher à ceux-ci.
- Ne jamais ouvrir plus d'un tiroir à la fois.
- Si un objet lourd est placé sur l'unité ou à l'intérieur, considérez le risque de basculement.

L'utilisation de dispositif antibasculement ne peut que réduire les risques de basculement, sans les éliminer

Por favor use el mobiliario correcta y seguramente. El mal uso puede causar riesgos de seguridad o daño a las unidades o artículos domésticos.

El vuelco del mueble puede ser causa de lesiones graves o de un aplastamiento fatal.

Para evitar la volcadura:

- Es importante instalar el gancho de seguridad.
- Ponga las cosas pesadas en los compartimentos más bajos.
- Nunca permita que un niño se suba o se cuelgue en cajones, puertas o estantes.
- Nunca abra más de un cajón a la vez.
- Si un objeto pesado esta colocado dentro o sobre el mueble, considere el riesgo de que se puede voltear.

El uso de sujetadores para evitar el vuelco sólo puede disminuir el riesgo de un vuelco, pero no lo elimina.

**THINGS TO REMEMBER FOR ASSEMBLY**  
**CHOSSES À SE SOUVENIR POUR UNE ASSEMBLEE**  
**COSAS PARA RECORDAR EN UNA ASAMBLEA**

**MINIFIX BOLT**  
**BOULON MINIFIX**  
**PERNO MINIFIX**

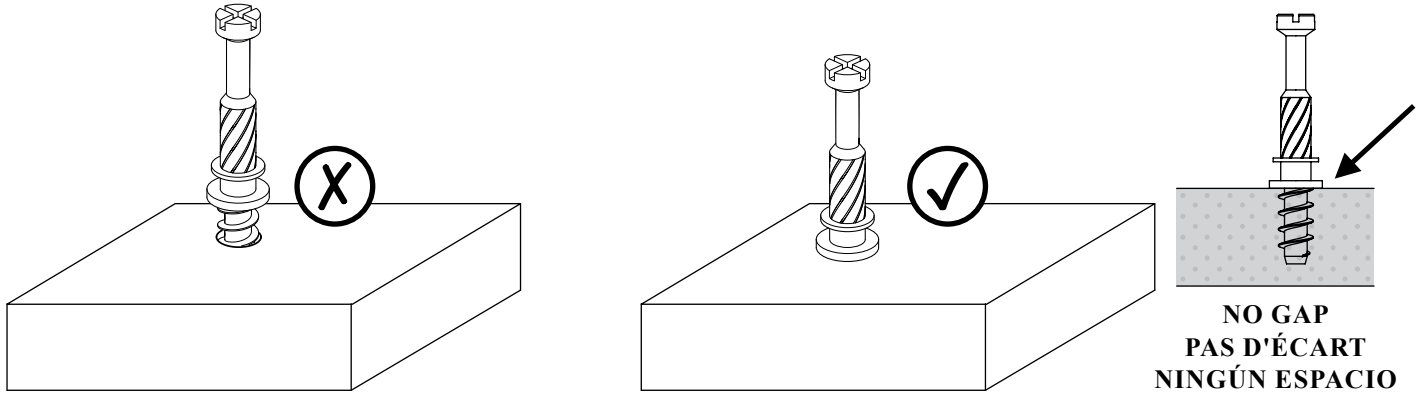

**MINIFIX CAM**  
**CAMÉRA MINIFIX**  
**CÁMARA MINIFIX**

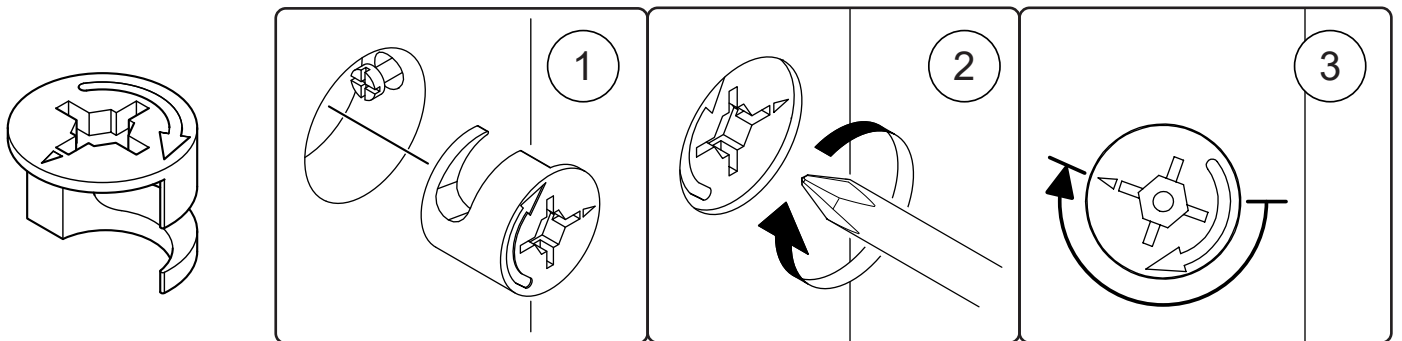



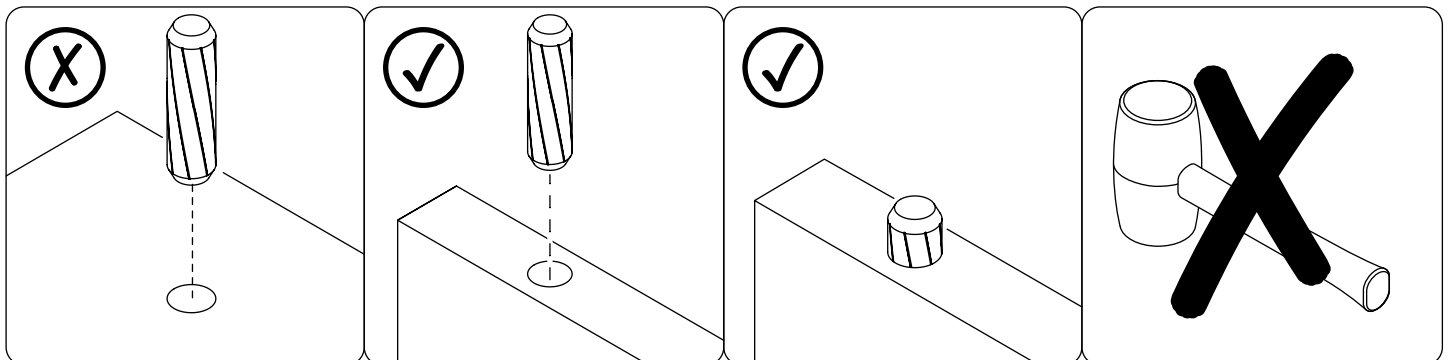



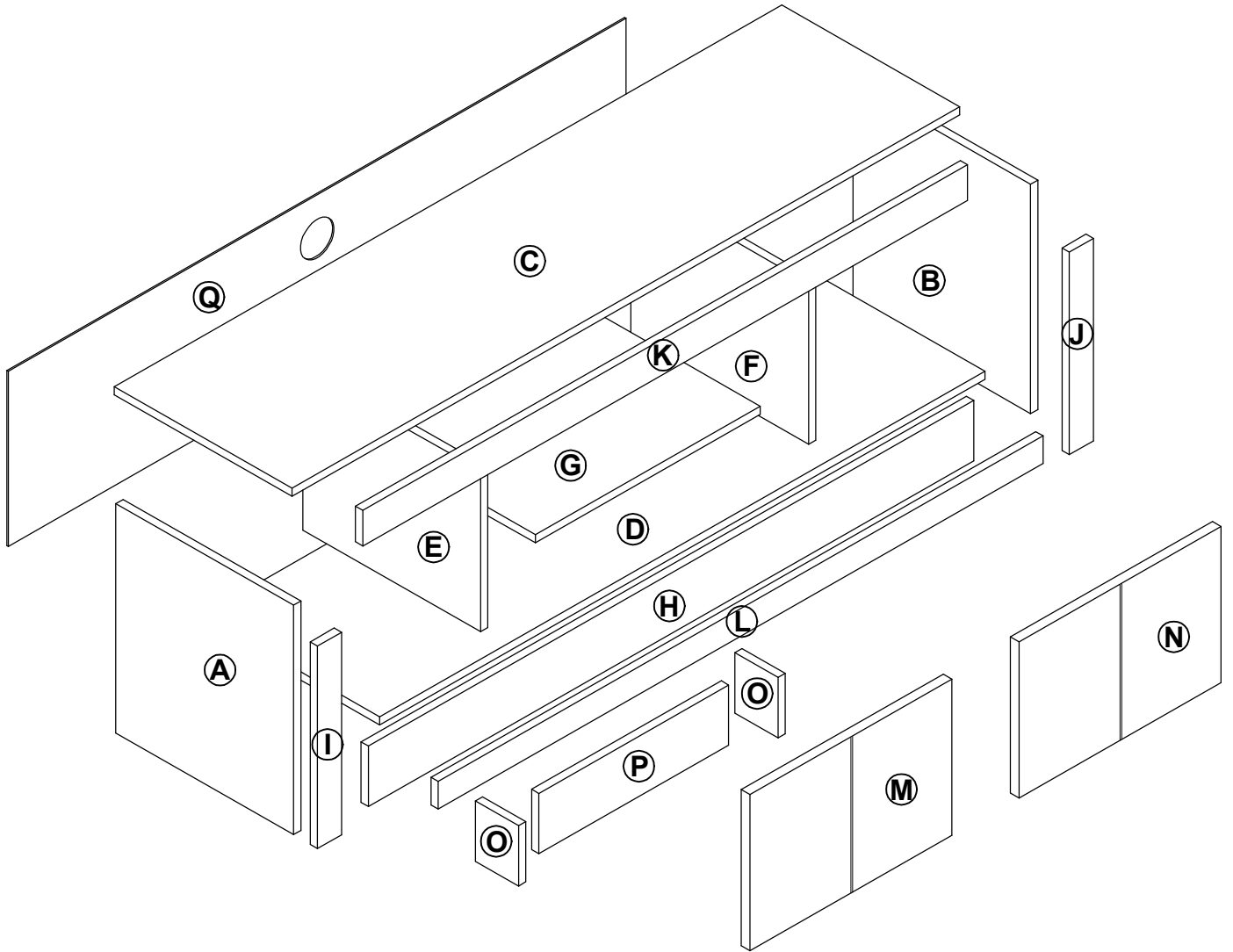



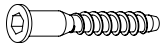

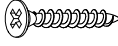

**WOOD DOWEL**  
**CHEVILLE BOIS**  
**PASADOR DE MADERA**

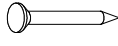

**PARTS IDENTIFICATION**  
**IDENTIFICATION DES PIÈCES**  
**IDENTIFICACIÓN DE LAS PARTES**

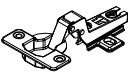

# HARDWARE QUINCAILLERIE / HERRAJE

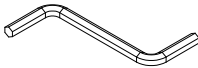
|     |                                                                                                                        |     |                                                                                                                  |     |                                                                                                                        |
|-----|------------------------------------------------------------------------------------------------------------------------|-----|------------------------------------------------------------------------------------------------------------------|-----|------------------------------------------------------------------------------------------------------------------------|
| (A) | Screw M6.3 x 40mm<br><br>14 units     | (B) | Minifix Bolt<br><br>15 units    | (C) | Dowel Ø8 x 30mm<br><br>38 + 2 units |
| (D) | Screw M4 x 30mm<br><br>4 units        | (E) | Screw M3.5 x 25mm<br><br>1 unit | (F) | Screw M3.5 x 15mm<br><br>10 units   |
| (G) | Screw #10 x 16mm<br><br>16 + 2 units  | (H) | Shelf Support<br><br>4 units    | (I) | Nail Pin<br><br>22 units            |
| (J) | Nail Leg<br><br>8 units               | (K) | Cam Bolt<br><br>15 units        | (L) | L-Bracket (2mm)<br><br>5 units      |
| (M) | Handle<br><br>2 units                 | (N) | Hinges 7/8"<br><br>4 units      | (O) | Seal Sticker<br><br>6 units         |
| (P) | Safety Strap + Washer<br><br>1 unit | (Q) | Allen Key M4<br><br>1 unit    |     |                                                                                                                        |

- Hardware quantity may supplied more than it required. Please keep spares and tools for future use.
- La cantidad de hardware puede suministrarse más de lo requerido. Guarde los repuestos y las herramientas para uso futuro.
- La quantité de matériel peut fournir plus que nécessaire. Veuillez conserver les pièces de rechange et les outils pour une utilisation future.

## TOOLS NOT INCLUDED OUTILS PAS INCLUS / HERRAMIENTAS NO INCLUIDAS

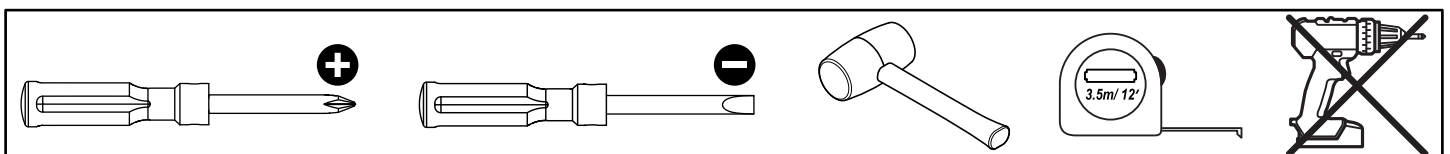

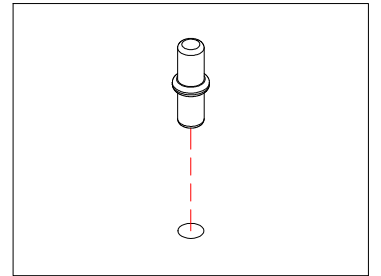
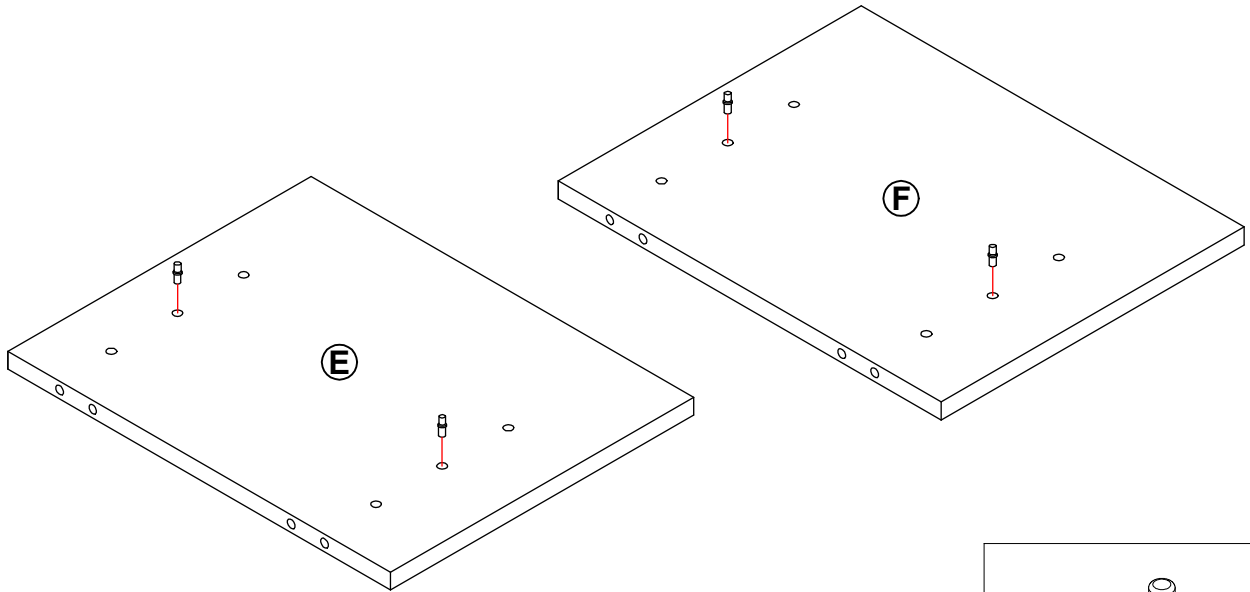
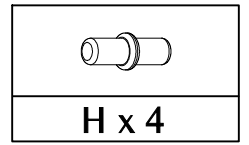

# Step 1

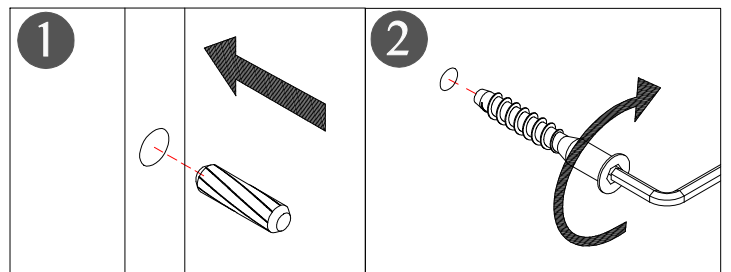
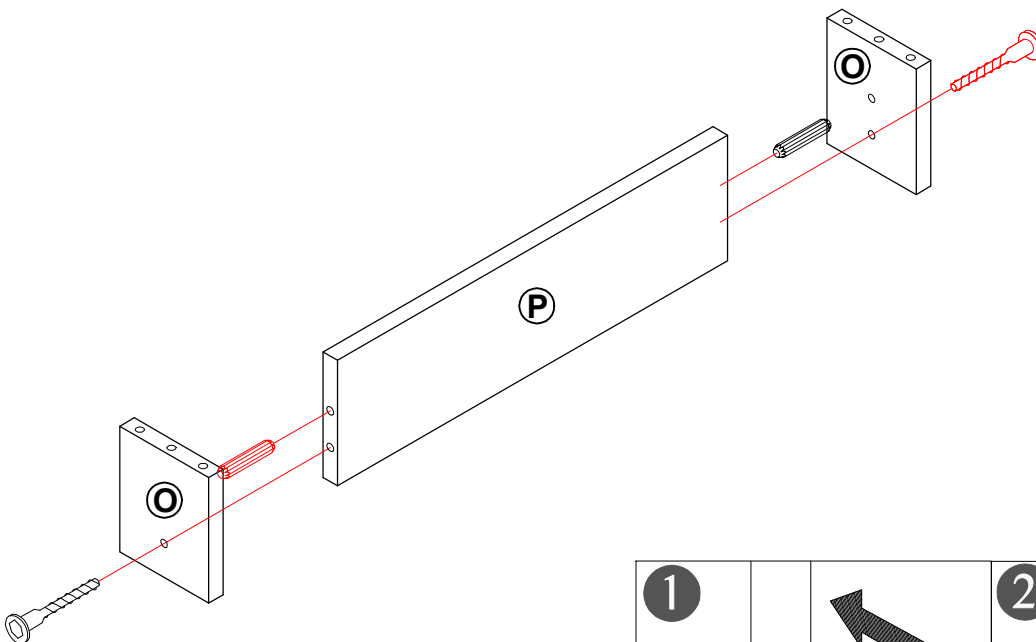
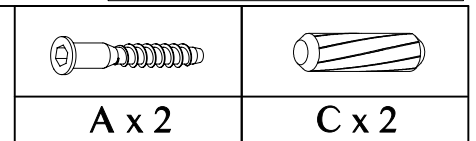

# Step 2

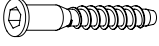

### Step 3

|                                                                                     |                                                                                     |
|-------------------------------------------------------------------------------------|-------------------------------------------------------------------------------------|
|  |  |
| <b>A x 2</b>                                                                        | <b>C x 4</b>                                                                        |

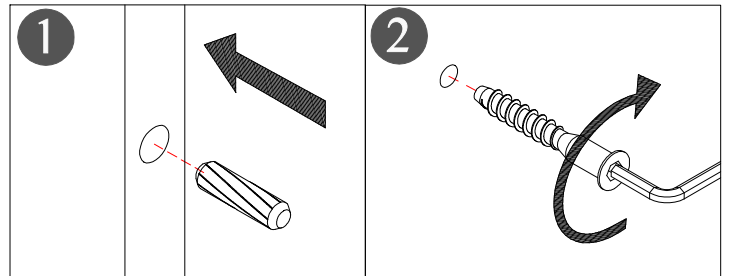
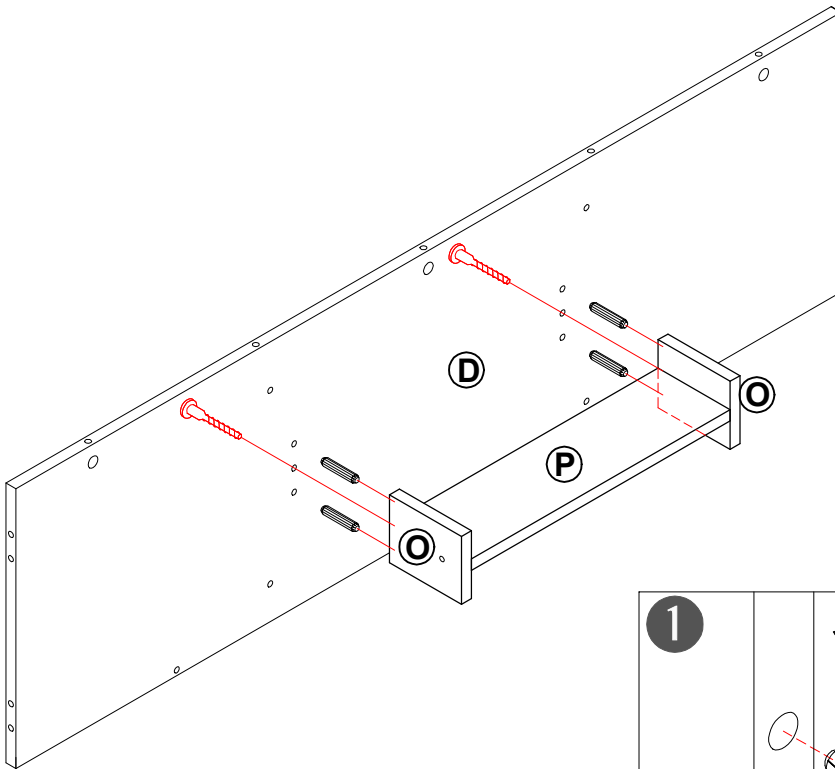

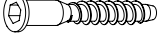
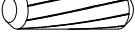

### Step 4

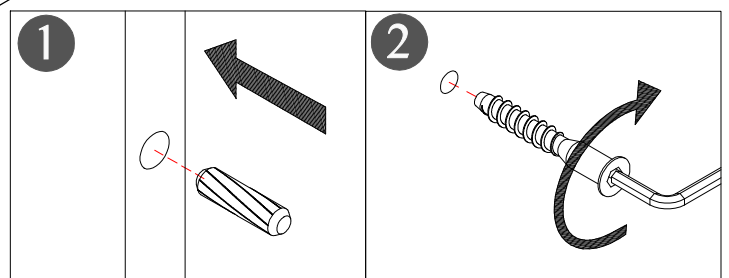
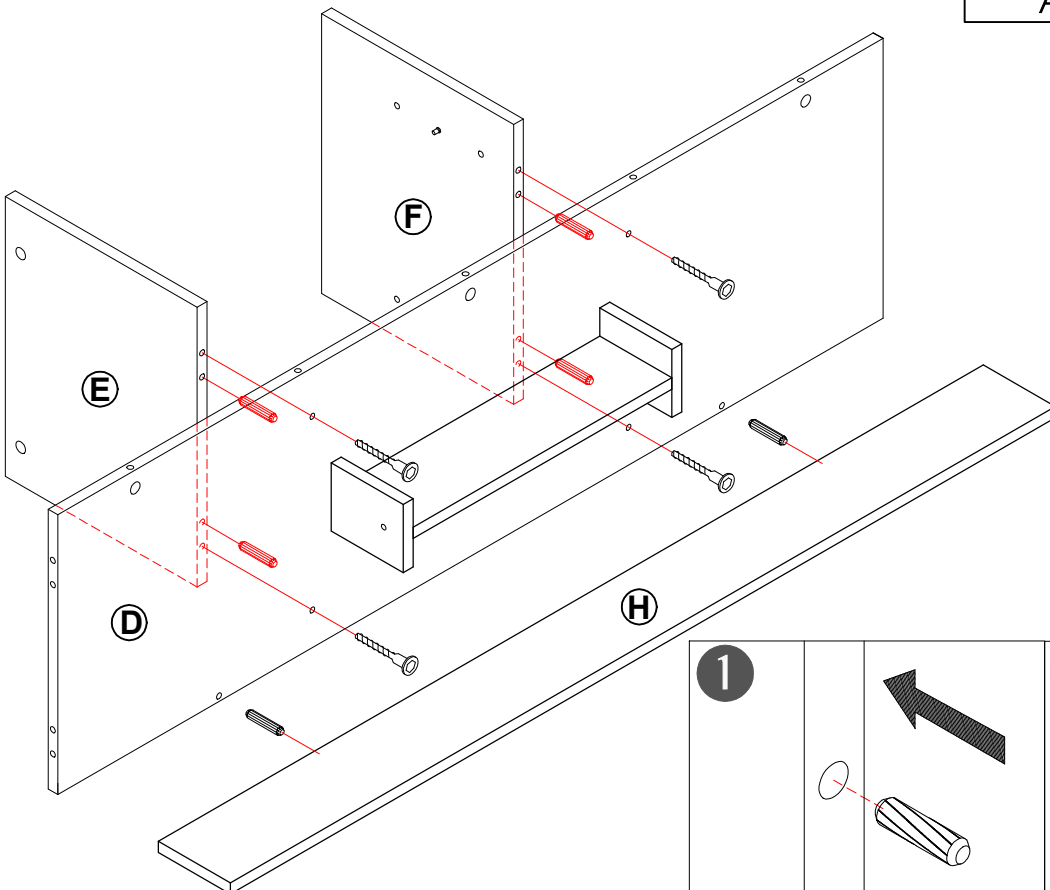
|                                                                                       |                                                                                       |
|---------------------------------------------------------------------------------------|---------------------------------------------------------------------------------------|
|  |  |
| <b>A x 4</b>                                                                          | <b>C x 6</b>                                                                          |



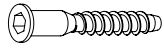

# Step 5

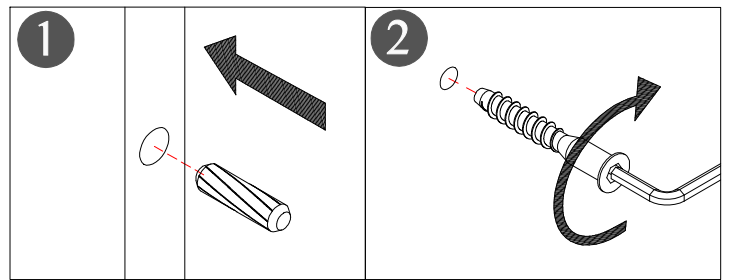
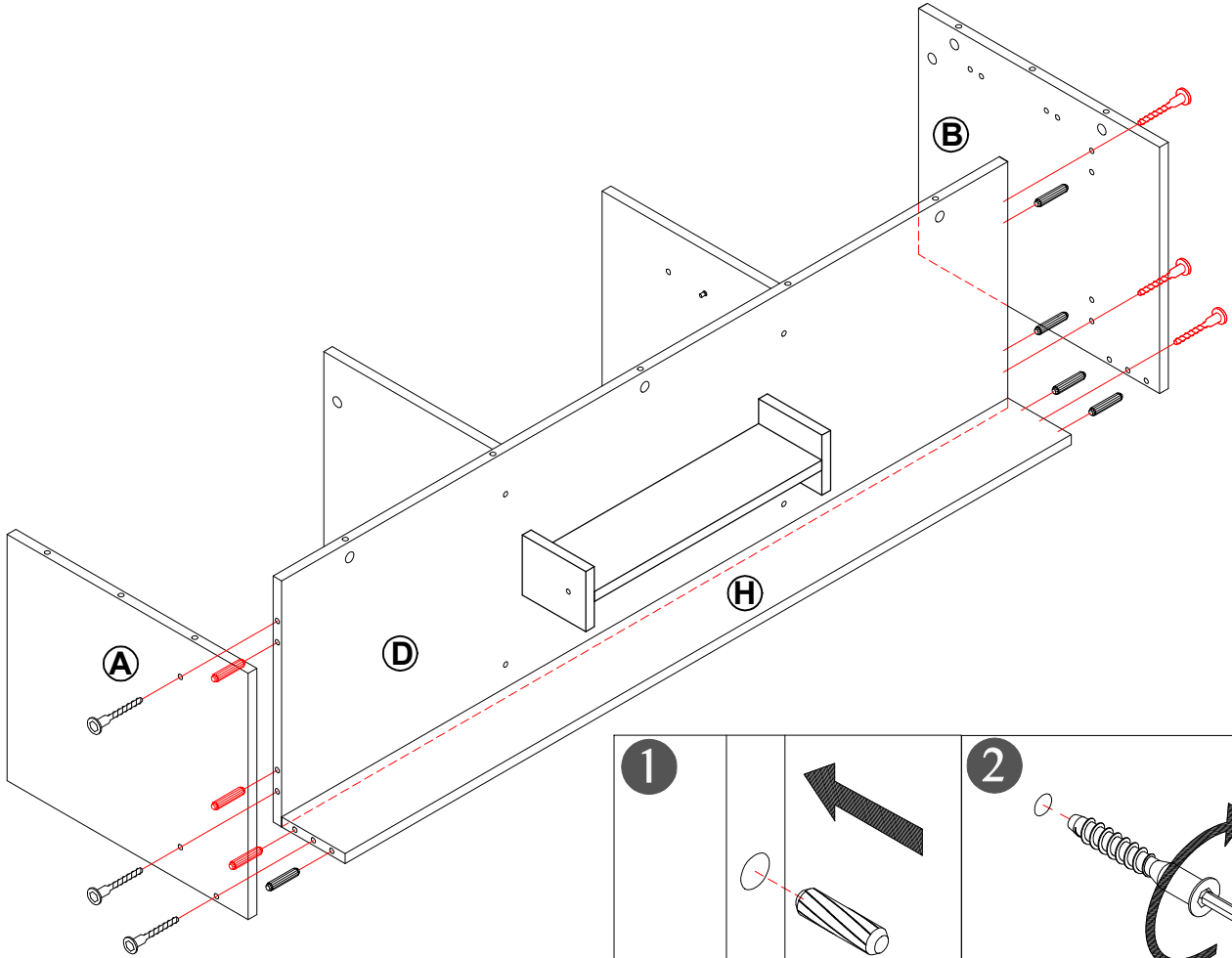
|                                                                                    |                                                                                    |
|------------------------------------------------------------------------------------|------------------------------------------------------------------------------------|
|  |  |
| <b>A x 6</b>                                                                       | <b>C x 8</b>                                                                       |



# Step 6

|                                                                                     |                                                                                       |                                                                                       |
|-------------------------------------------------------------------------------------|---------------------------------------------------------------------------------------|---------------------------------------------------------------------------------------|
|  |  |  |
| <b>F x 3</b>                                                                        | <b>L x 3</b>                                                                          | <b>B x 7</b>                                                                          |

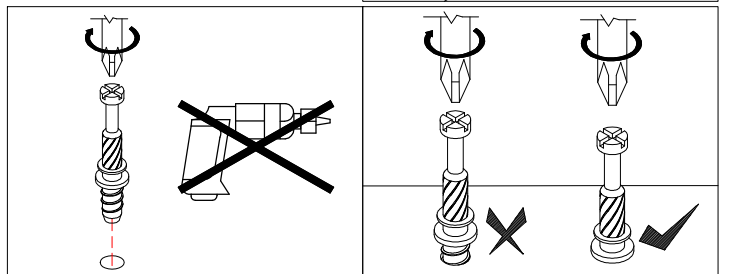
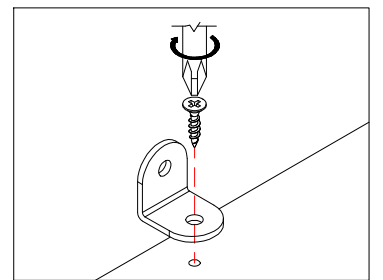
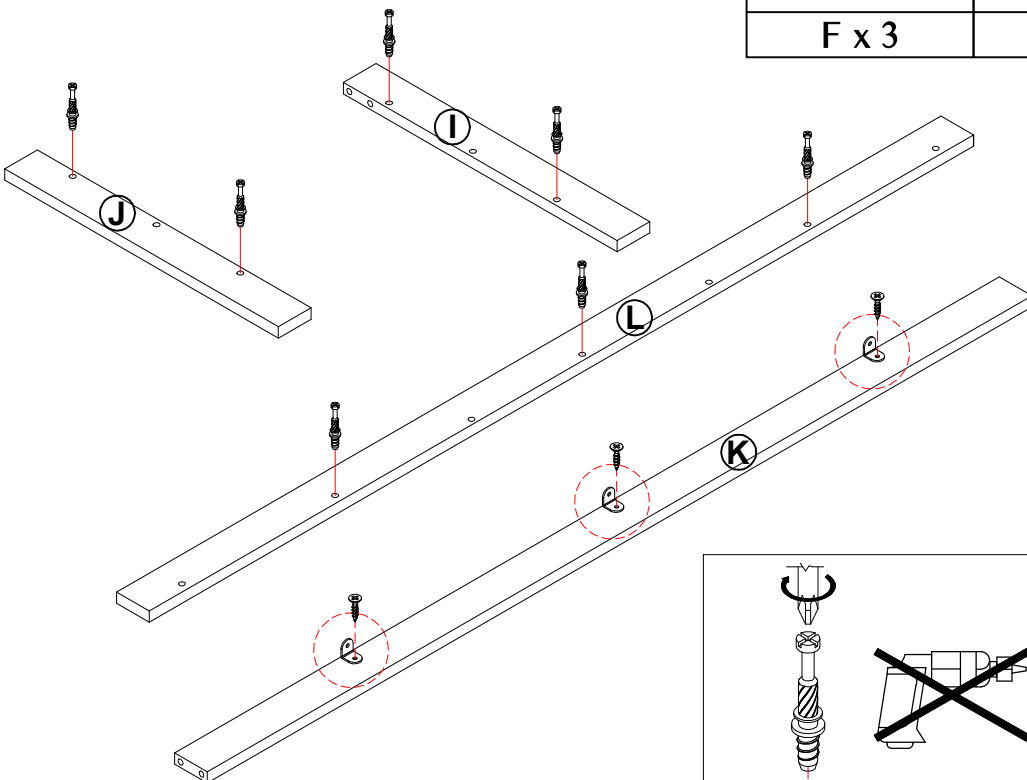

# Step 7

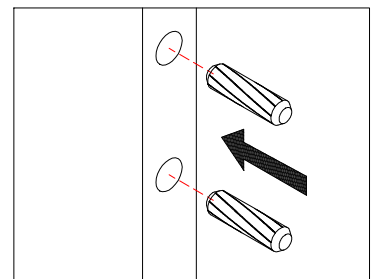
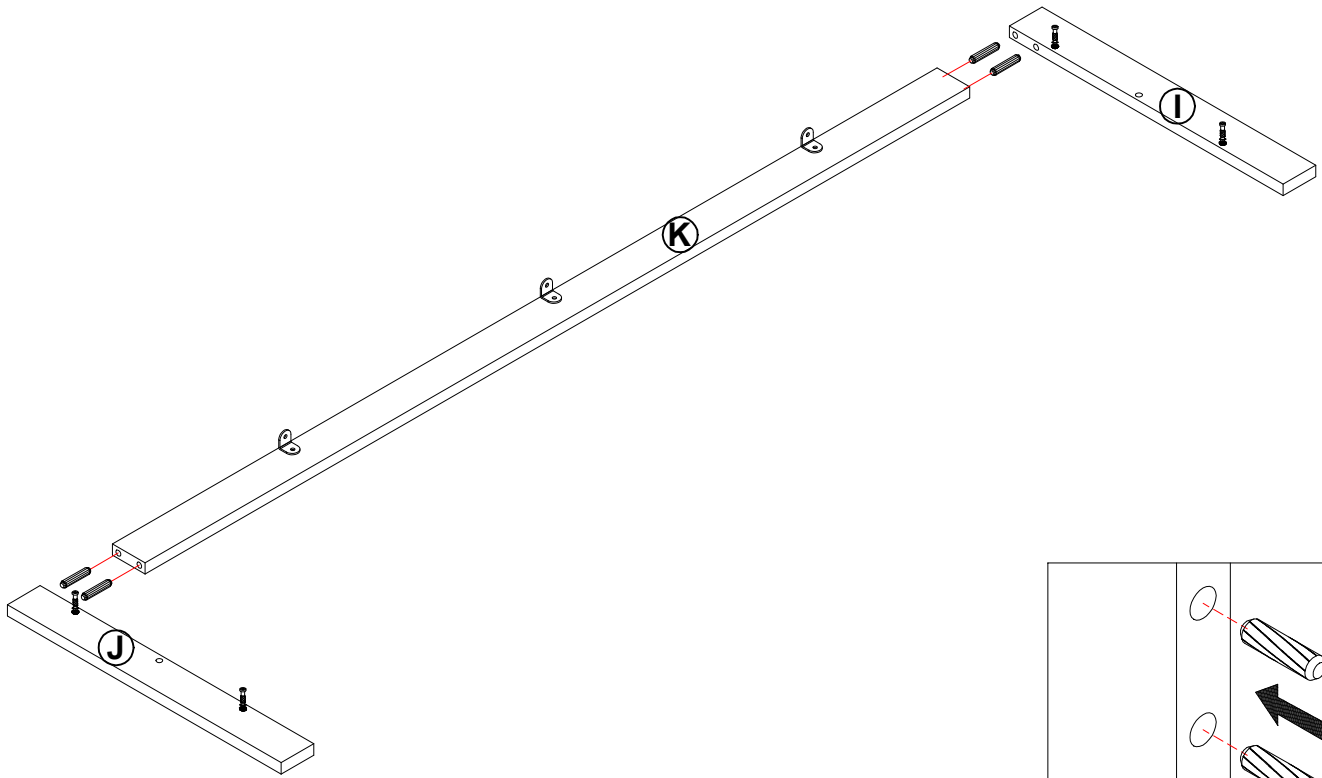
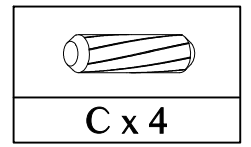

# Step 8

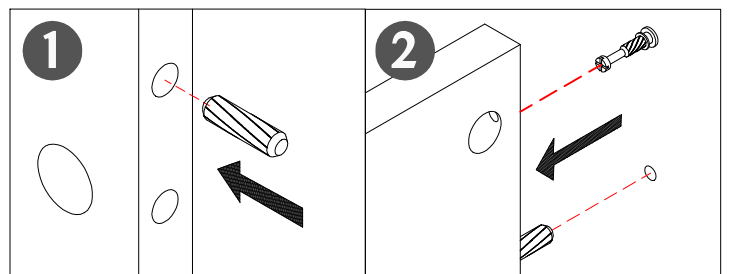
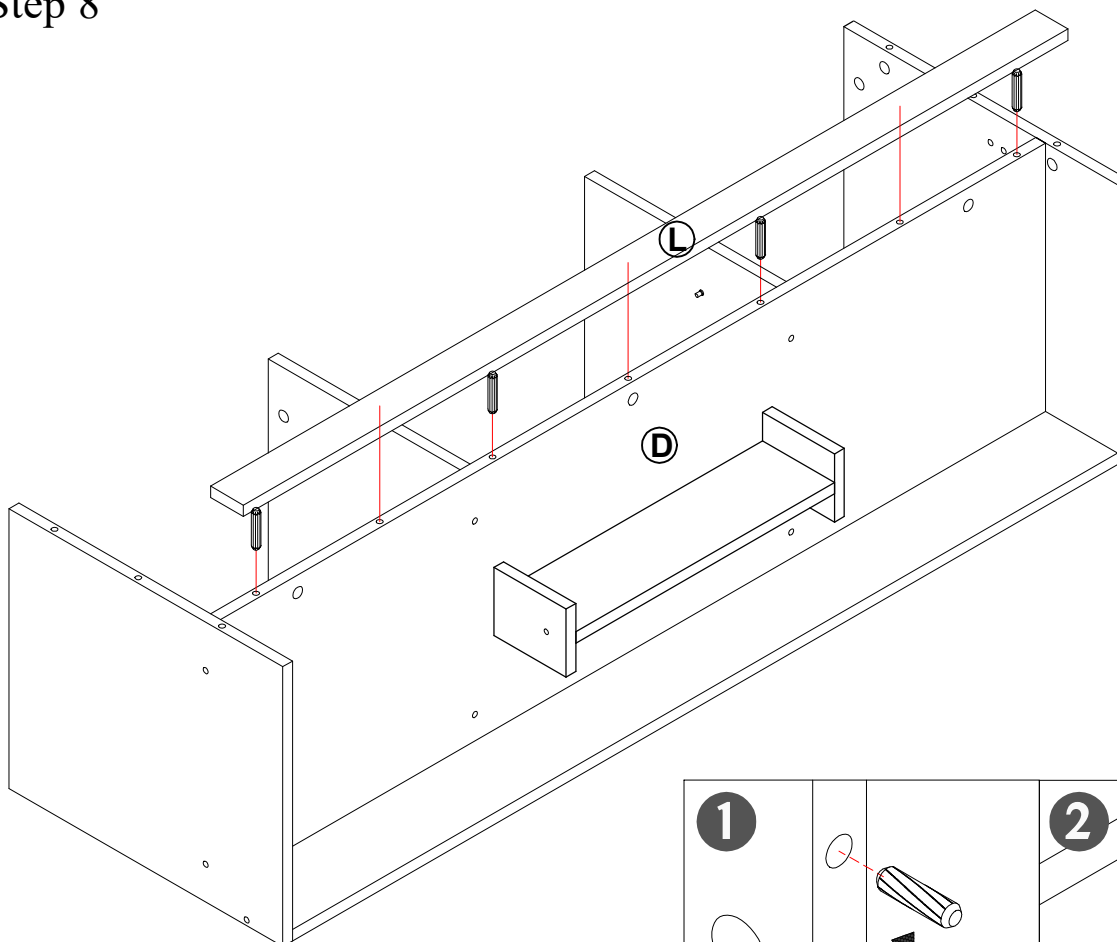
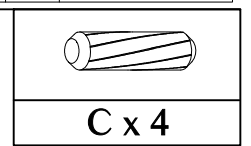

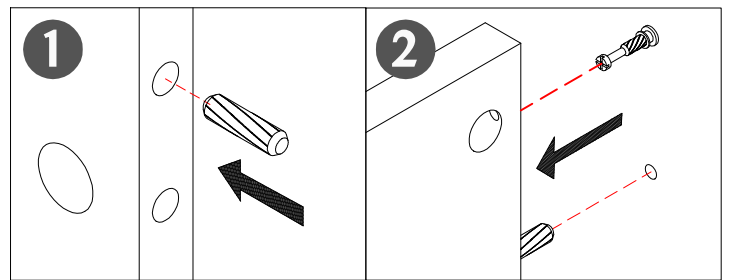
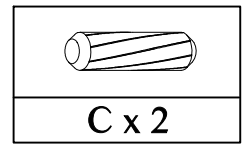
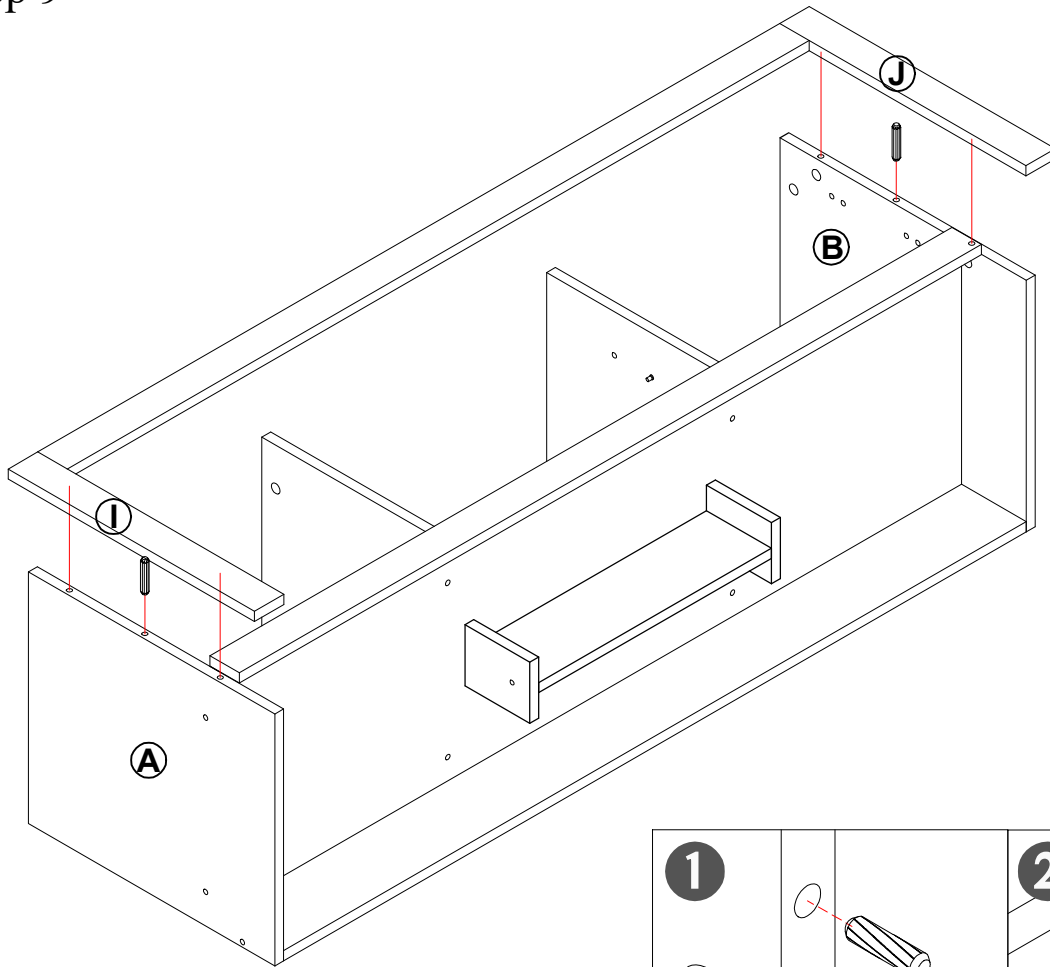

# Step 9

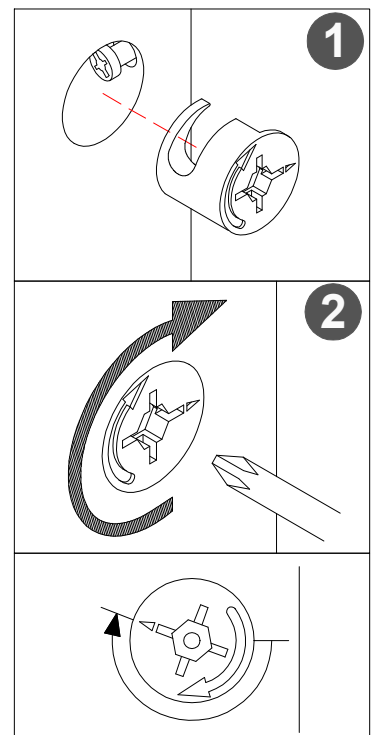
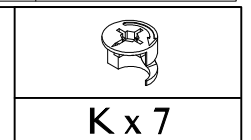
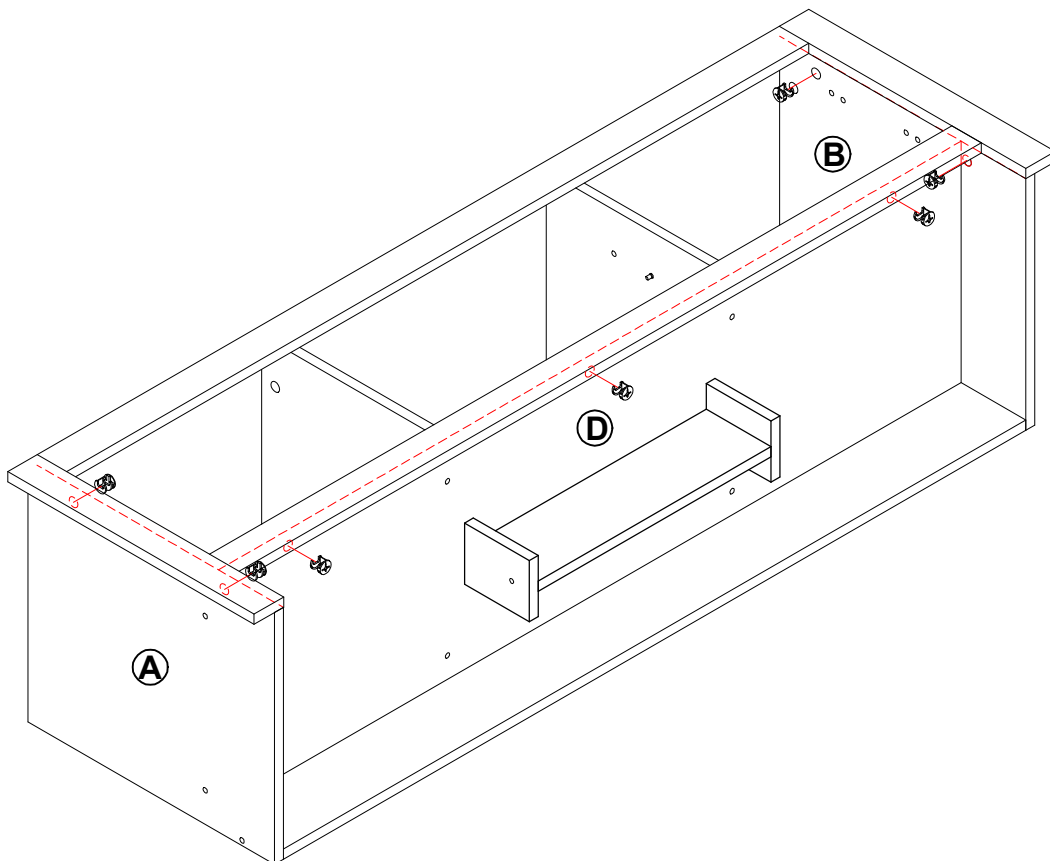

# Step 10



# Step 11

|                                                                                   |                                                                                     |                                                                                    |
|-----------------------------------------------------------------------------------|-------------------------------------------------------------------------------------|------------------------------------------------------------------------------------|
|  |  |  |
| <b>F x 4</b>                                                                      | <b>J x 8</b>                                                                        | <b>L x 2</b>                                                                       |

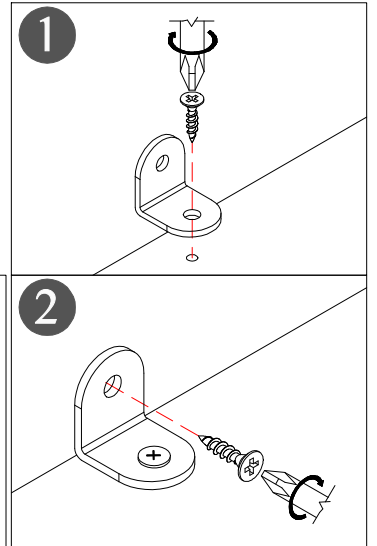
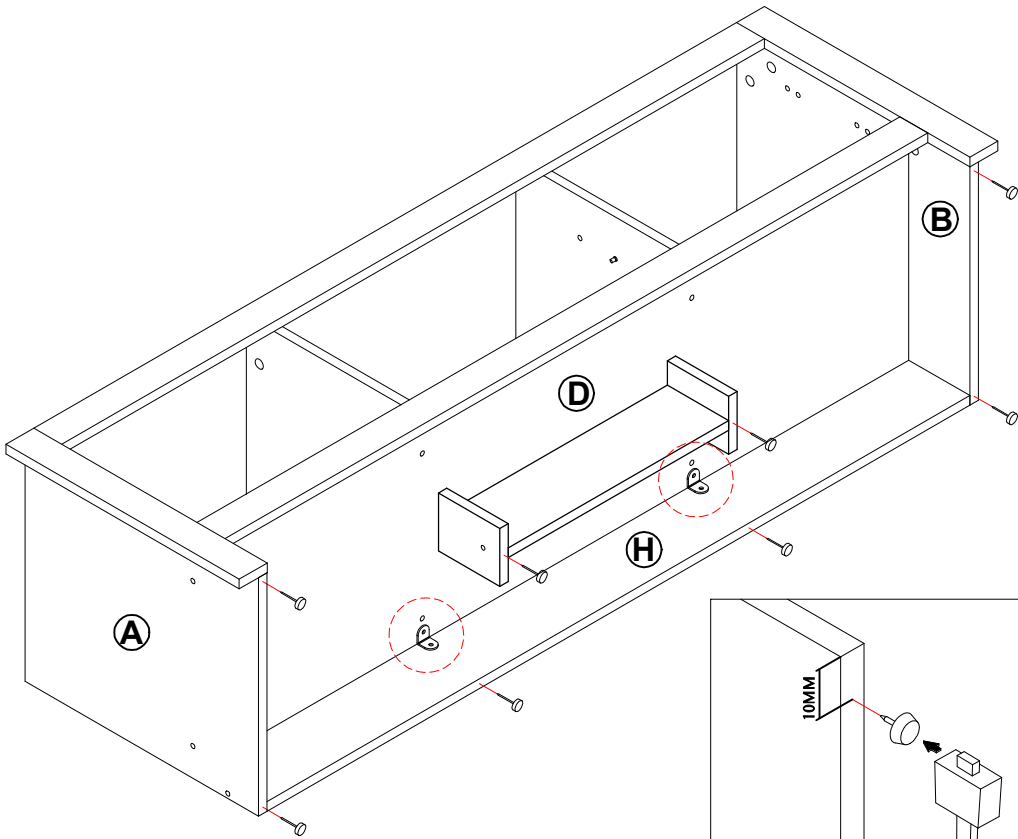

# Step 12

|                                                                                       |
|---------------------------------------------------------------------------------------|
|  |
| <b>B x 8</b>                                                                          |

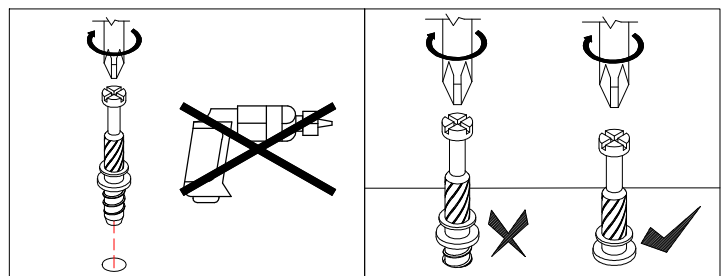
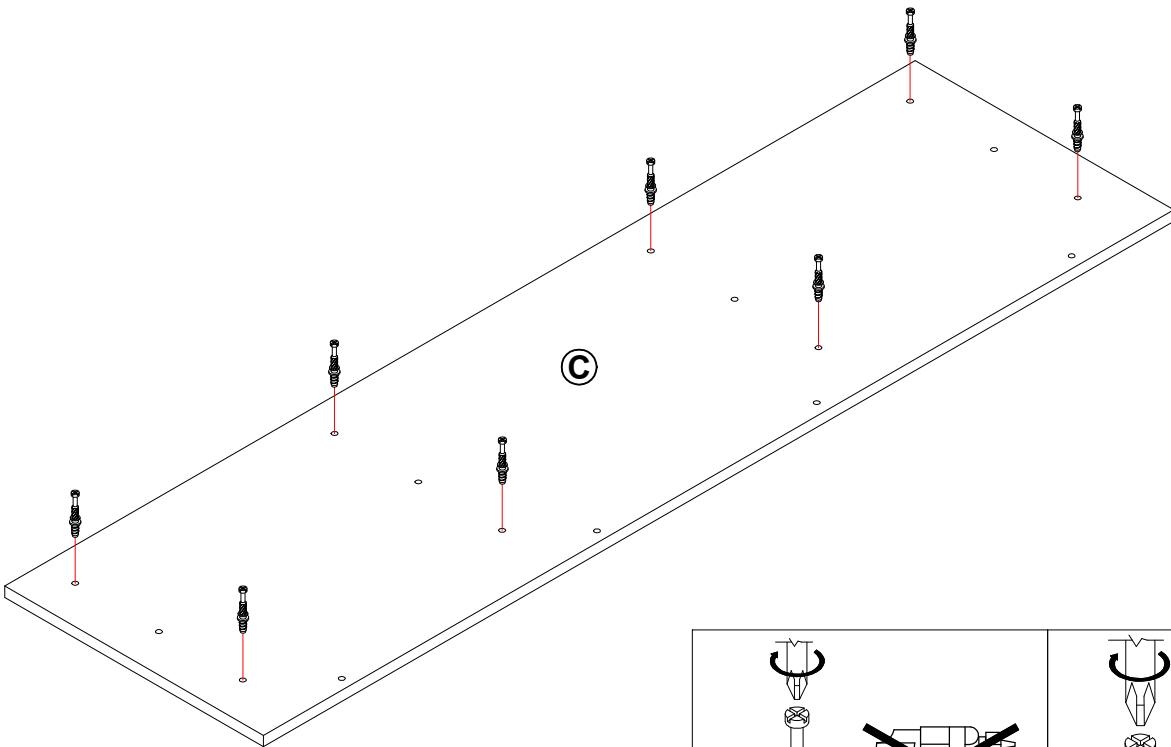

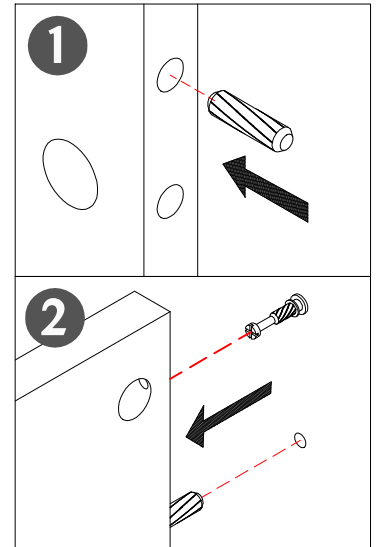
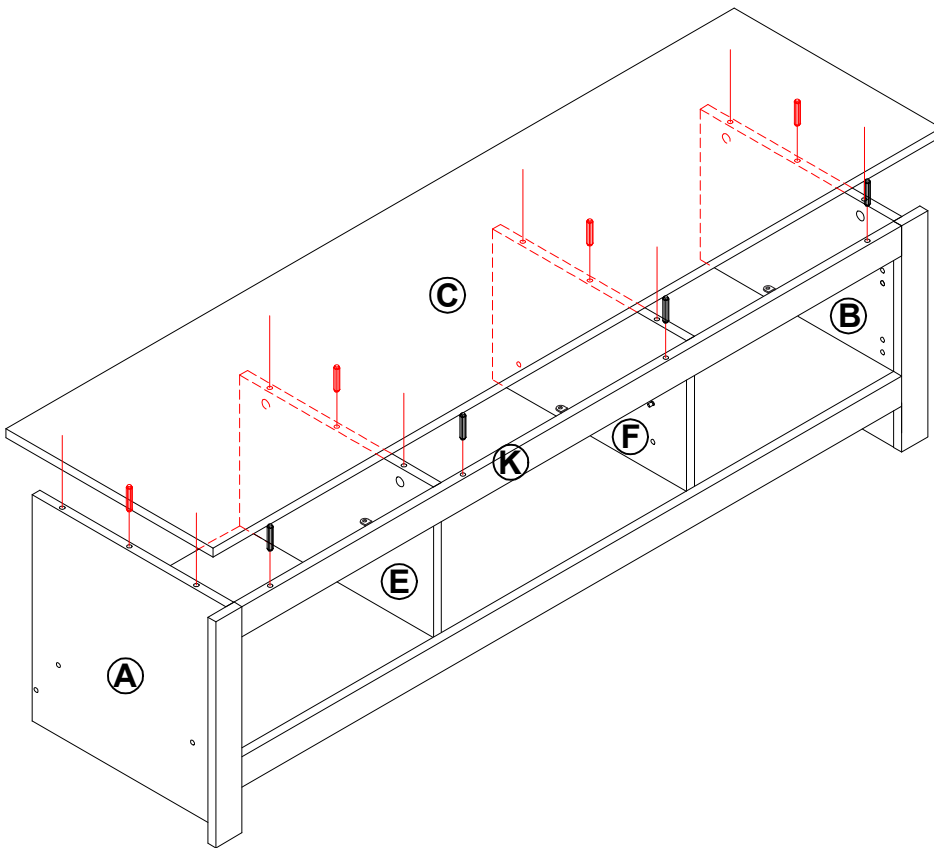
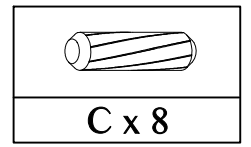

# Step 13

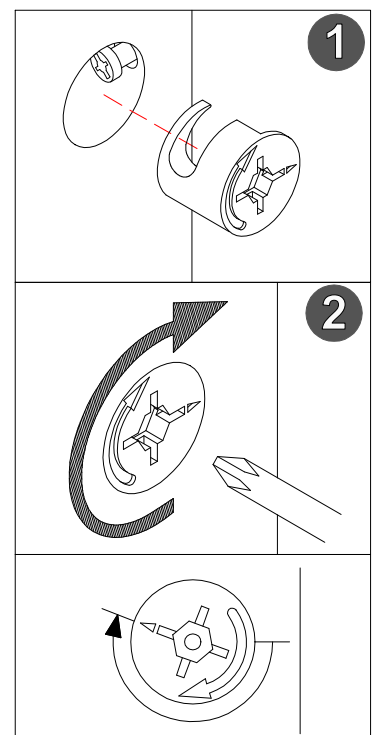
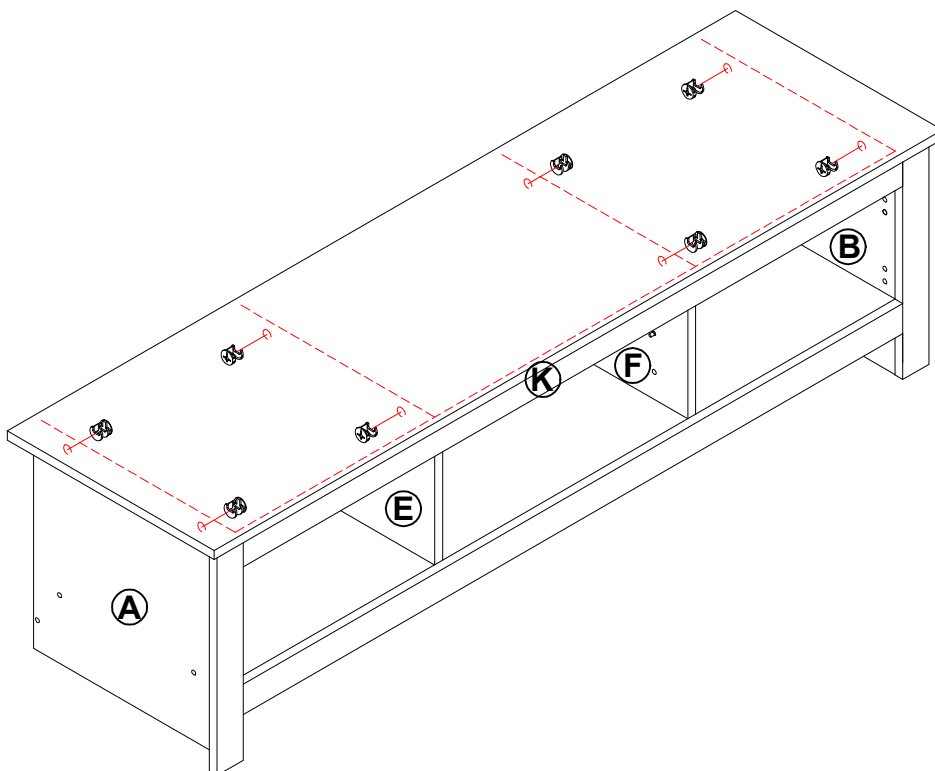
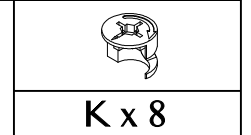

# Step 14



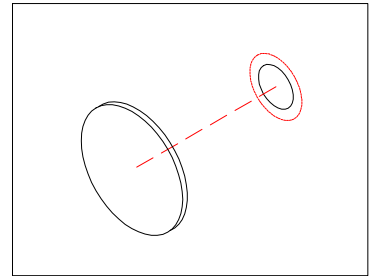
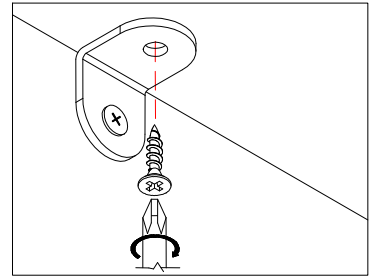
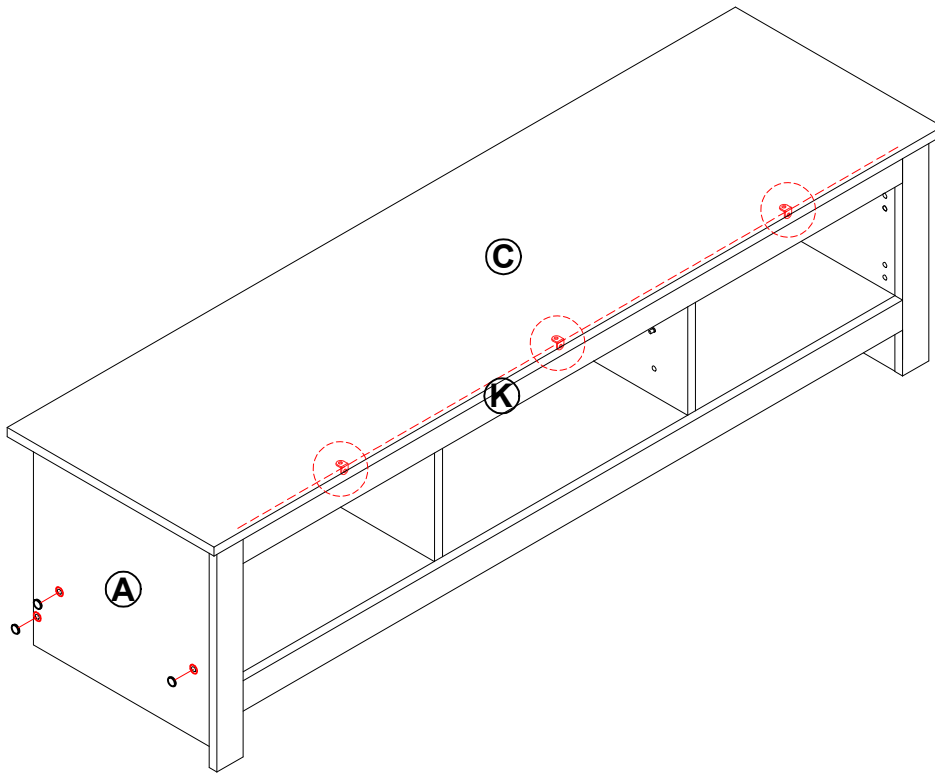

# Step 15

|                                                                                     |                                                                                    |
|-------------------------------------------------------------------------------------|------------------------------------------------------------------------------------|
|  |  |
| <b>F x 3</b>                                                                        | <b>O x 3</b>                                                                       |



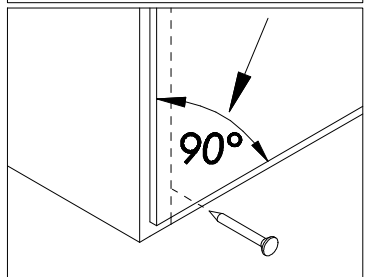
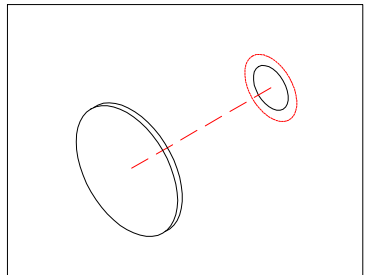
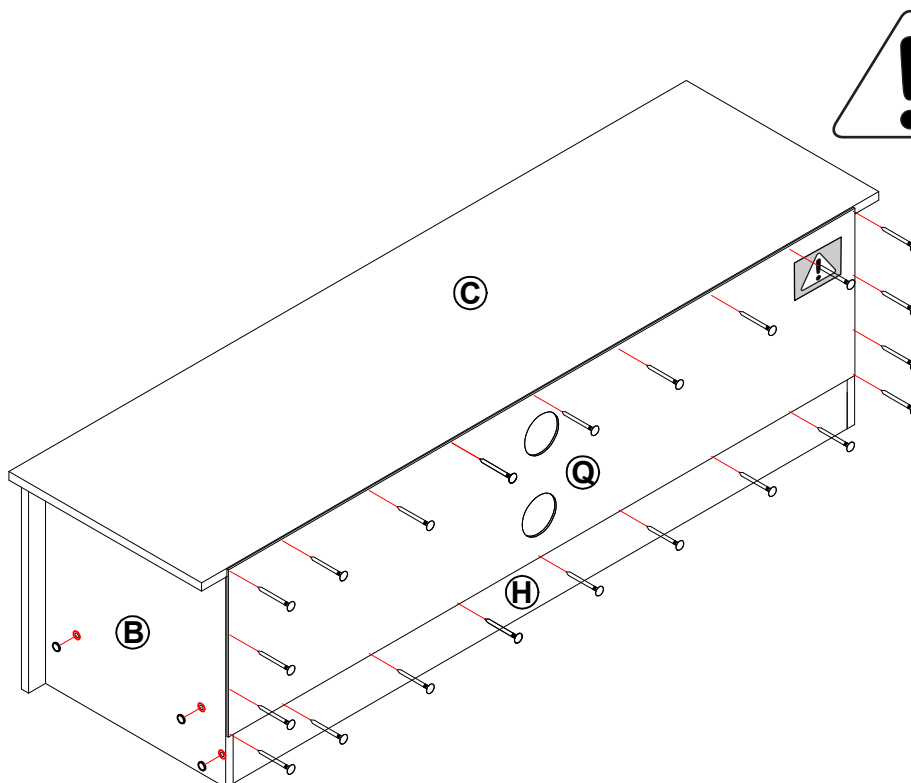

# Step 16

|                                                                                       |                                                                                       |
|---------------------------------------------------------------------------------------|---------------------------------------------------------------------------------------|
|  |  |
| <b>I x 22</b>                                                                         | <b>O x 3</b>                                                                          |



# Step 17

|                                                                                    |                                                                                     |
|------------------------------------------------------------------------------------|-------------------------------------------------------------------------------------|
|  |  |
| <b>P x 1</b>                                                                       | <b>E x 1</b>                                                                        |

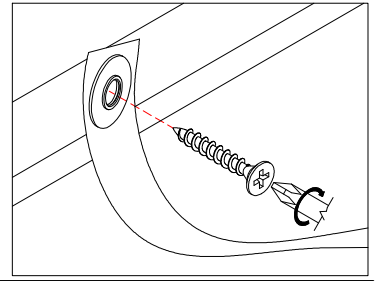
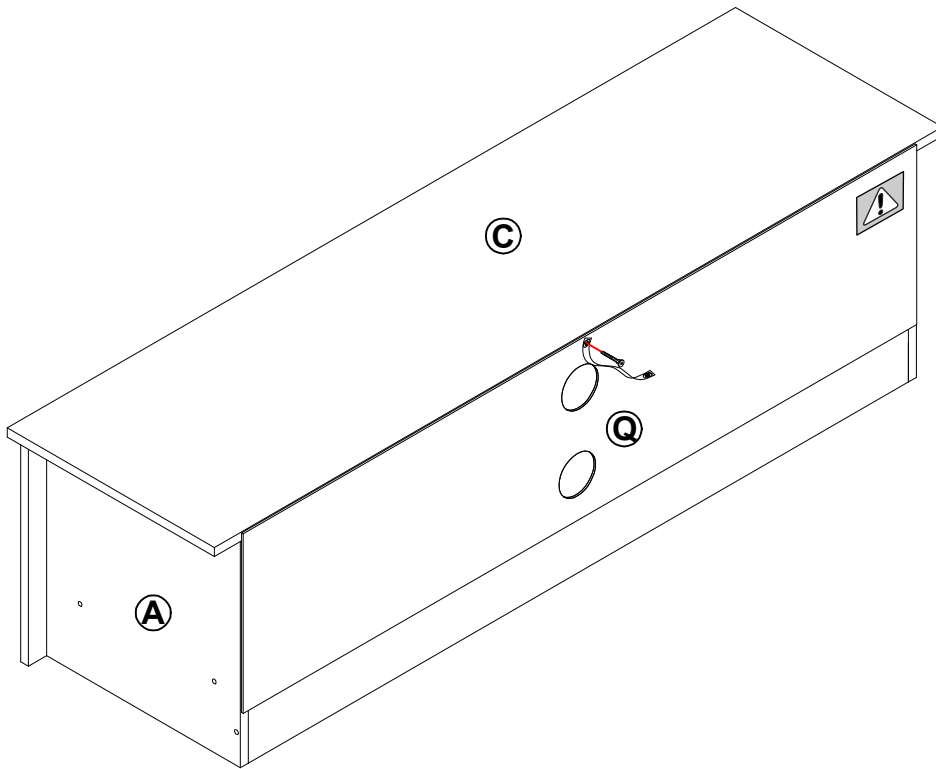

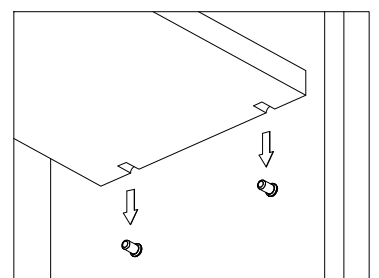
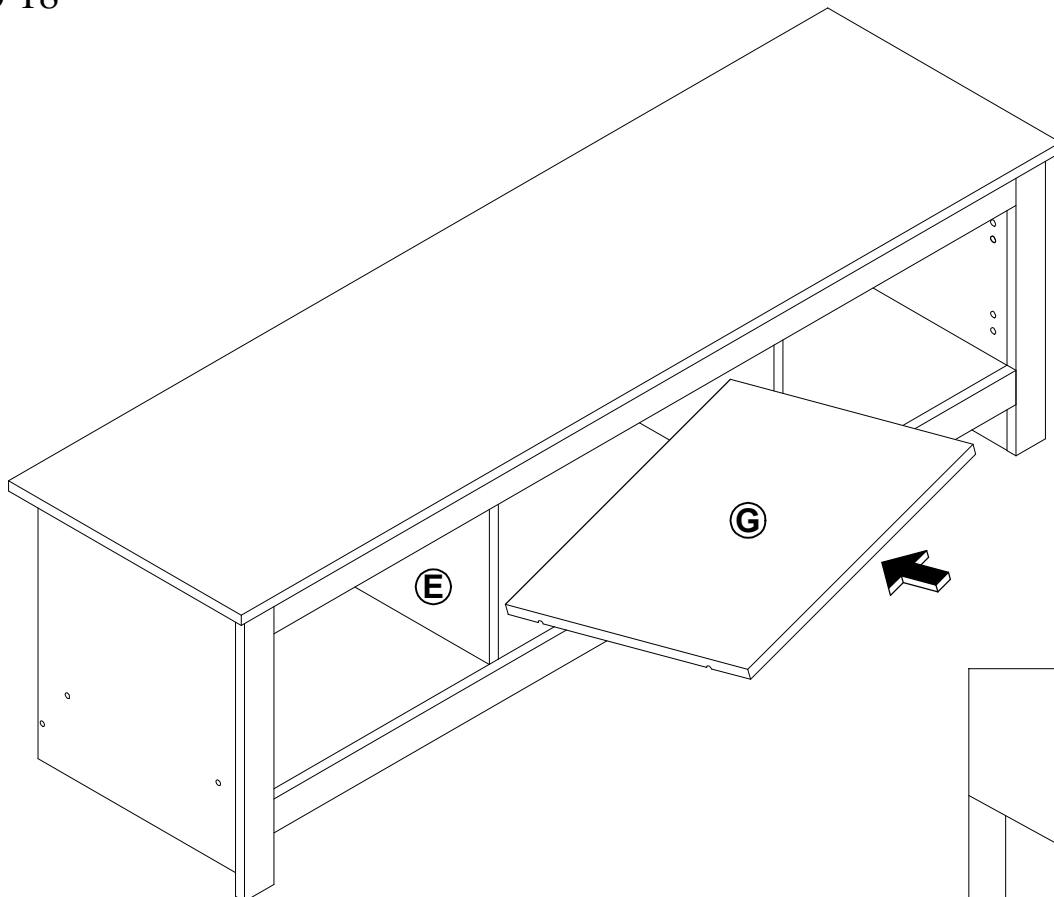

# Step 18

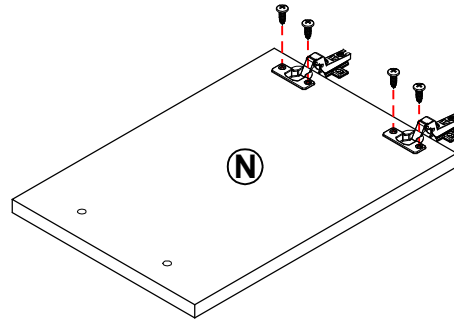
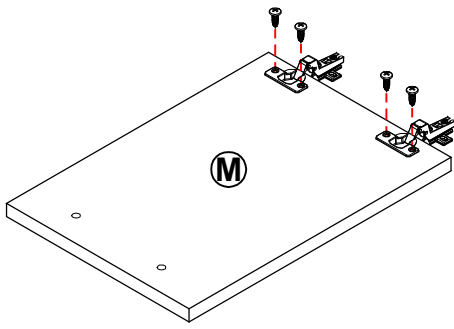

# Step 19



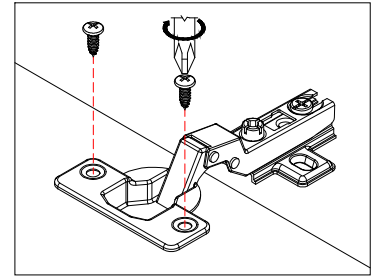

|                                                                                     |                                                                                    |
|-------------------------------------------------------------------------------------|------------------------------------------------------------------------------------|
|  |  |
| <b>G x 8</b>                                                                        | <b>N x 4</b>                                                                       |

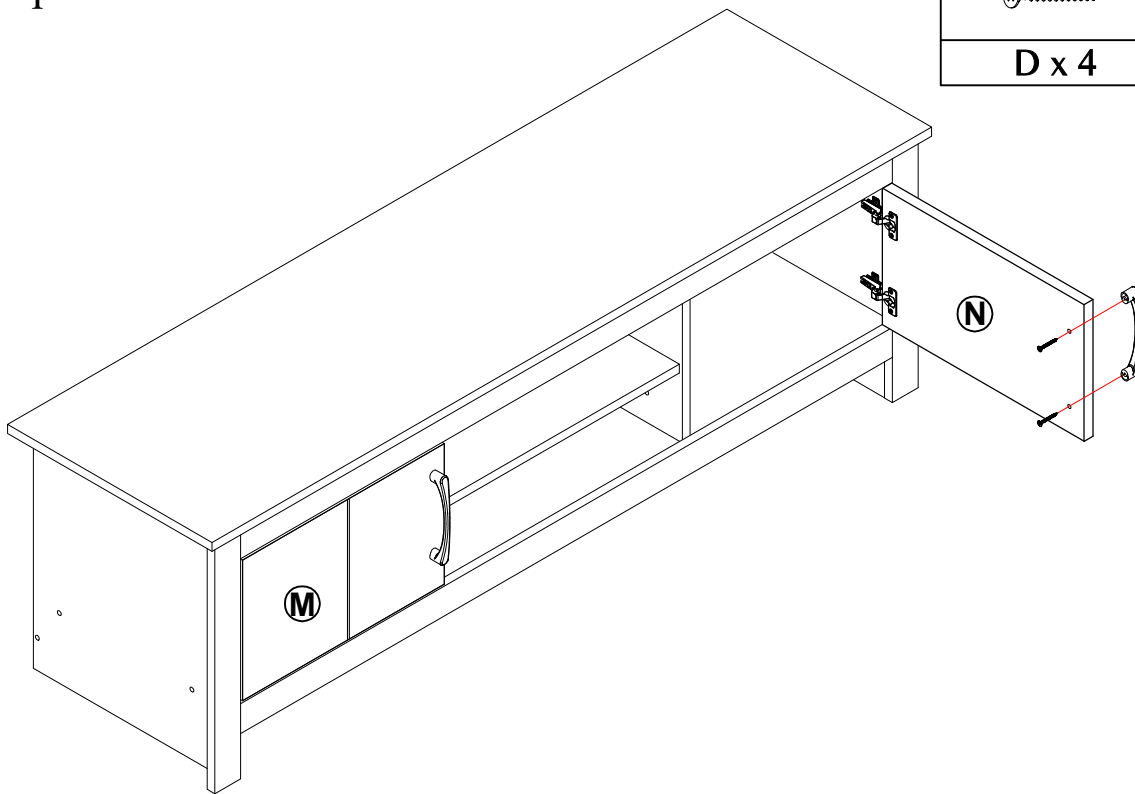

# Step 20

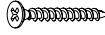

|                                                                                     |                                                                                     |
|-------------------------------------------------------------------------------------|-------------------------------------------------------------------------------------|
|  |  |
| <b>D x 4</b>                                                                        | <b>M x 2</b>                                                                        |
|  |                                                                                     |
| <b>G x 8</b>                                                                        |                                                                                     |

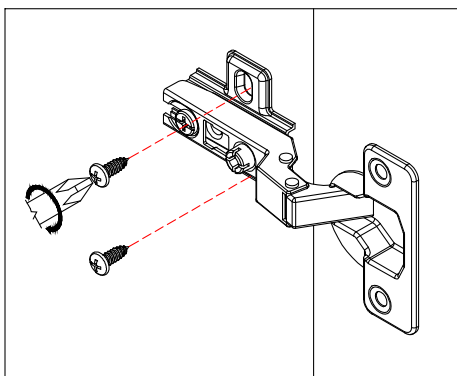
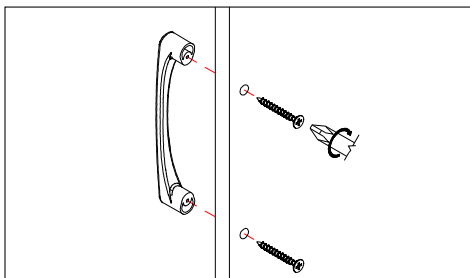

# SPECIAL TIPS FOR DOOR ALIGNMENT

## CONSEJOS ESPECIALES PARA LA ALINEACIÓN DE PUERTAS

### CONSEILS SPÉCIAUX POUR L'ALIGNEMENT DES PORTES

- A. Lateral adjustment (Moving door left-right) by screw adjusting  
 Ajuste lateral (Puerta móvil de izquierda a derecha) mediante tornillo de ajuste  
 Réglage latéral (porte mobile gauche-droite) par réglage à vis

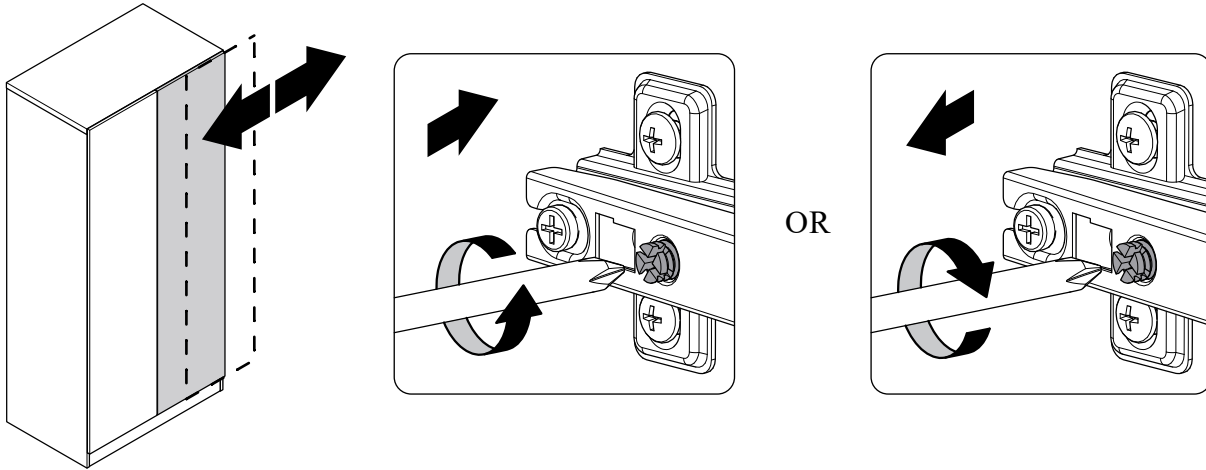

- B. Vertical adjustment (Moving door up-down) via the slot on the mounting plate  
 Ajuste vertical (Puerta móvil arriba-abajo) a través de la ranura en la placa de montaje  
 Réglage vertical (porte mobile de haut en bas) via la fente sur la plaque de montage

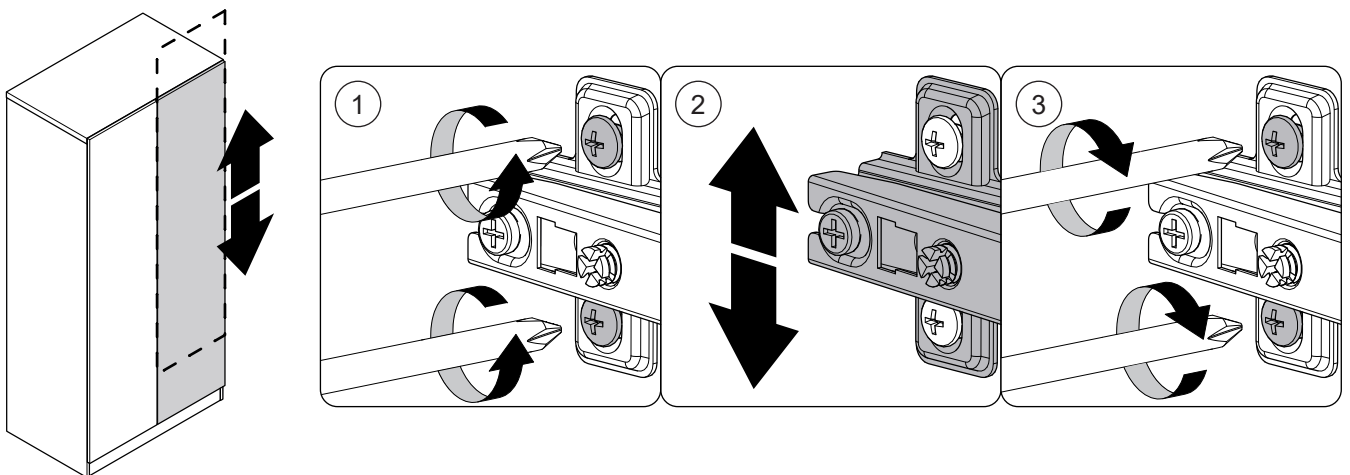

- C. Front-to-back adjustment (Spacing Door Off Cabinet) by slacking the hinge arm mounting screw  
 Ajuste de adelante hacia atrás (espaciado entre la puerta y el gabinete) aflojando el tornillo de montaje del brazo de la bisagra  
 Ajustement d'avant en arrière (espacement de la porte hors de l'armoire) en desserrant la vis de montage du bras de charnière

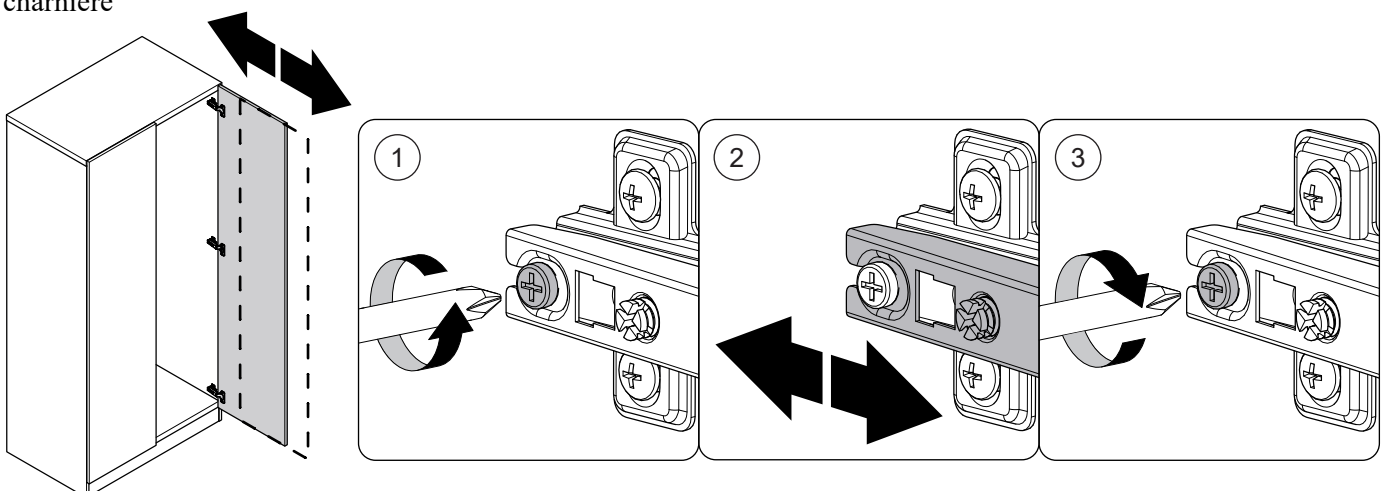

# FITTING OF ANTI-TOPPLE SAFETY STRAP

## MONTAGE DE LA SANGLE DE SÉCURITÉ

### ANTI-RENVERSEMENT

#### COLOCACIÓN CORREA DE SEGURIDAD ANTI-TOPPLE

#### STEP 1:

Fix screw through safety strap hole on the top panel of your furniture.

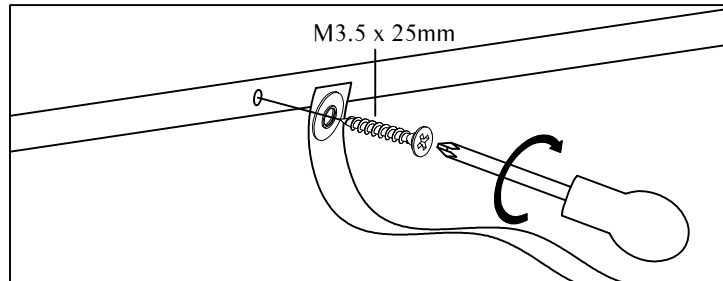

#### STEP 2:

Drill a hole on the wall and insert the wall plug.

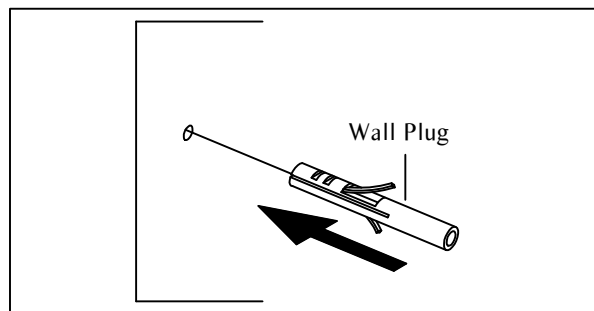

#### STEP 3:

Fix screw through the safety strap in the wall plug hole.

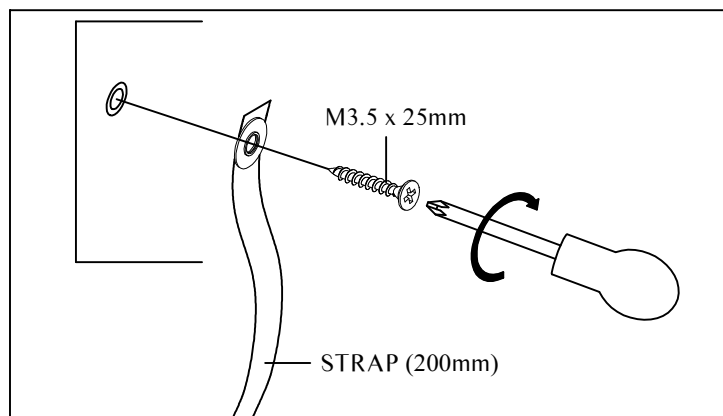

**NOTE:** Wall fixings are not supplied with this product as different wall materials require different types of fixing devices (such as Rawl plugs on bricks wall). You must use fixing devices suitable for the type of wall you intend to mount this product to. Please ensure that the head of any screw used has a diameter greater than the diameter of the mounting hole on the product and that the fixing is safe and secure before use.

The straps and screws which to fix the strap on to the furniture are provided only.

## HARDWARE LIST



STRAP (200mm) - 1 Pc



M3.5 x 25mm - 1 Pc

## MAXIMUM LOADS CHARGES MAXIMALES / CARGA MAXIMA

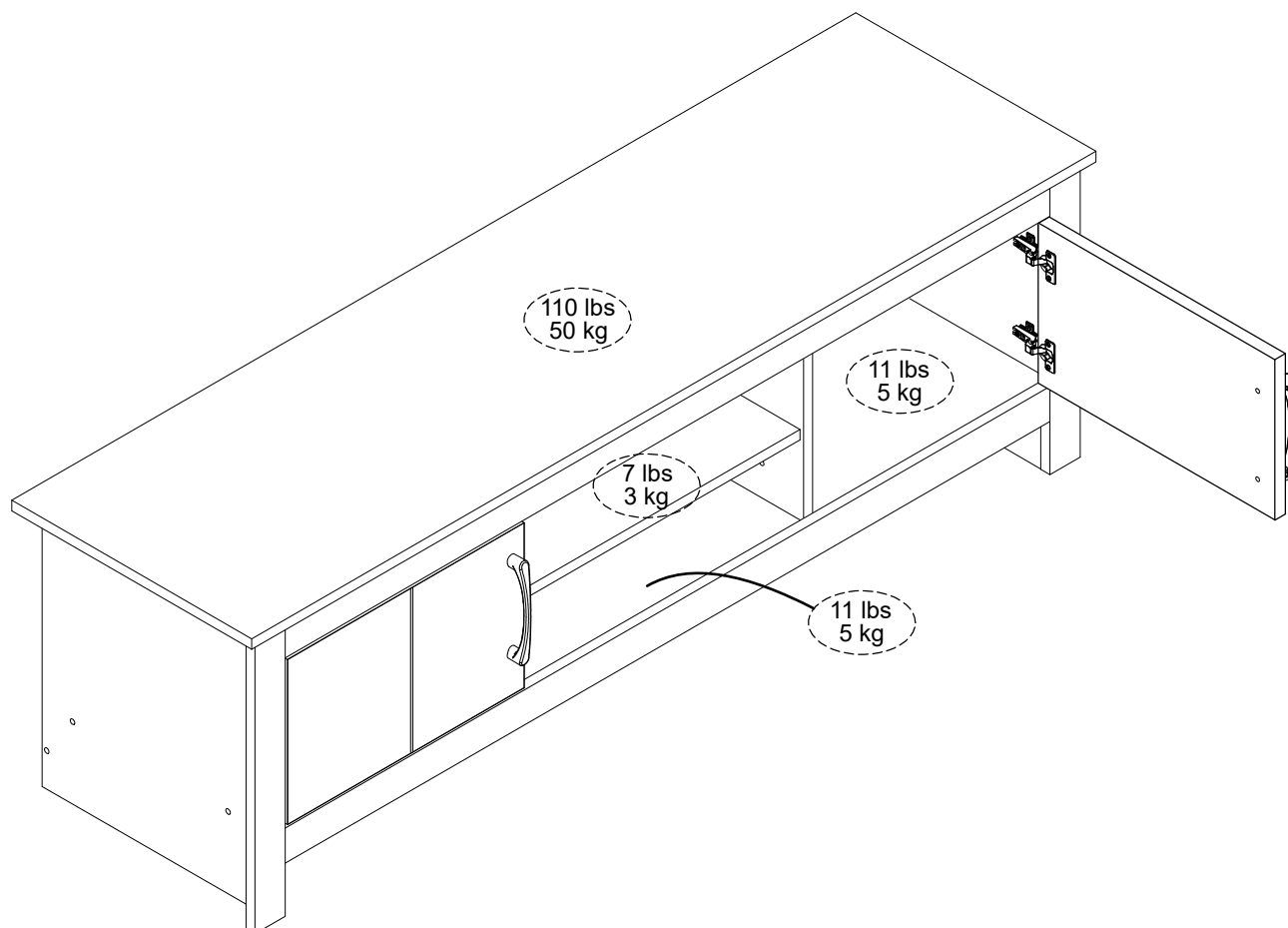

---

This product is designed to withstand the weight noted on the plan. We are not responsible for the breakage of parts or any injury caused by failure to comply with this recommendation.

---

Ce produit est conçu pour supporter le poids indiqué sur le plan. Nous ne sommes pas responsables de la casse de pièces ou toute blessure causée par le non-respect de cette recommandation.

---

Este producto está diseñado para soportar el peso indicado en el plano. No somos responsables de la rotura de piezas o cualquier lesión causada por el incumplimiento de esta recomendación.

---