













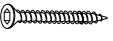





ASSEMBLY INSTRUCTIONS

Before you begin, please follow assembly instructions carefully, then follow them step by step.

Read instruction carefully . See Furniture Parts list and Hardware List for guidance . Be sure you have all parts before you start assembling . Place and assemble furniture on a clean flat soft surface , such as carpet or rug to prevent being scratched .

PART LIST		QTY
1	TOP PANEL	1 PC
2	BOTTOM PANEL	1 PC
3	SIDE PANEL (L)	1 PC
4	SIDE PANEL (R)	1 PC
5	CENTER PANEL	1 PC
6	BACK PANEL	1 PC
7	SHELF PANEL (L)	4 PCS
8	SHELF PANEL (R)	4 PCS
9	DOOR PANEL (L)	1 PC
10	DOOR PANEL (R)	2 PCS

HARDWARE			
A	MINI FIX A1  A2  A3 	6 SETS	
B	M8 X 30MM WOOD DOWEL 	12 PCS	
C	M6 X 50MM CSK CAP WOOD SCREW 	6 PCS	
D	M4 X 25MM C.B SCREW 	6 PCS	
E	M3.5 X 16MM C.B SCREW 	40 PCS	
F	ALLEN KEY M4 	1 PC	
G	5/8 NAIL 	35 PCS	
H	5/8 HINGES 	6 PCS	
I	METAL SHELF SUPPORT 	32 PCS	
J	PVC HANDLE 108-160 	3 PCS	
K	PVC SQUARE LEG 5038 	4 PCS	
L	TIPPING PACK  L1  L3  L2  L4  L5 	2 SETS	

SELF-PREPARED TOOLS: Tools below are NOT included in package.



SCREWDRIVER



HAMMER



POWER DRILL

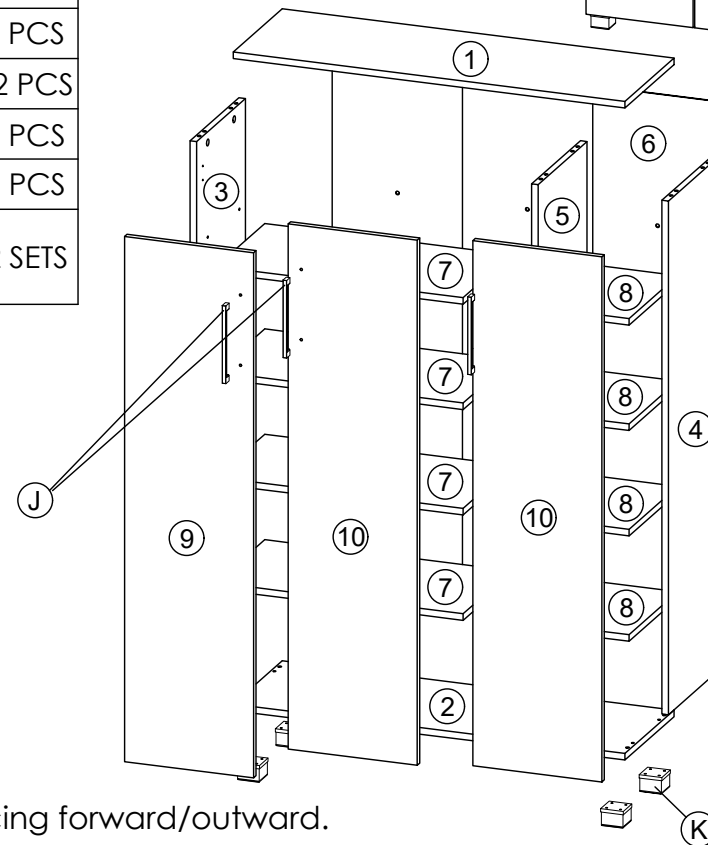
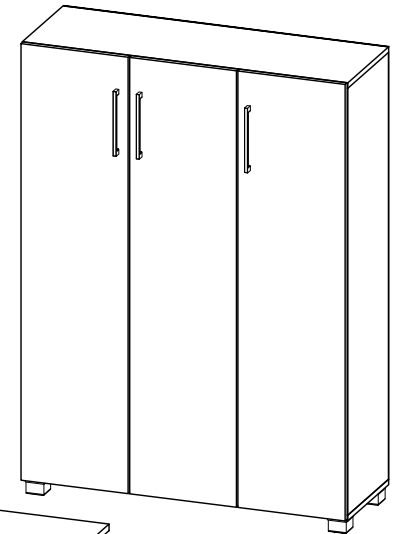

Reminder:

Please ensure that all surfaces and edges with colours/laminations are facing forward/outward.

ASSEMBLY INSTRUCTIONS

STEP 1

- Insert hardware **A1** onto panel (3), (4) and (5).
(Repeat 6 times.)
- Insert hardware **A2** onto panel (1).
(Repeat 4 times.)
- Insert hardware **B** onto panel (3), (4) and (5).
(Repeat 12 times.)

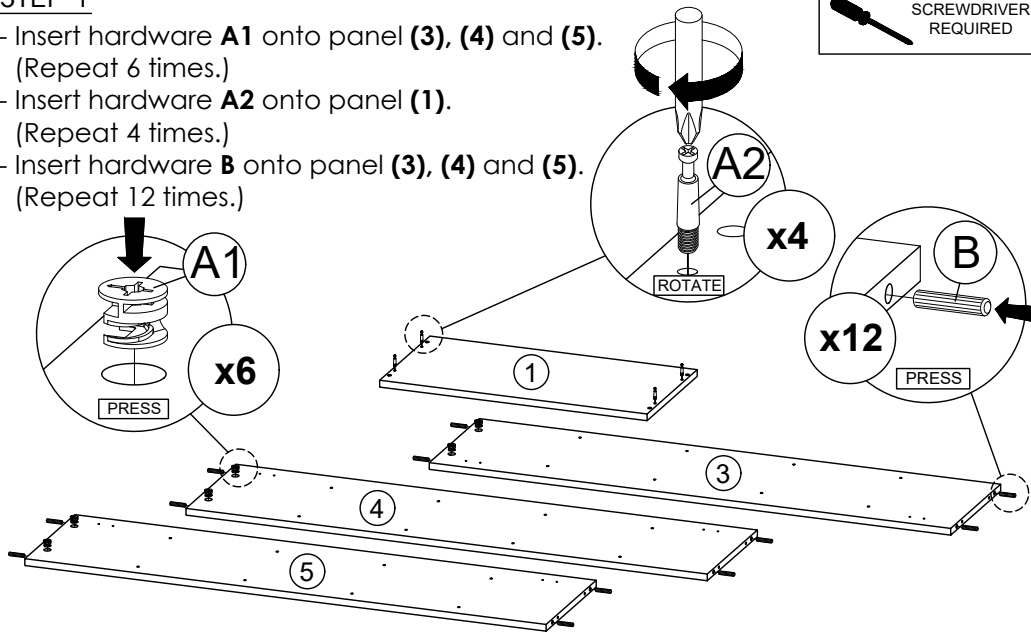

* Ensure the arrows on hardware **A1** point towards mounting positions.

STEP 2

- Attach panel (3), (4) and (5) to panel (1).
- Insert all hardware **A2** into **A1**.
- Rotate all **A1** until tight.
- Apply **A3** onto all **A1**.
(Repeat 6 times.)

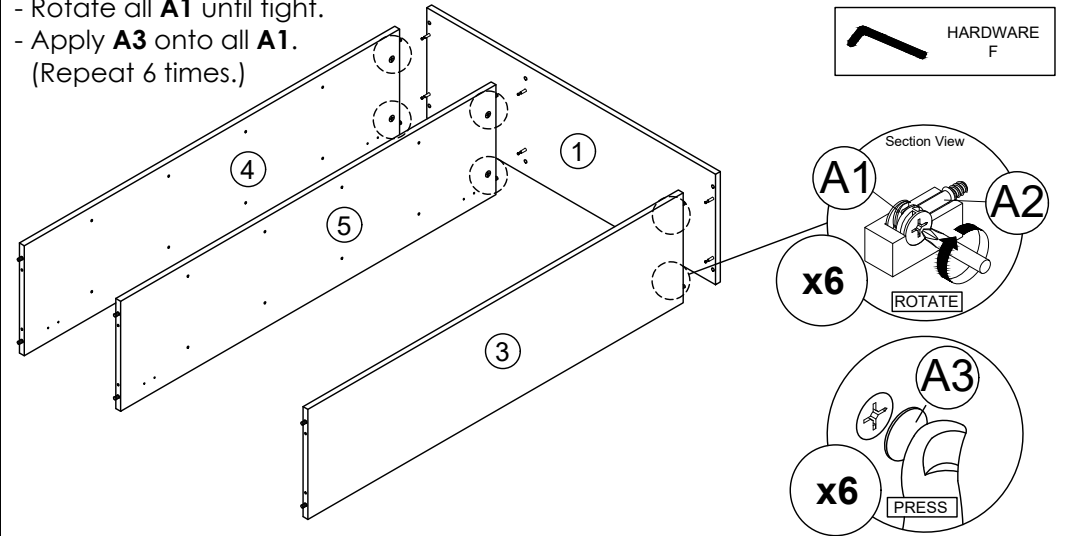

OR



* In this step hardware **A1**, **A2** and **B** are pre-inserted.

STEP 3

- Connect panel (2) to panel (3), (4) and (5) by using hardware **C** and **F**.
(Repeat 6 times.)

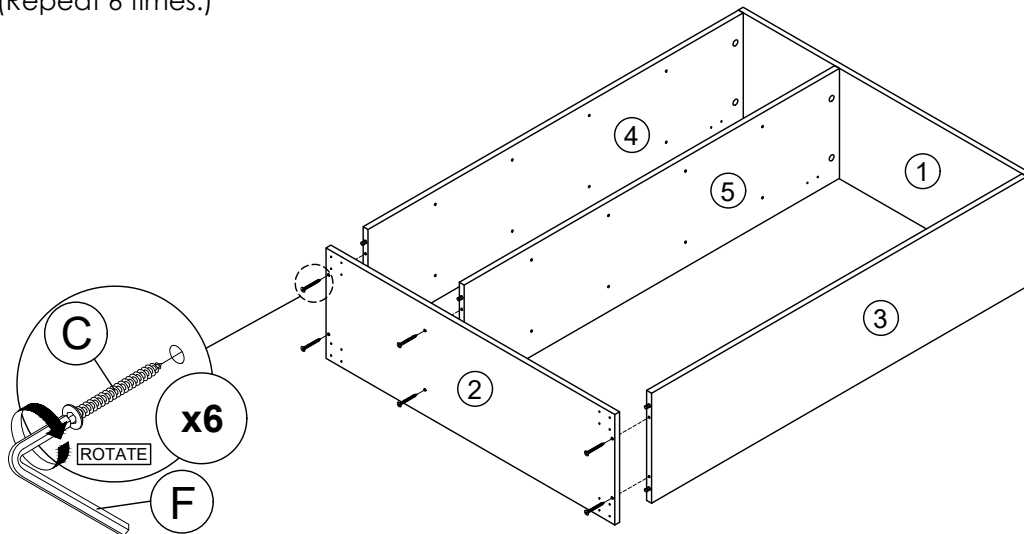

* In this step hardware **B** are pre-inserted.

STEP 4

- Fix hardware **K** into panel (2) with hardware **E**.
(Repeat 4 times for each hardware.)
- Cover back the hardware **K**.
(Repeat 4 Times)

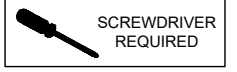
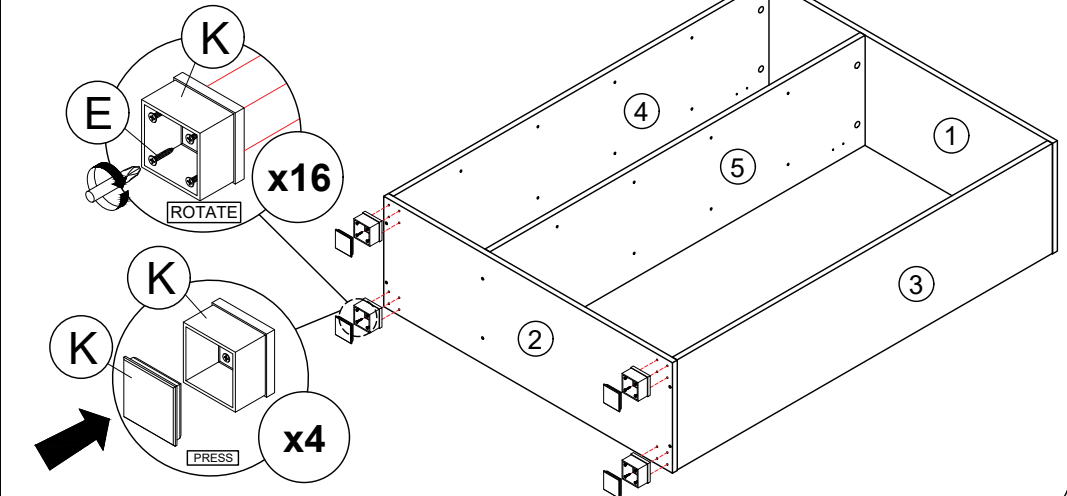

ASSEMBLY INSTRUCTIONS

STEP 5

Assemble panel **(6)** to entire body with hardware **G**.
(Repeat 35 times.)

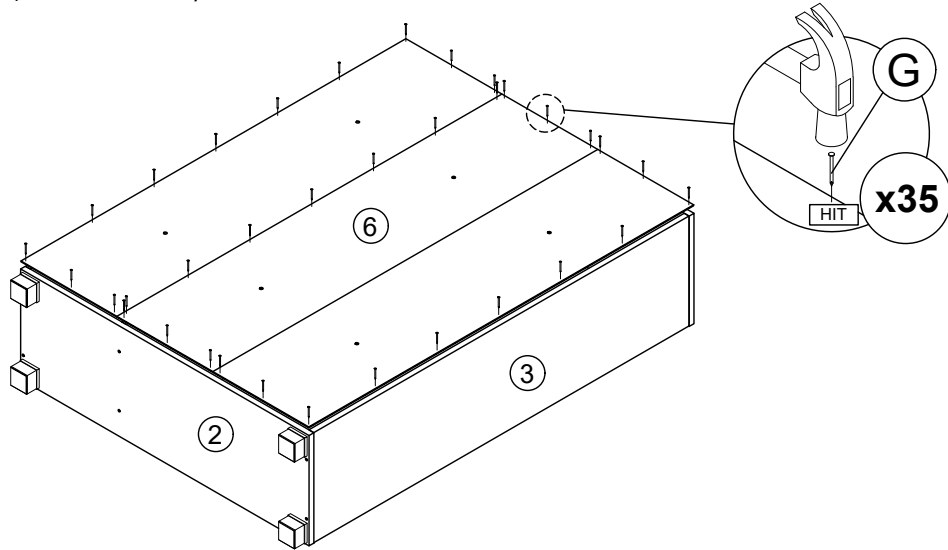

STEP 6

- Insert hardware **I** into mounting positions on panel **(3)**, **(4)** and **(5)** by hand.
(Repeat 32 times.)
- Assemble the panel **(7)** and **(8)** into between panel **(3)**, **(4)** and **(5)**.
(Repeat 8 times.)

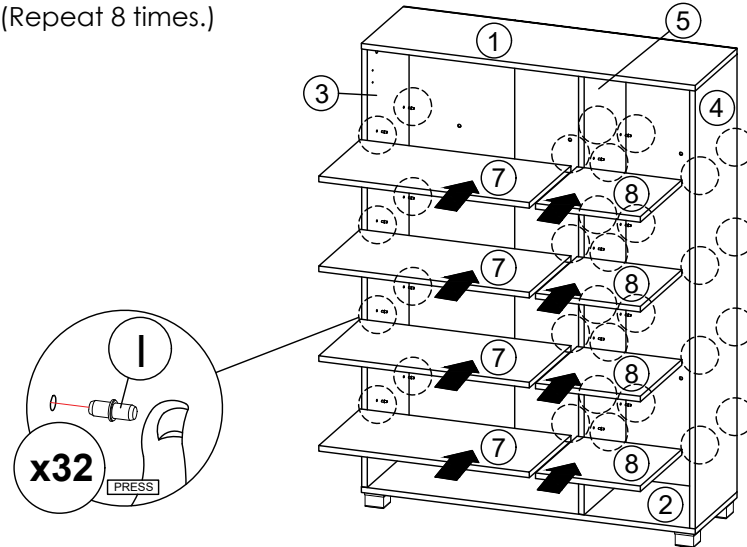

STEP 7

- Fix hardware **H** onto panel **(9)** and **(10)** by using hardware **E**.
(Repeat 2 times for each hardware.)
- Fix hardware **J** onto panel **(9)** and **(10)** by using hardware **D**.
(Repeat 2 times for each hardware.)

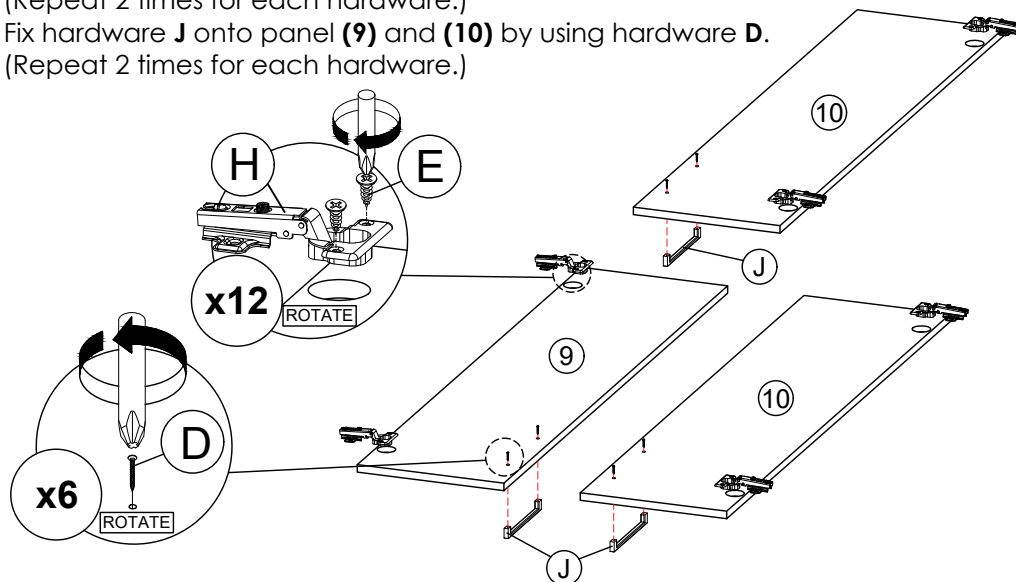

STEP 8

- Fix hardware **H** into panel **(3)**, **(4)** and **(5)** by using hardware **E**.
(Repeat 2 times for each hardware.)
- Tighten or loosen the screw to adjust position of panel **(9)** and **(10)**.
(Do only when needed.)

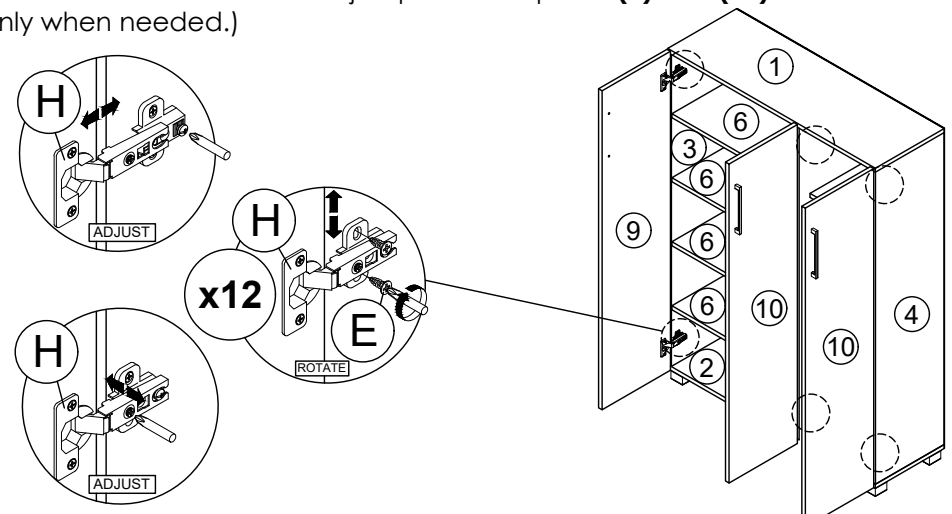
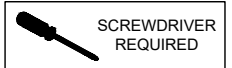

* In this step hardware **H** have been assembled in panel **(9)** and **(10)**.

ASSEMBLY INSTRUCTIONS

STEP 9

Assemble hardware **L1** into panel **(1)** and **(6)** by using hardware **L2**.
(Repeat 2 times.)

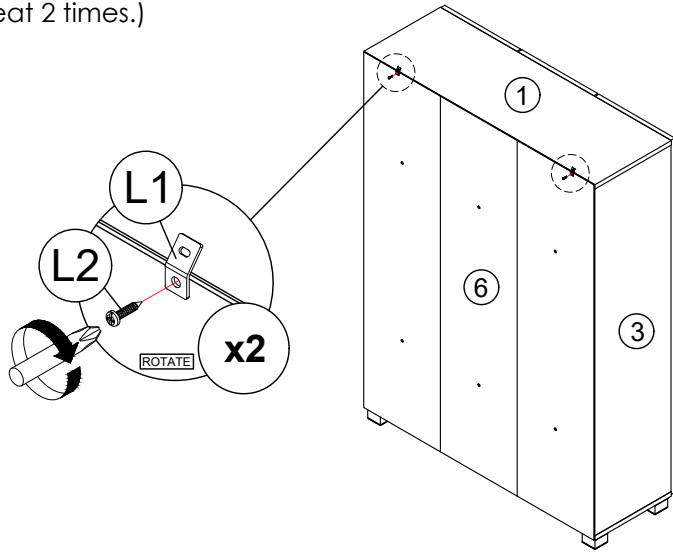

STEP 10

- Mark and use the power drill to drill a hole on the wall.
- Hit hardware **L3** into the wall.
(Repeat 2 times.)

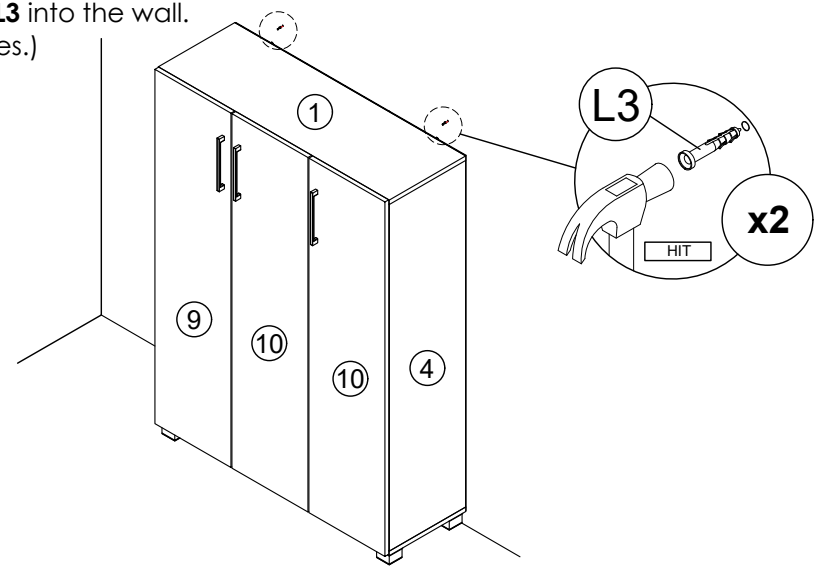

STEP 11

- Assemble hardware **L1** to **L3** by using hardware **L4**.
(Repeat 2 times.)

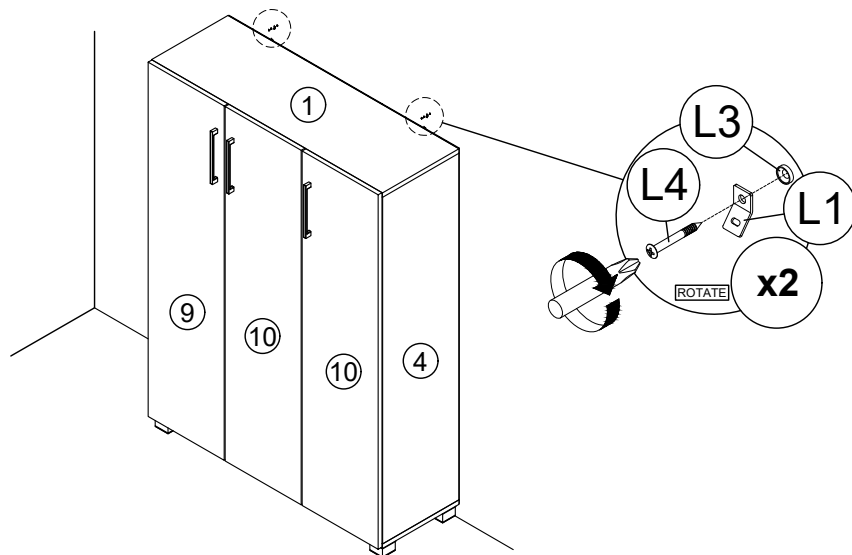

STEP 12

- Connect two of the hardware **L1** by using hardware **L5**.
- Tighten the hardware **L5**.
(Repeat 2 times.)

