

NOTES:

1. TO INSPECT ASSEMBLY, FOLLOW FIRST ARTICLE AND IN PROCESS INSPECTION SHEET.

2. APPLY LOCTITE 242.

BILL OF MATERIAL (CURRENT LEVEL)

ITEM	PT/ASSY	DESCRIPTION	TYPE	QTY.
1	2-239	SINGLE HOLE CROSS BAR ASSEMBLY	ASSEMBLY	1
2	2-132	BAR SPOUT ASM	ASSEMBLY	1
3	12593	NUT - DOME HEX	PART	2
4	12062	ADAPTER - 20-T X 16-T	PART	2
5	92539	SCRW, M4X22 FLAT HD SOCKET HD CAP	PART	2
6	2-279	TAPERED LEVER HNDL ASM	ASSEMBLY	2

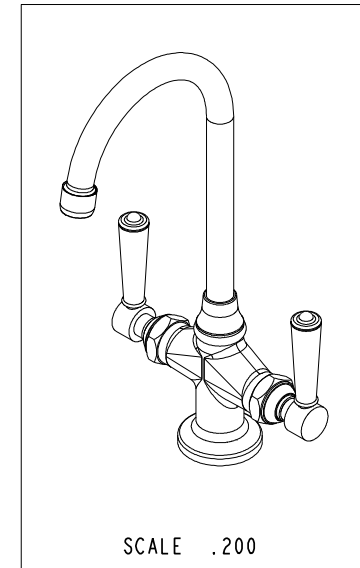
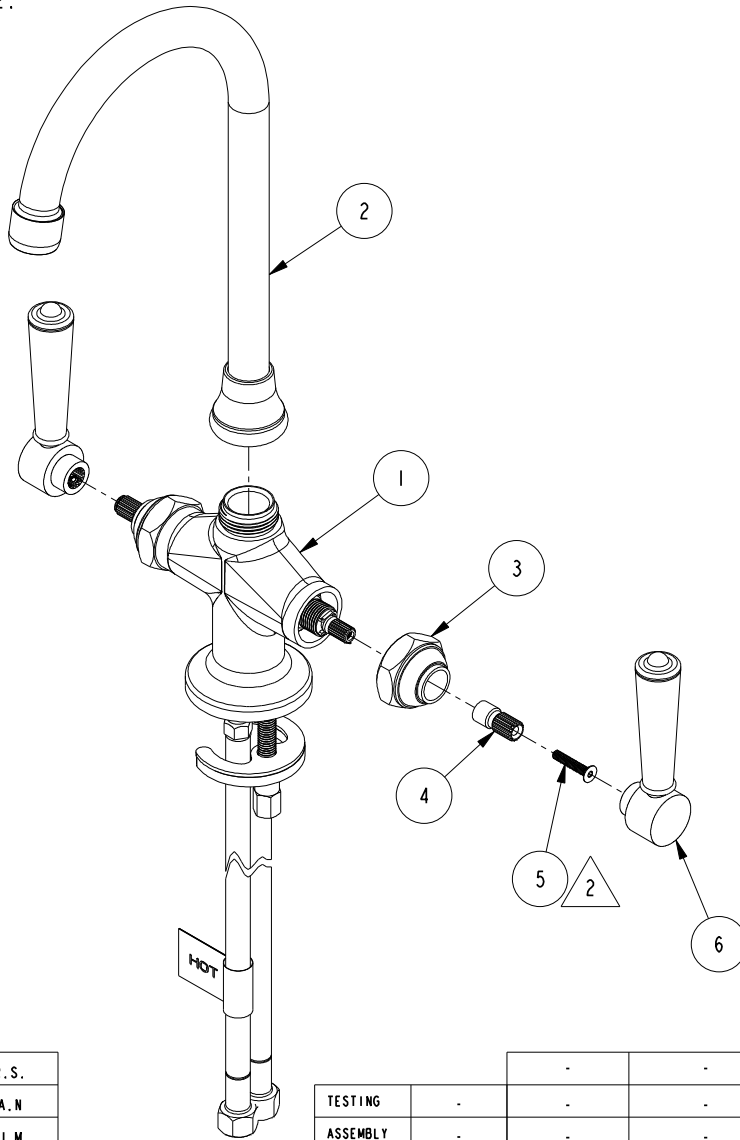

-	E	EN-4300hh	04/12/21	R.S.
-	D	EN-3173b	07/14/17	A.N
-	C	EN-2643	01/15/16	J.M
-	B	EN-2119	07/23/12	-
-	A	EO-0274	10/20/03	-
-	-	RELEASE	12/05/01	-
ZONE	REV	DESCRIPTION	DATE	APPROVED

COPYRIGHT 2005 BRASSTECH, INC. THESE DRAWINGS AND THE DESIGNS DEPICTED HEREIN ARE THE PROPRIETARY PROPERTY OF BRASSTECH. ANY USE OR REPRODUCTION IS SUBJECT TO THE EXPRESS APPROVAL OF BRASSTECH. UNAUTHORIZED USE IS STRICTLY PROHIBITED. ALL RIGHTS RESERVED.

TESTING	-	-	-
ASSEMBLY	-	-	-
PLATING	-	-	-
POLISHING	-	NEXT ASSY	USED ON
MACHINING	-	APPLICATION	
TOOLING FIXTURE #	REMOVE ALL BURRS AND SHARP EDGES		

UNITS ARE: INCHES [MM]		
TOLERANCES ARE:		
FRACTIONS	DECIMALS	ANGLES
±1/16"	.X ±.1 [2.5]	±1°
	.XX ±.06 [1.5]	
(X.XXX) DENOTES CRITICAL DIMS.		
ALL THREADS ARE CRITICAL		
DRAWN	VINAY	06/30/17
CHECKED	RAVINDRA	06/30/17
APPROVED	A.N	06/30/17

BRASSTECH		2001 CARNEGIE AVE. SANTA ANA, CA 92705 (949) 417-5207	
INCORPORATED			
BAR FAUCET			
DWG NO.		REV	
1208		E	
SCALE	REF.	SHEET	OF
.300	-	1	2

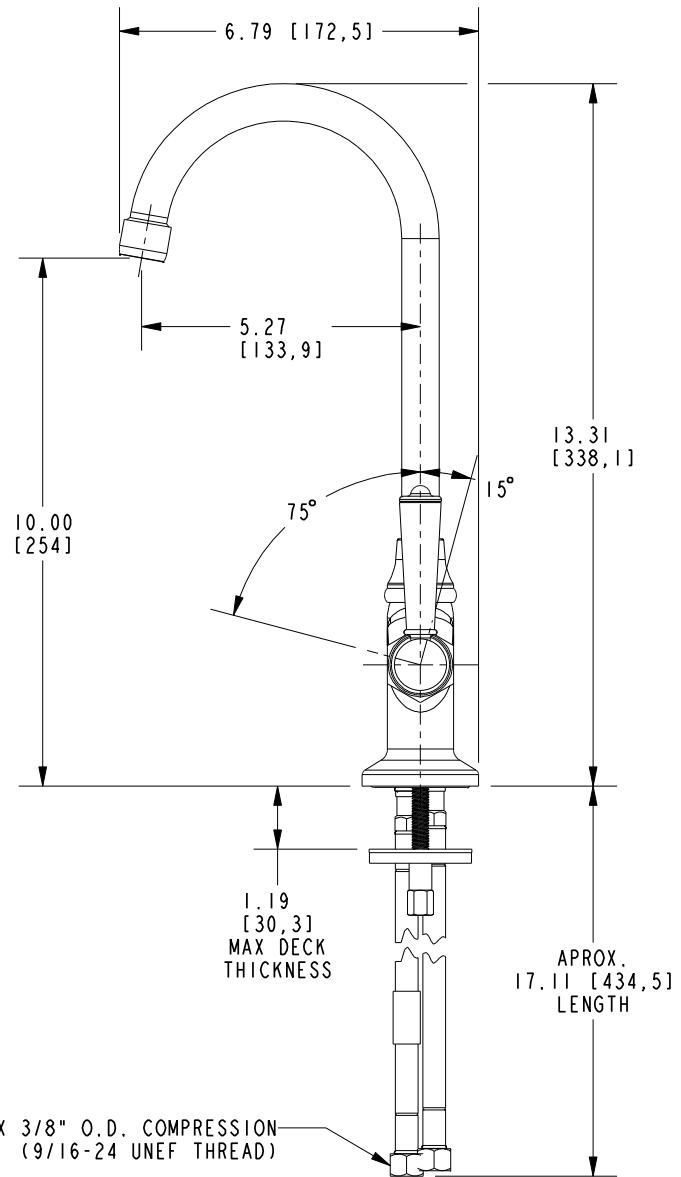
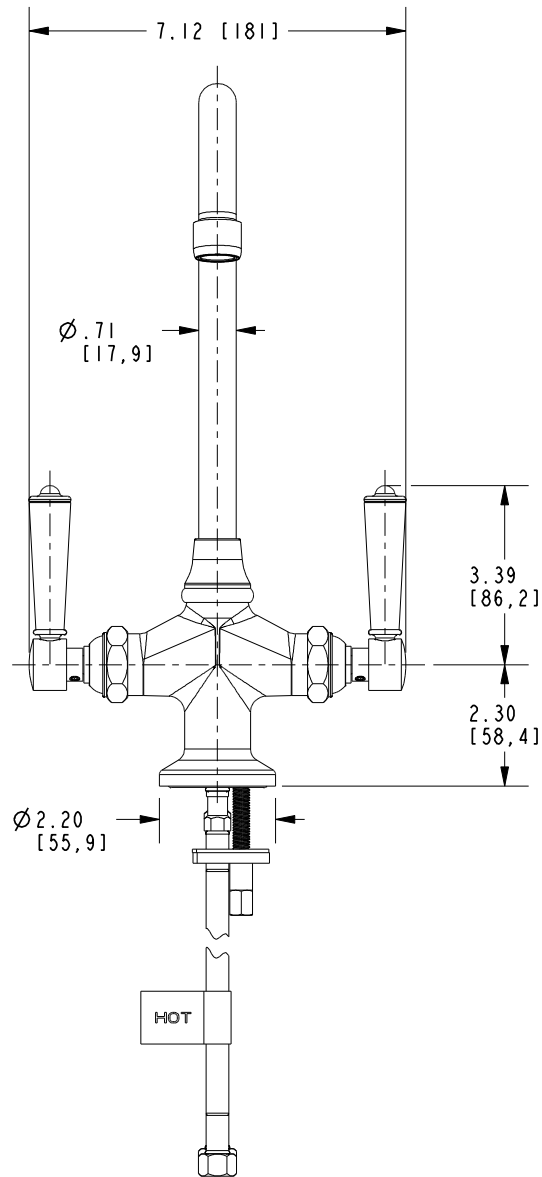

BRASSTECH		2001 E. CARNEGIE AVE. SANTA ANA, CA 92705 (949) 417-5207	
DWG NO.	1208	REV	E
SCALE	.275	REF.	-
		SHEET	2 OF 2