

Maximum capacity : 110 kgs/242 Lbs

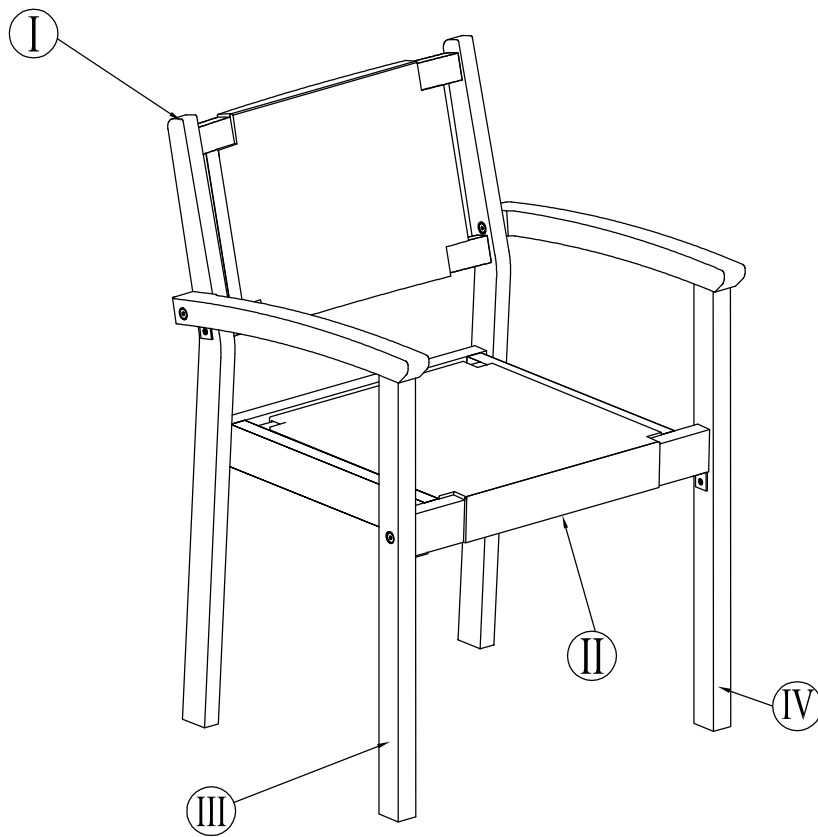







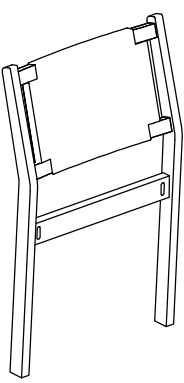
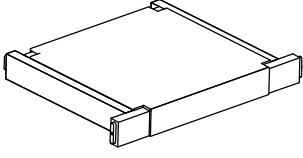
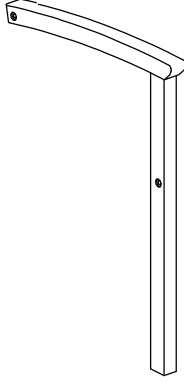
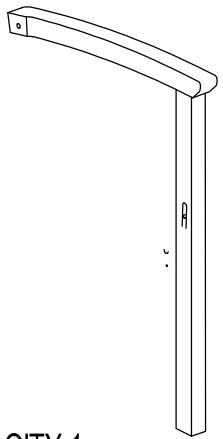

NOTE: 50% TIGHTEN BEFORE FIXING ALL BOLTS & SCREWS

### COMPONENTS LIST

 <p>Q'TY 1</p>	 <p>Q'TY 1</p>	 <p>Q'TY 1</p>	 <p>Q'TY 1</p>
---	---	--	---

### HARDWARE LIST

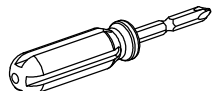
A		2	F - Screw 7x70	E		4	Metal Bracket
B		2	F - Screw 7x90	F		8	C- Screw 4x20
C		2	F - Bolt 8x50	G		2	Allen Key
D		2	Sleeve nut 8 x15	Supporting tools Screw driver			Page 2

# Step 1

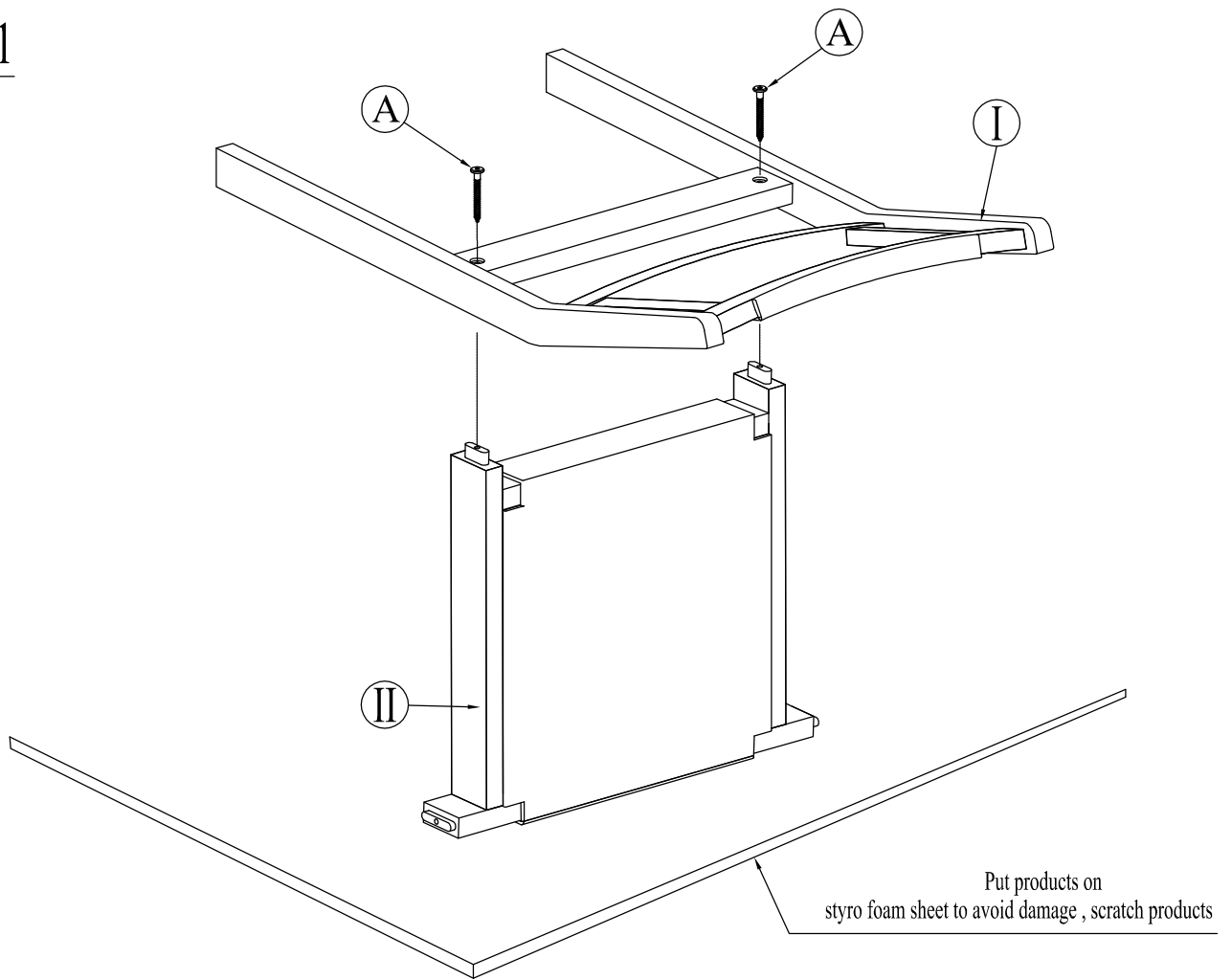

# Step 2

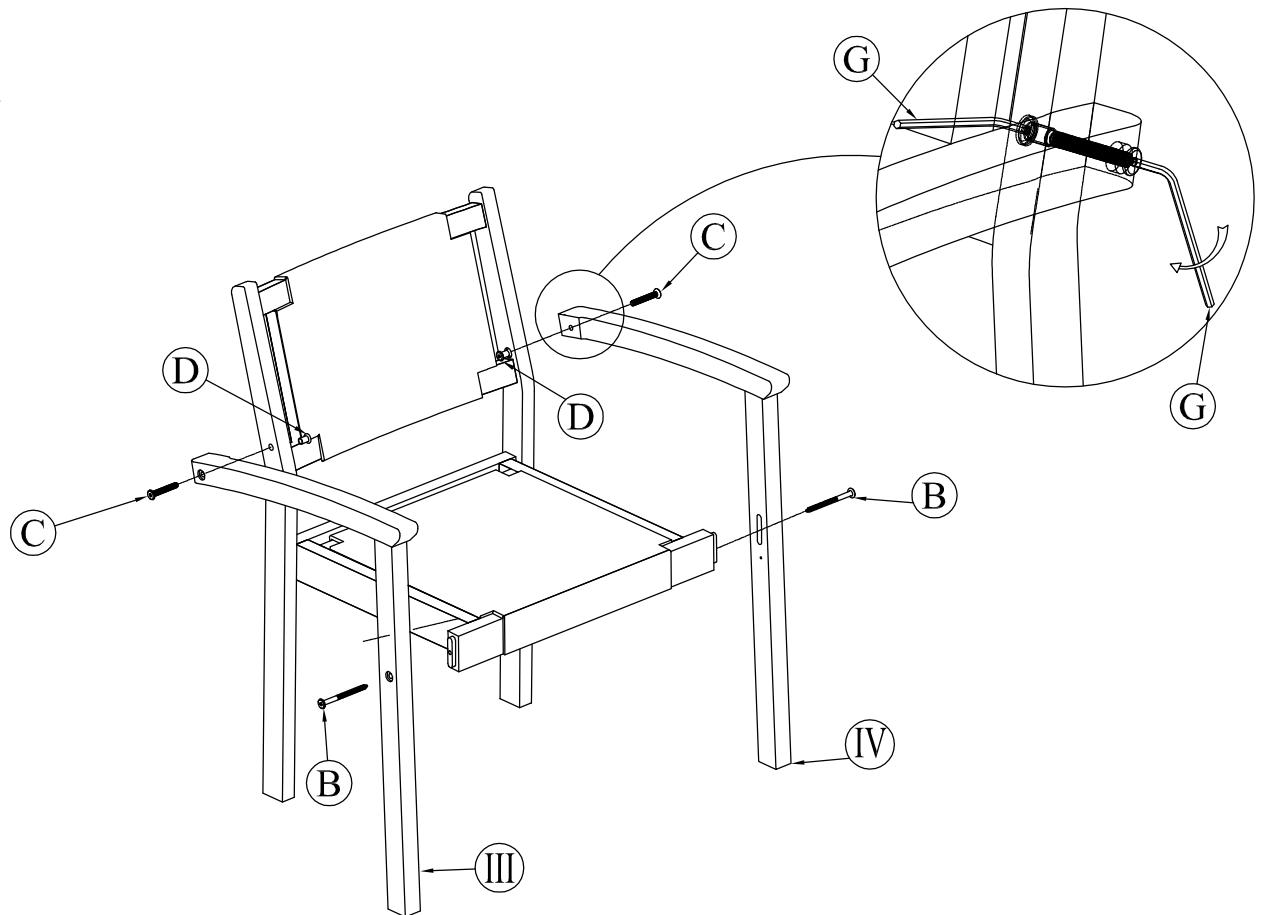

### Step 3

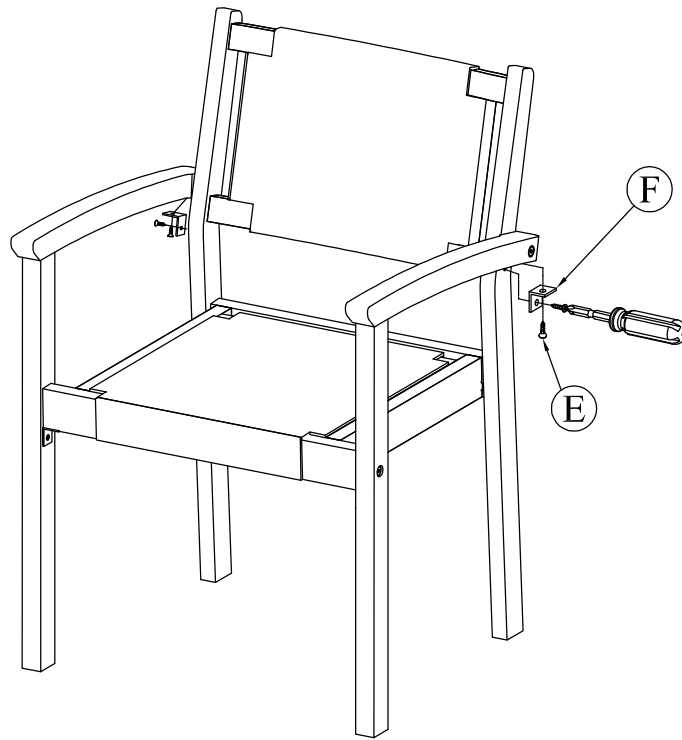

### Step 4

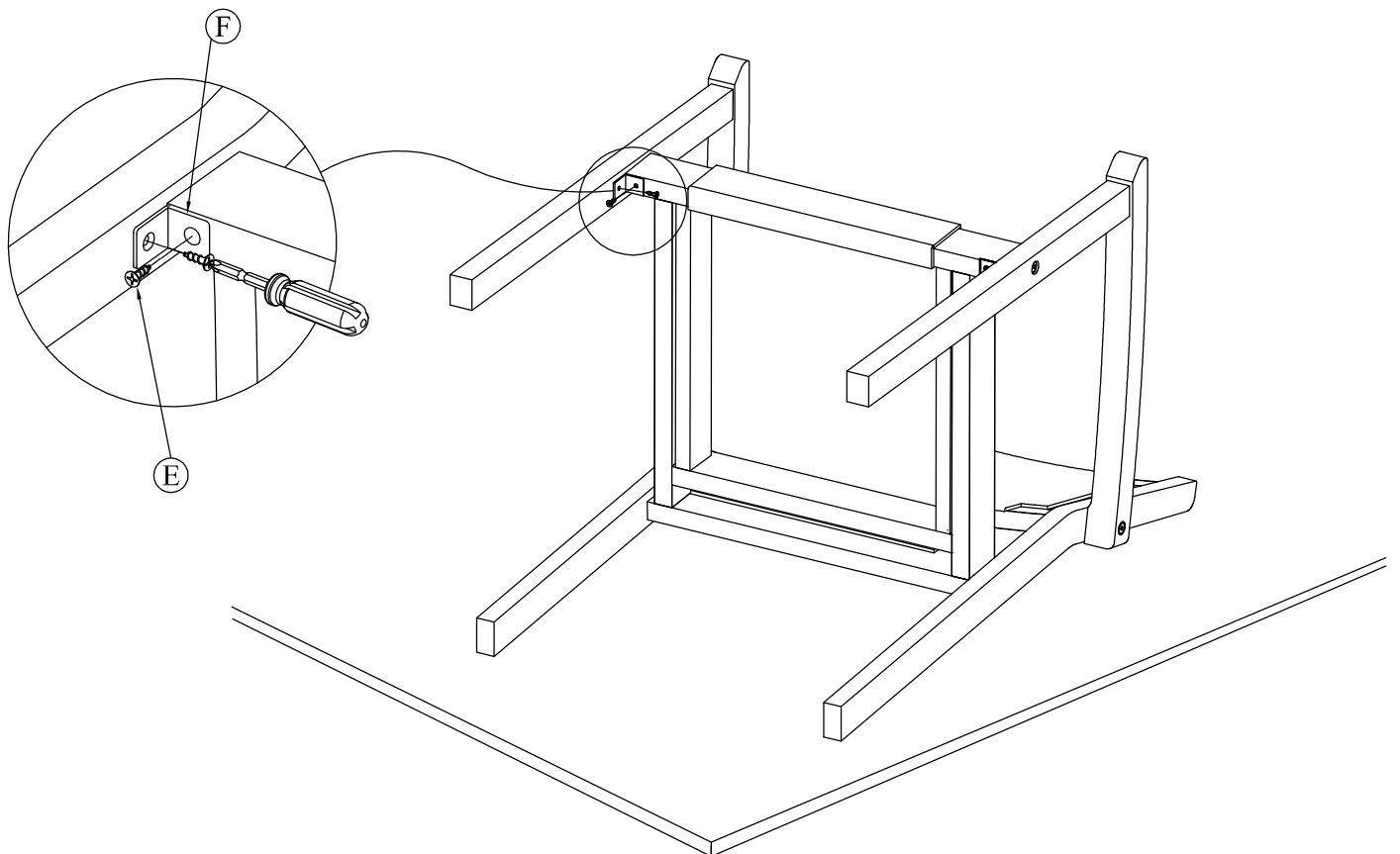

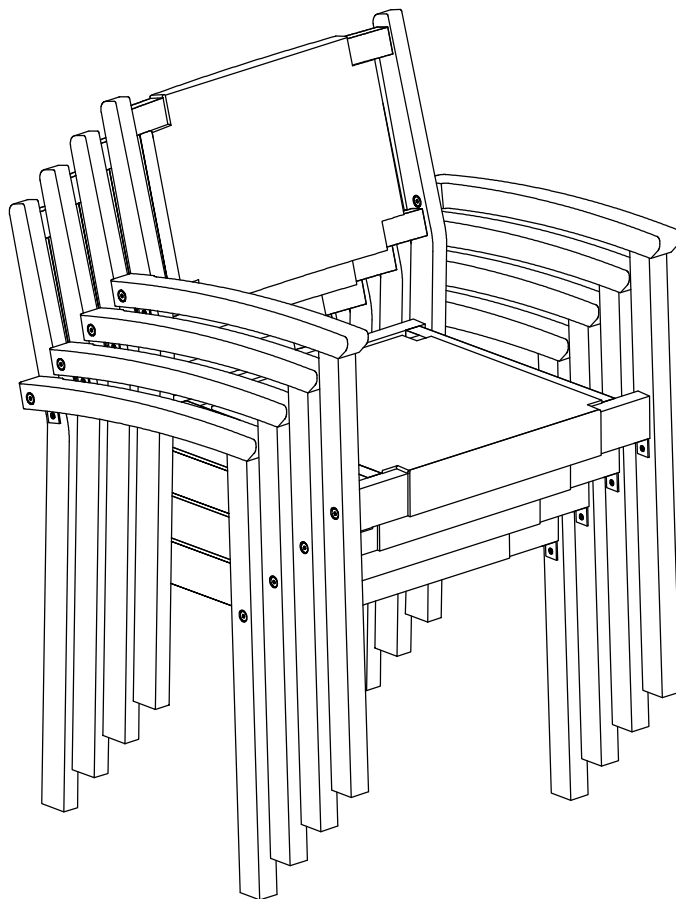
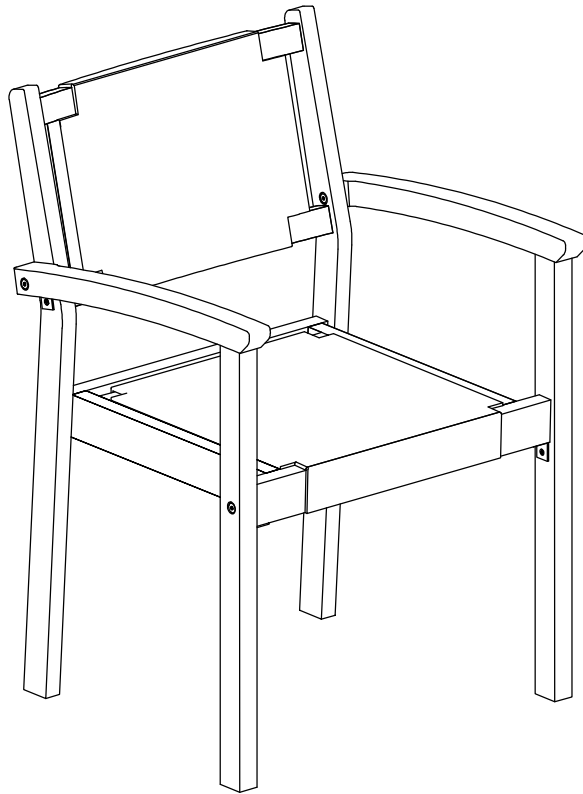

Warning: To ensure safety , please should not stack more than 4 chairs