

FOLDING WICKER CAFÉ TABLE

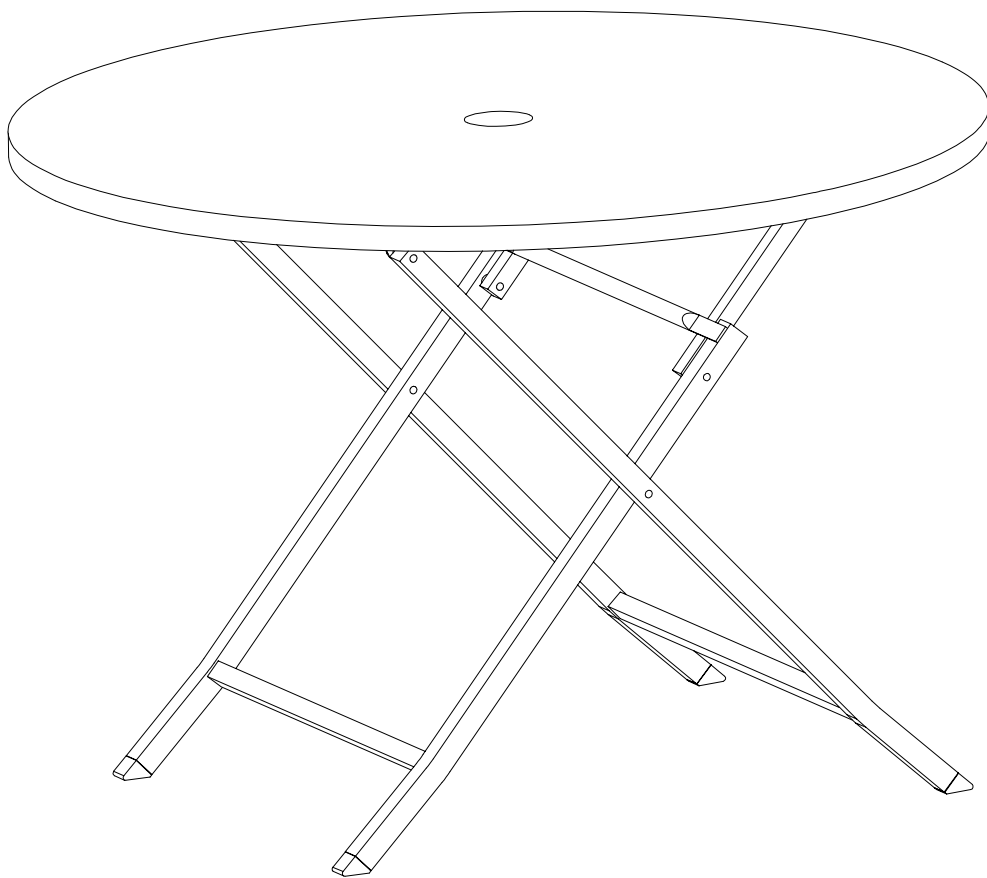

Congratulations! You have purchased a stylish piece of us .
We strived to provide fine furniture products, built with quality materials and hand finished details. Please carefully follow the assembly instructions to ensure your furniture is assembled correctly to provide long lasting enjoyment.



Should you experience any missing or damaged parts.**do not return to the store**,Please visit our website or contact usdirectly

Care: Use a soft, clean cloth that will not scratch the surface when cleaning. The use of solvents is not necessary. Should you choose to use solvents, test in an inconspicuous area first to avoid damaging the finish. TO clean, simply use a soft, clean cloth lightly dampened with water.

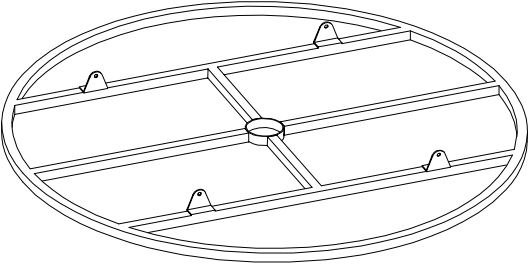
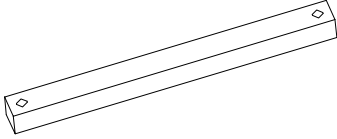
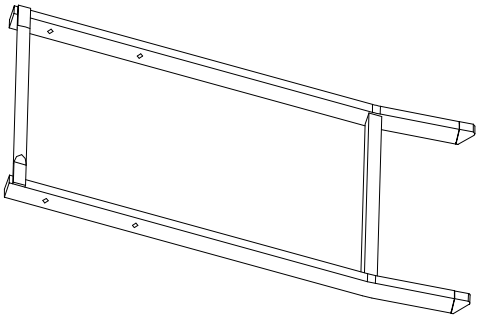
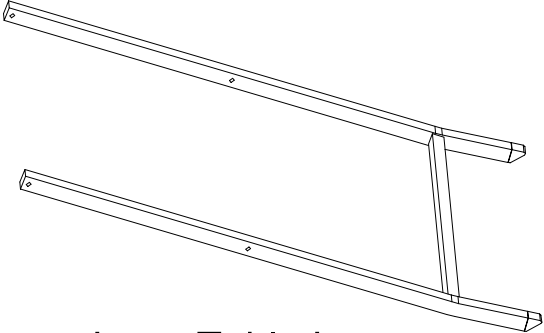
PART LIST

 <p>Table Top</p>		 <p>Connecting Bar</p>	
A	1pc	B	2pcs
 <p>Short Table Leg</p>		 <p>Long Table Leg</p>	
C	1pc	D	1pc

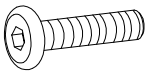
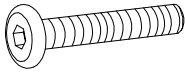
HARDWARE LIST

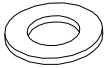
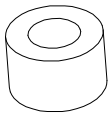
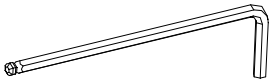
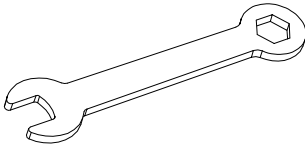
 <p>Short Bolt(M6*45mm)</p>		 <p>Long Bolt(M6*68mm)</p>		 <p>Nut(M6mm)</p>		 <p>Flat Washer(M6mm)</p>	
E	4pcs	F	4pcs	G	8pcs	H	16pcs
 <p>Plastic Washer</p>		 <p>Allen Key(M6mm)</p>		 <p>Wrench(M6mm)</p>			
I	8pcs	J	1pc	K	1pc		

Step 1. Lay the Table Top (A) down on a flat surface, and attach each Connecting Bar (B) to the Triangle Sheet Iron using a Short Bolt (E), Flat Washer (H), Plastic Washer (I), and Nut (G).

Note: Please do not tighten bolts before fully completing all assembly steps.

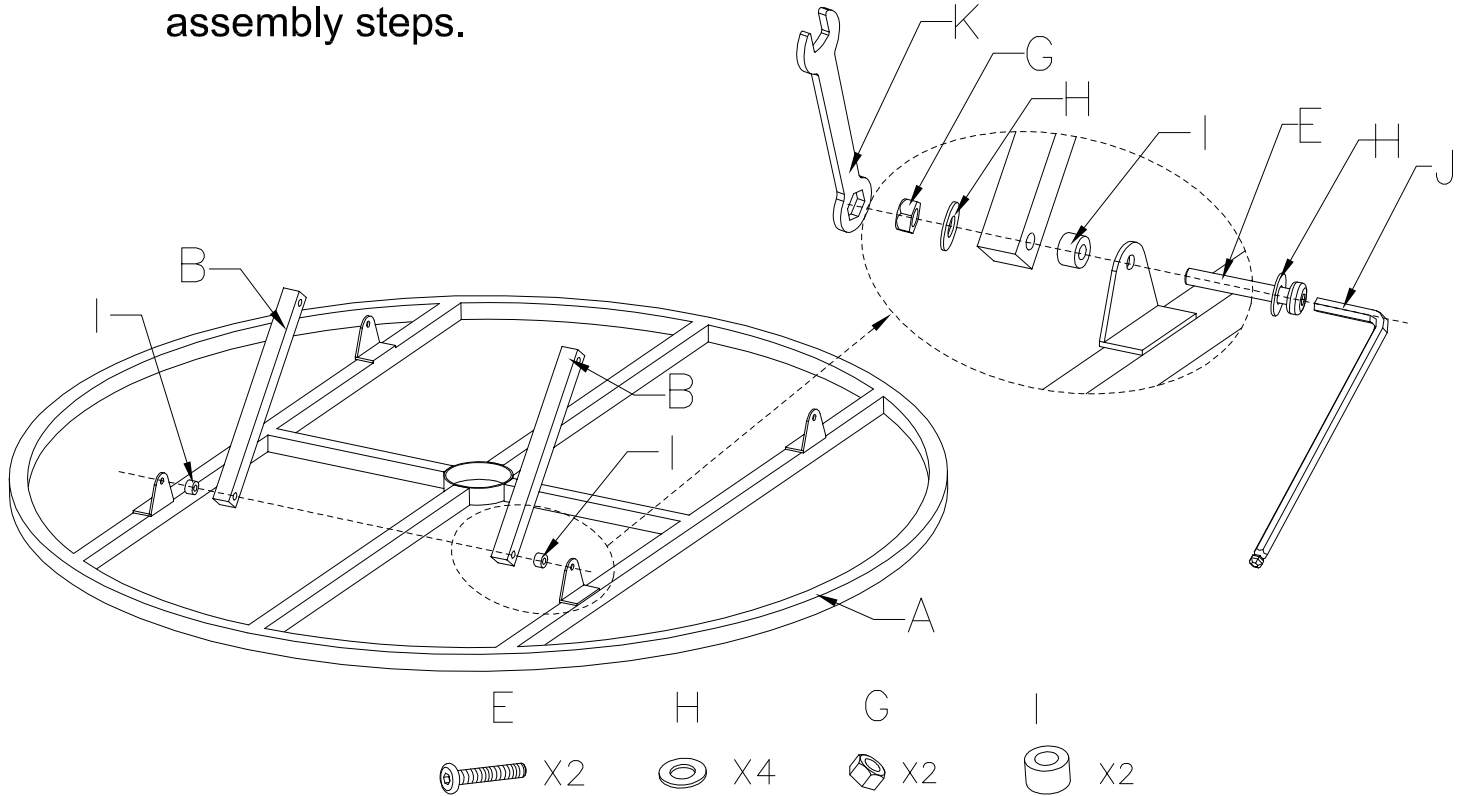

Step 2. Attach the Short Table Leg (C) to the Connecting Bars (B) using a Long Bolt (F), Flat Washer (H), Plastic Washer (I) and Nut (G).

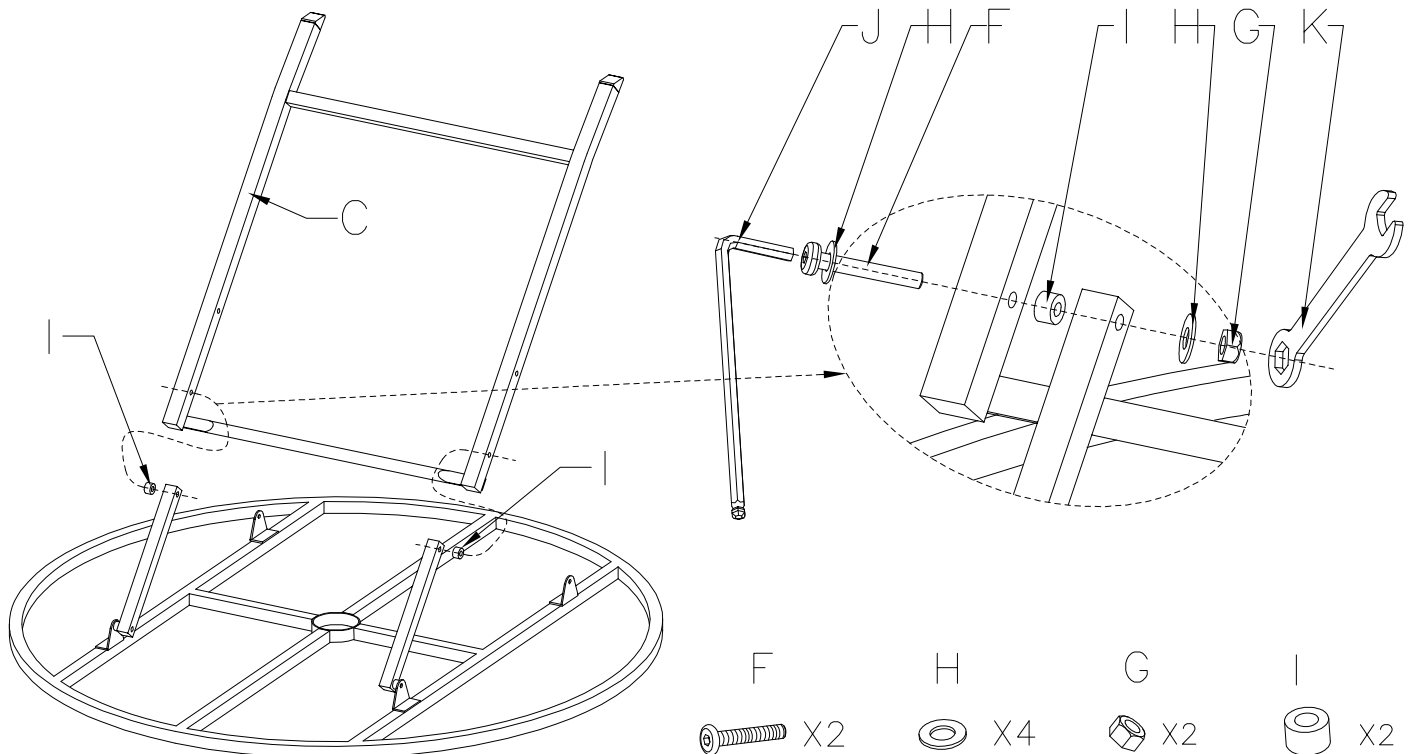

Step 3. Attach the Long Table Leg (D) to the Short Table Leg (C) with a Long bolt (F), Flat Washer (H), Plastic Washer(I) and Nut (G).

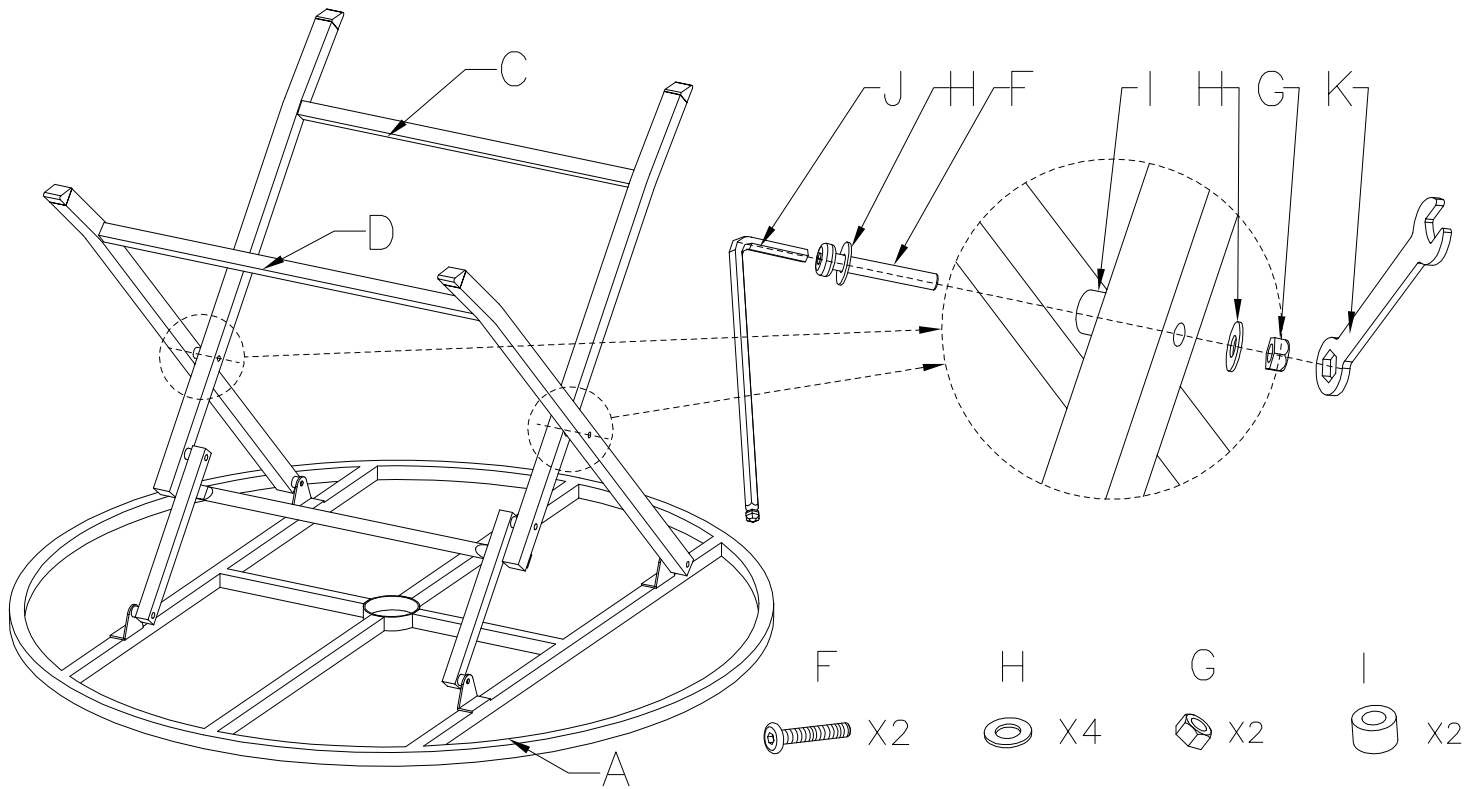

Step 4. Lock the Long Table Leg (D) to the Triangle Sheet Iron with Short Bolt (E), Flat Wahser (H), Plastic Washer(I) and Nut (G).

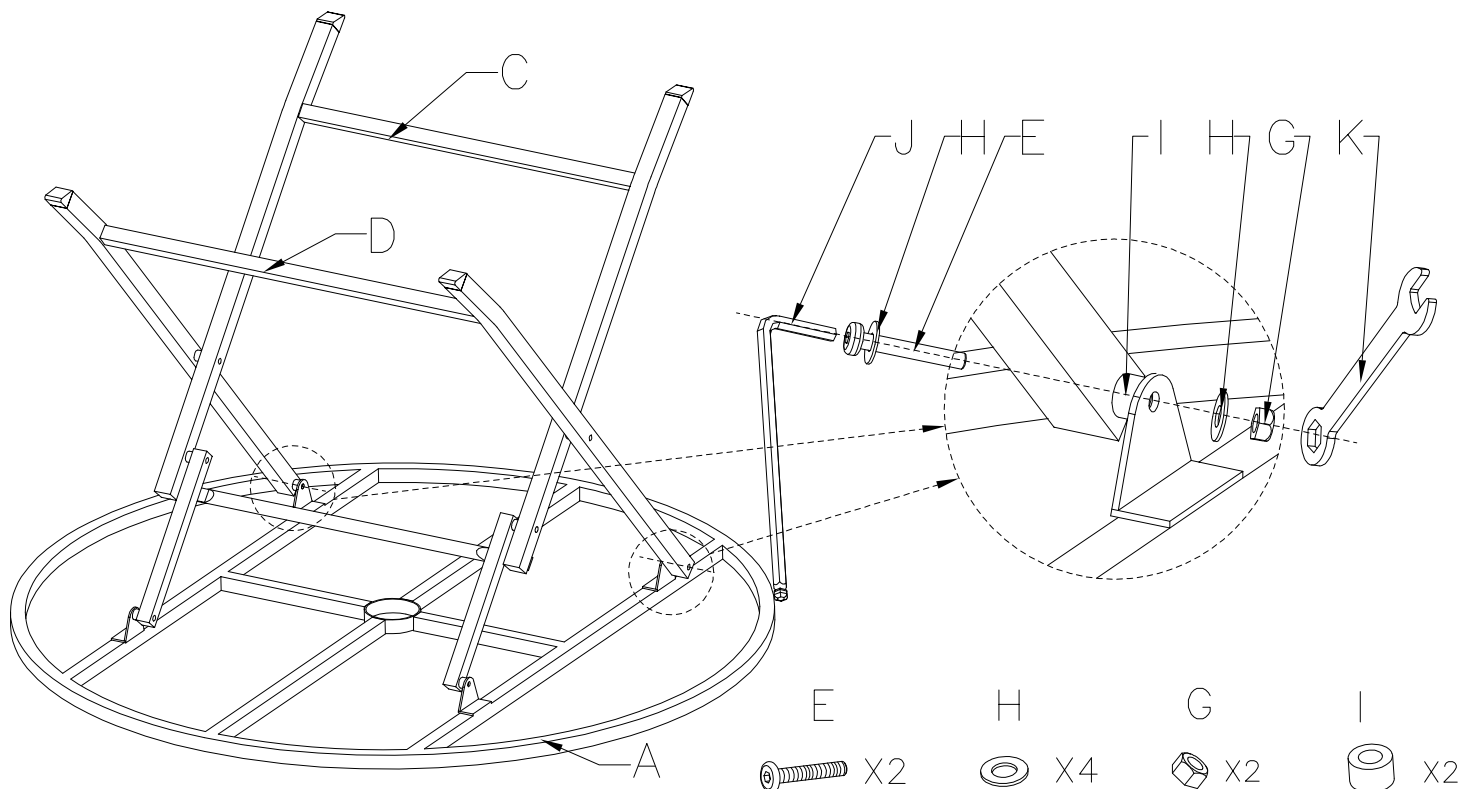

Step 5. Turn the assembled table upright on a flat surface.

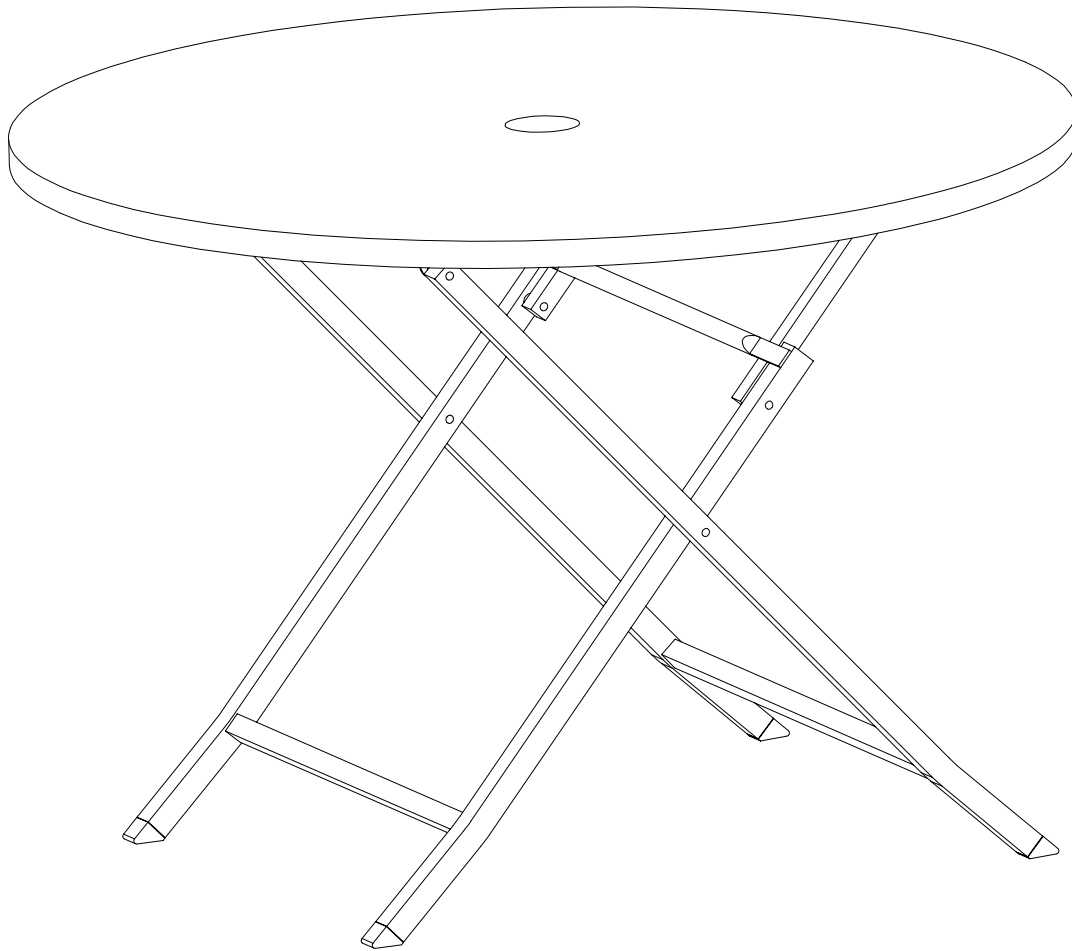

Limited Manufacturers Warranty

Our Products are warranted against defects in material and workmanship for a period of 90 days beginning from the date of sale. Should any parts be missing or defective, we will replace or repair the parts for a period of 90 days from the date of purchase.

Should you experience any missing or damaged parts, do not return to the store. Please contact us directly

This warranty gives the purchaser specified legal rights in addition to any rights which may vary from state to state.

In accordance with the "Moss-Magnuson Warranty Act" of July 10, 1975, this is termed a "limited warranty" which in no way compromises our high standards of Quality and Workmanship.