

3

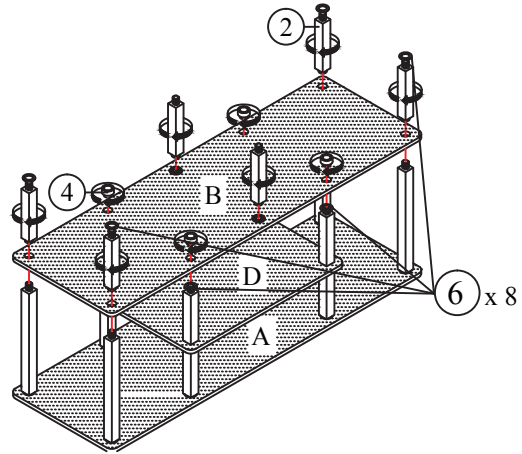

4

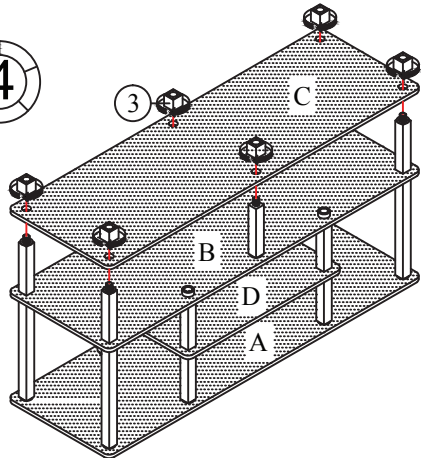

5

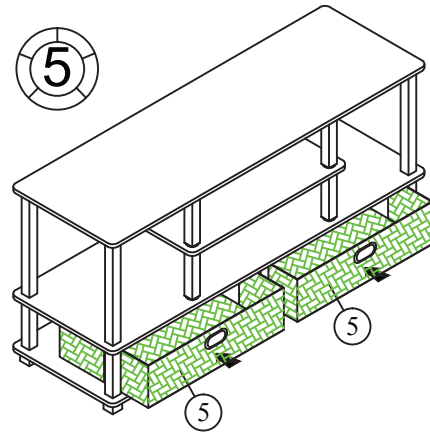

Recommended Maximum Weight

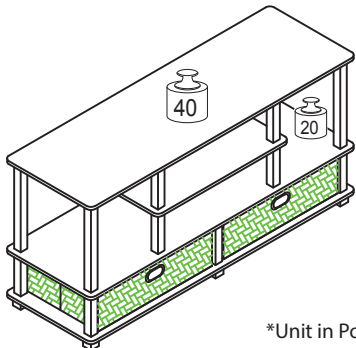

*Unit in Pound(lbs)

WARNING:

>This unit has been designed to support the maximum loads shown. Exceeding these load limits could cause sagging, instability, product collapse, and/or serious injury.

>DO NOT allow children to climb on unit.

>Put heavier items on lower shelves.

Assembly Instruction

TV Stand

00:30

Approx. 30 minutes







Recomm. 1 Person

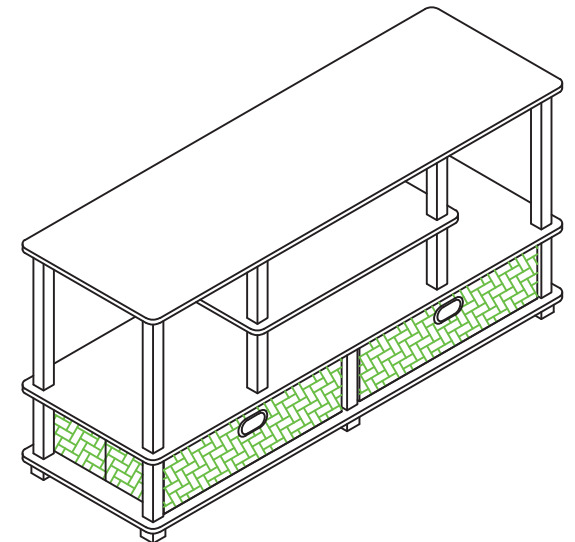

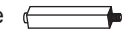
No Tools Required



No	Hardware List	Qty
1	Long Square Pole 	4pcs
2	Short Square Pole 	14pcs
3	Square Leg 	6pcs
4	Small Round Leg 	4pcs
5	Non-Woven Bin 	2pcs
6	PVC Round Ring 	12pcs

No	Parts List	Qty
A	Top Panel	1pc
B	Center Panel	1pc
C	Bottom Panel	1pc
D	Shelf Panel	1pc

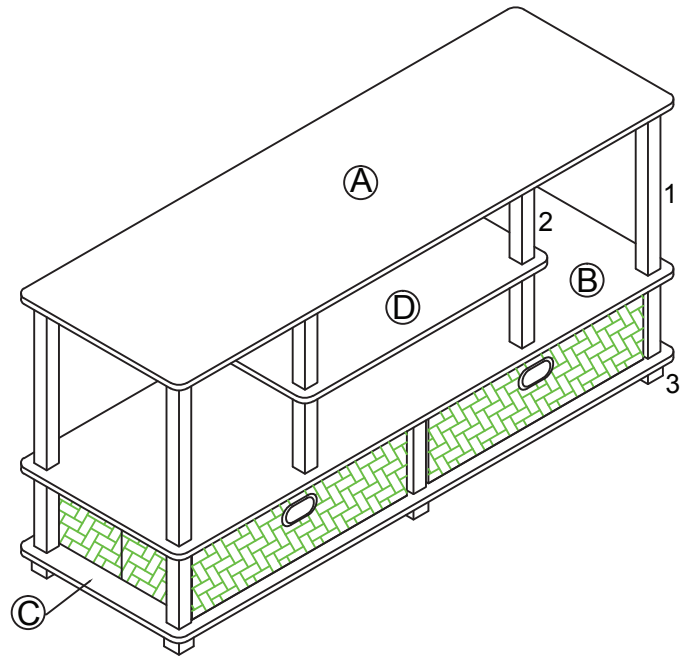

USEFUL HINTS BEFORE YOU START:

1. Read each step carefully before starting.
2. It is important that each step is performed in correct order to avoid difficulties.
3. Identify, sort and count the parts before assembly.
4. Assemble your furniture on packaging cardboard to prevent scratch or damage.
5. Clean the product with mild cleanser using soft damped cloth. Do not use harsh or abrasive cleanser.
6. Using incompatible hardware might cause damage to product.

ASSEMBLY INSTRUCTION

1

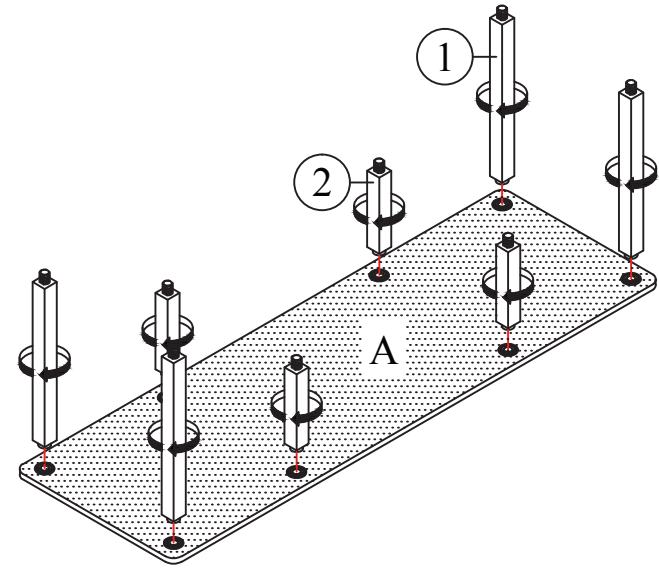

2

