

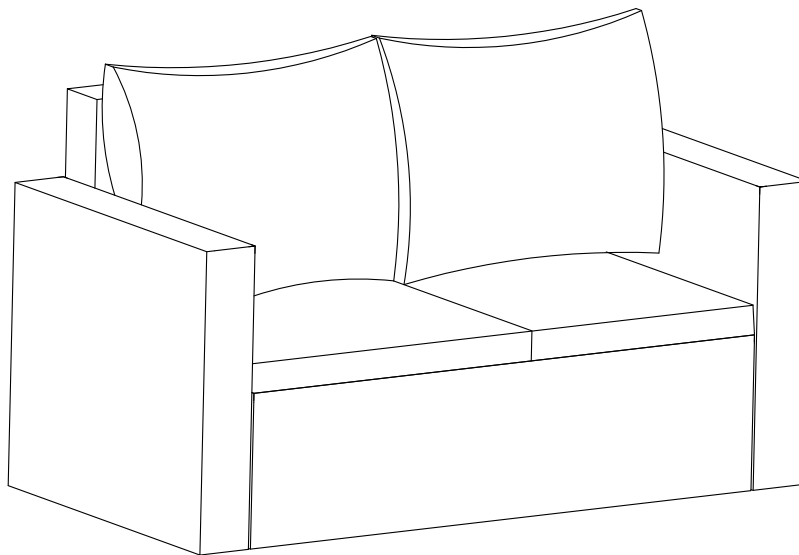

ASSEMBLY INSTRUCTIONS

Laguna Sofa & Table Set
Part 1

So Comfortable,
You'll feel the difference
the moment you sit down.



Should you prefer to
speak with a customer
service representative,
you may call toll free :

1-855-372-2315.

Limited Warranty

Millwork Holdings seating products are warranted against defects in material and workmanship while owned by the “Original Purchaser”. The term “Original Purchaser” is defined as that party or entity which purchases Millwork Holdings furniture from an authorized Millwork Holdings retailer as shown by the original sales receipt. This warranty does not apply to “as is” or previously owned seating products.

Millwork Holdings warrants its products to be free from defects in materials and workmanship (normal wear and tear, fading and stretching excepted), for one year from the date of purchase, except as provided below under the limited warranty.

This warranty gives you specific rights, and you may also have other rights, which vary from state to state. All warranties are limited to the original purchaser for normal use by a maximum of two users. Total weight capacity per chair is 250 pounds for a single user.

the exceptions or exclusions to this warranty are:

- Upholstery material and foam cushion material is warranted against defects in material and workmanship for a period of one year, beginning on the date of purchase as shown on the original sales receipt.
- Any warranty claim that is submitted after the limited warranty period, or without proper proof of purchase will not include the cost of parts, labor, or delivery on the warranted parts within a reasonable amount of time. We reserve the right to require damaged parts to be returned to us upon request. Natural markings such as scars, brands, grain variations, wrinkles, color variations, etc. will be considered normal characteristics and not construed as defects.
- For claims or questions concerning this warranty, please contact Millwork Holdings Customer Service department on the web at www.truecustomersupport.com. Be prepared to provide your name, address, daytime phone number, the model and purchase order number of the product, date of purchase, and the store where it was purchased. Millwork Holdings requires that the original sales receipt be submitted with all requests to confirm that you are the original purchaser according to our written warranty.

Guidelines

Thank you for selecting a Serta furniture piece!

Our primary objective is to provide fast, friendly customer service to all of our customers. We are here to help if you have any questions, comments, or are in need of warranty replacement parts.

Please call us toll free at: 1-855-372-2315
(Monday - Friday 6:00am - 5:00pm PST)

Or visit our website:
www.truecustomersupport.com
www.trueinnovations.com

Or call us toll free: **1-800-379-9973**

FAILURE TO FOLLOW THESE WARNINGS WHEN IN USE COULD RESULT IN INJURY

- Do not stand on the item or use as a step ladder
- The seat has been tested and approved for users weighing up to 250 lbs (113kg) per seat.
- Do not use this item unless all bolts and screws are firmly secured and fastened.
- Check all bolts and screws every 90 days. As necessary tighten if any are loose.
- Lift up then move. Pushing over or dragging this product can result in an injury or cause damage to the floor and outdoor piece.

WARNING: DO NOT LET CHILDREN PLAY IN OR AROUND THE UNIT DUE TO THE POSSIBLE RISK OF INJURY.

Pre-Assembly Preparation:

Please read through this instruction before beginning assembly of this item.





Two adults assembly are recommended.





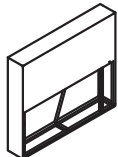
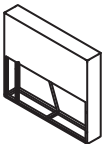

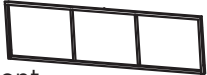
- Clear out space for assembly and lay out all parts shown in parts list. Extra room will allow you to easily determine if all the pieces are present.
- Save all packing materials until assembly is complete to avoid accidentally discarding smaller parts or hardware.
- Keep small parts and pieces away from children until fully assembled.
- Please check for any loose screws and tighten them before you use.

Cleaning & Maintenance:

- Wash frame parts with mild soap and water, rinse thoroughly. Dry frame parts completely. Do not use bleach, acid or other solvents on the wicker or metal parts.
- We recommend the use of furniture covers to protect the set when not in use.
- Inspect and tighten all bolts on a regular basis to ensure proper performance and safety.
- In order to prolong the life of your outdoor furniture, we recommend storing it in a dry and protected area during off season periods.

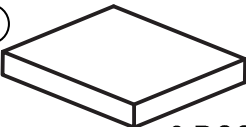
Parts & Assembly - Sofa

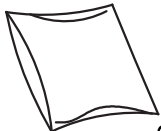
PARTS	
<p>①</p>  <p>Left Panel 1 PC</p>	<p>④</p>  <p>Right Panel 1 PC</p>
<p>②</p>  <p>Back Panel 1 PC</p>	<p>⑤</p>  <p>Front Panel 1 PC</p>
<p>③</p>  <p>Seat Panel 1 PC</p>	<p>⑥</p>  <p>Base Panel 1 PC</p>

PARTS	
<p>Ⓐ</p>  <p>M6*35 bolt 8 PCS</p>	<p>Ⓔ</p>  <p>Fixing Panel 2 PCS</p>
<p>Ⓑ</p>  <p>M6 Washer 12 PCS</p>	<p>Ⓛ</p>  <p>Seat Cushion 2 PCS</p>
<p>Ⓒ</p>  <p>M6*15 bolt 4 PCS</p>	<p>Ⓜ</p>  <p>Back cushion 2 PCS</p>
<p>Ⓓ</p>  <p>Allen Key 1 PC</p>	

Assembly:

Please note, the box is well engineered to fit all the pieces of the sofa in it. Check that all layers have been unpacked to locate all the pieces.

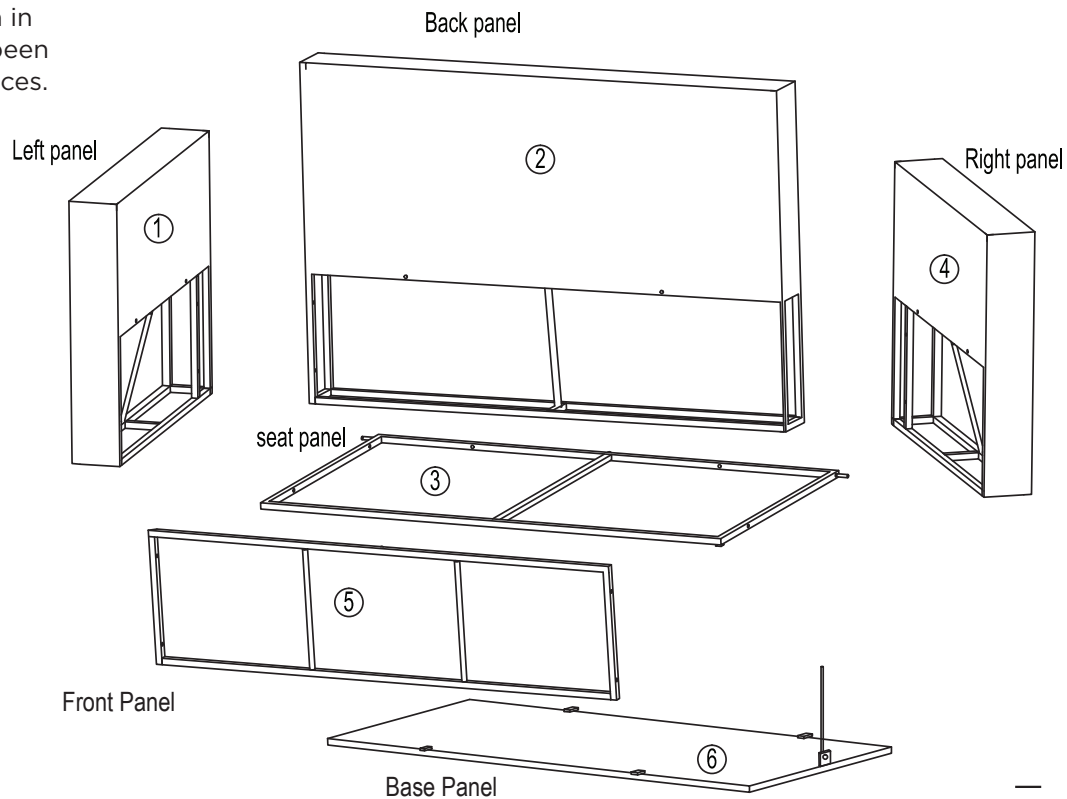

NOTE: DO NOT FULLY TIGHTEN BOLTS UNTIL ALL PARTS ARE ASSEMBLED.

① Step One:

Attach Left Side panel (1) to Back Panel (2) by using M6*35 bolt (A) and Washer (B). Fasten with Allen Key (D).

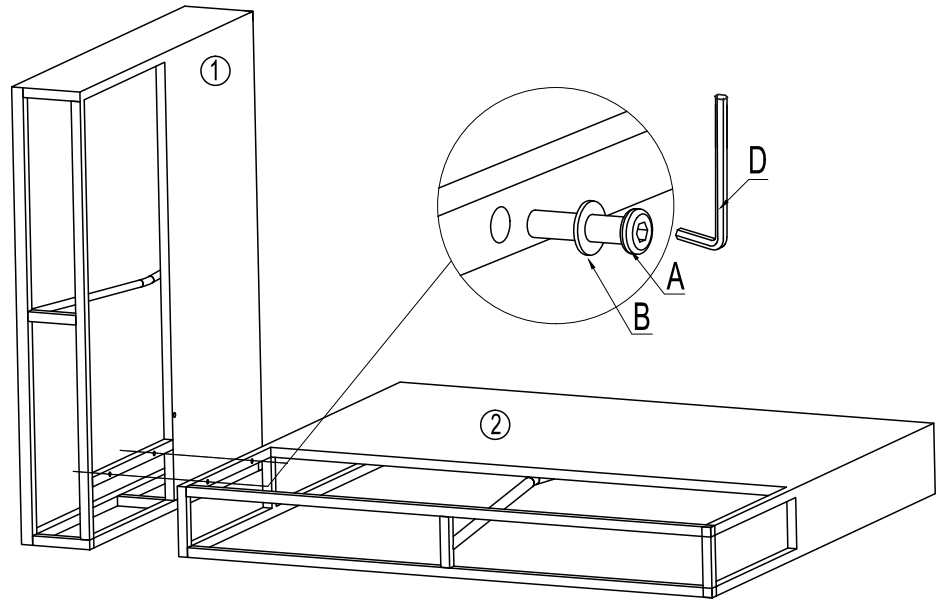

② Step Two:

Attach Seat panel (3) to assembled panels (1) and (2).

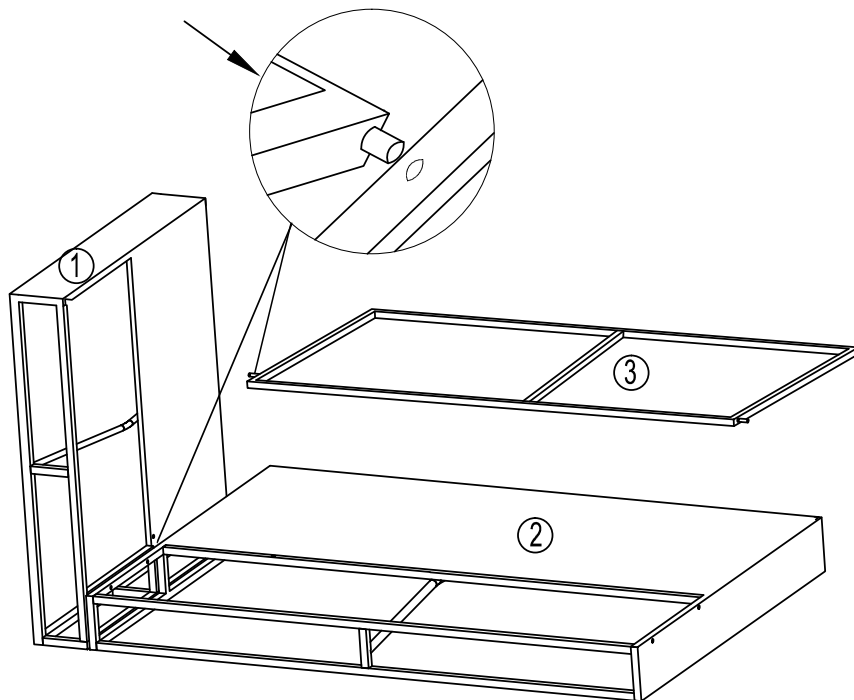

NOTE: DO NOT FULLY TIGHTEN BOLTS UNTIL ALL PARTS ARE ASSEMBLED.

③ Step Three:

Attach Right Side Panel (4) to assembled Panels (1), (2) & (3) by using M6*35 bolt (A) and Washer (B). Fasten with Allen Key (D).

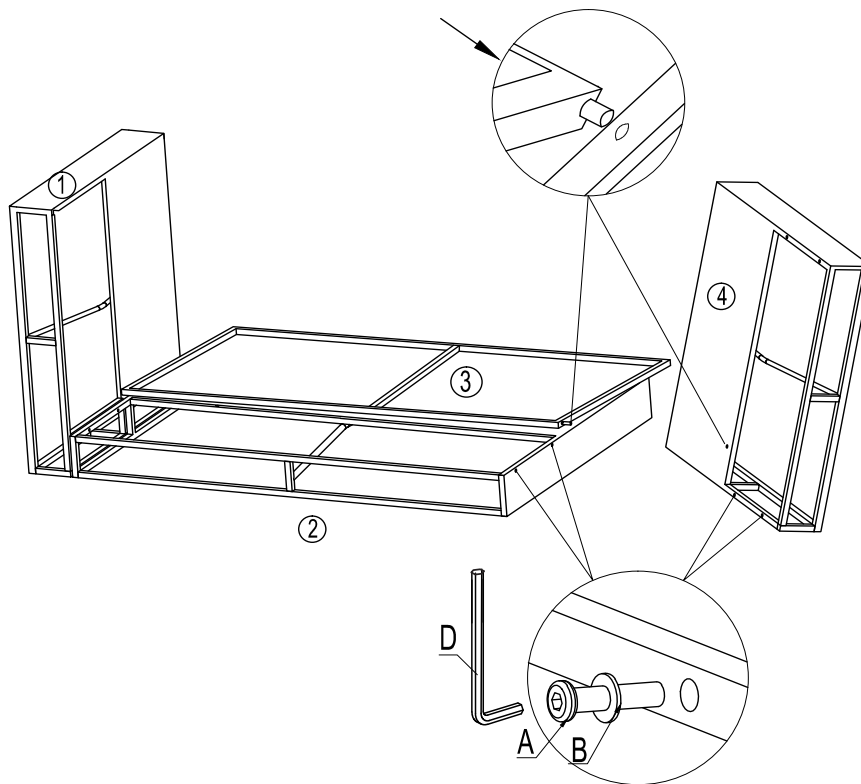

NOTE: DO NOT FULLY TIGHTEN BOLTS UNTIL ALL PARTS ARE ASSEMBLED.

④ Step Four:

Attach Front Panel (5) to panels (1) & (4), by using M6*35 bolt (A) with Washer (B). Fasten with Allen Key (D).

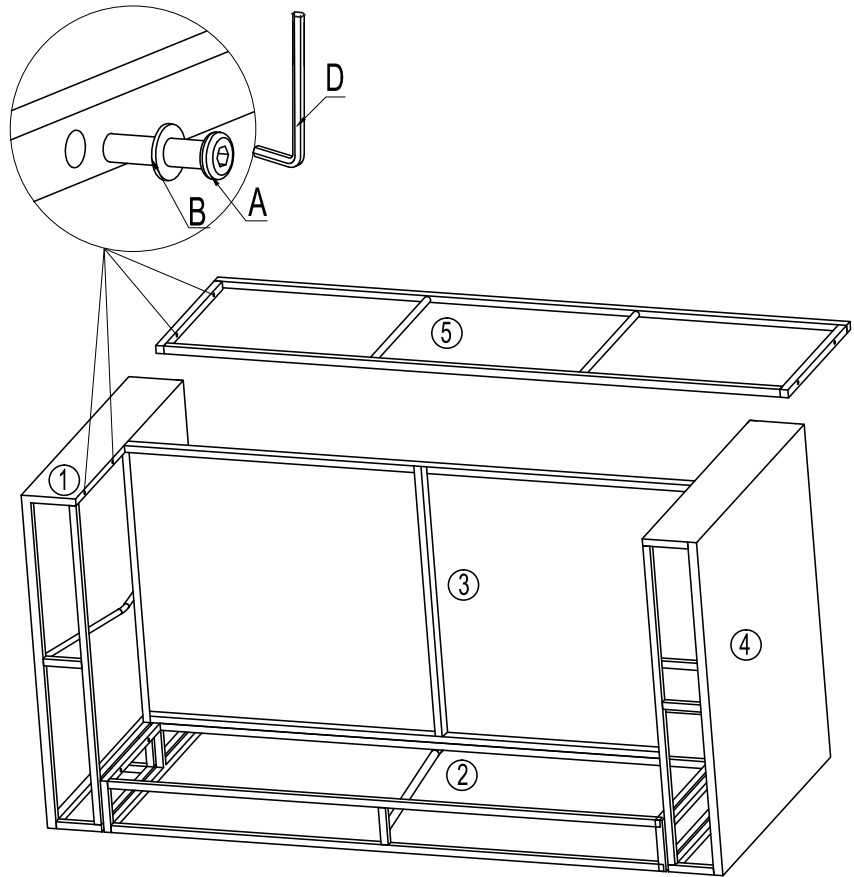

⑤ Step Five:

Lift up Seat Panel (3) then Attach Base Panel (6) to Back Panel (2) and Front Panel (5) by clicking into place.

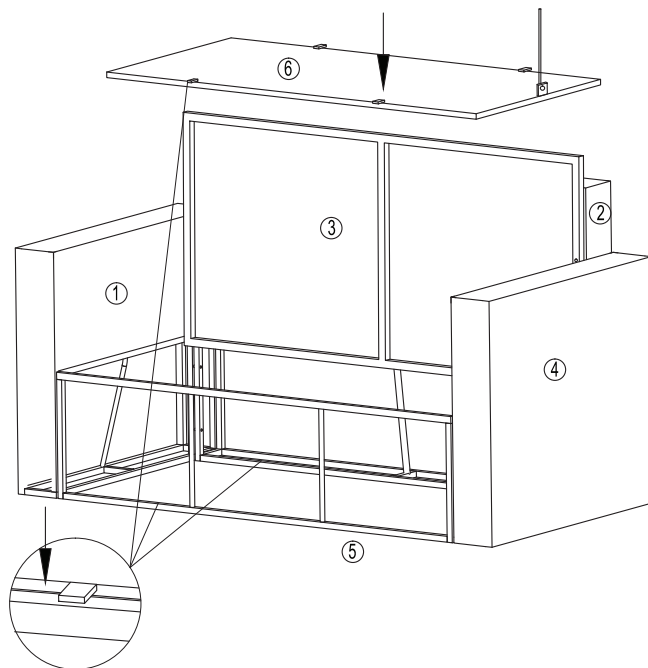
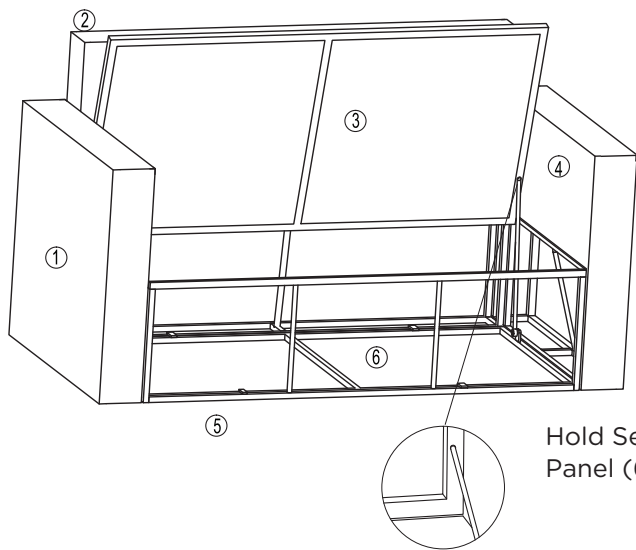

Hold Seat Panel (3) by the hook of Base Panel (6) when putting stuffs in the storage.

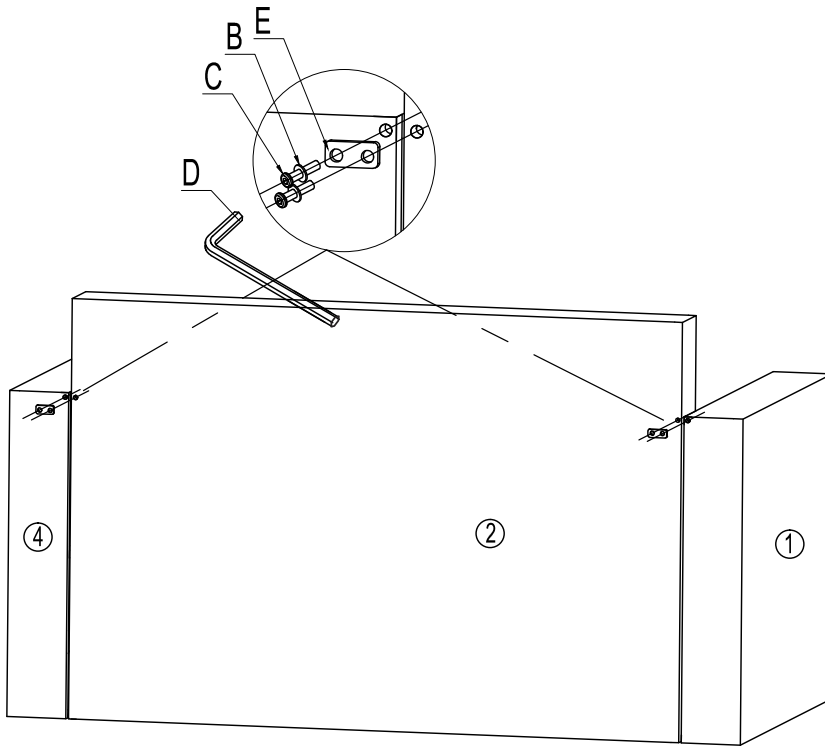

⑥ Step Six:

Attach Fixing Plates (E) by using M6*15 bolt (C) with Washer (B). Fasten with Allen Key (D).



ASSEMBLY





INSTRUCTIONS

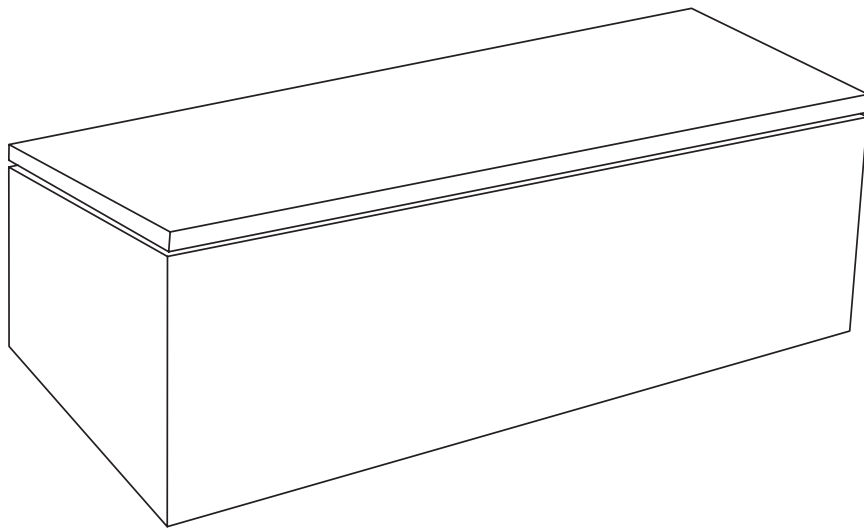

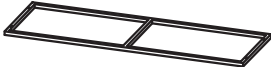
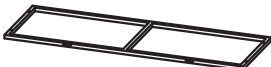

Laguna Sofa & Table Set
Part 2

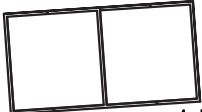
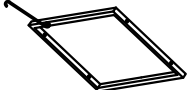
So Comfortable,
You'll feel the difference
the moment you sit down.



Parts & Assembly - Table

PARTS	
<p>⑦</p>  <p>Front Panel 1 PC</p>	<p>⑩</p>  <p>Back Panel 1 PC</p>
<p>⑧</p>  <p>Left Side Panel 1 PC</p>	<p>⑪</p>  <p>Base Panel 1 PC</p>
<p>⑨</p>  <p>Right Side Panel 1 PC</p>	<p>⑫</p>  <p>Lid 1 PC</p>

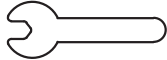
PARTS	
<p>Ⓐ</p>  <p>M6*35 bolt 12 PCS</p>	<p>Ⓕ</p>  <p>M4*25 bolt 6 PCS</p>
<p>Ⓑ</p>  <p>M6 washer 12 PCS</p>	<p>Ⓖ</p>  <p>nut 6 PCS</p>
<p>Ⓓ</p>  <p>Allen Key 1 PC</p>	<p>Ⓖ</p>  <p>wrench 1 PC</p>

Assembly:

Please note, the box is well engineered to fit all the pieces of the table in it. Check that all layers have been unpacked to locate all the pieces.

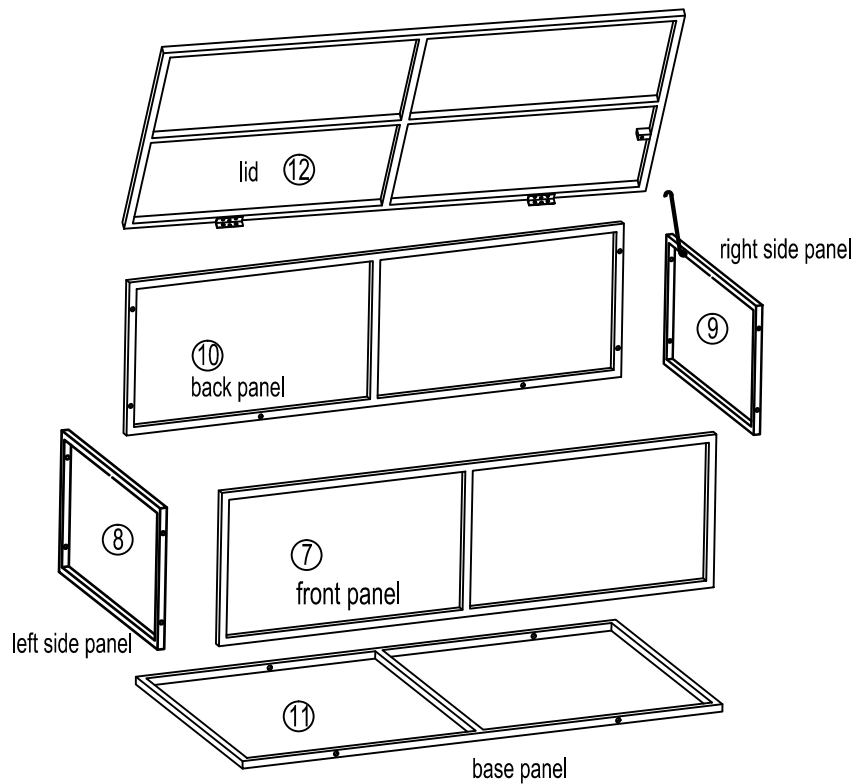

NOTE: DO NOT FULLY TIGHTEN BOLTS UNTIL ALL PARTS ARE ASSEMBLED.

① **Step One:**

Attach Front Panel (7) to Left Side Panel (8) by using M6*35 bolt (A) and washer (B) with Allen Key (D). Repeat with Right Side Panel (9).

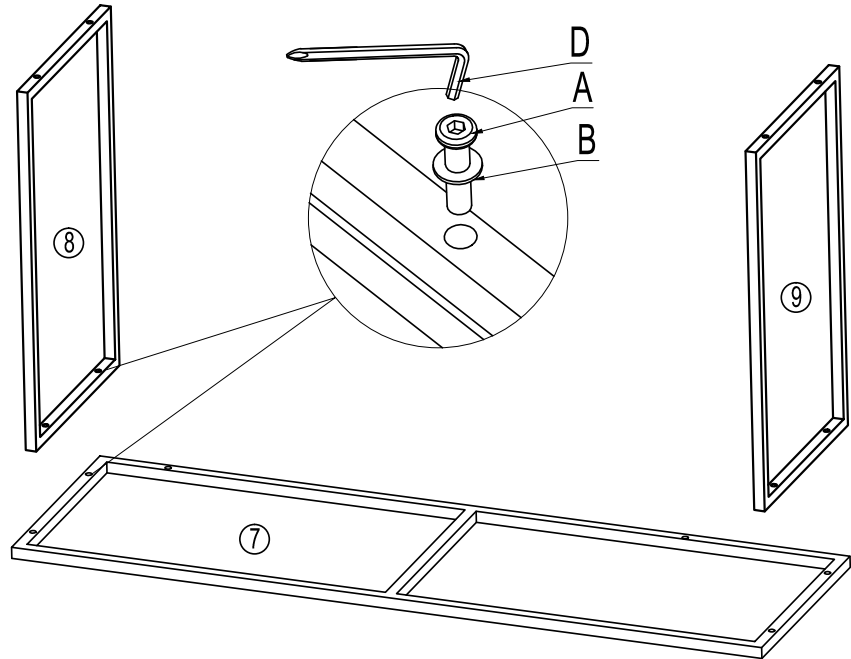

NOTE: DO NOT FULLY TIGHTEN BOLTS UNTIL ALL PARTS ARE ASSEMBLED.

② **Step Two:**

Attach Side Panels (8) and (9) to Back Panel (10) by using M6*35 bolt (A) and Washer (B) and fasten with Allen Key (D).

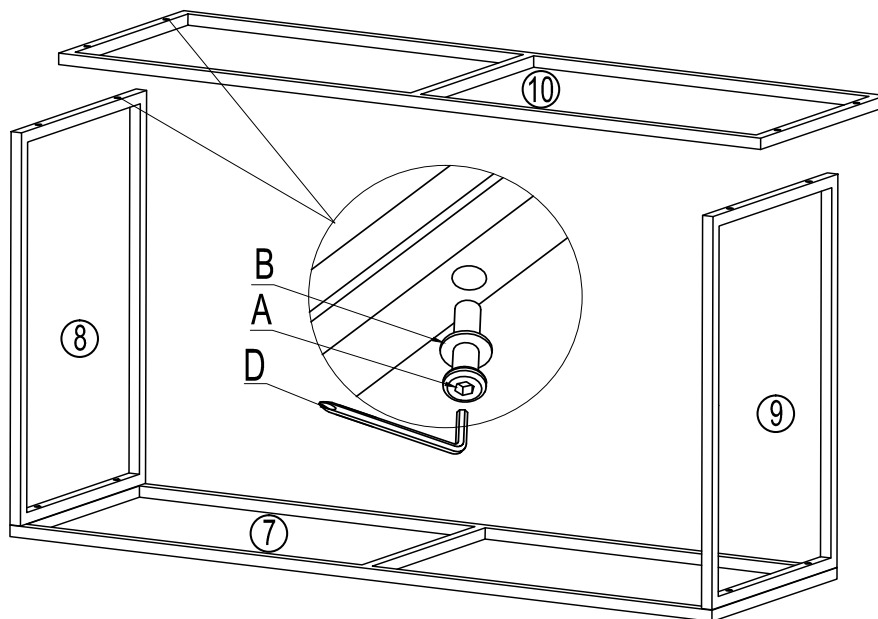

NOTE: DO NOT FULLY TIGHTEN BOLTS UNTIL ALL PARTS ARE ASSEMBLED.

③ Step Three:

Attach Base Panel (11) to Panels (7), (8), (9), and (10) by using M6*35 bolt (A) and Washer (B). Fasten with Allen Key (D).

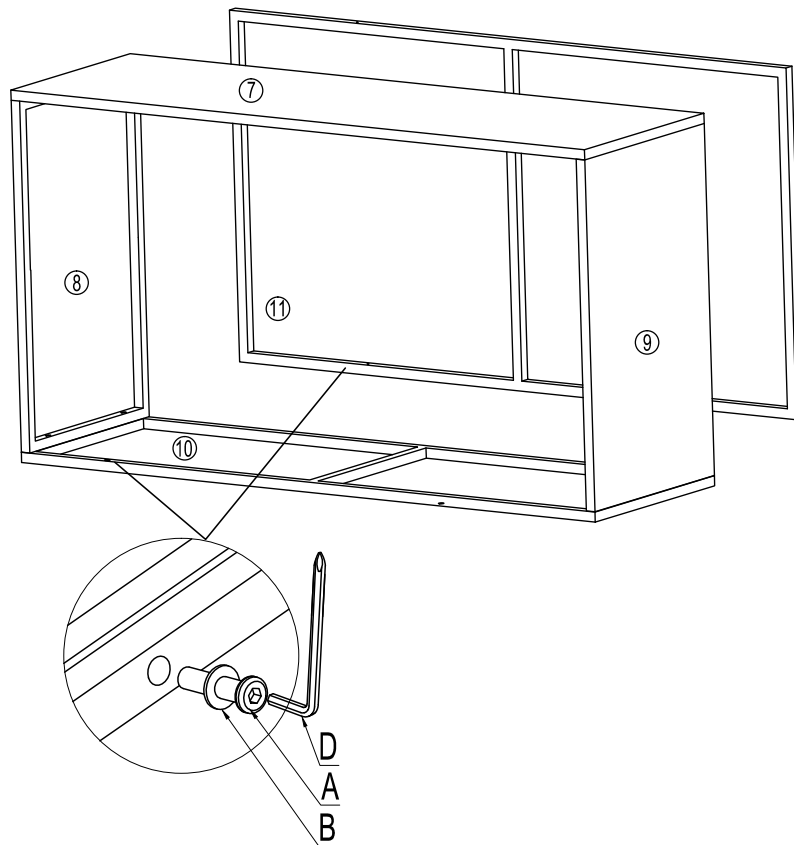

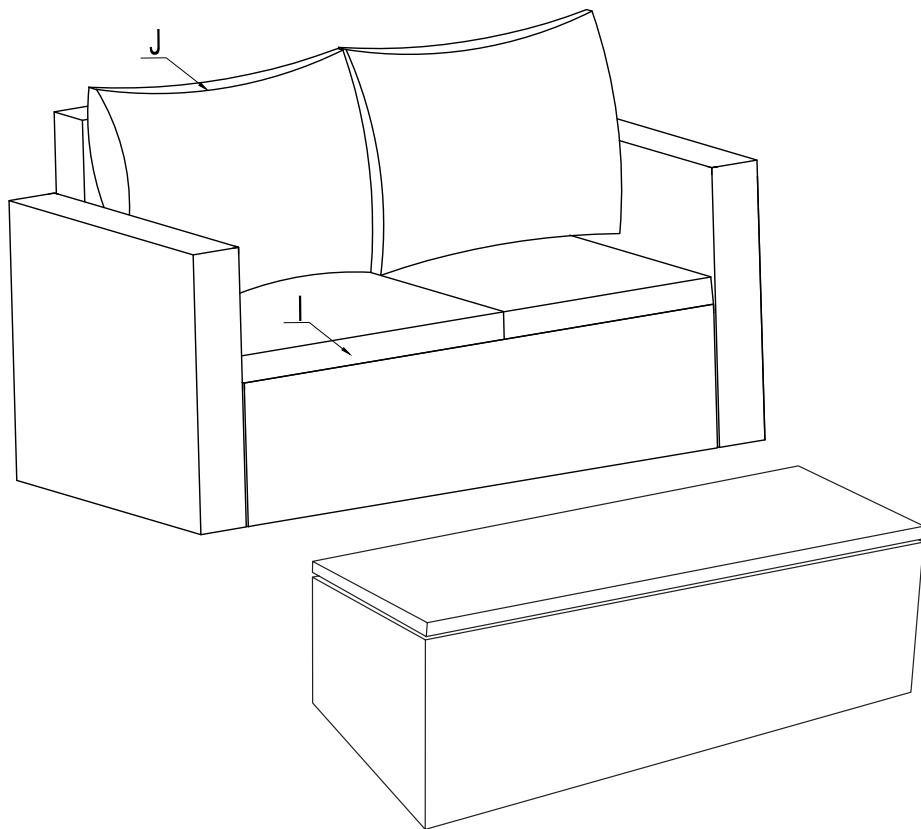

NOW YOU'RE FINISHED!

**THANK YOU FOR
YOUR PURCHASE.**

