

ASSEMBLY GUIDE



Important - Please read these instructions fully before starting assembly



SAFETY AND CARE ADVICE

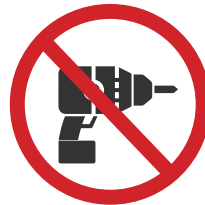

NO POWER TOOLS

SAFETY AND CARE ADVICE

- Check you have all the components and tools listed.
- Remove all fittings from the plastic bags and separate them into their groups.
- We do not recommend the use of power drills/drivers for inserting screws, as this could damage the unit. Only use hand screwdrivers and Allen keys.
- Keep children and animals away from the work area, small parts could cause choking if swallowed.
- Make sure you have enough space to layout the parts before starting.
- Assemble the item as close to its final position (in the same room) as possible.
- Do not overtighten the nuts to avoid causing damage to the threads.
- Only clean using a damp cloth and mild detergent, do not use bleach or abrasive cleaners.
- From time to time check that there are no loose screws on this unit
- This product should not be discarded with household waste. Take to your local authority waste disposal centre

IMPORTANT INFORMATION



30 MINUTE
BUILD















TWO
PERSON



MAXIMUM
CAPACITY 80Kg

PLEASE CHECK CAREFULLY AND MAKE SURE YOU HAVE ALL FITTINGS AND TOOLS LISTED BELOW BEFORE YOU START.

Parts	
①	 Top x1
②	 Frame x1
③	 Leg x1
④	 Base x1
⑤	 Weight (in the Base) X1

Fixings	
A	 $\varnothing 8 \times 25 \text{mm}$ X6PCS
B	 $\varnothing 8 \times 40 \text{mm}$ X8PCS
C	 $\varnothing 10 \times 60 \text{mm}$ X1PCS
D	 8x22mm X14PCS
E	 5mm X1PCS
F	 8mm X1PCS
G	 $\varnothing 10 \text{mm}$ X1PCS

NOTE: Parts 2, 4 and 5 will arrive attached for delivery, please use tool G to unfasten all pieces before assembly.

NOTE: The quantities above are the correct amount to complete the assembly. In some cases more fittings may be supplied than are required.

STEP 1

Use a clean, flat, soft surface to avoid any bumps or scratches.

Attach the frame [2] to the leg [3]. The leg can be attached either way round. Use 1x washer [D] followed by 1x bolts [A] for each hole - 3 in total. Tighten with allen key [E].

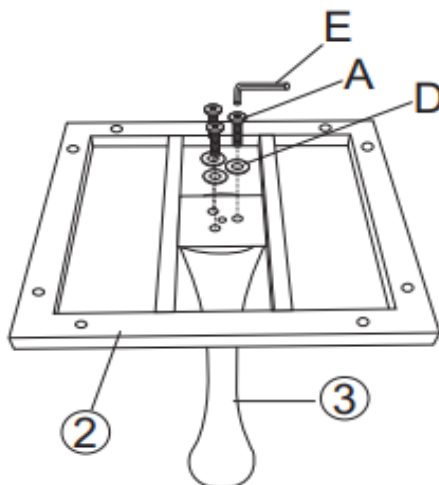

STEP 2

Place tabletop [1] upside down on your flat, soft surface. Carefully, and with help, flip the leg and frame upside down.

Attach the extending frame [2] to the the tabletop using 1x washer [D] followed by 1x bolt [B] for each hole - 8 in total. Tighten with Allen key [E].

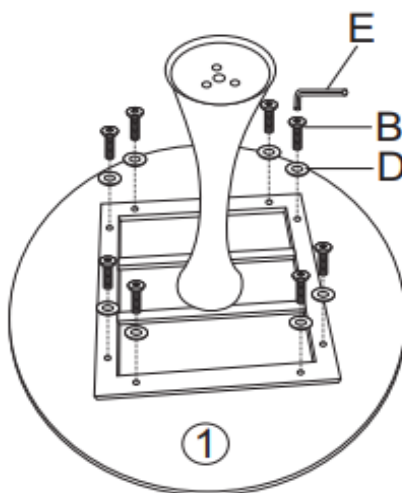

STEP 3

Attach the table base [4] to the table leg using 1x washer [D] followed by 1x bolt [A] for each hole - 3 in total. Tighten with Allen key [E].

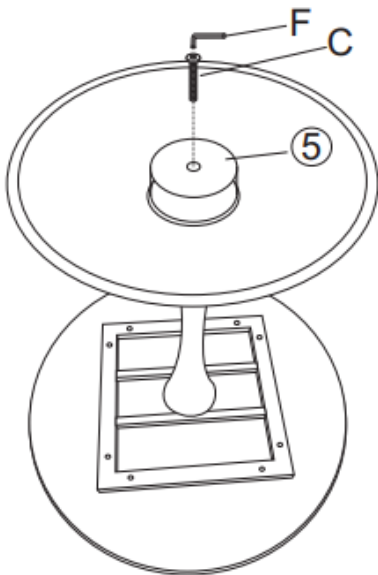
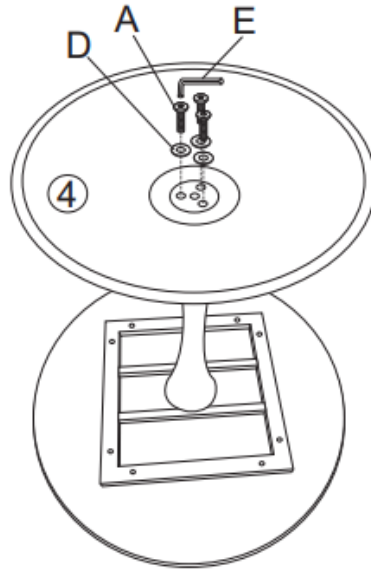

STEP 4

Attach the weight [5] to the bottom of the table base [4] using 1 x long bolt [C]. Tighten with Allen key [F]. **Make sure you ensure this weight is securely tightened, as it's crucial for the stability of the table.**

STEP 5

Carefully and with help, flip your table upright onto its base. Check for stability. Your new table is now ready to use.





OUR 2 YEAR* GUARANTEE

our products come with a 2 year guarantee
to give you peace of mind shopping

*excludes some garden furniture items
which have a 1 year guarantee



WHAT THE GUARANTEE COVERS



PRE-INSERTED FIXINGS

e.g. lose metal threads



FAULTY JOINTS

e.g. legs bending



EXTERNAL FIXING FAULTS

e.g. bonding/glue



STRUCTURAL INTEGRITY

e.g. the frame of the
product