

# INSTRUCTION

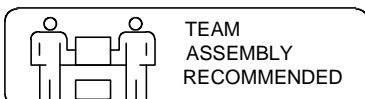

## Arm Chair

**Notice:** As the cushions are vacuum-compressed, allow up to 72 hours for them to return to their original shape. To expedite this process, you may knead the cushions gently, similar to a massage, to facilitate air circulation through the foam. This will enhance the cushions' rebound and help them become fluffy. If there are any wrinkles, use an iron to gently smooth them out.

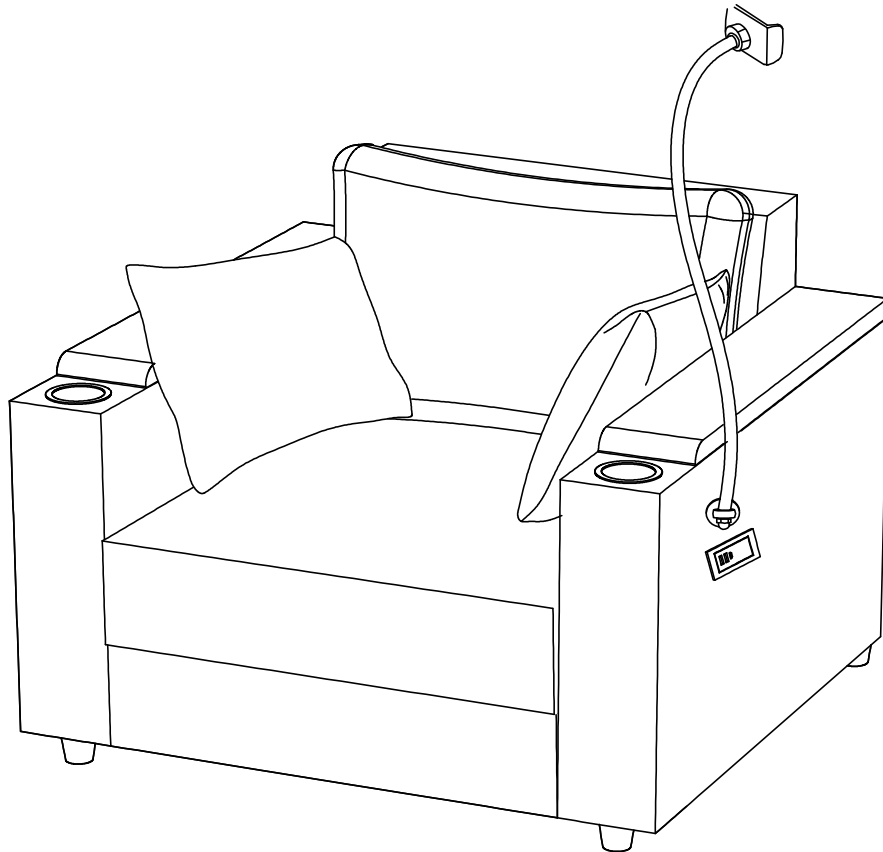

# PARTS LIST

**A** x1

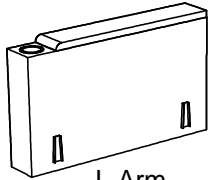

L Arm

**B** x1

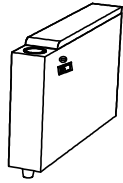

R Arm

**C** x1



Phone Holder

**D** x1

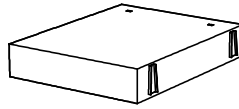

Seat Frame

**E** x1

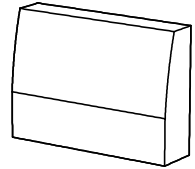

Back

**F** x1

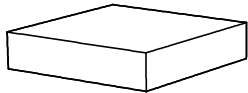

Seat Cushion

**G** x1

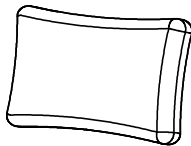

Back Cushion

**H** x2

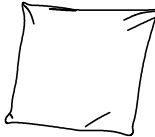

Throw Pillow

**J** x2



Insert

**K** x8



Leg

**L** x1



USB power

## Step1

Ship by 1 box

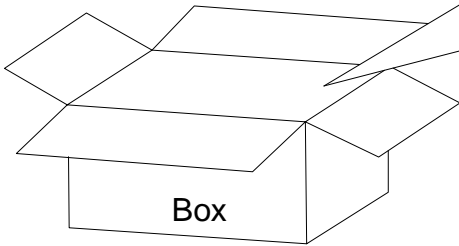

Box

N719P211024

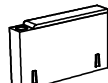

**A** x1



**B** x1



**C** x1



**D** x1



**E** x1

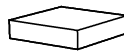

**F** x1



**G** x1



**H** x2



**J** x2



**K** x8



**L** x1

## Step2

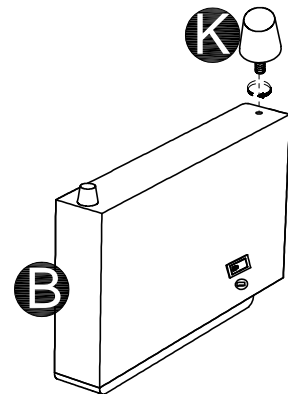
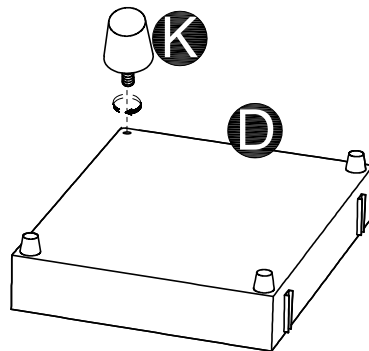
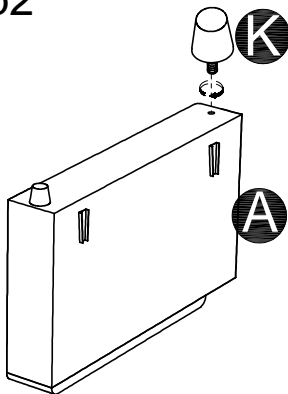

### Step3

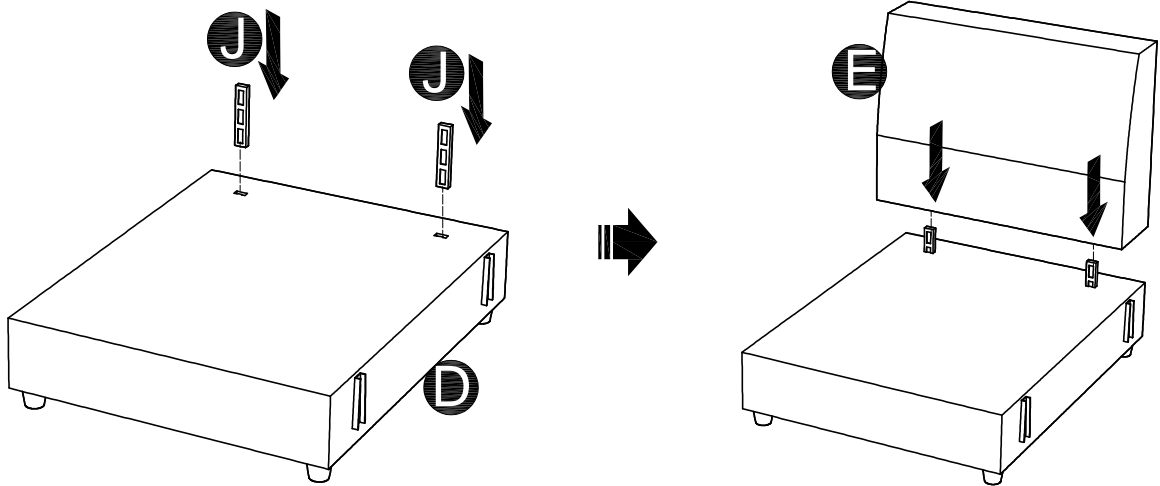

### Step4

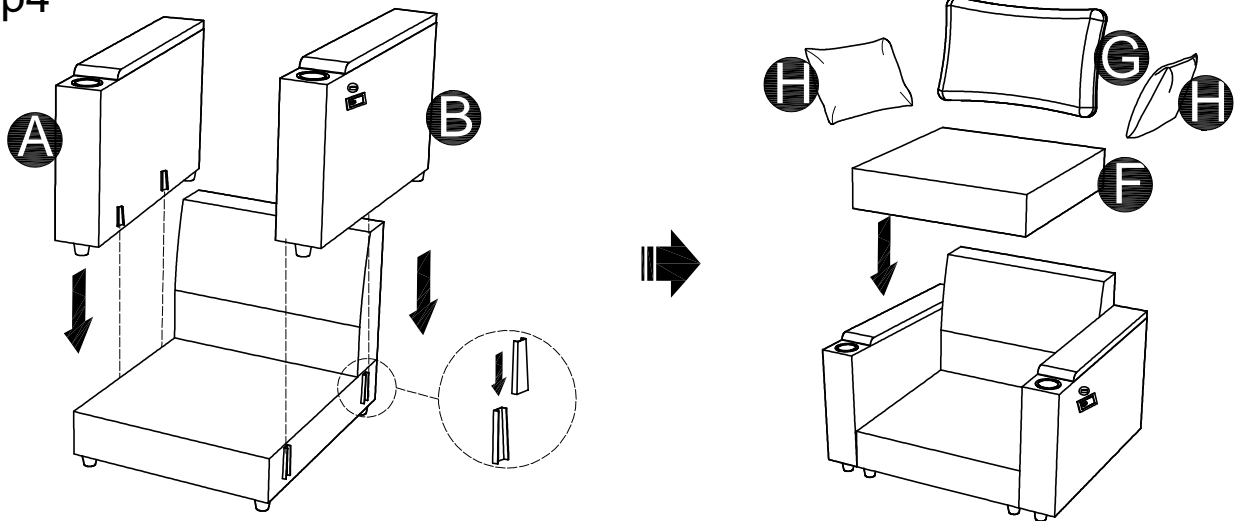

### Step5

