

STEP 5

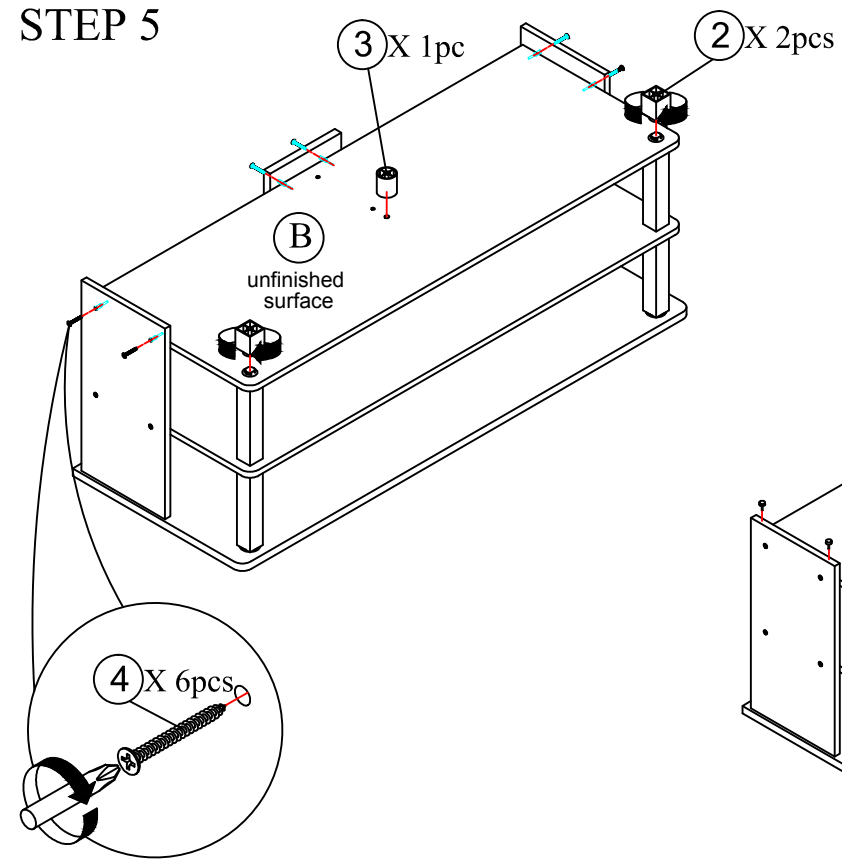

STEP 6

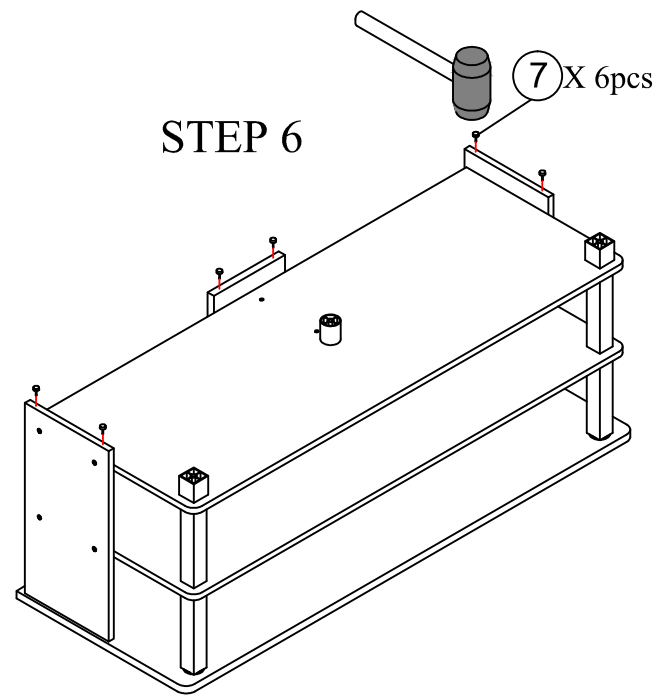

STEP 7

TURN 180°

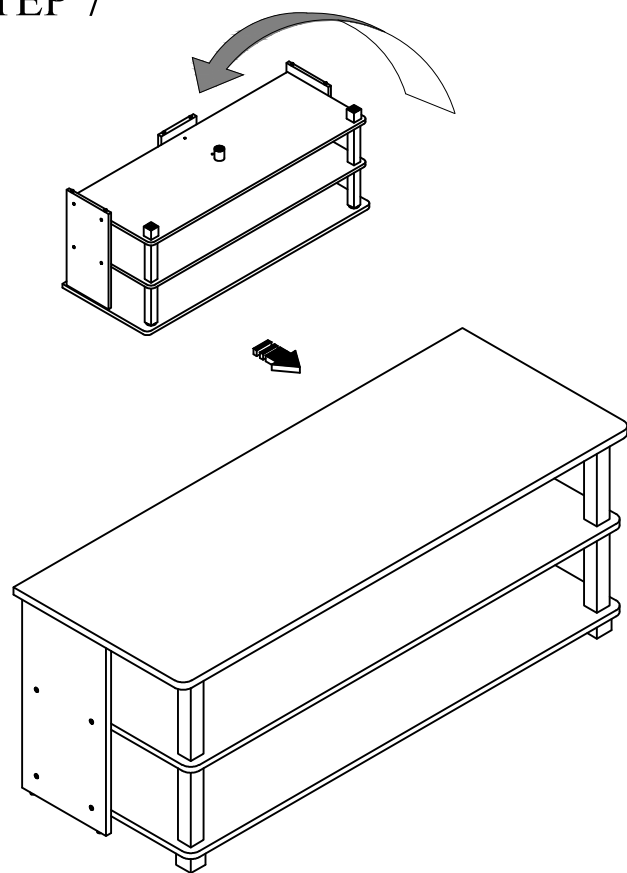

Recommended Maximum Weight

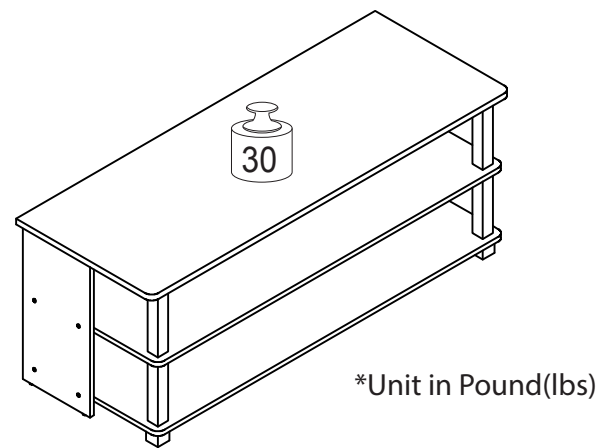

*Unit in Pound(lbs)

WARNING:

- >This unit has been designed to support the maximum loads shown. Exceeding these load limits could cause sagging, instability, product collapse, and/or serious injury.
- >DO NOT allow children to climb on unit.
- >Put heavier items on lower shelves.

Assembly Instruction

00:30

Approx. 30 minutes





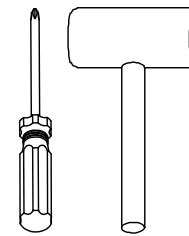



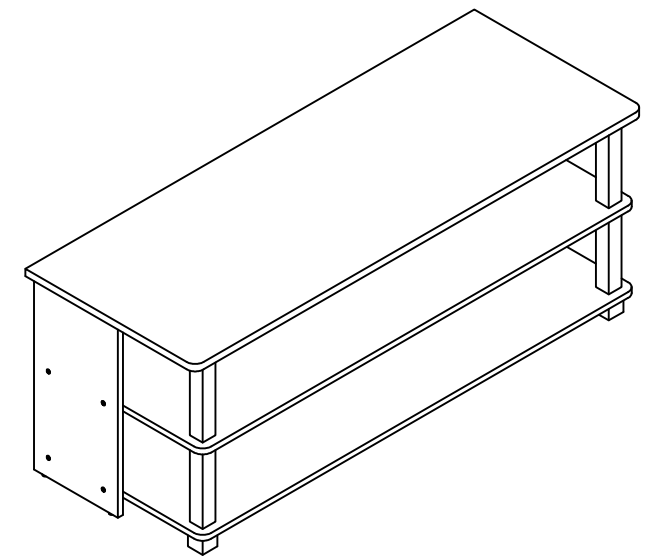

Recomm. 1 Person

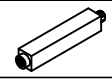

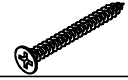
Tools Required



HARDWARE & PARTS LIST

NO	HARDWARE LIST	QTY
1	SHORT POLE 	4pcs
2	LEG 	2pcs
3	PLUG LEG 	1pc
4	SCREW 	12pcs
5	CAM-LOCK SCREW 	8pcs
6	CAM-LOCK NUT 	8pcs
7	NAIL LEG 	6pcs
8	LONG DOWEL 	2pcs
9	SHORT DOWEL 	2pcs

NO	PARTS LIST	QTY
A	TOP PANEL	1pc
B	SHELF / BOTTOM PANEL	2pcs
C	SIDE PANEL	2pcs
D	BACK PANEL	1pc
E	CENTER UPPER PANEL	1pc
F	CENTER BOTTOM PANEL	1pc

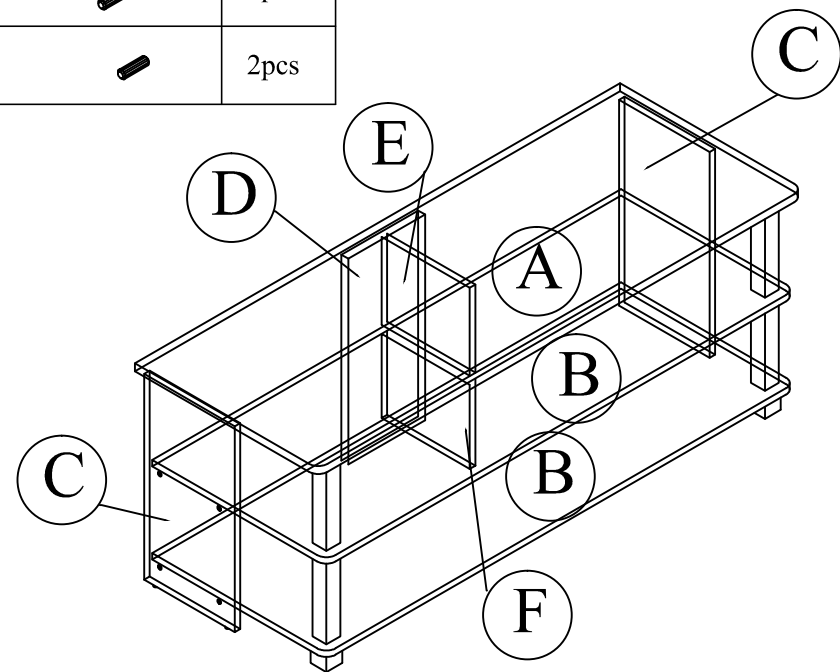

USEFUL HINTS BEFORE YOU START:

1. Read each step carefully before starting.
2. It is important that each step is performed in correct order to avoid difficulties.
3. Identify, sort and count the parts before assembly.
4. Assemble your furniture on packaging cardboard to prevent scratch or damage.
5. Clean the product with mild cleanser using soft damped cloth. Do not use harsh or abrasive cleanser.
6. Using incompatible hardware might cause damage to product.

ASSEMBLY INSTRUCTIONS

BEFORE YOU BEGIN, PLEASE READ ASSEMBLY INSTRUCTION CAREFULLY, FOLLOW THEM STEP BY STEP.

STEP 1

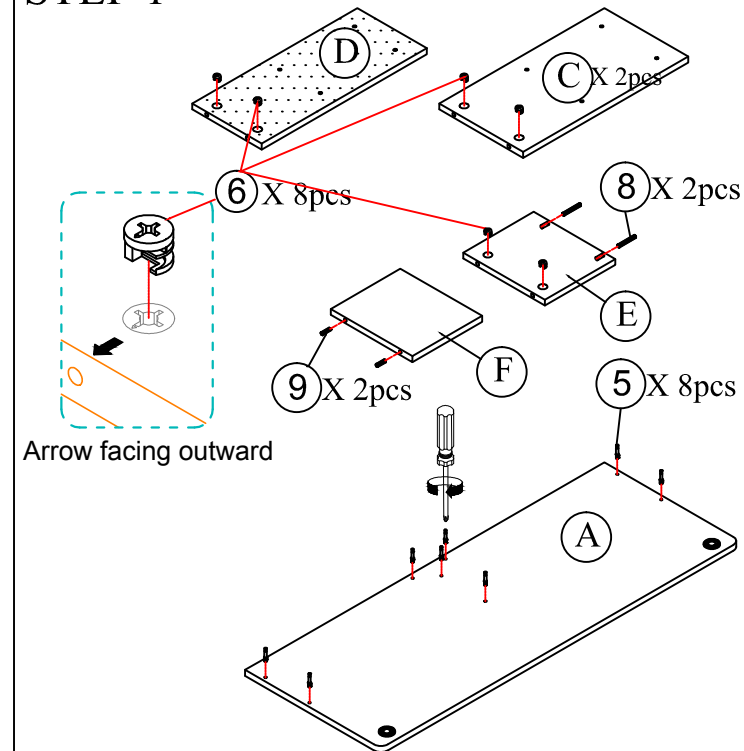

STEP 2

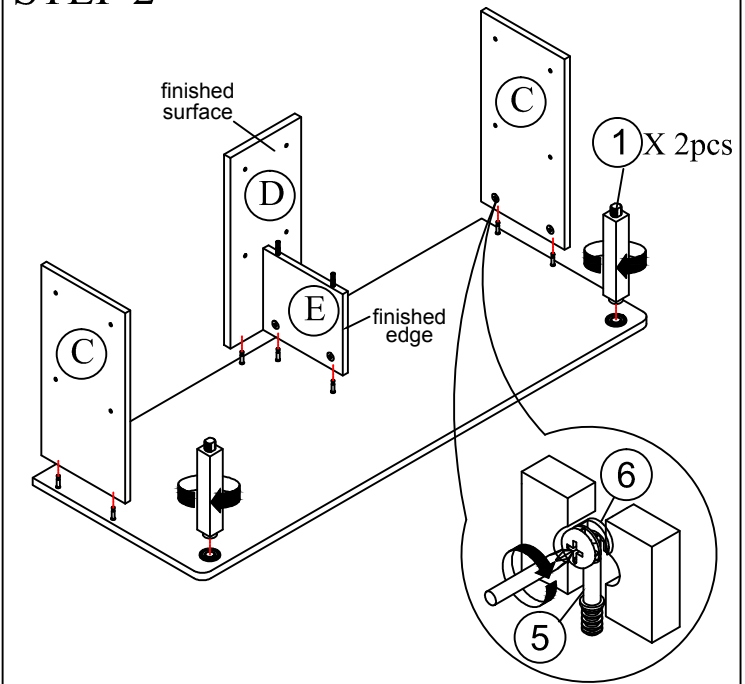

STEP 3

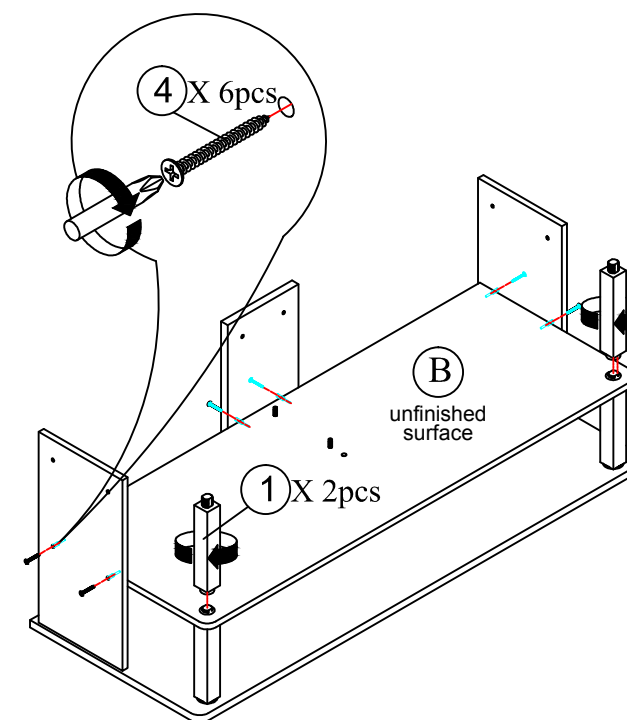

STEP 4

