

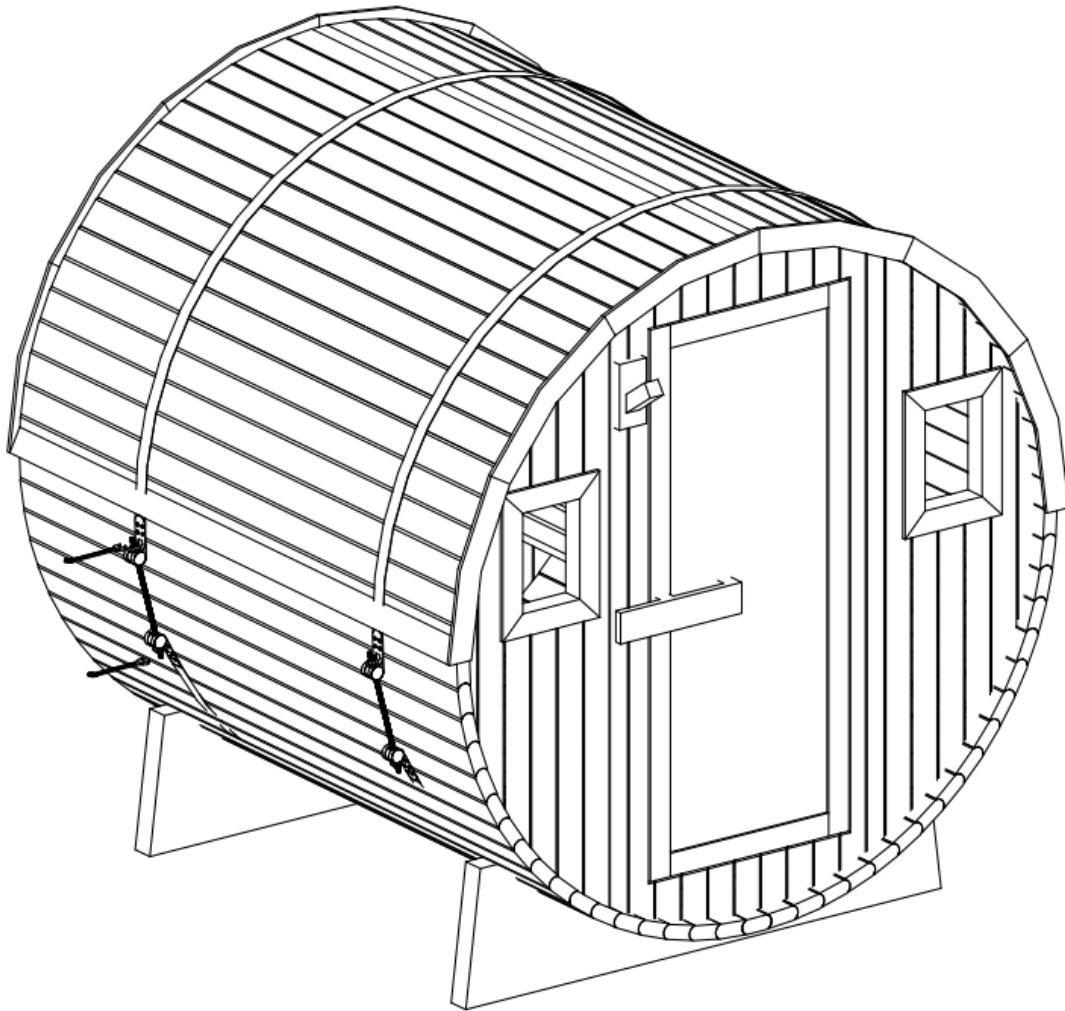

REDWOOD  
OUTDOORS

# Classic 6-Person Barrel Sauna



(Hemlock 95)

Installation & Owner's Manual



# Important Information

## Safety and Assembly

**Please read and understand the complete instructions prior to assembly and use of your sauna.** The customer agrees not to hold Redwood Outdoors or any of its authorized dealers liable for improper installation, maintenance, and repair of this product.

Our sauna kits are designed for ease of assembly and every attempt has been made to make assembly information as clear as possible. If you have any questions about assembly, please do not hesitate to call us at 1800-567-8036 or send us an email at [support@redwoodoutdoors.com](mailto:support@redwoodoutdoors.com).

Thank you again for choosing Redwood Outdoors. We are grateful for your business and know you will have many years of enjoyment in your sauna!

### Electrical Requirements

All electrical heater wiring must be performed by **A QUALIFIED LICENSED ELECTRICIAN**. Use copper wire with 90C insulation. Do not use aluminum wire to make the connection. Consult with an electrician so you can determine the requirements for your situation. All wiring must conform to all national, state, and local codes and regulations. For further information and instructions on your heater installation and operation, please consult the heater manuals on our website. ([www.redwoodoutdoors.com/assembly/electric-sauna-heaters](http://www.redwoodoutdoors.com/assembly/electric-sauna-heaters)).

### Choose a Site With a Strong and Level Foundation

It is important to choose a site that has a level, strong, and stable foundation. This is critical because a sauna with several bathers inside can weigh over 1,000 lbs. A deck or concrete pad (patio) are both excellent options for your sauna. If you will be placing the sauna directly on the ground, we recommend you rest the support cradles atop concrete pavers to prevent the cradles from settling into the ground. This could result in the sauna not sitting level and may cause issues over time. If your sauna comes with a ground-frame rather than cradles, we recommend installing a moisture barrier under the ground-frame.

### Concrete Pads

If constructed properly (compacted well and leveled), a concrete pad will maximize the life of your sauna. The concrete pad should be at least 4" thick and reinforced with mesh to minimize cracking. We recommend constructing the pad significantly larger than needed for the sauna alone, as this will allow room for a cool down area, where you could put chairs and an outdoor shower or cold plunge tub. There is a wealth of information available online with instructions on how to design and pour a concrete pad.

### Deck Installations

If you choose to install your sauna on a deck, be sure that your deck has been designed to support the weight of a full sauna (over 1,000 lbs). We recommend you have the deck inspected by a qualified architect or building engineer prior to proceeding.



REDWOOD  
OUTDOORS

# Installation & Owner's Manual

# CONTENTS

---





|                               |    |
|-------------------------------|----|
| Parts List                    | 02 |
| Dimensions                    | 04 |
| Base Assembly                 | 05 |
| Wall Assembly                 | 06 |
| Body Assembly                 | 08 |
| Interior Assembly             | 11 |
| Interior & Exterior Finishing | 12 |
| Heater Installation           | 14 |
| Shingle Installation          | 16 |
| Maintenance                   | 18 |
| Warranty                      | 20 |
| User Guide                    | 21 |
| Important Notice              | 23 |

# Parts List



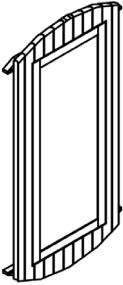
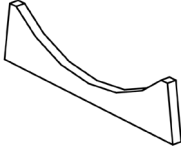
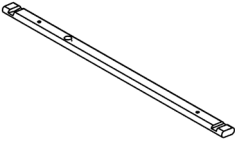
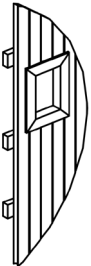
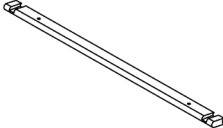
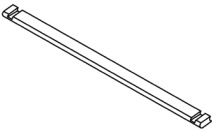
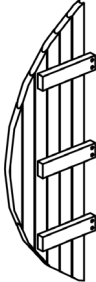
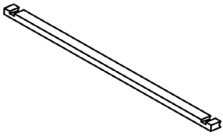
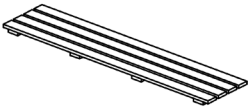
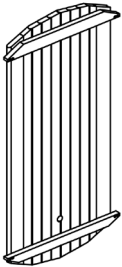

We are constantly working to improve our products. As a result of ongoing design improvement, the sauna you receive may vary slightly from the description below. + symbol indicates spare pieces. (e.g. +1 means 1 spare)

When you open the crate, if any parts are damaged, take pictures of the damage (ideally while still in the crate). Email the pictures as well as a list of which parts are damaged (e.g., 2-B, 18, etc.) to our Customer Support team (support@redwoodoutdoors.com). Our Customer Service team will assist you with next steps.



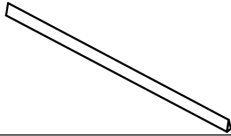

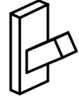
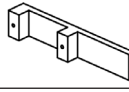
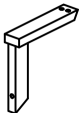
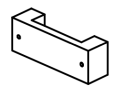







## ● Main Parts

| Part | Description   | Qty | Part | Description   | Qty     |
|------|---|-----|------|---|---------|
| 1    |    | 1PC | 6    |                | 1PC     |
| 2-A  |   | 1PC | 7    |               | 2PCS    |
|      |   |     | 8    |              | 1PC     |
| 3    |  | 1PC | 9    |              | 14PCS   |
|      |   |     | 10   |              | 48PCS+2 |
| 4    |  | 1PC | 11   |              | 2PCS    |
|      |   |     | 12   |              | 2PCS    |
| 5    |  | 1PC | 13   |  <b>THICK</b> | 1PC     |
|      |   |     | 14   |  <b>THIN</b>  | 1PC     |

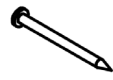

| Part | Description   | Qty  | Part | Description   | Qty   |
|------|---|------|------|---|-------|
| 15   |  | 2PCS | 18   |  | 12PCS |
| 16   |  | 1PC  | 19   |  | 1PC   |
| 17   |  | 2PCS | 20   |  | 1PC   |
|      |   |      | 21   |  | 2PCS  |

● Accessories

| Part | Description  | Qty     | Part | Description   | Qty   |
|------|--|---------|------|---|-------|
| A    |  #8x $\frac{3}{4}$ "<br>(4x20mm)  | 50PCS   | H    |  | 4PCS  |
| B    |  #8x1"<br>(4x25mm)                | 24PCS+6 | I    |  | 4PCS  |
| C    |  #8x1 $\frac{1}{2}$ "<br>(4x40mm) | 20PCS   | J    |  | 4PCS  |
| D    |  #8x2 $\frac{1}{2}$ "<br>(4x60mm) | 84PCS+6 | K    |  | 50PCS |
| E    |  #12x3"<br>(6x80mm)               | 2PCS    | L    |  | 1PC   |
| F    |                                   | 2PCS    | M    |  | 2BAGS |
| G    |                                   | 2PCS    |      |   |       |

# Dimensions

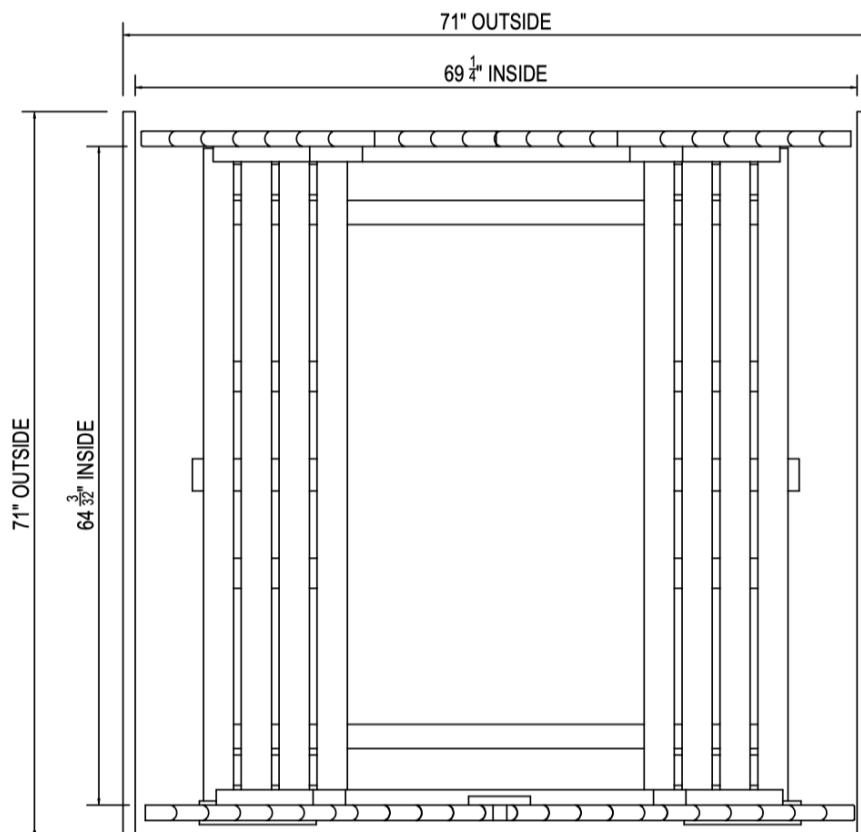
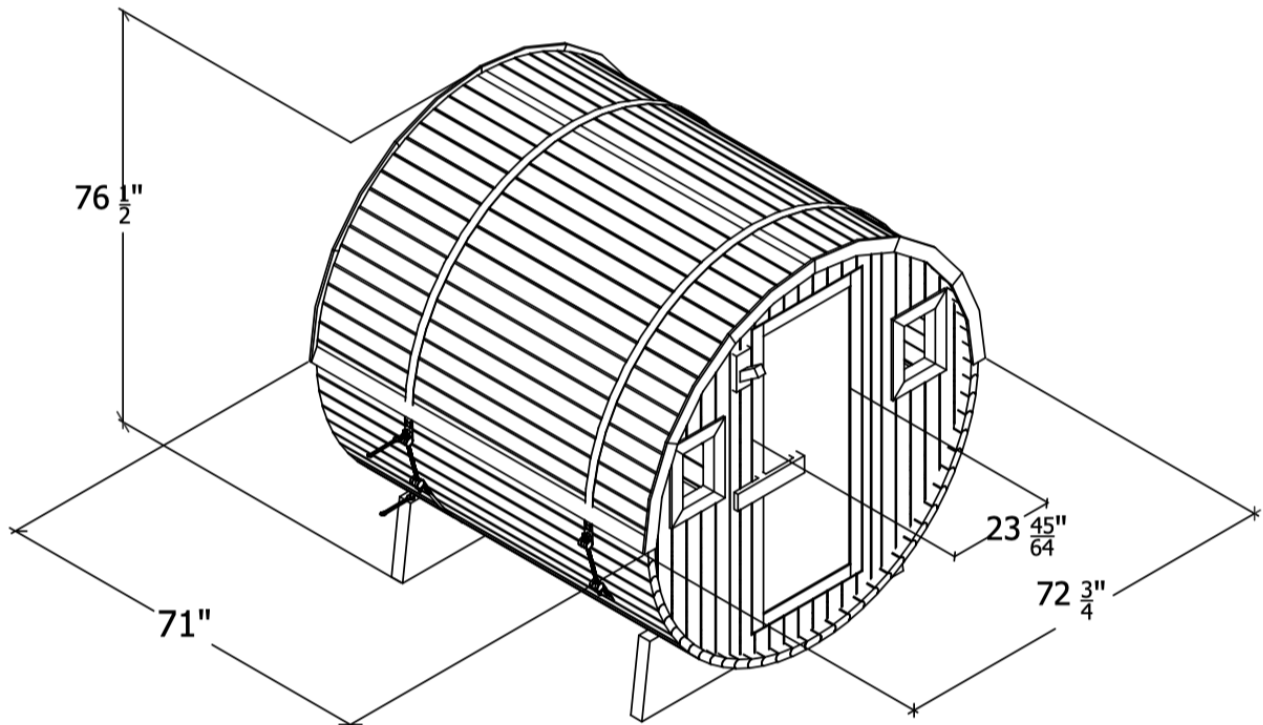

# Base Assembly

## Step 1: Assemble the Base



Lay your cradles on the foundation. The wooden cradles are painted black to provide additional protection against water.

Ensure the cradles are level. The cradles must be evenly spaced and parallel. Make sure the cradles are parallel by measuring from corner to corner.

Lay the drain stave across the center point of the cradles. The drain hole will be at the back of your sauna. The end of the stave should extend  $8\frac{3}{4}$ " past the cradles on both edges (the cradles should align with the staves' pre-drilled holes). Ensure your cradle does not block the drain hole. Fasten the drain stave to the cradles.

**Unpack all staves from the crate before starting. The #9 staves have predrilled holes** to make fastening to the cradles easier. The #9 staves may be at the bottom of your crate. Ensure you locate and use these staves (otherwise they will end up on your roof!).

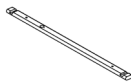
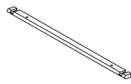
Fill the cradles to the edge with staves. As you lay the staves, tap them into place using a rubber mallet to ensure a snug fit. Ensure the groove cut for the front and back walls ("dado cut") aligns and that the ends of the staves are flush. Fasten the rest of the base staves to the cradles.

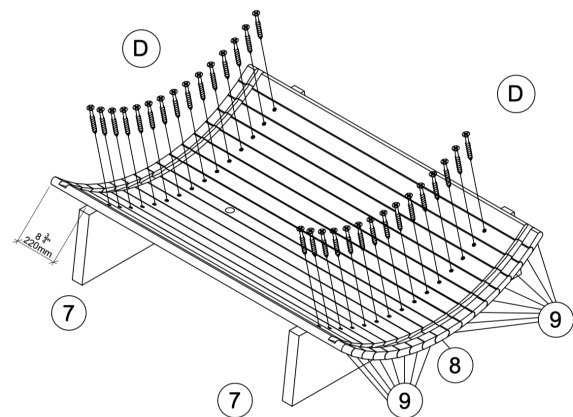

| 7   | 8  | 9   | D  |
|---|--|---|--|
|  |  |  | <br>#8x2 1/2"<br>(4x60mm) |



# Wall Assembly

## Step 2: Assemble the Front Wall

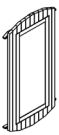

The front wall is divided into three pieces. Lay the three pieces out on a flat surface and fasten the three pieces together. Ensure that the edges of the wall are flush and form a circle.

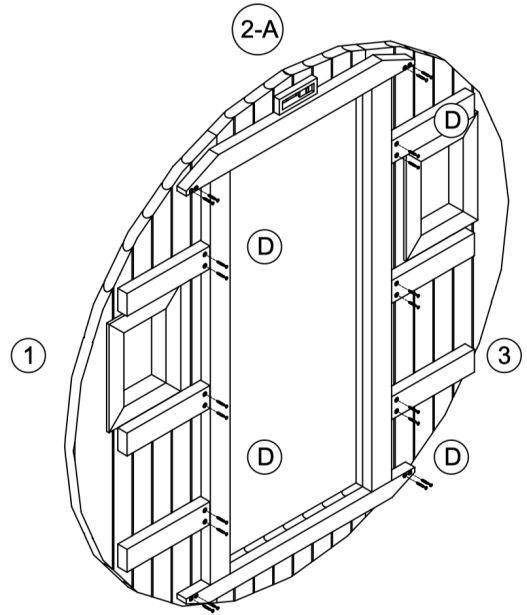
| 1   | 2-A   | 3   | D   |
|---|---|---|---|
|  |  |  | <br>#8x2 $\frac{1}{2}$ "<br>(4x60mm) |

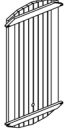
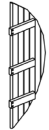

### Step 3: Assemble the Back Wall

The back wall is divided into three pieces. Lay the three pieces out on a flat surface and fasten the three pieces together. Ensure that the edges of the wall are flush and form a circle.

| 4   | 5   | 6   | D   |
|---|---|---|---|
|  |  |  | <br>#8x2½"<br>(4x60mm) |

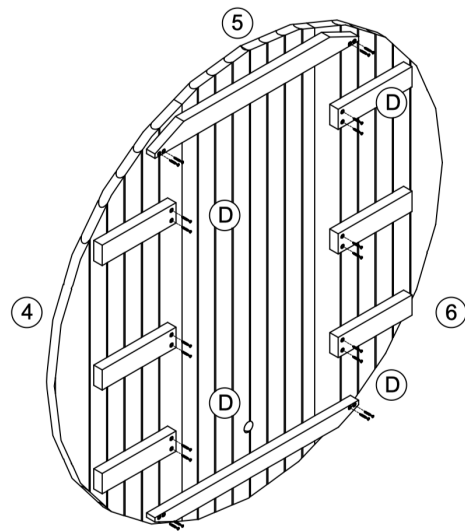

### Step 4: Place the Walls on the Base

Fit the front and back walls into the front and back dado cuts as shown in the picture. Use a level to confirm that the walls are level with the ground.

The horizontal support bars (“cleats”) should be facing inside the barrel. These cleats are used to support the benches.

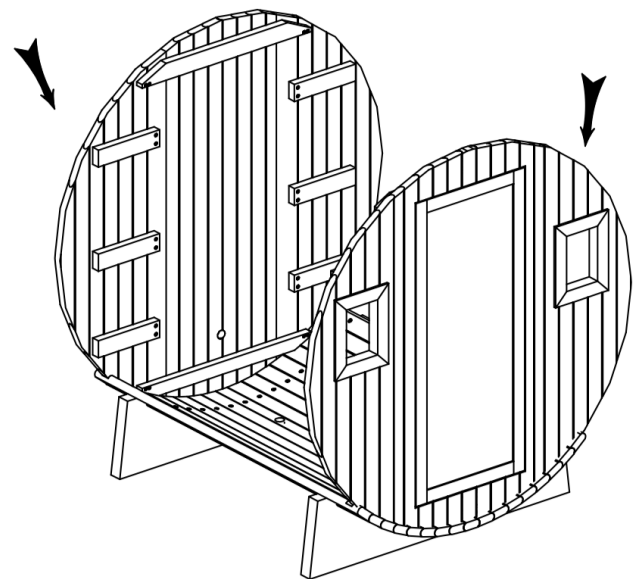





# Body Assembly

## Step 5: Install the Front Door Handle

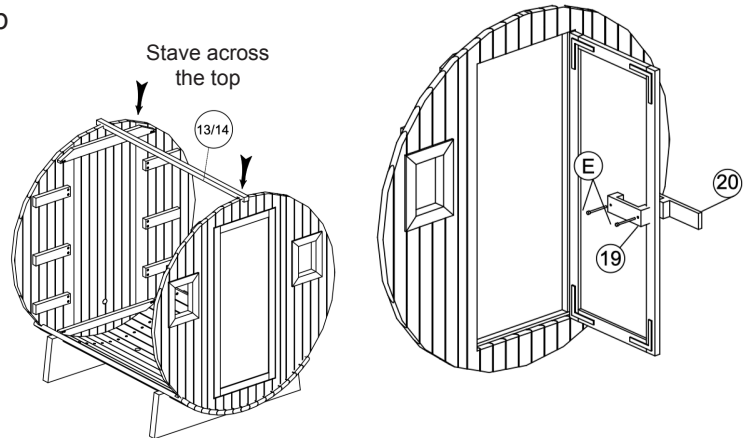
We recommend placing a stave across the top of the walls to prevent movement as you build up the side walls.

Place the door handle pieces on either side of the glass door. The pieces should align with the pre-cut holes in the glass door. Fasten the two pieces together (the screw should pass through the glass door to prevent the handles from moving).

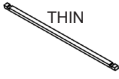
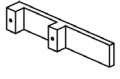
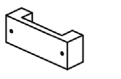

|   |  |   |   |  |
|---|--|---|---|--|
| 13  | 14   | 19  | 20  | E  |
|  THICK |  THIN |  |  | <br>#12x3"<br>6x80mm) |

## Step 6: Install the Remaining Staves



Build up the staves on both sides of the wall. Use the nails provided to fasten every stave or every second stave to the wall while installing (this is to prevent staves from falling out of position).

As you install each stave, tap it into place using a rubber mallet to ensure a snug fit.

Once the halfway point is reached, the staves can be fastened less frequently as gravity will keep them in place, however, continue to tap them into place using a rubber mallet.

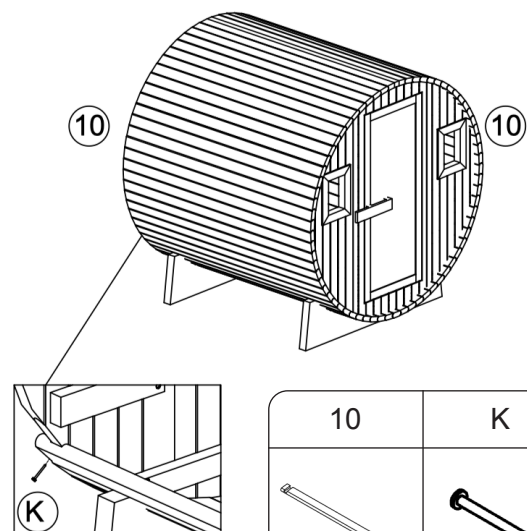
Handle the staves with care. The wood is kiln-dried and brittle. If staves are dropped or mishandled, they can crack or even break.

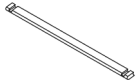

|   |   |
|---|---|
| 10  | K   |
|  |  |

## Step 7: Complete the Stave Installation

The final staves installed are the two top staves, followed by a spacer stave. The flat sides should face each other at approximately the top center of the sauna.

A very small gap between the two center staves is normal. If your gap is larger than ¼", it's best to add one of the spacer staves (stave with double flat edges). We provide both a thick and a thin spacer stave to provide you with options at the top. Because wood can expand and shrink depending on its moisture content, every build is a little bit different. On most builds it should be possible to insert one of the spacer staves.

If the spacer staves are not needed, store them as they may be needed later. Over time the wood can dry and shrink slightly, so the spacer staves can be used to close any gaps that may appear in the future.

After a spacer stave is added, the fit at the top will be tight and possibly force the staves at the top of the sauna upwards to look peaked. **Having peaked staves at the top of the sauna is completely normal at this stage.** You will round out the sauna with a mallet and ratchet strap in the next step.

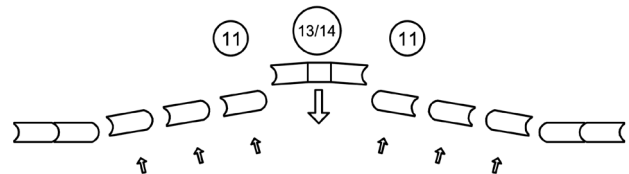
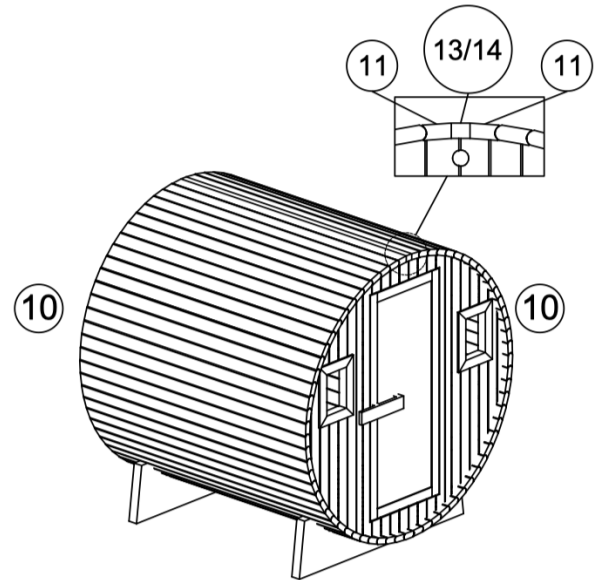

\*Bumping the staves nearest to the center outwards will increase the diameter of your sauna. This will give you extra space to insert the final stave or spacer

| 10 | 11 | 13 | 14 |
|----|----|----|----|
|    |    |    |    |





# Body Assembly

## Step 8: Install the Bands

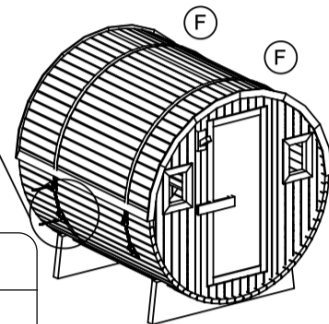
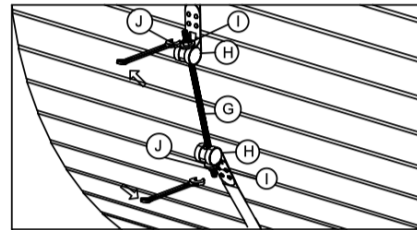
The purpose of the bands is to lock the staves in place. However, the bands and threaded rods are not the most effective tools for cinching in the staves during assembly. We strongly recommend using a ratchet strap (not provided) to cinch the staves in when rounding the barrel. Then take the slack out of the bands to lock the staves in position. Using the ratchet strap and bands in combination is the best method to avoid stripping the rods. You can put a towel behind the ratchet strap handle to prevent marking the wood.

Install the bands at the edges of the sauna close to the cradles as shown. Use the band hardware.



| F   | G   | H   | I   | J  |
|---|---|---|---|--|
|  |  |  |  |  |

### Tightening the Bands

It is best to use a ratchet strap (not provided) to cinch in the staves. If you do not have a long enough ratchet strap, you can tie two straps together. Start tightening the ratchet strap a little bit at a time. If there are two people assembling, one can tighten the ratchet strap while the other bumps the staves into place with a rubber mallet. The goal is to even out peaks or dips and have the barrel form a perfect circle. It may be necessary to bump upwards from inside the sauna to achieve a circular shape.

To remove all slack from the steel bands, you will need to pound out any kinks or bends in the bands as you tighten them. Aim to hit on the bands themselves as much as possible to avoid accidentally damaging the staves.

Continue alternating between tightening the ratchet strap and the bands until the bands are fully tightened and the barrel forms a circle and there are no gaps between staves.

**If you have difficulty opening the sauna door, you may have over-tightened the bands. Loosen the bands to release some tension.**



After you have used your sauna for approximately 1 month, retighten the bands. The sauna will settle during use and can change shape if the bands are not kept tight.

The bands then should be retightened every ~6 months. Wood is a natural product that shrinks over time, if the bands are not kept tight the sauna can change shape.

# Interior Assembly

## Step 9: Install the Bench Struts

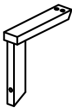
Place the bench struts at the halfway point of the sauna. Use a spirit level to confirm it is level with the wall cleats on either side of the sauna. Fasten the struts to the sauna body.

|   |   |
|---|---|
| 17  | D   |
|  |  |
|   | #8x2 1/2"<br>(4x60mm)   |

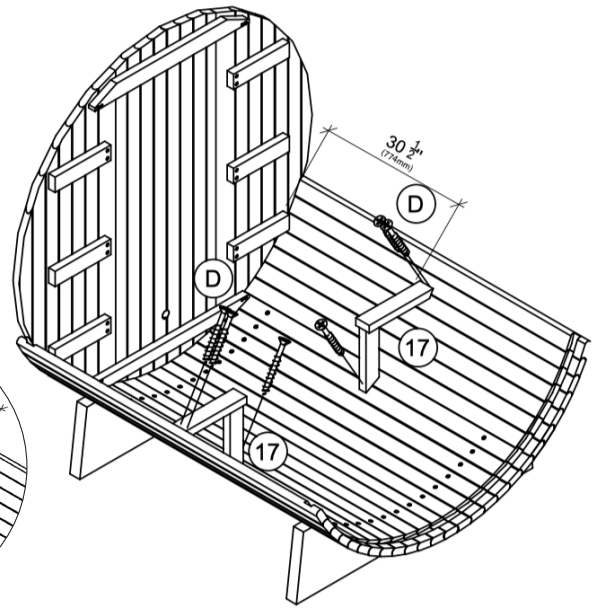
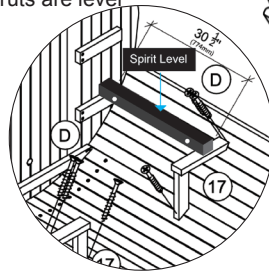

\*How to check if struts are level



## Step 10: Install the Bench Tops

Place the bench tops inside the sauna so that they sit on the wall cleats at either end and the bench struts in the middle. If the bench does not sit level, you may need to adjust the position of the bench support.

Once the bench sits level, fasten the bench top to the bench struts and wall cleats as shown.

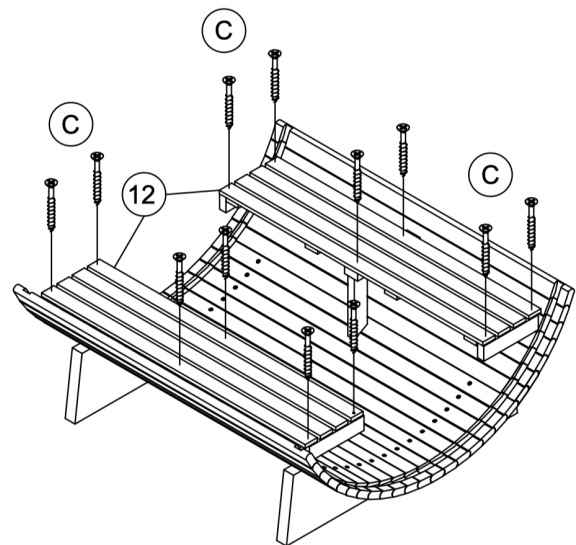

|   |   |
|---|---|
| 12  | C   |
|  |  |
|   | #8x1 1/2"<br>(4x40mm)   |



## Interior & Exterior Finishing

### Step 11: Install the Backrests

Fasten the backrests to the walls of the sauna. The height of the backrests can be adjusted based on your personal preference.

|   |   |
|---|---|
| 21  | D   |
|  |  |
|   | #8x2 1/2"<br>(4x60mm)   |

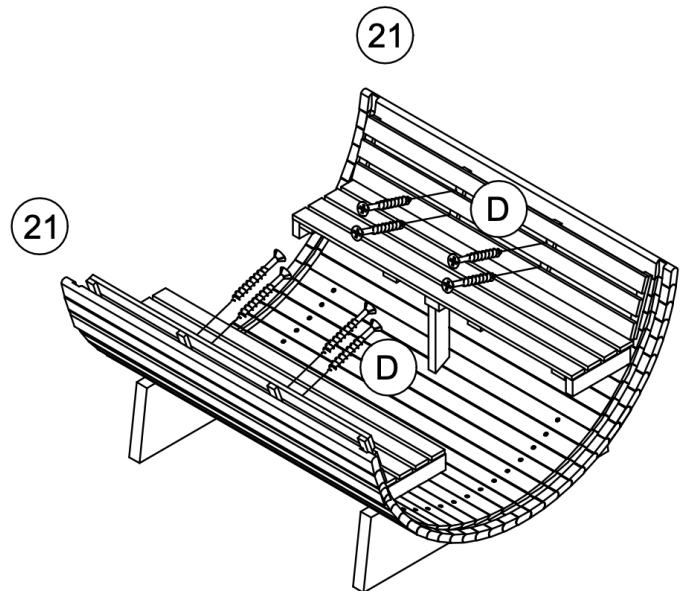



### Step 12: Install the Gables

The wooden gables sit on the front and back walls of the sauna.

Fix the wooden gables to the edge of the staves using screws provided. Six gables should be installed on either end of the barrel.

If not installing the roof tiles, the gables can be left out depending on your aesthetic preference.

|   |   |
|---|---|
| 18  | B   |
|  |  |
|   | #8x1"<br>(4x25mm)   |

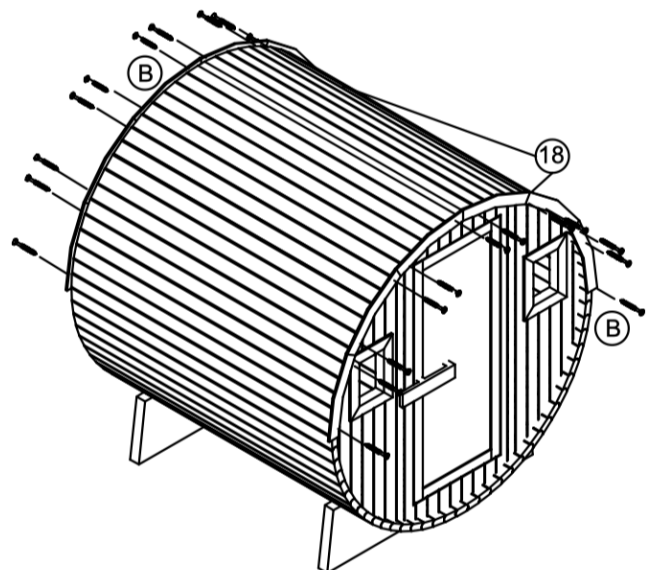

## Step 13: Install the Towel Peg

The sauna includes a towel peg. The towel peg can be placed on the inside or outside of the sauna according to your preference. One suggested location is shown in the picture; however, feel free to place it where it will be most useful for you.

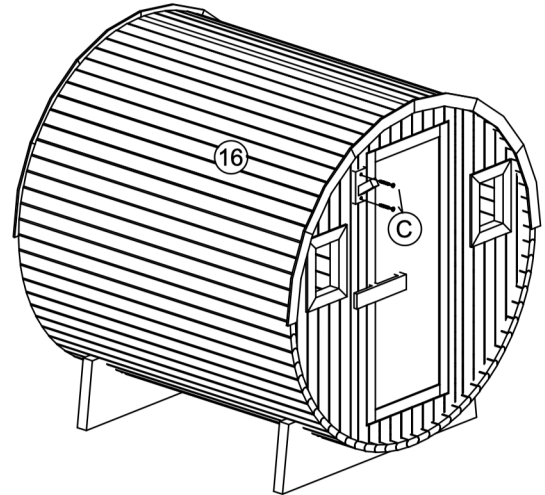
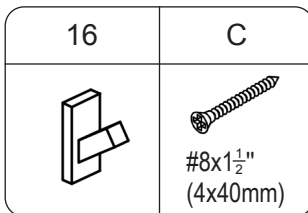

## Step 14: Install the Light Fixture

A light fixture is provided with your sauna.

The light may be installed anywhere inside or outside of the sauna, as long as it is at least 4ft away from the heater and not installed directly above the heater.

The light fixture must be installed by a licensed electrician. Wiring for the light fixture is not provided and will need to be sourced locally.

The light must be wired to a separate **120v** line.

If you have a wifi-enabled heater, the light can be wired into the wifi kit's power box and will be controlled by the included control panel or through your mobile app. More information on this will be available in your heater's manual.

**If your heater is not wifi-enabled, your electrician will need to supply a separate switch for the light as well.**

Your electrician should determine the best way for the wiring to enter the sauna based on your site conditions and fixture placement. Consult with your electrician about how best to hide the wiring for the light.

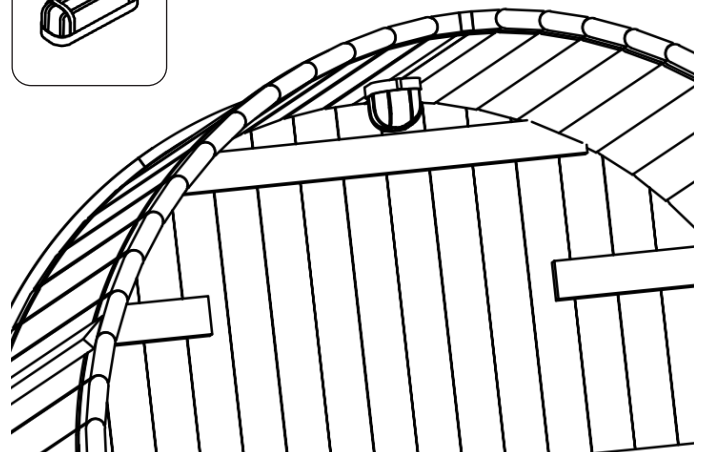
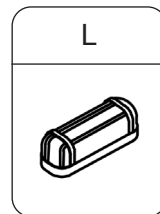

# Heater Installation

## Step 15a: Mount the Heater and Place the Temperature Sensor – Harvia Spirit Heaters

All electrical wiring must be performed by **A QUALIFIED LICENSED ELECTRICIAN**. Heater installation manuals are available on the Redwood Outdoors website and should be provided to your electrician before installation.

Once the heater is installed, place the heater's temperature sensor. The temperature sensor controls the temperature inside the sauna. The heater will shut off when it senses that the sauna has reached the set temperature.

For **Harvia Spirit** heaters, the mounting plate can be mounted so that the bottom sits approximately 12" off of the floor. Use the mounting hardware to secure the mounting plate to the wall of the sauna.

We recommend placing the thermometer approximately **~14" to the side of the heater, and approximately ~4" below the highest point of the sauna**. Please note that the roof is sloped, and the highest point is along the front wall where the slope is at its highest angle.

**Correct temperature sensor placement is crucial to the performance and maintenance of your heater.** If the sensor is placed too high or too low, your heater's internal safety switch will engage and shut off the heater before the 60 minute preheat time is finished, and your sauna may not come to temp. Incorrect temp sensor placement can also negatively affect the lifespan of your heater coils.

*\*If you have any questions about temp sensor placement, please contact Redwood Outdoors Customer Support for assistance.*

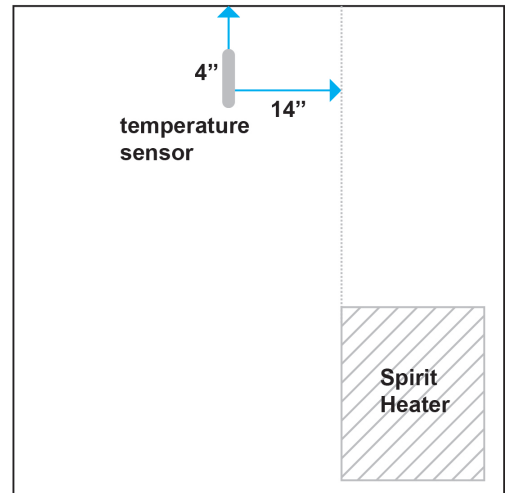

Spirit Heater Temperature Sensor Recommended Placement

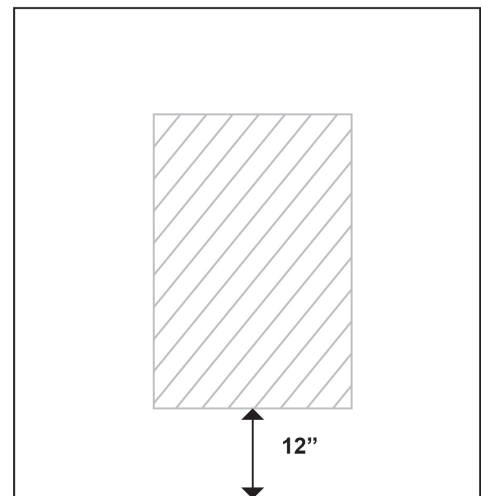

Spirit Mounting Plate Placement

Complete heater manuals are available here



## Step 15b: Mount the Heater and Place the Temperature Sensor – Harvia KIP Heaters

**For KIP heaters**, position the heater mounting screws approximately **20” off the sauna floor and spaced 15 ¼” apart**. Hang the heater on the mounting screws to ensure it is level and that its base sits **5-7” off the floor**.

All electrical wiring must be performed by **A QUALIFIED LICENSED ELECTRICIAN**. Heater installation manuals are available on the Redwood Outdoors website and should be provided to your electrician before installation.

Once the heater is installed, place the heater’s temperature sensor. The temperature sensor controls the temperature inside the sauna. The heater will shut off when it senses that the sauna has reached the set temperature.

For **Harvia KIP** heaters, we recommend placing the thermometer **~14” to the side of the heater and ~14” below the ceiling’s highest point**. Make sure the top of the sensor is not covered. The diagram to the right shows the recommended placement.

**Correct temperature sensor placement is crucial to the performance and maintenance of your heater.** If the sensor is placed too high or too low, your heater’s internal safety switch will engage and shut off the heater before the 60 minute preheat time is finished, and your sauna will not come to temp. Incorrect temperature sensor placement can also negatively affect the lifespan of your heater coils.

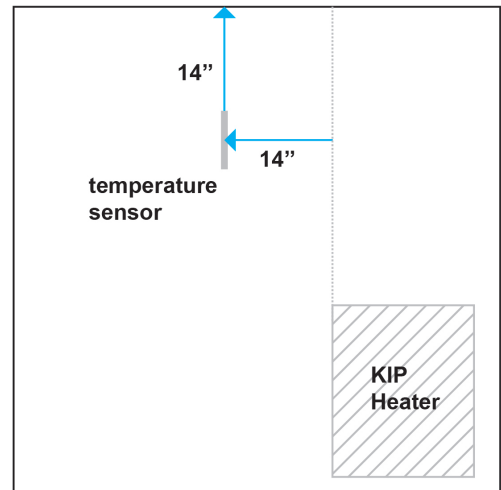

KIP Heater Temperature Sensor Recommended Placement

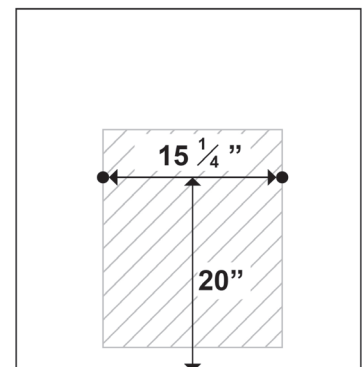



KIP Mounting Screw Placement

# Shingle Installation

## Step 16: Install the Triangular Wood Strip

Roofing underlay is not required; however, it can be added if you'd like an extra layer of protection. Underlay is not provided and must be sourced locally.

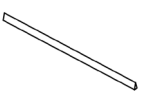
Place the triangular strip at the approximate mid point of the sauna. The triangular strip should angle away from the sauna so that water flows from the shingles off the sauna. This will be the lowest point on your sauna's shingles.

|  |  |
|--|--|
| 15   | C  |
|  |  |
|  | #8x1 $\frac{1}{2}$ "<br>(4x40mm)   |

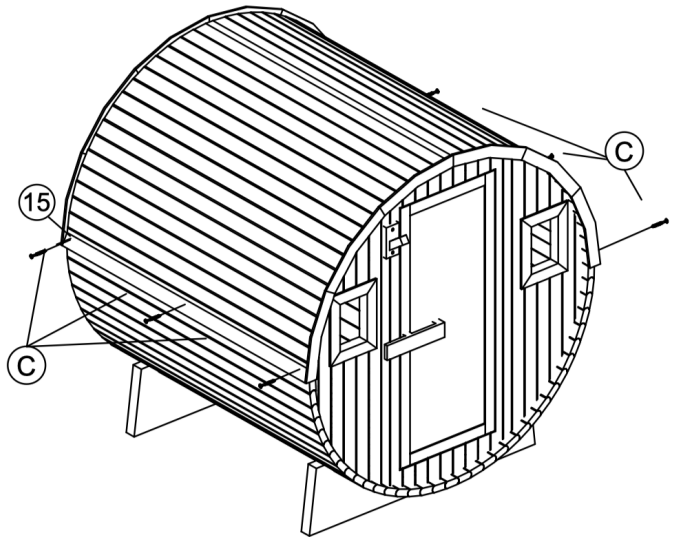



## Step 17: Install the First Row of Shingles

Use a knife or scissors to cut the tiles so the first row has a straight edge on both sides. There is a backing layer on the shingle strips. Peel off this backing layer before placing the shingles on the sauna.

You may need to cut the shingle strips short at the end so that the shingles match and fully cover the roof of the sauna.

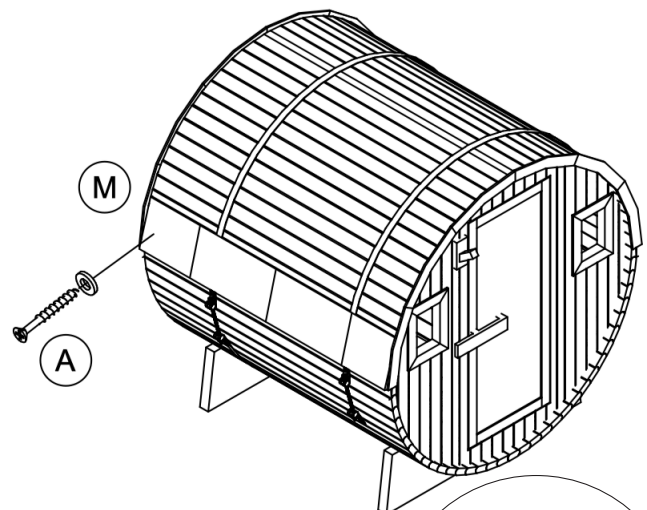
Attach the first row of shingles to the triangular wood strip you attached in the previous step. We recommend using a nail gun with 1" roofer's nails as this will be the fastest assembly method. We provide screws + washers that can be used if you do not have a nail gun. Make sure the washer is used to prevent leaks.



|   |  |
|---|--|
| A   | M  |
|  |  |
| #8x $\frac{3}{4}$ "<br>(4x20mm)   |  |

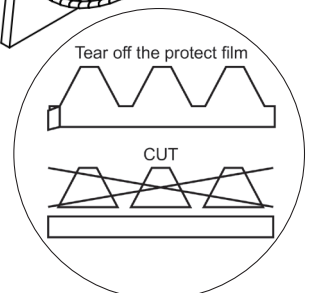



## Step 18: Build Up the Shingle Rows

Work up both sides of the sauna in a zigzag pattern until you meet at the peak. Use at least 3 nails or screws per strip. Fasten at the top of the strip so the next strip will cover the nail or screw heads.

There is a backing film on the shingle strips. Peel off this backing layer before placing the shingles on the sauna.

**Cutting is required.** You must cut the shingle strips short at the ends to maintain the honeycomb pattern.

| A  | M   |
|--|---|
| <br>#8x $\frac{3}{4}$ "<br>(4x20mm) |  |

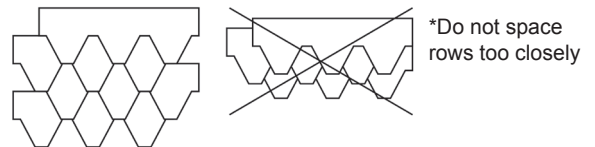
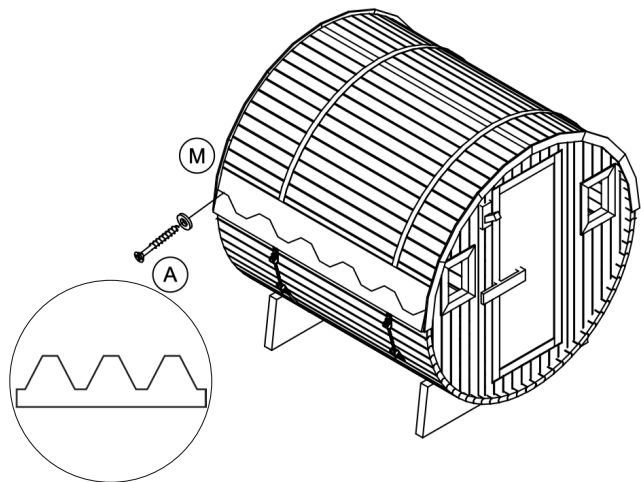

## Step 19: Install the Final Row of Shingles

Once you have covered both sides of the sauna, you will have a seam at the top where the flat ends of the shingle strips meet.

To cover this seam cut the diamond end tiles off 2-3 more shingle strips (creating rectangular pieces) and lay them across the top of the roof. Secure the rectangular strips on the top of the sauna with nails/screws so that there is no exposed wood showing.

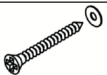
| A  |
|--|
| <br>#8x $\frac{3}{4}$ "<br>(4x20mm) |

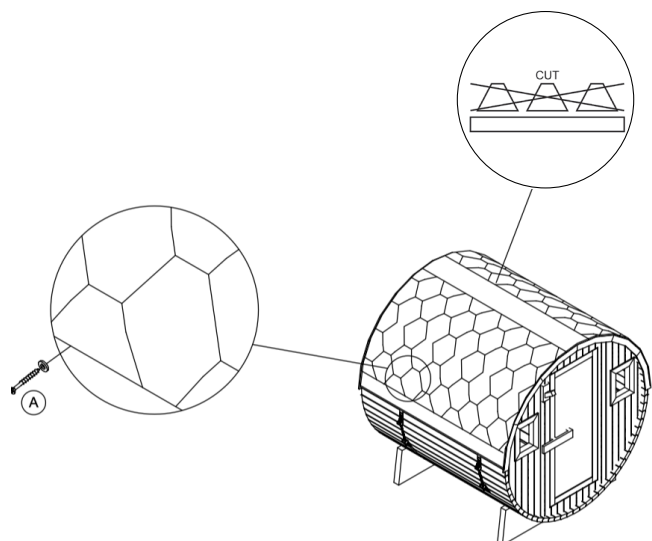

# Maintenance

## Maintaining Your Sauna After Installation

### • Exterior Wood Treatment

Your sauna is designed for outdoor use, and the wood we use is naturally resistant to the elements. Nonetheless, over time your sauna will naturally weather, and the color of the wood will start to turn gray, especially in sunny areas. If you'd prefer to preserve the original exterior color of your sauna or even change the color completely, we recommend treating the **exterior only** with a water-based stain-and-seal. A stain-and-seal treatment will add extra protection against mildew as well. **Please note it is important that the inside of the sauna remains untreated to prevent fumes.**

### • Roofing and Waterproofing

Without a roof installed, it is normal to experience water leaking through the roof boards. The interlocking staves do not form a watertight seal. We recommend installing our asphalt roof shingles, or sourcing your own roofing materials locally. Some customers have installed metal roofs or cedar shingles which work.

It's normal for some water to seep into your sauna, especially on windy days if rain is blowing onto the side walls of your sauna. This will not harm your sauna or diminish its lifespan. After a heavy rainfall, we recommend you run the heater for a 1-hour cycle to dry out the room. Running the heater a few times a week during the wetter months will help prevent mold or mildew from developing.

### • Interior Maintenance and Cleaning

Treating your benches with paraffin oil will reduce the amount of sweat and dirt absorbed into the wood. We recommend treating new benches before using them; repeat the treatment once or twice a year after cleaning the sauna. Paraffin oil is colorless and odorless, and it will give the wood a slightly darker 'wet' look after it's applied. Be sure to **only use sauna-grade paraffin oil**, like Harvia Paraffin Oil, to prevent fumes. Paraffin lamp oil should not be used under any circumstances. Wood surfaces must be completely dry before applying an oil treatment.

Under normal conditions, washing the interior of the sauna every 3 to 4 months will maintain cleanliness. We recommend using Harvia Sauna Cleanser or another suitable cleaning solution for wood. Refrain from using ammonia or harsh chemicals.

Clean the wood with a sponge or soft bristle brush and your cleaning solution. Always brush with the grain of the wood. If dirt is embedded in the benches, you can sand them down lightly. Rinse the sauna thoroughly with water to remove all the cleaning product. Run the heater for 1 to 2 hours to dry out the room and then leave the door open to air out the sauna.

For stainless steel surfaces on your heater, we recommend Harvia Sauna Heater Cleanser which removes limescale stains.

Re-stack your sauna rocks every 6 months as the rocks will break down over time in high heat. Ensure that the rocks do not shift and cause the heater coils to bend into one another. We recommend replacing your sauna rocks completely every 12-18 months.

**After you have finished each sauna session**, we recommend running the heater for an additional 60 minute cycle with the door closed. This will dehumidify the room and dry out the wood. If you are using your sauna regularly (i.e., multiple times a week) and drying out the room after each session, this should largely prevent mold formation.

**If you are not using your sauna regularly**, run a dehumidifier and/or fan inside the sauna to keep air circulating (and empty the dehumidifier water tank regularly). Also place desiccants (e.g., a commercial desiccant such as Damp-Rid or non-commercial desiccant such as charcoal briquettes/kitty litter) on dishes and place them around the inside of the sauna.

#### • **Preventing and Treating Mold**

The key to preventing mold from forming is to ensure the inside of the sauna is frequently dried out. Mold can develop as a result of moisture getting trapped inside the sauna over prolonged periods of exposure to sweat and steam or precipitation.

If you see mold on the inside or outside of your sauna, this should be treated early before it has time to grow and take hold. Clean the affected area with household white vinegar and gently scrub the area with a soft scrub brush and soapy water.

If you are unable to remove the mold with vinegar and soap, try stronger cleaning agents such as 30 Seconds Outdoor Cleaner or Behr All-in-One Wood Cleaner. Rinse the sauna thoroughly with water to remove the cleaning solution. Run the heater for 1 to 2 hours to dry the room. Any rags or scrub brushes that come into contact with the mold must be disposed of. **Proper protective equipment (goggles, mask, gloves, etc.) must be worn when removing mold.**

#### • **Instructions for First Time Use**

Before placing the rocks in your heater, wash them off and dry them to remove any dust. Once they are dry, add the rocks to your heater. Make sure your rocks are not stacked too tightly to allow for appropriate air flow.

To prepare your heater for your first sauna session, turn your heater on to its highest heat setting for an hour. This will burn off the protective oil on the heater coils that may cause a mildly unpleasant smell. The sauna should not have anyone bathing in it during this cycle. Never run your heater without the rocks. After the initial 1 hour cycle, leave the door open and let the sauna air out for several hours.

Now your sauna is ready to use!

# Warranty

## Warranty

Our saunas and sauna heaters come with a 1-year limited warranty. Please refer to <https://www.redwoodoutdoors.com/warranty> for detailed warranty information on our products.

## Serial Number

Each of our saunas is fitted with a unique serial number. This number is used to verify your sauna's authenticity as well as streamline service requests.

**2503C1S0001**

Example Serial Number Plate

The plate is attached to one of your sauna's base pieces. You can position it on the side opposite to your sauna's door, so it is not visible during daily use.

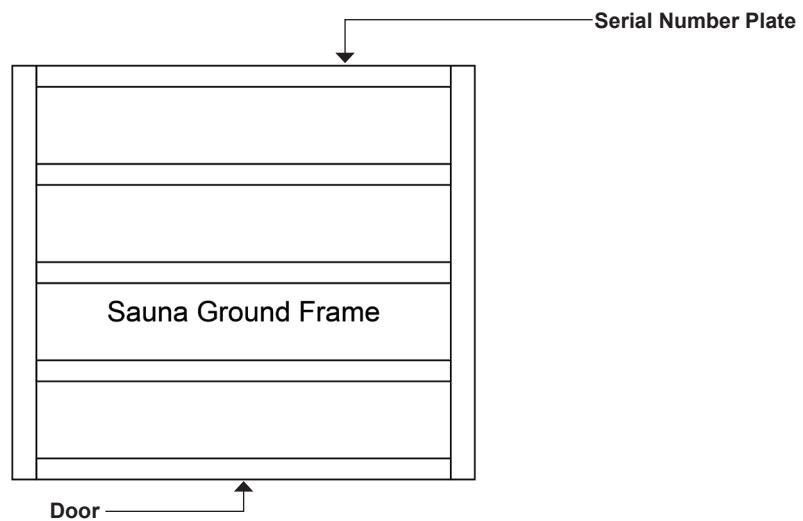

Please make a note of your sauna's serial number. If you require assistance, **please include the serial number in your email to Redwood Outdoors' customer support team.** This will allow our team to quickly access your production and shipping details so we can resolve any issues promptly.

## User Guide

### How to Take a Traditional Finnish Sauna

- Traditional sauna bathing is done in 'rounds' or intervals. A round involves heating the body up and then cooling it down. A typical round consists of 10-15 minutes in the sauna followed by a cool down period of approximately 5 minutes.
- Preheat the sauna to your desired temperature (traditional Finnish saunas run between 160°F and 185°F). Preheating typically takes 45 minutes to an hour. If the ambient temp outside is below 20°F, preheating may take longer than one hour. Digital sauna heaters can be started remotely via Wi-Fi. Manual control sauna heaters can be set on a delay timer to start at a predetermined time up to 8 hours in the future.
- All residential sauna heaters have a maximum independent run time of 1 hour for safety reasons, but they can be restarted again as many times as desired. When you enter the sauna for your first round, begin by resetting the heater to the full 1 hour.
- The first sauna round is typically enjoyed dry, which means no water is added to the rocks. Heat stacks in a sauna, so it's normal that the floor will be much cooler than at your head. If you find your head gets too hot, you can wear a sauna hat, which will help keep your head cooler and allow you to feel more of the heat sensation on your body.
- After 10-15 minutes, exit the sauna and begin your cool down phase. If you have an outdoor shower or cold plunge tub, this can be used during your cool down and provides for a much more rapid and effective cool down phase. The goal is to bring your body temperature back down in preparation for the next hot phase.
- The 2nd and 3rd sauna rounds are typically enjoyed with added humidity, which increases the sensation of heat. Water can be gently ladled on to the rocks to create steam or 'löyly'.
- You may add aromatherapy oils to your water bucket to create a scented steam. The classic scents used in Finland are birch, pine and eucalyptus. All aromatherapy oils are formulated differently, so make sure yours does not leave any residue on the rocks.
- When pouring water on the rocks, do so slowly and only when the sauna is at full temperature. The water should evaporate instantly when it hits the rocks. If you notice water coming out the bottom of the heater it means you are pouring too fast or too much. If you like to use a lot of water in the sauna, it is recommended to buy a sauna fountain. These stone fountains sit amongst the rocks and help create steam.
- A typical sauna session is 2 or 3 rounds. Do not skip the cool down phase on your final round. A sauna session ends with a cool down, after which you can take a warm shower.
- It is important to drink water during a sauna session. You should aim to drink at least 24 ounces of water during a session.
- Excessive heat exposure can be harmful to a person's health. People with certain health conditions should consult their physicians before using the sauna.

***SAUNA BATHING IS NOT RECOMMENDED FOR CHILDREN UNDER 14.  
CHILDREN MUST BE SUPERVISED BY ADULTS.***

# User Guide

## Important Note About Heat-Up Times

**During colder winter months, your sauna will take longer to reach the desired temperature.** This is **normal** and is due to external conditions.

Several factors contribute to slower heat-up times in winter:

- **Ambient Temperature:** When your sauna starts heating from a low outdoor temperature—especially near or below freezing—the heater must work harder and longer to raise the room's temperature.
- **Cold Rocks:** It takes longer to heat the rocks in the heater that are at the same low temperature as the air inside your sauna. The rocks must heat up first before the room can start heating.
- **Heat Loss Through Surfaces:** The sauna's walls, floor, and roof are much colder. These surfaces absorb heat and lose heat to the environment as the sauna warms up, reducing the speed the room's temperature rises.
- **Wind and Airflow:** Outdoor air movement can increase heat loss, especially if the sauna is not in a sheltered location.
- **Humidity and Snow:** Moisture in the air, snow on the roof, or frost on the panels can draw heat away from the interior as the heater operates.

### To improve heat-up times in winter:

- Allow extra time for the sauna to preheat before use.
- Make sure the door is kept closed to minimize heat loss.
- Clear snow or frost from the exterior before use if possible.
- Consider installing a windbreak or shelter if your sauna is in a particularly exposed area.

Please note that most sauna heaters have an automatic safety shutoff after 60 minutes. To continue heating after 60 minutes have passed, you must restart the heater.

## IMPORTANT NOTICE

YOU ARE SOLELY RESPONSIBLE FOR: (A) ENSURING COMPLIANCE WITH ALL APPLICABLE BUILDING CODES, ZONING, ORDINANCES, BUSINESS DISTRICT OR ASSOCIATION RULES, COVENANTS, CONDITIONS, AND RESTRICTIONS, LEASE OBLIGATIONS, LANDLORD OR OWNER APPROVALS OR REQUIREMENTS RELATED TO ANY PRODUCTS YOUR PURCHASE; AND (B) OBTAINING ANY PERMITS OR AUTHORIZATIONS NECESSARY FOR INSTALLATION AND/OR USE OF SUCH PRODUCTS, INCLUDING ANY PAYMENT OF ANY FEES OR OTHER CHARGES FOR PERMITS OR AUTHORIZATIONS (COLLECTIVELY, "LEGAL REQUIREMENTS"). THIS INSTALLATION MANUAL IS PROVIDED SOLELY AS A COURTESY TO YOU AND DOES NOT CONSTITUTE ANY WARRANTY BY REDWOOD OUTDOORS TO YOU REGARDING THE PLACEMENT OR INSTALLATION OF THE PRODUCT. THIS MANUAL IS NECESSARILY GENERAL IN NATURE AND MAY NOT TAKE INTO CONSIDERATION ALL OF THE CONDITIONS AND CIRCUMSTANCES OF YOUR PROJECT. YOU ARE SOLELY RESPONSIBLE FOR DETERMINING WHETHER THE PLACEMENT AND INSTALLATION OF THE PRODUCT IS APPROPRIATE AND IN COMPLIANCE WITH ALL LEGAL REQUIREMENTS. YOU SHOULD CONSULT QUALIFIED CONSTRUCTION, ELECTRICAL, ENGINEERING OR OTHER SERVICE PROFESSIONALS IF YOU HAVE QUESTIONS ABOUT THE PROPER INSTALLATION OF THE PRODUCT. REDWOOD OUTDOORS AND ITS SUPPLIERS WILL NOT BE LIABLE TO YOU FOR ANY CLAIMS OR DAMAGES ARISING FROM YOUR INSTALLATION, MAINTENANCE, OR REPAIR OF ANY PRODUCT.



REDWOOD  
OUTDOORS

View this manual online  
here



View the assembly video  
here



### Contact Info

Phone: 1-800-567-8036  
Email: [support@redwoodoutdoors.com](mailto:support@redwoodoutdoors.com)  
Website: [www.redwoodoutdoors.com](http://www.redwoodoutdoors.com)

### Version

Date: Aug 26, 2025  
Version: 8.2