

Assemble Instruction

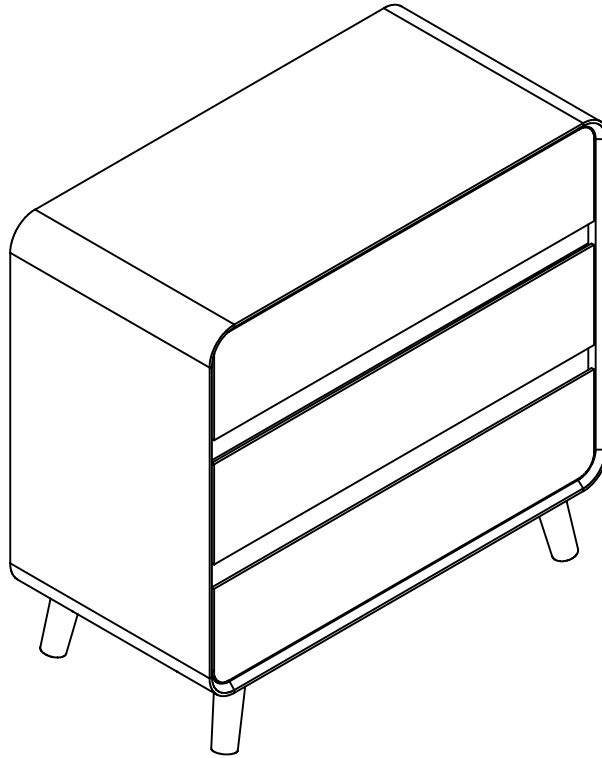

As this item contains many parts, please read the installation instruction carefully before installation and complete the installation with the cooperation of your partner. Please use tools properly and carefully. If you have any questions about the product and installation, please contact us.

Before You Start

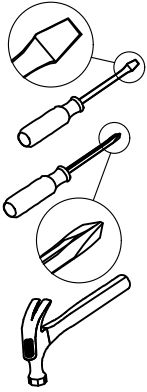

- ✓ Read through each step carefully and follow the proper order
- ✓ Separate and count all your parts and hardware
- ✓ Give yourself enough room for the assembly process
- ✓ Have the following tools: Flat Head Screwdriver, #2 Phillips Head Screwdriver and Hammer
- ✓ Caution: If using a power drill or power screwdriver for screwing, please be aware of to slow down and stop when screw is tight. Failure to do so may result in stripping the screw. (Assembly speed can be increased by using electric screwdriver)

Helpful Hints

PEOPLE NEEDED FOR ASSEMBLY: 1-2

- Open your item in the area you plan to keep it to avoid excessive heavy lifting.
- Identify, sort and count the parts before attempting assembly.
- Compression dowels are lightly tapped in with a hammer.
- Slides are labeled with an **R** (right) and **L** (left) for proper placement.
- Make sure to always face the point on the top of the Cam Lock towards the outer edge.
- If there is a back panel in the package, please install it to make sure your unit is complete and sturdy.
- Please fix all the screws provided for the back panel which can enhance product stability. If it is difficult to fix it when tightening, it can be fixed with the help of a hammer and then tightened.
- Do NOT use harsh chemicals or abrasive cleaners on this item.
- Never push, pull, or drag your furniture.

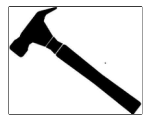
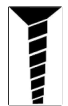
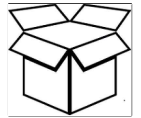

Board Identification

Not actual size

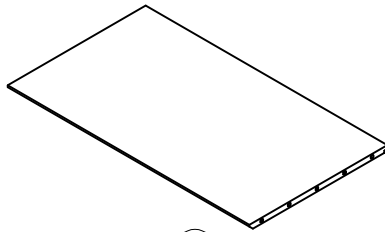

①

Qty: 1

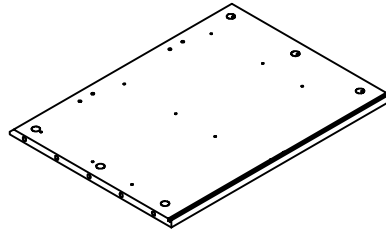

②

Qty: 1

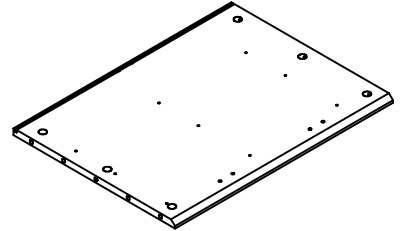

③

Qty: 1

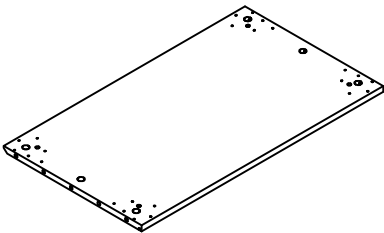

④

Qty: 1

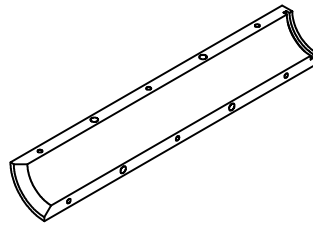

⑤

Qty: 4

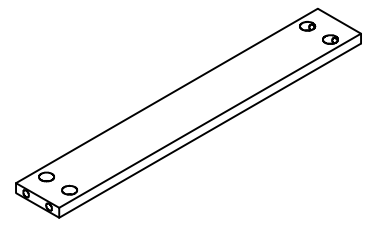

⑥

Qty: 2

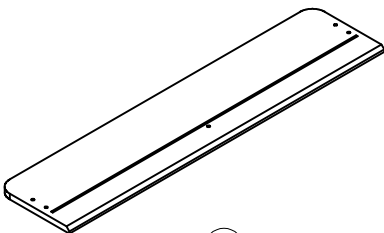

⑦

Qty: 1

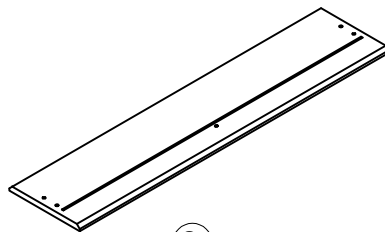

⑧

Qty: 1

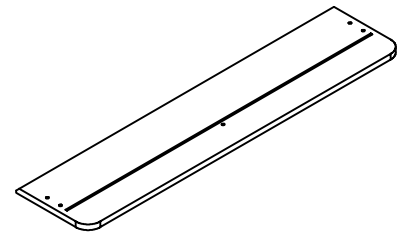

⑨

Qty: 1

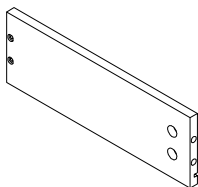

⑩

Qty: 3

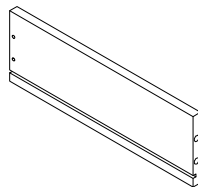

⑪

Qty: 3

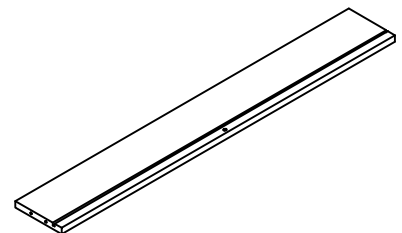

⑫

Qty: 3

Board Identification

Not actual size

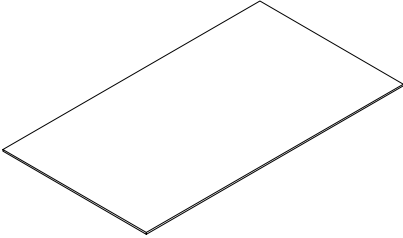

⑬

Qty: 3

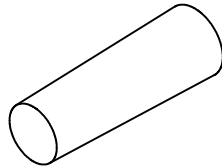

⑭

Qty: 4

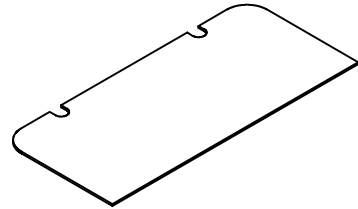

⑮

Qty: 1

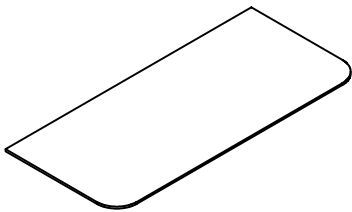

⑯

Qty: 1

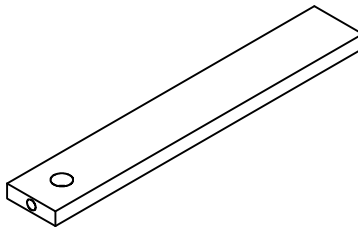

⑰

Qty: 3

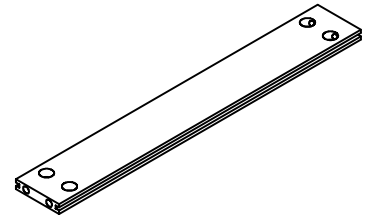

⑱

Qty: 1

Part List

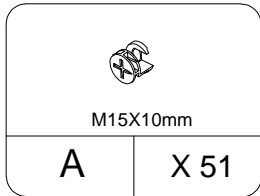

CAM LOCK
spare:2

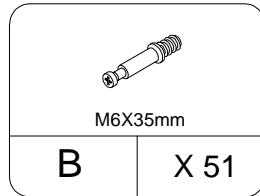

CAM BOLT
spare:2

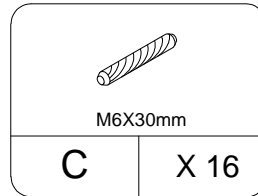

WOOD DOWEL
spare:2

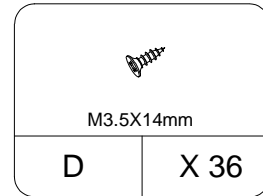

CONFIRMAT SCREWS
spare:2

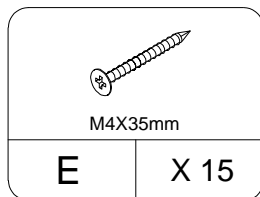

CONFIRMAT SCREWS
spare:1

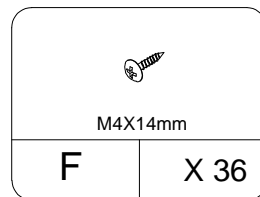

CONFIRMAT SCREWS
spare:2

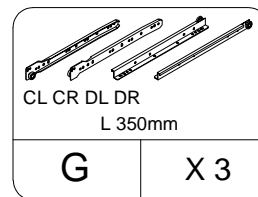

DRAWER RAILS

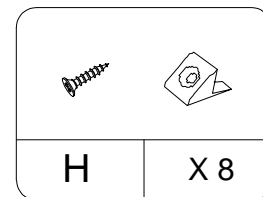

BACK PANEL BUCKLE
spare:1

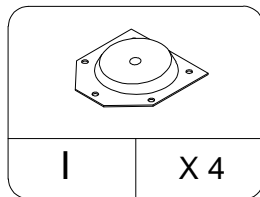

METAL SHEET

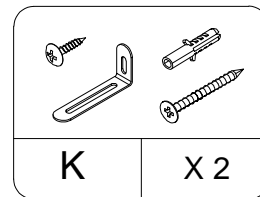

ANTI-DUMPING

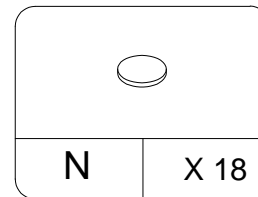

PERFECT STICKER
spare:2

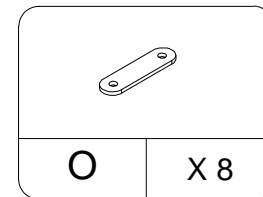

METAL PLATE

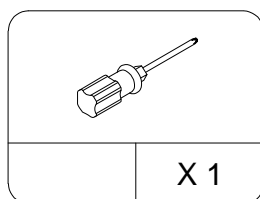

HEX KEY

Part List

Cam Lock Fastening System

Insert the cam bolt into the hole first, then insert the cam lock and lock it.

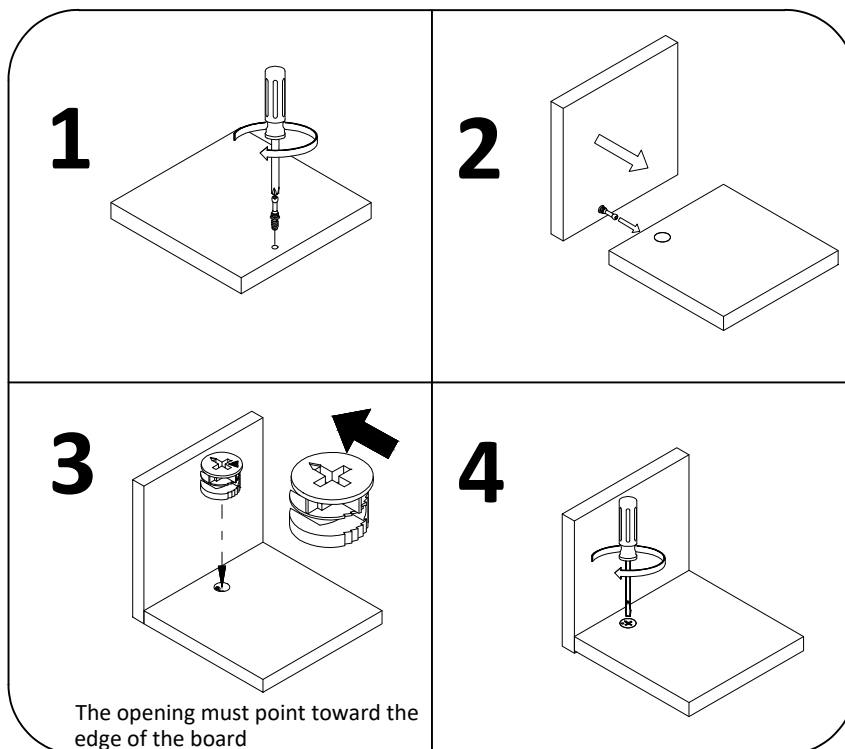

Board Identification

Not actual size

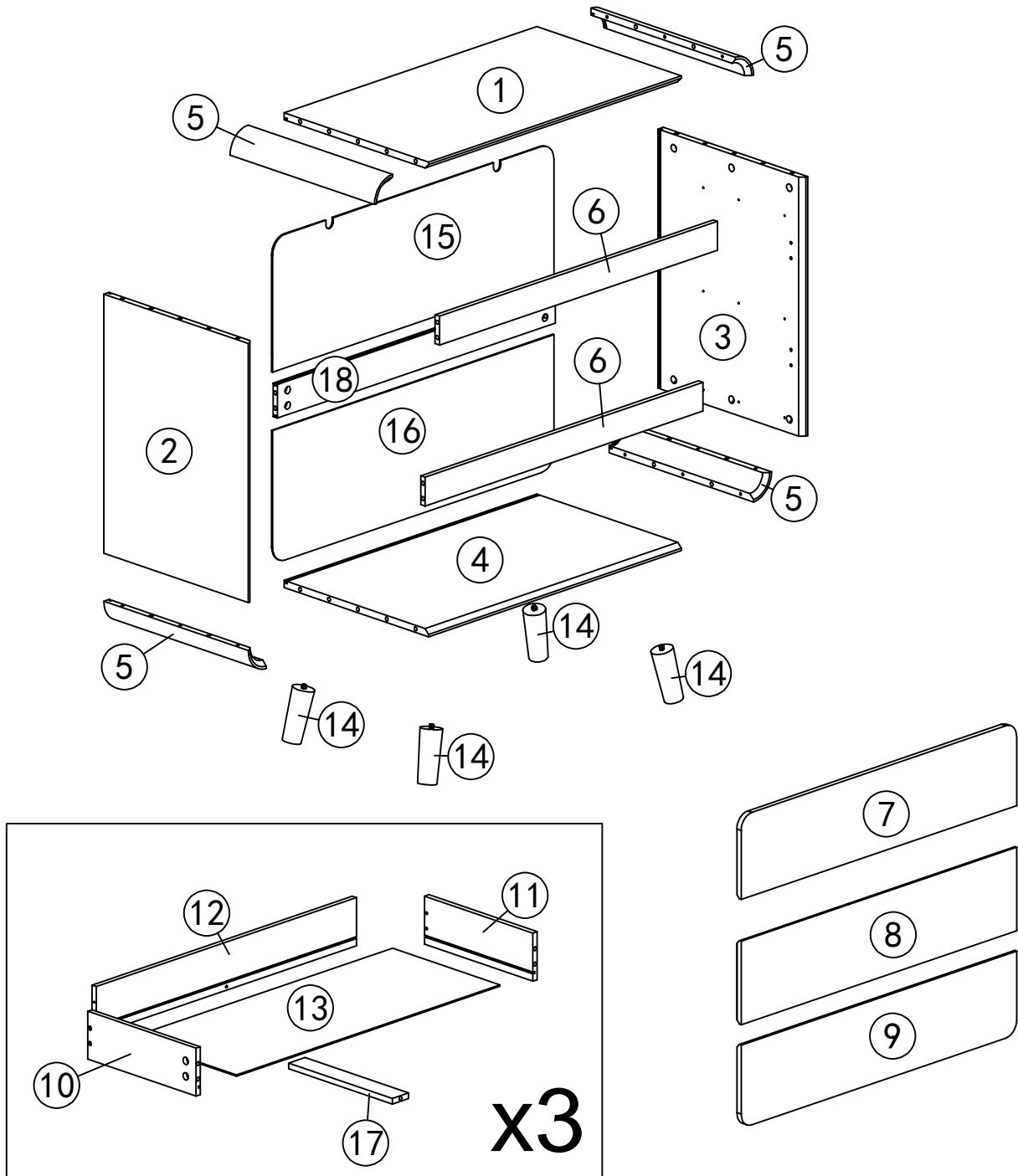

STEP1

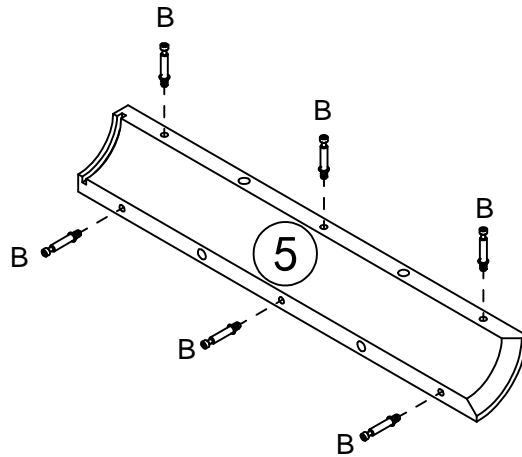
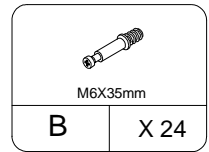
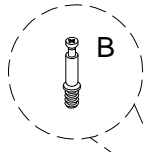
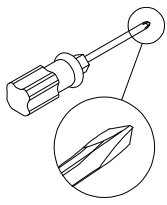

x4

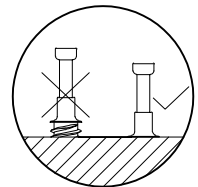

STEP2

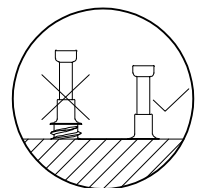
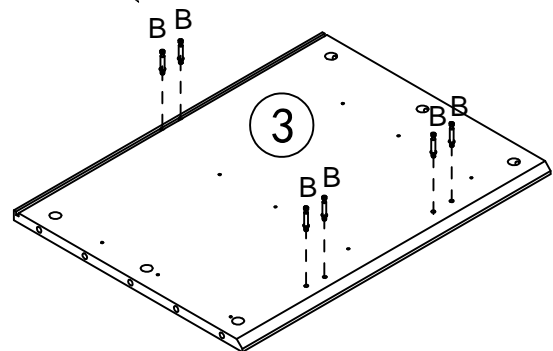
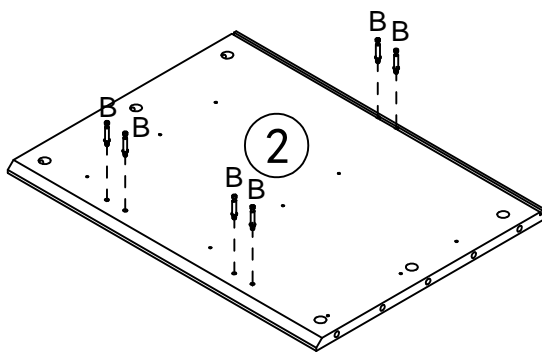
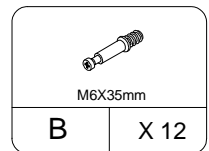
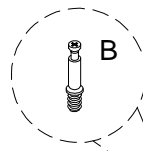
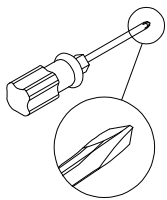

STEP3

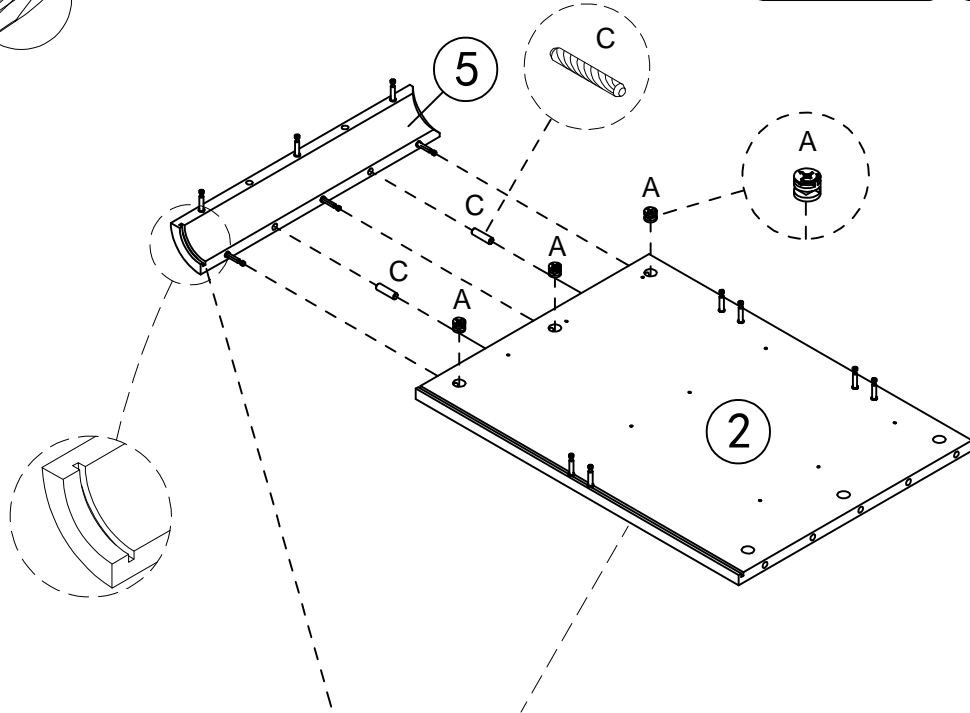
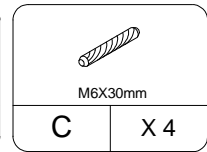
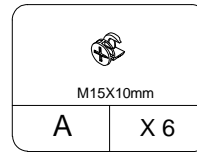
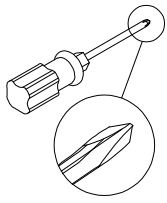

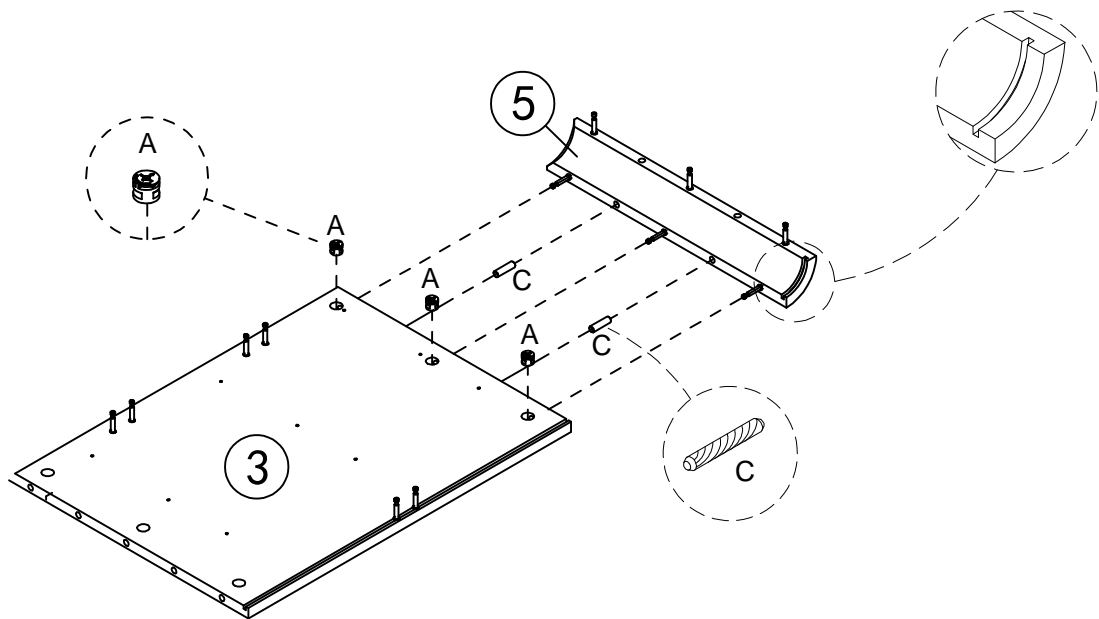

Ensure uniform groove direction during installation.

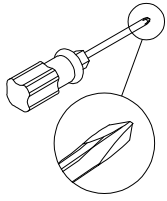

Insert the cam bolt into the hole first, then insert the cam lock and lock it.

STEP4



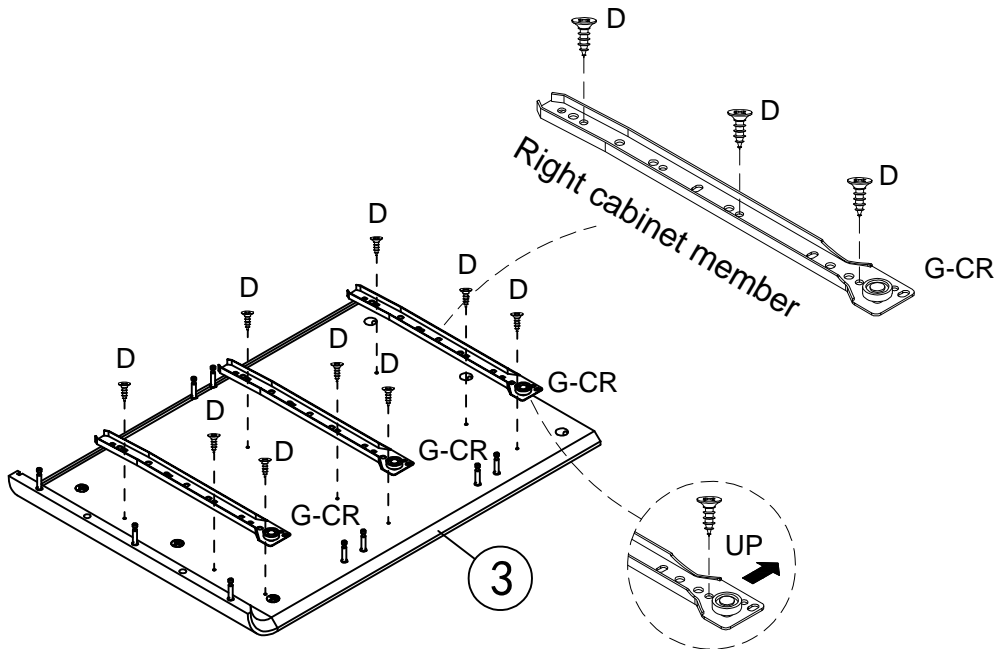
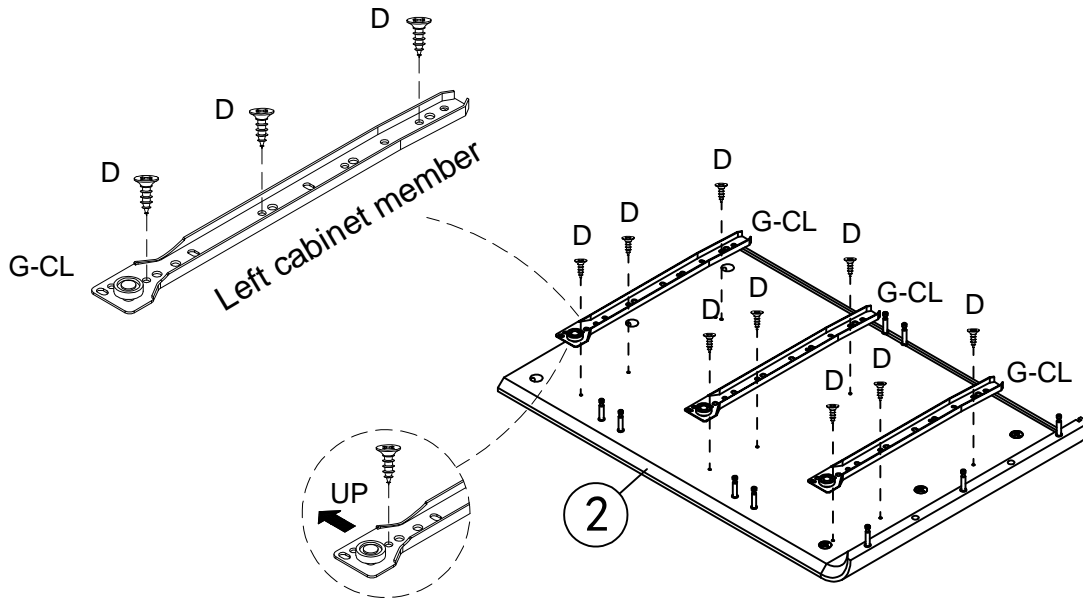

 M3.5X14mm	
D	X 18

 L 350mm	
G	X 3

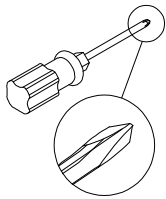

STEP5



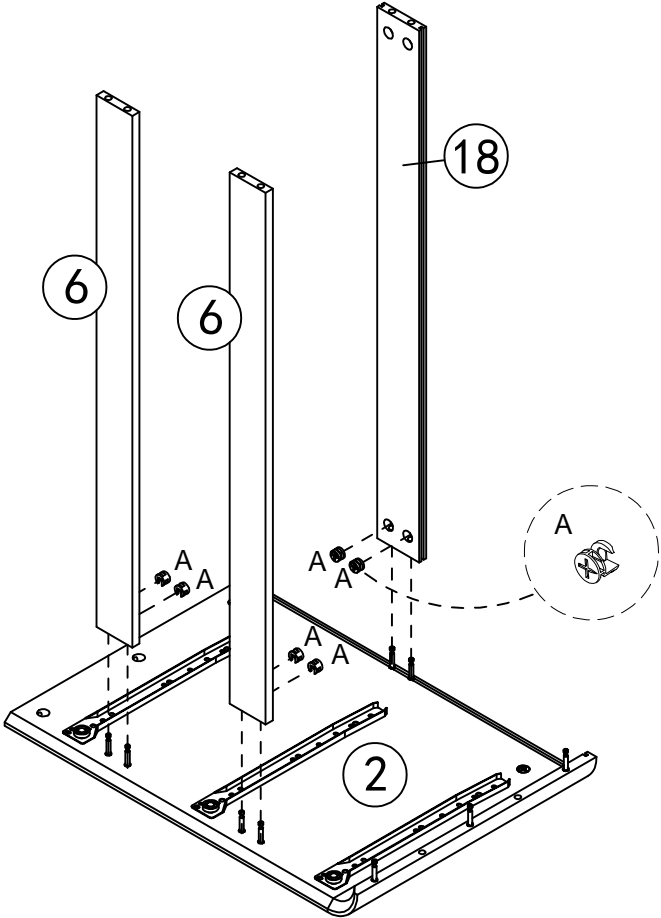

 M15X10mm	
A	X 6

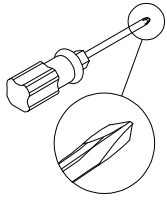

Insert the cam bolt into the hole first, then insert the cam lock and lock it.

STEP 6



	
M15X10mm	
A	X 3

	
M6X30mm	
C	X 2

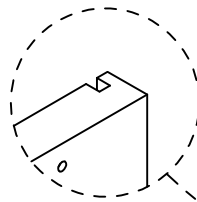

The slot is on the back side here.

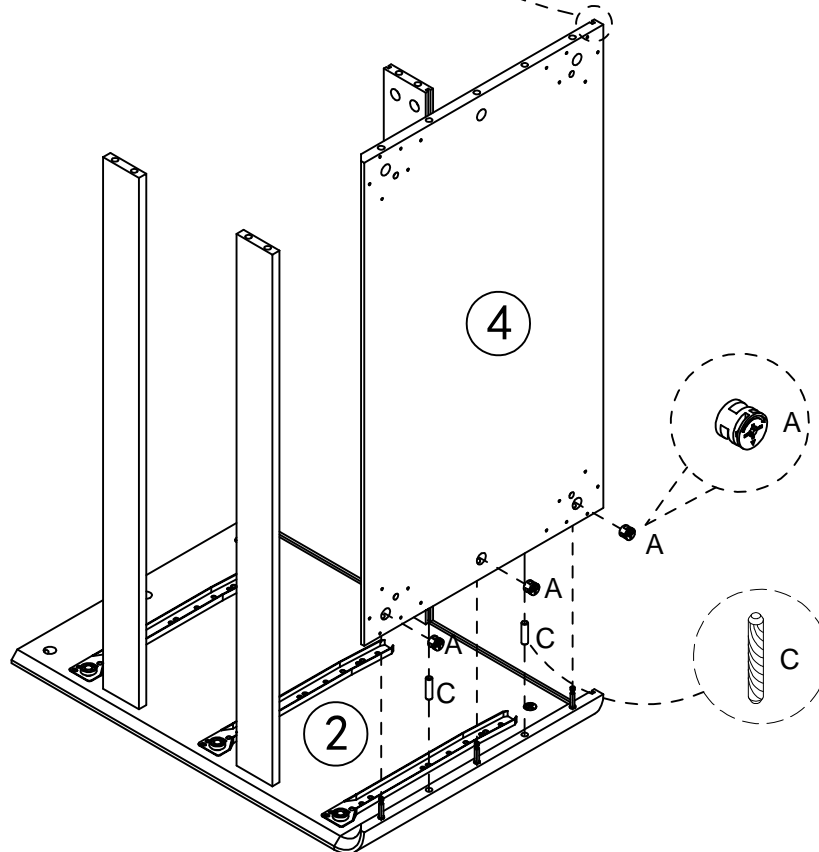

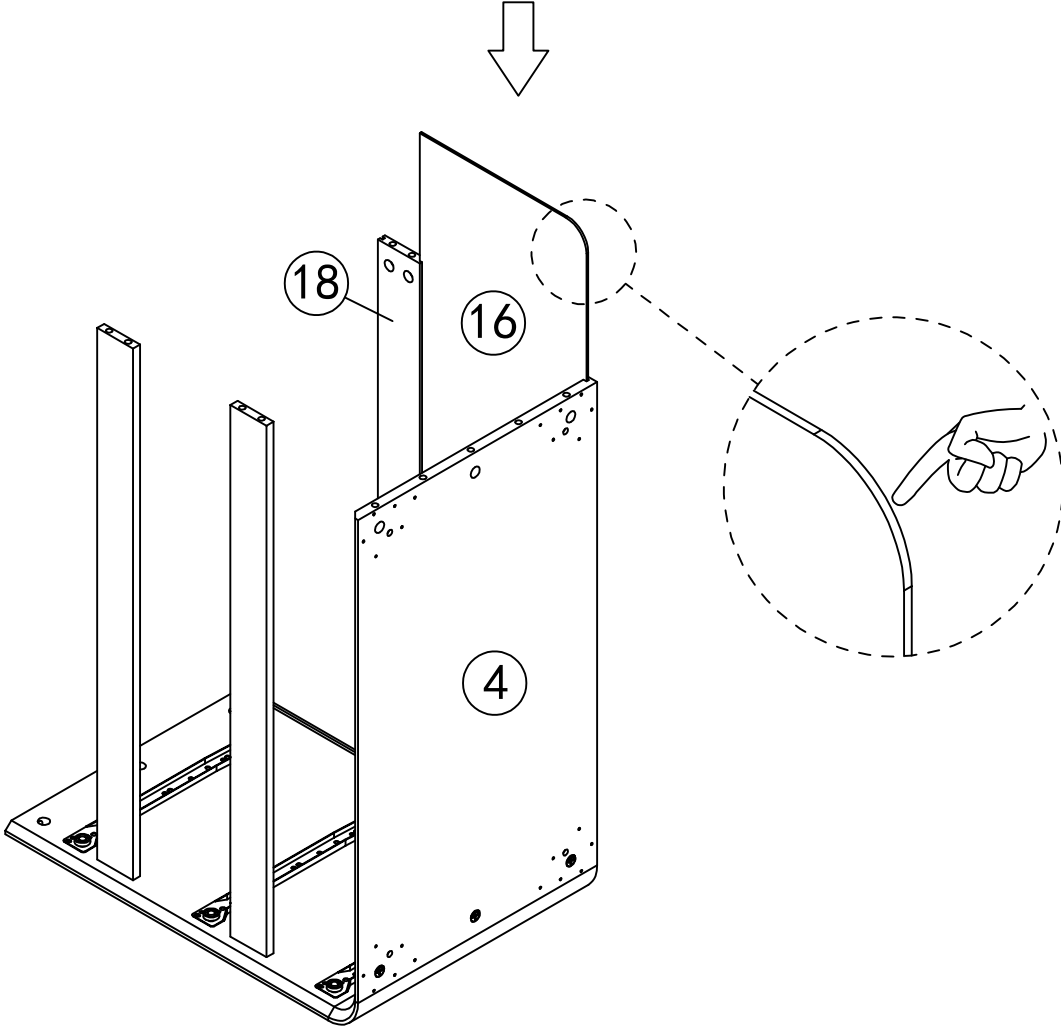
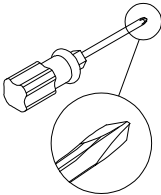

Insert the cam bolt into the hole first, then insert the cam lock and lock it.

STEP 7

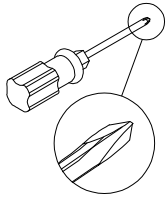

STEP8



	
M15X10mm	
A	X 9

	
M6X30mm	
C	X 2

Ensure uniform groove direction during installation.

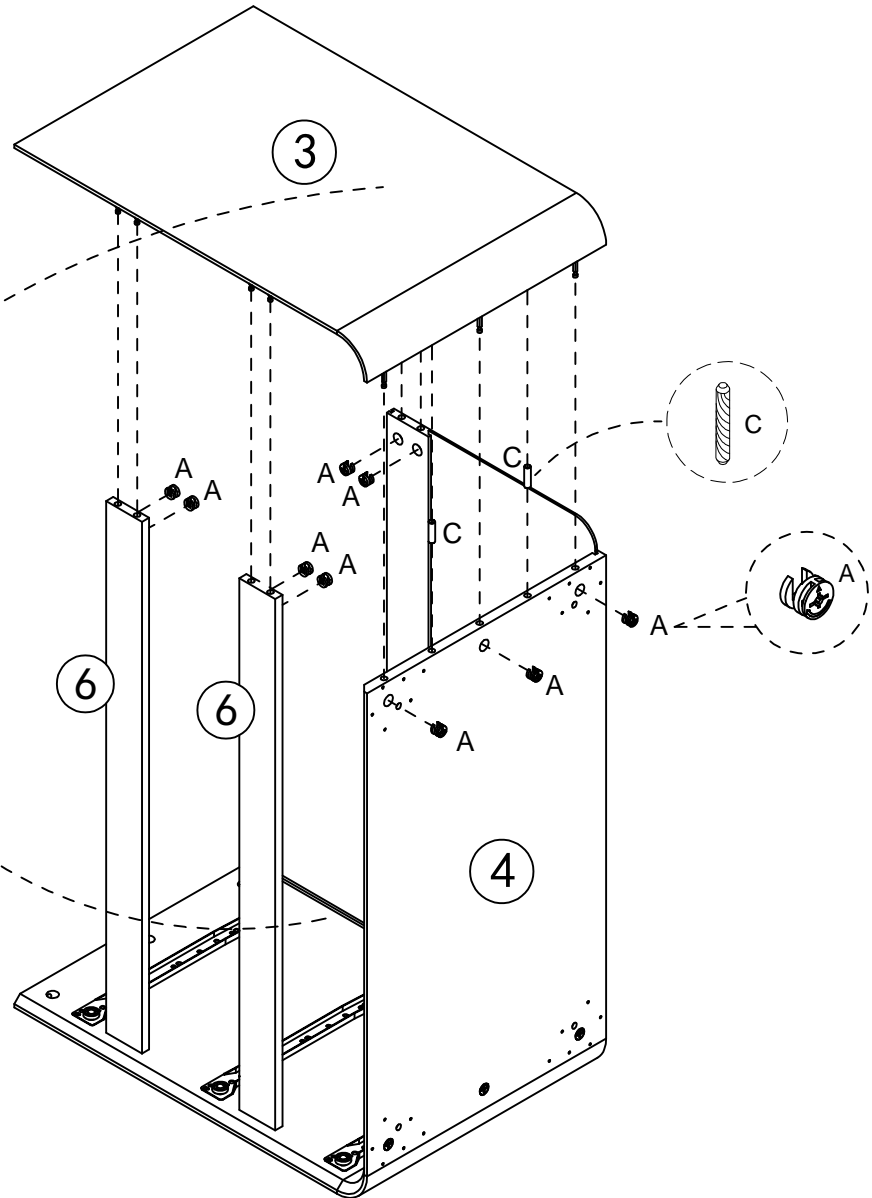

Insert the cam bolt into the hole first, then insert the cam lock and lock it.

STEP9

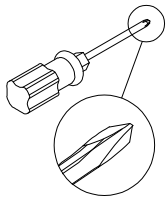

 M4X14mm	
F	X 20

	
I	X 4



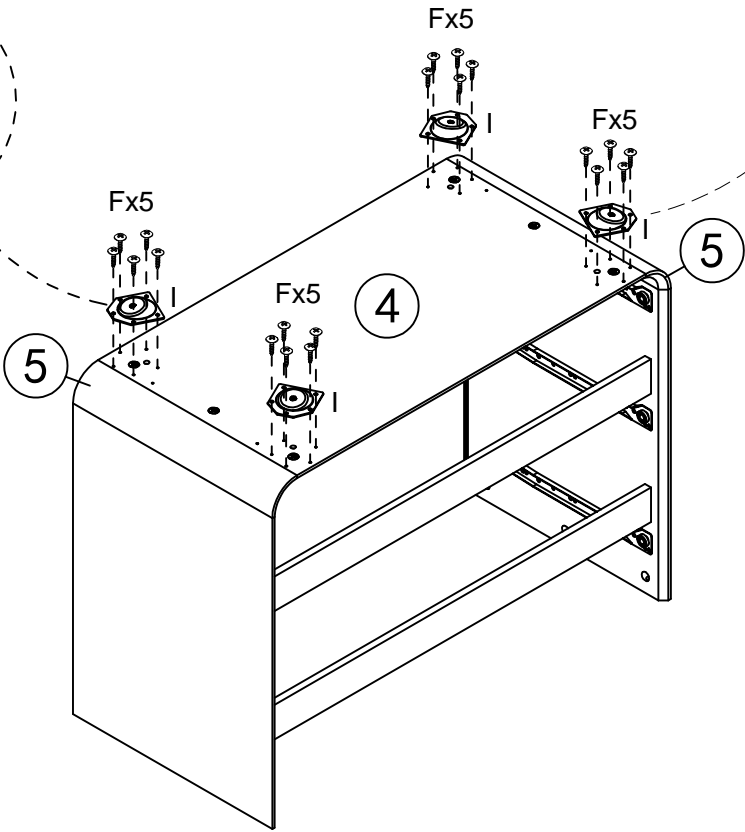
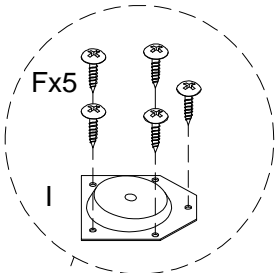
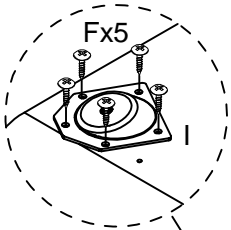

Higher edge facing inward.

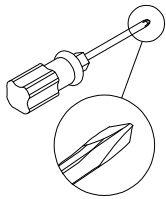

STEP10



 M4X14mm	
F	X 8

	
O	X 4



Using self-tapping screws F to install to plate ④ and ⑤.

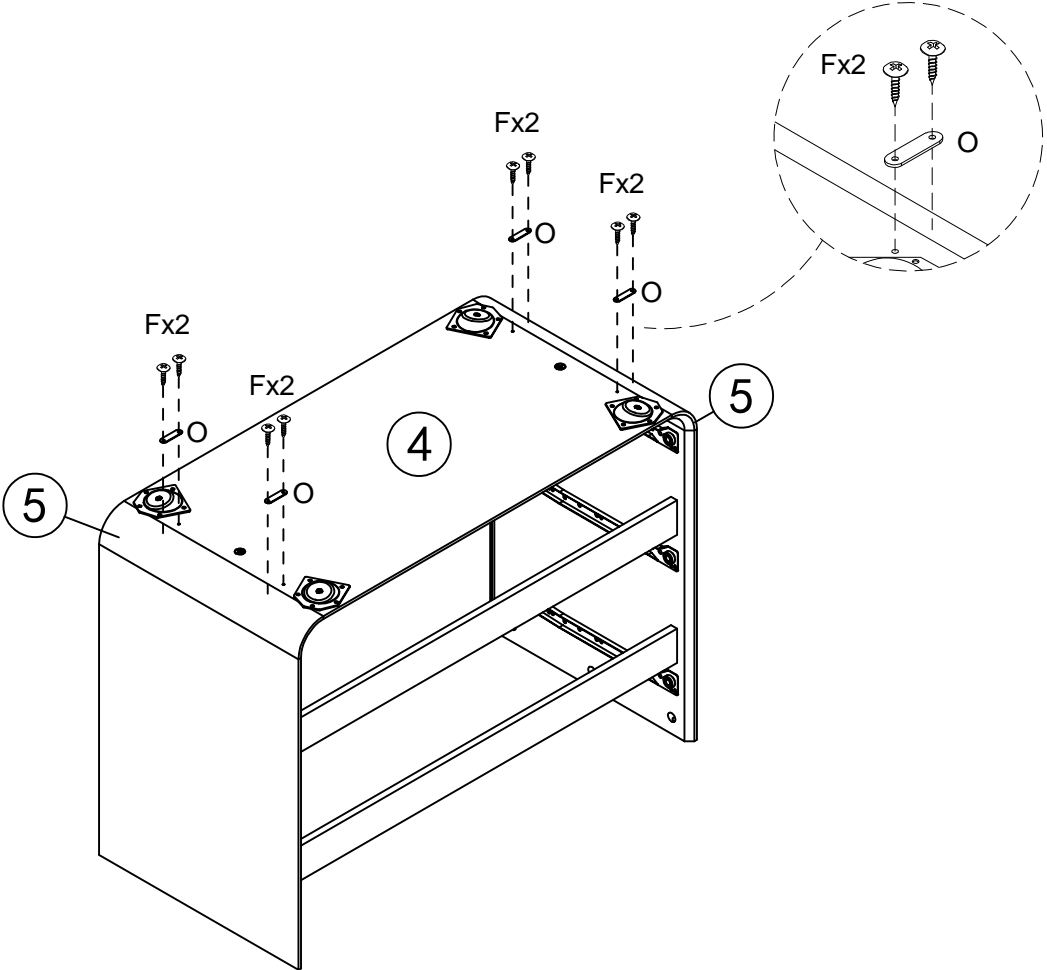

STEP11

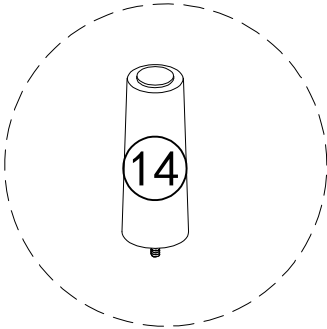

Align the screws on the 14 foot with the holes on the 4 plate, and rotate to install.

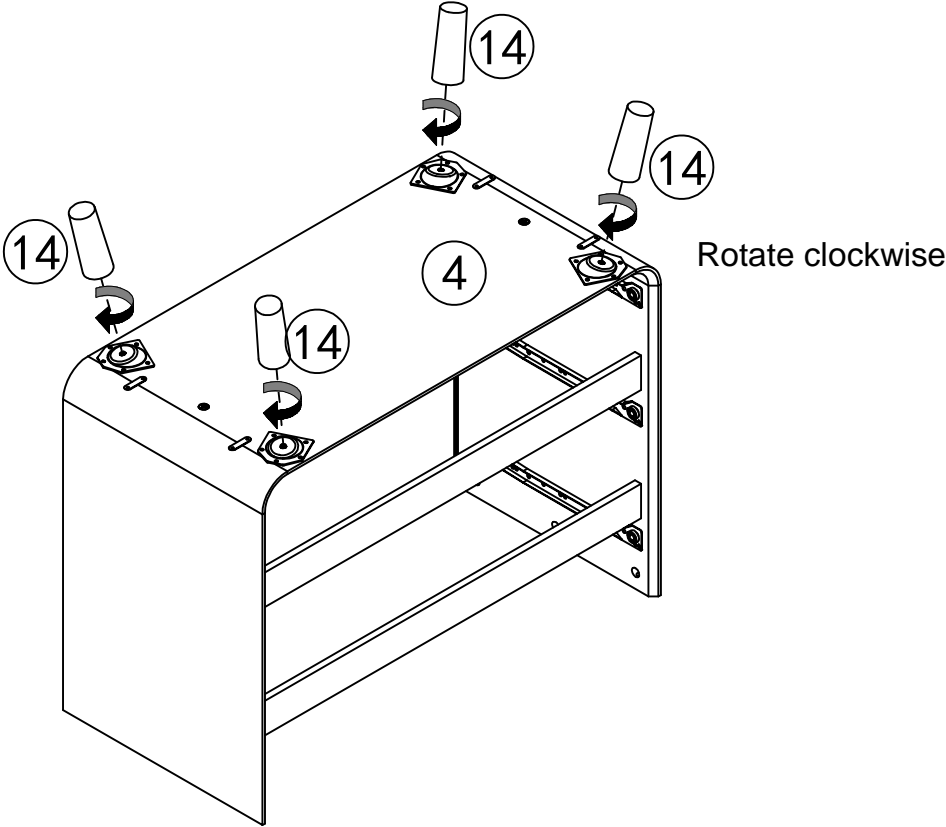

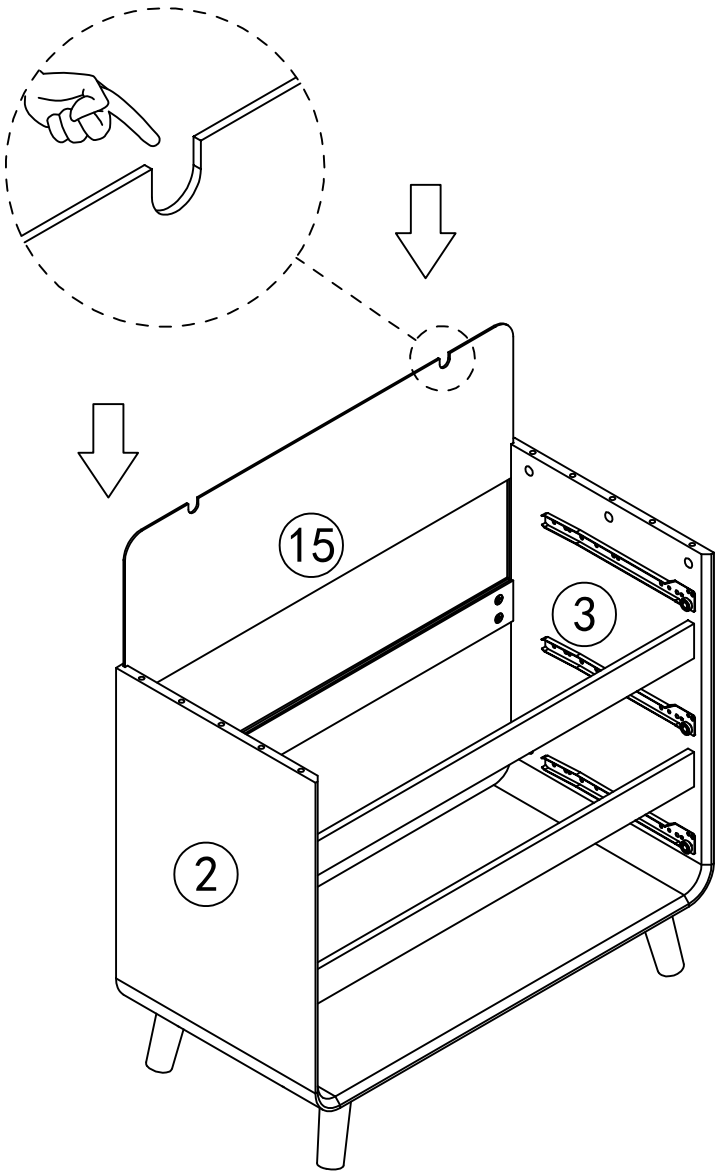

STEP12

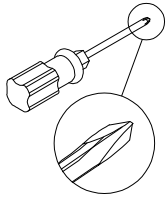

STEP13



	
M15X10mm	
A	X 6

	
M6X30mm	
C	X 4

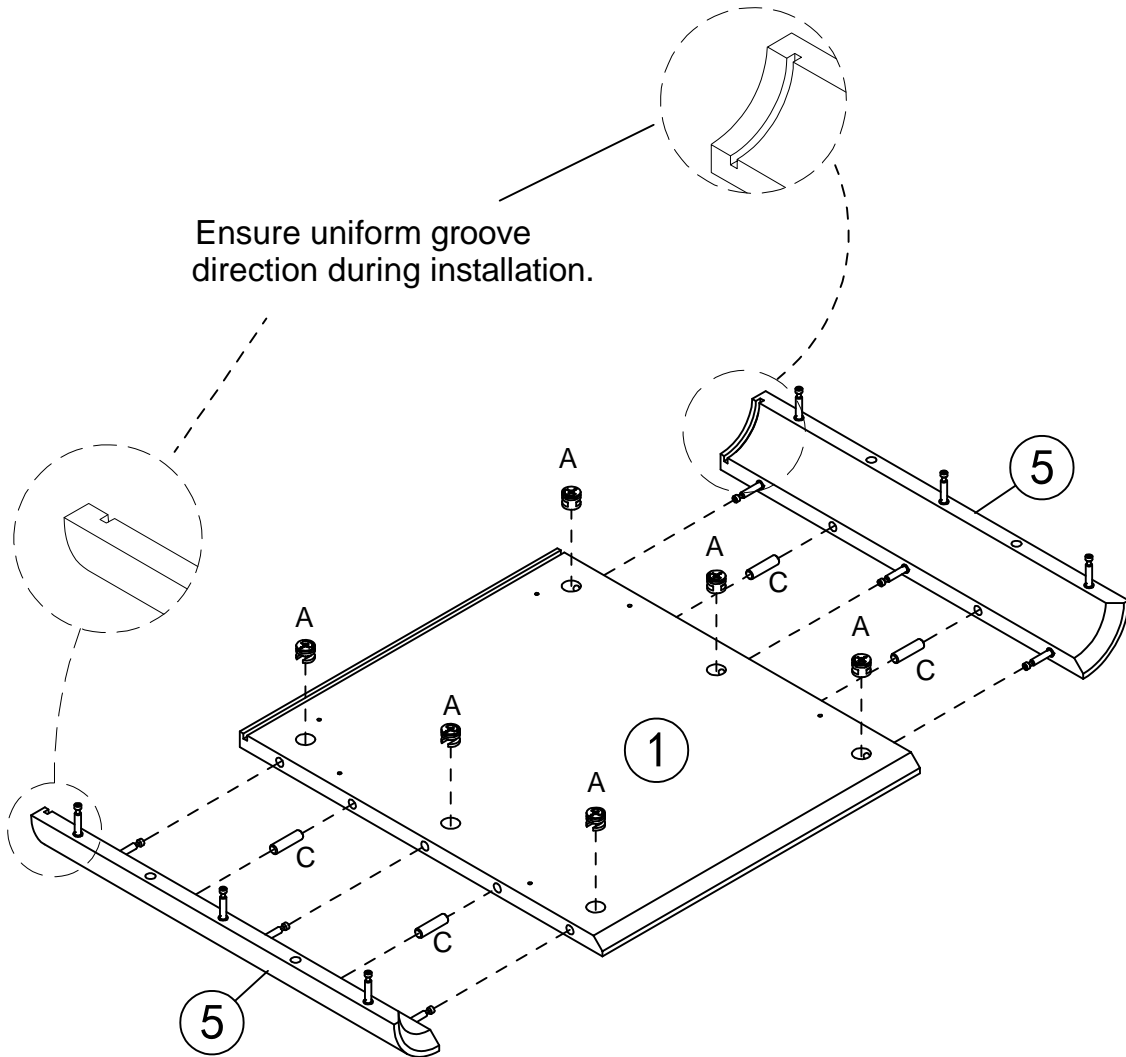

Insert the cam bolt into the hole first, then insert the cam lock and lock it.

STEP14

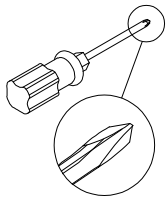

K-1	K-2
K	X 2

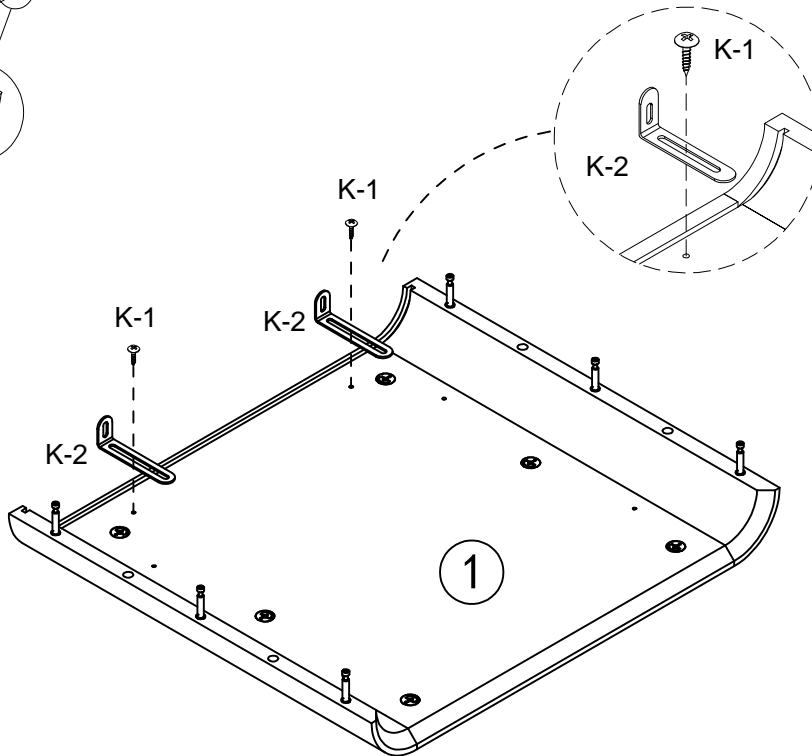

STEP15

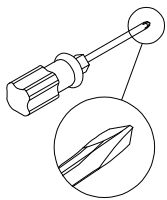

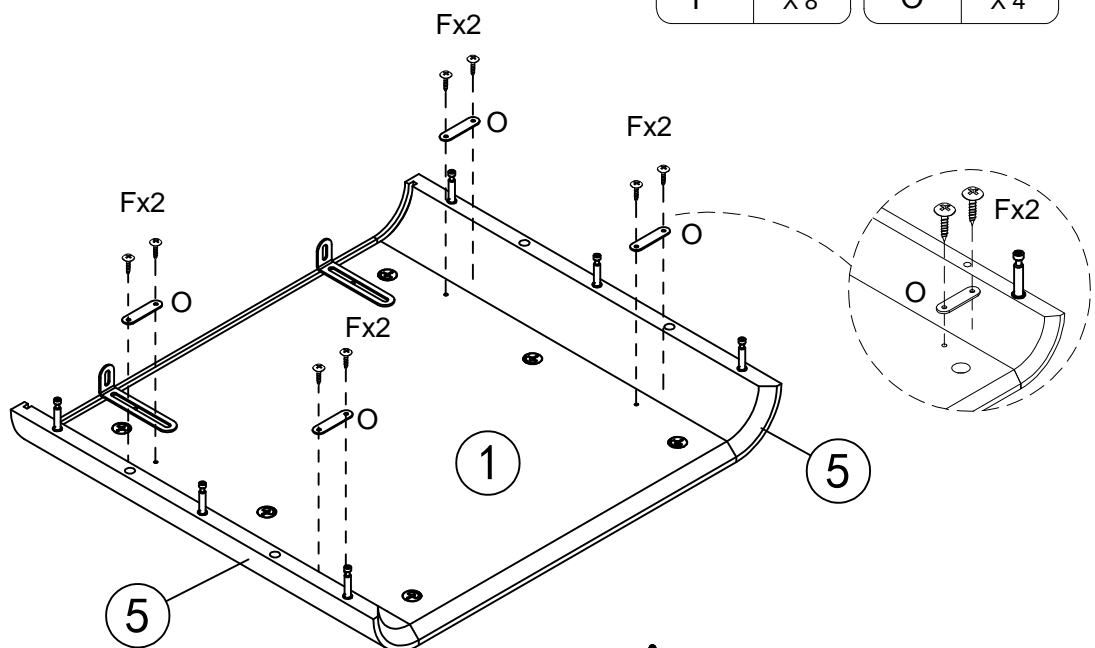

M4X14mm	
F	X 8
O	X 4

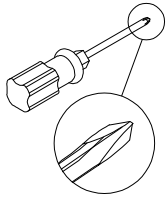

Using self-tapping screws F to install to plate ① and ⑤.

STEP16



	
M15X10mm	
A	X 6

	
M6X30mm	
C	X 4

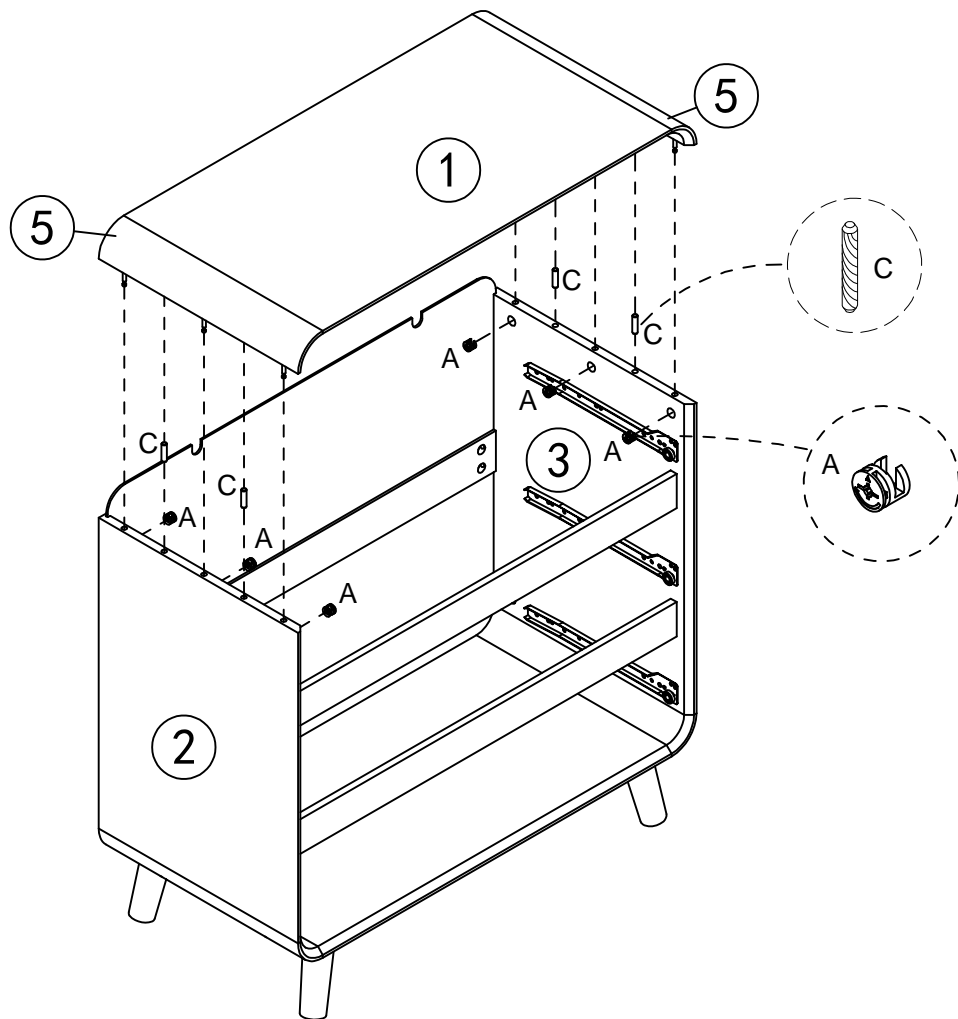

Insert the cam bolt into the hole first, then insert the cam lock and lock it.

STEP17

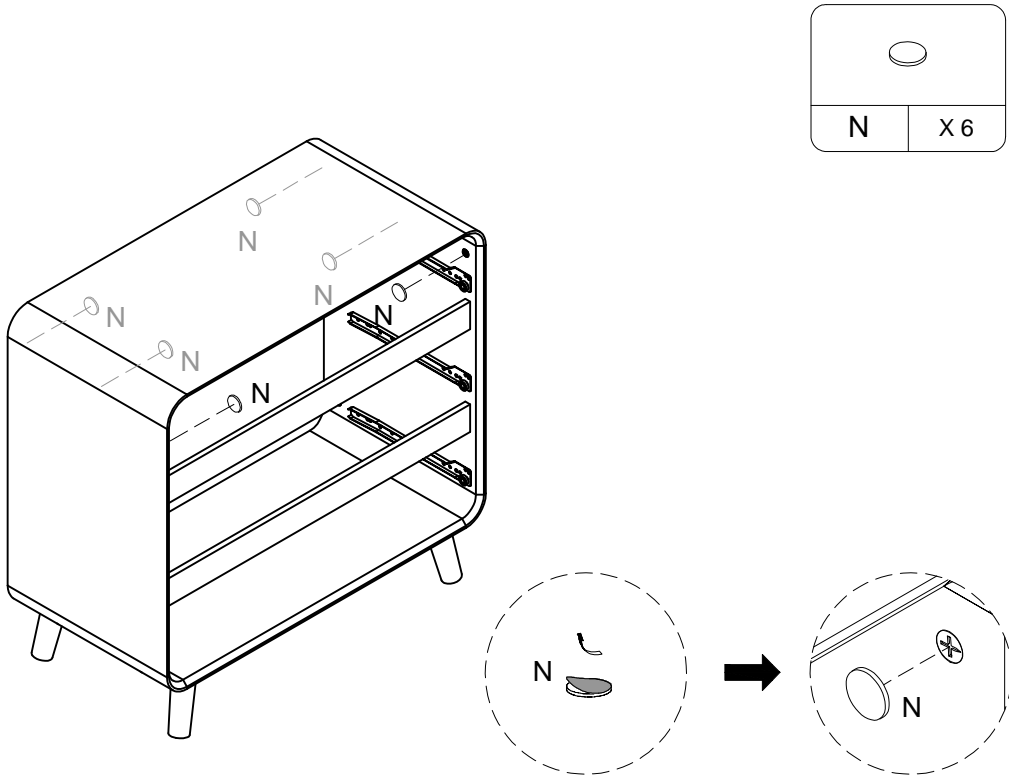

STEP18

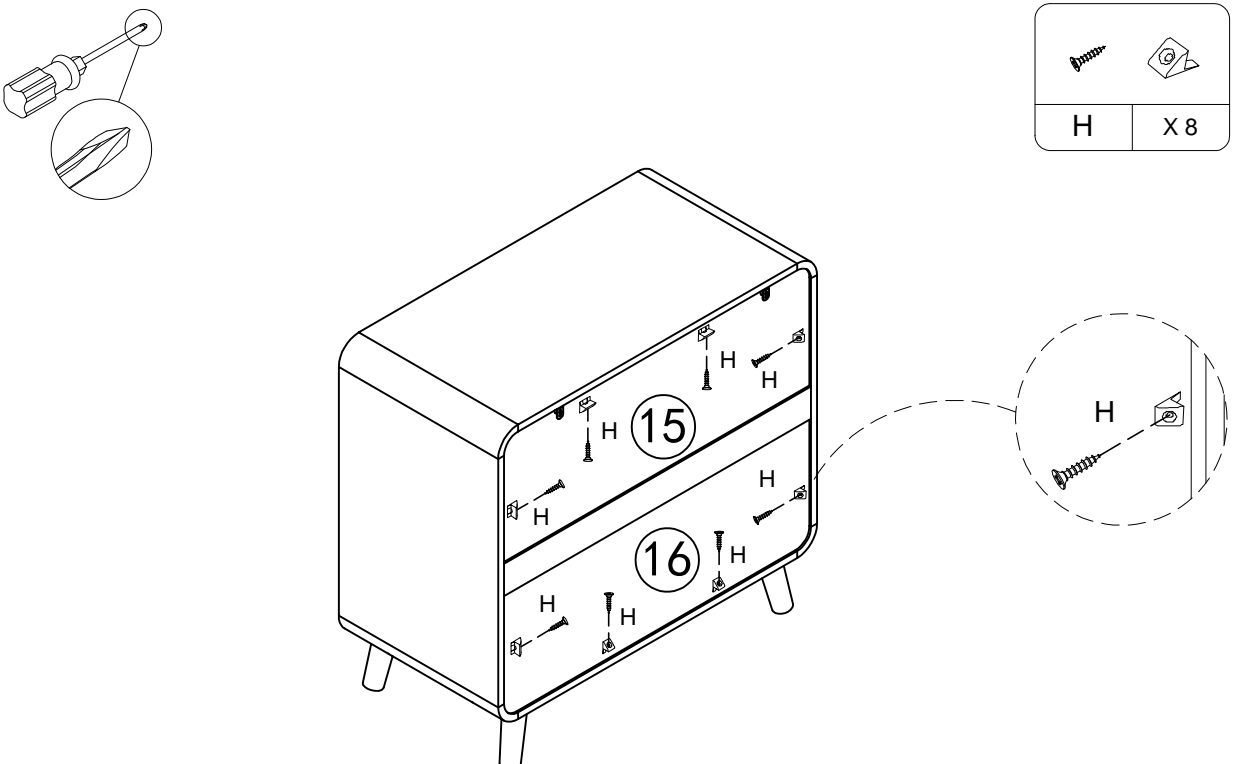

STEP19

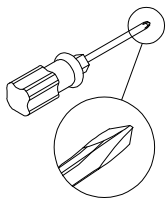

K-3	K-4
K	X 2

NOTE:The tipping restraint hardware included is for wooden stud wall construction. It must be attached to a wall stud. Depending upon your wall construction different anchor hardware maybe required. Please contact your local hardware store for assistance. Young children can be seriously injured by tipping furniture. You must install the tipping restraint hardware with the unit to prevent the unit from tipping, causing any accidents or damage. The tipping restraints are intended only as a deterrent and are not a substitute for proper adult supervision. The tipping restraints are not earthquake restraints. If you wish to add the extra security of earthquake restraints, they must be purchased and installed separately.

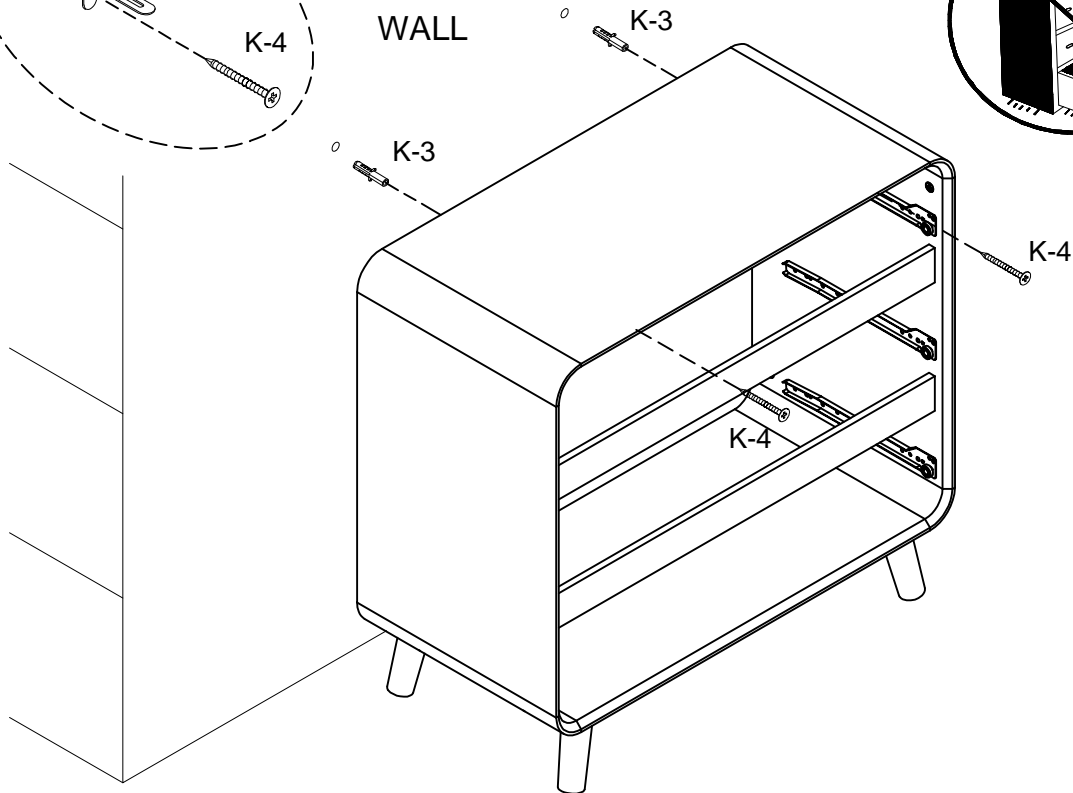
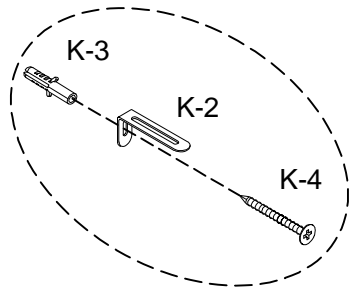

Install the tipping restraint hardware

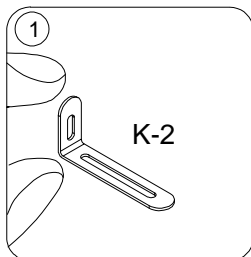

1. make mark on the wall

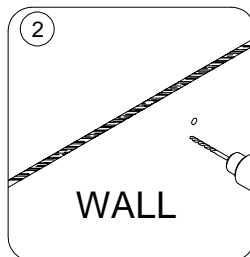

2. drill one Ø6 holes on the wall

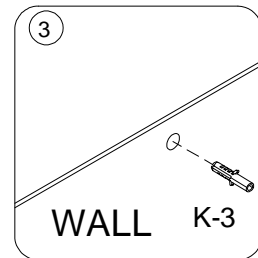

3. put one anchors in the holes

STEP20

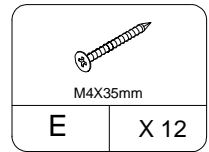
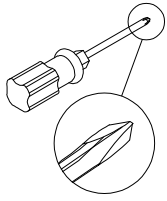

Ensure uniform groove direction during installation.

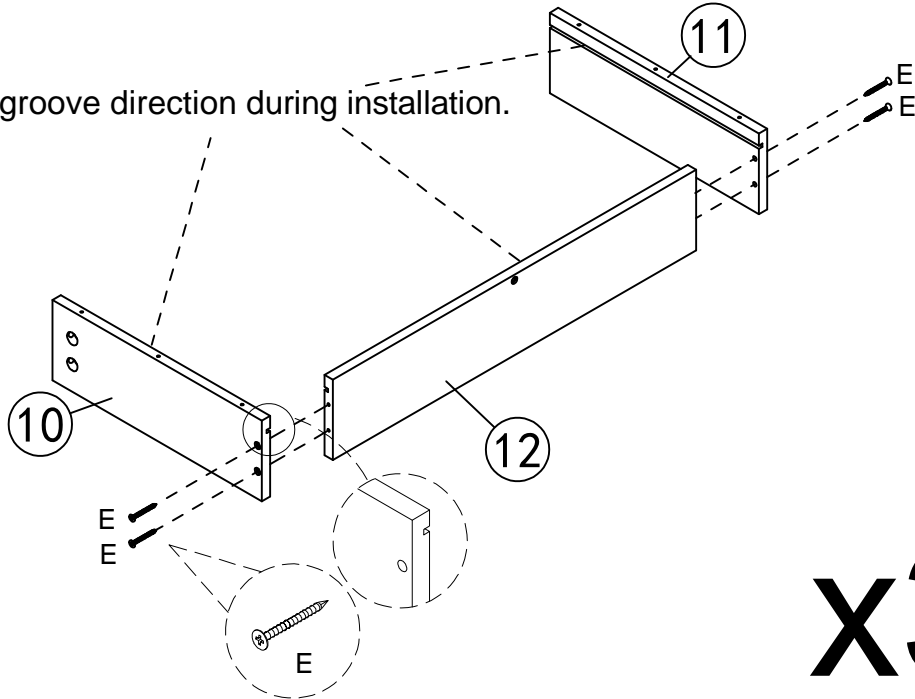

STEP21

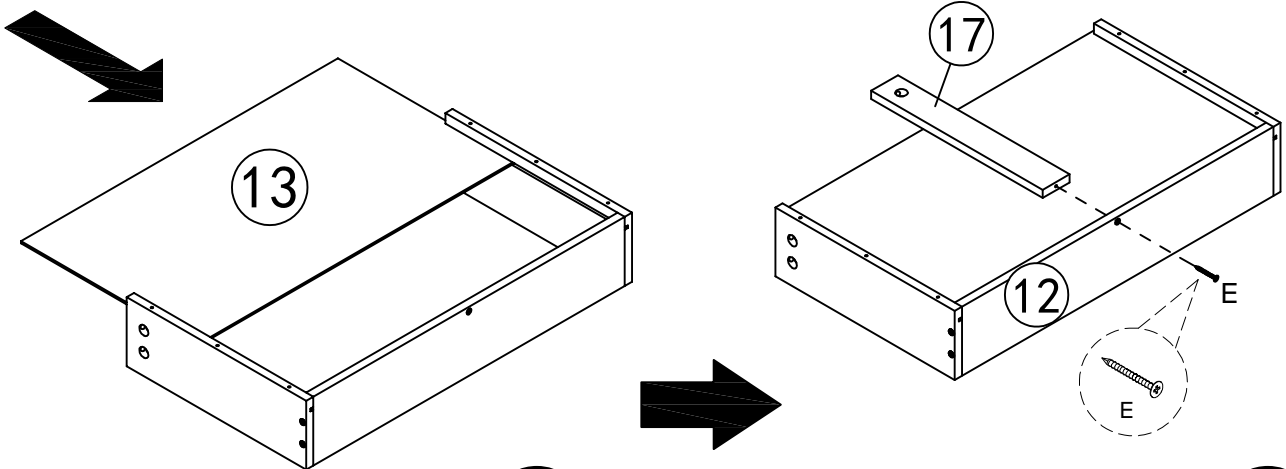
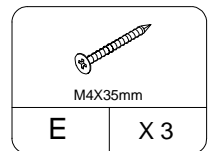
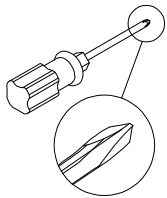

x3

x3

STEP22

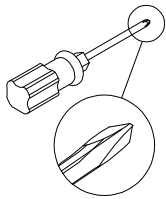

 M6X35mm	
B	X 15

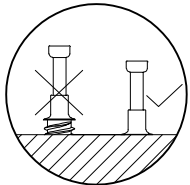
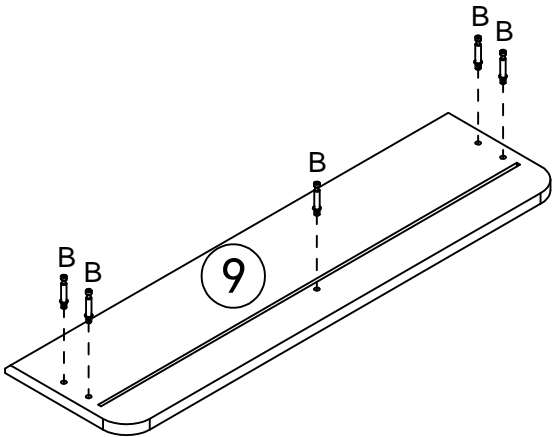
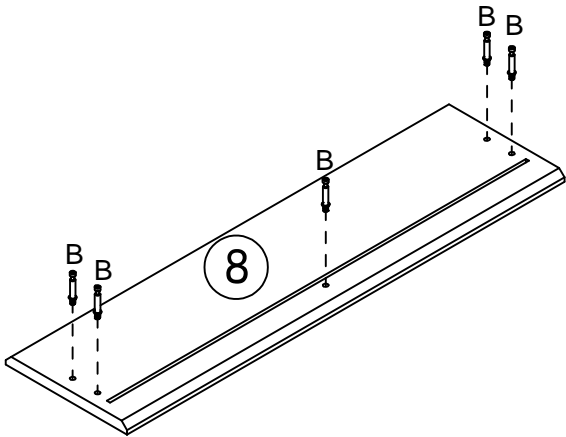
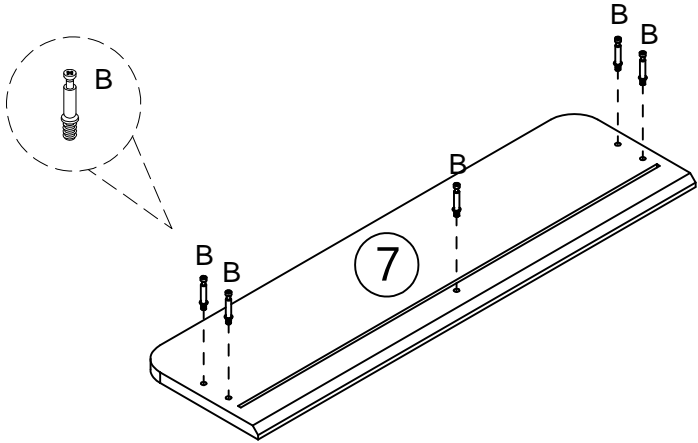

STEP23

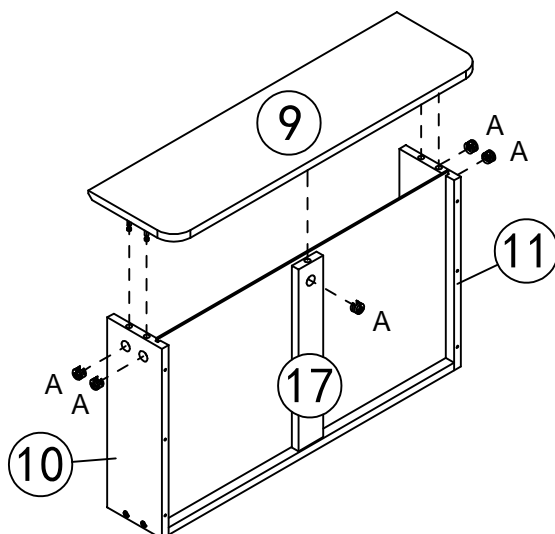
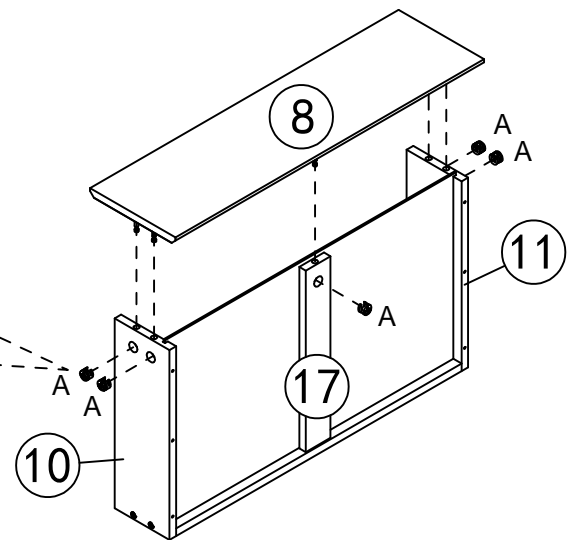
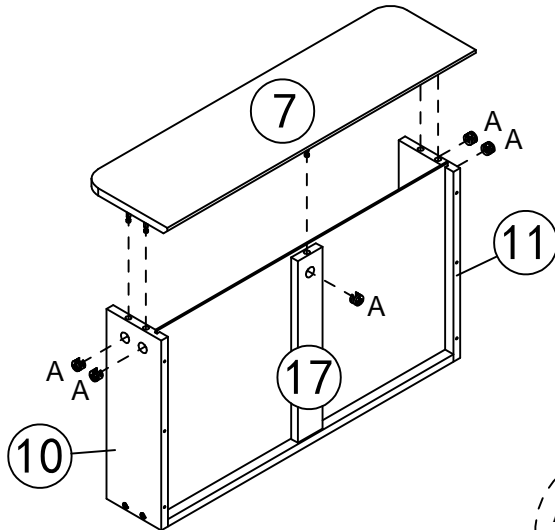
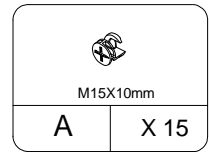
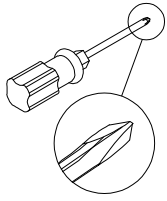

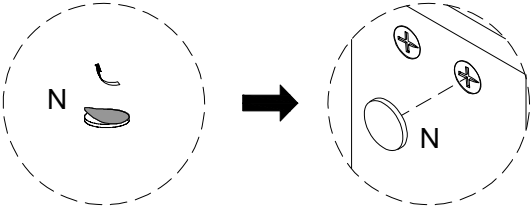
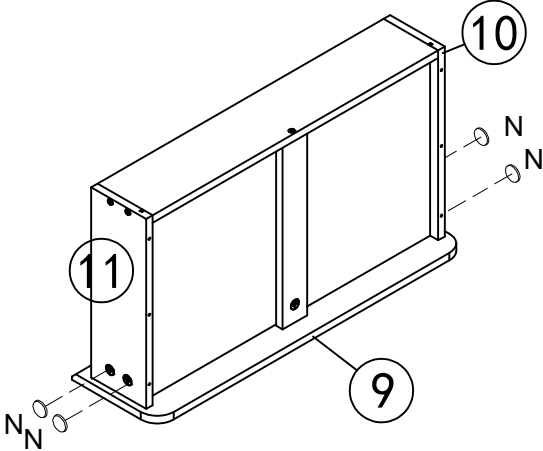
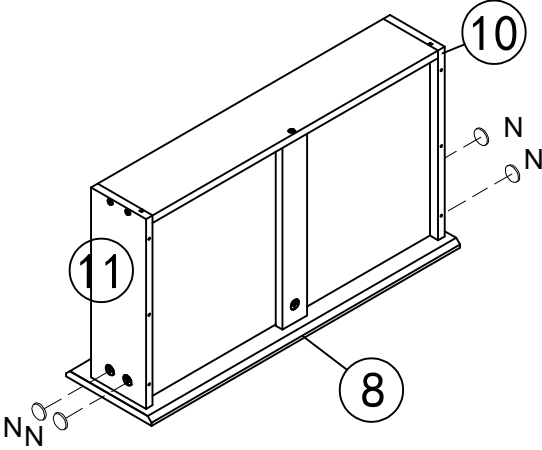
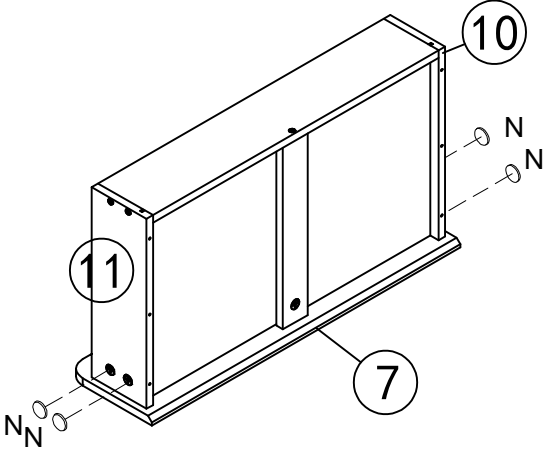
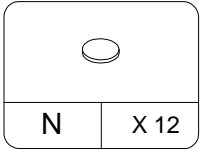

Insert the cam bolt into the hole first, then insert the cam lock and lock it.

STEP24

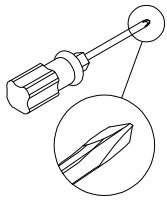

STEP25

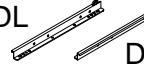

 M3.5X14mm	
D	X 18

 L 350mm	
DL	DR
G	X 3

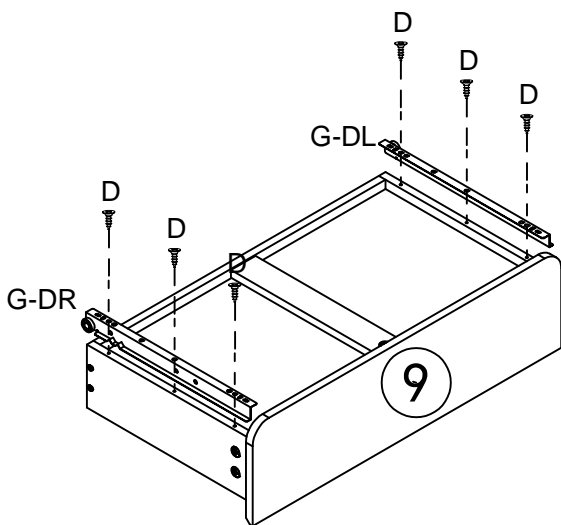
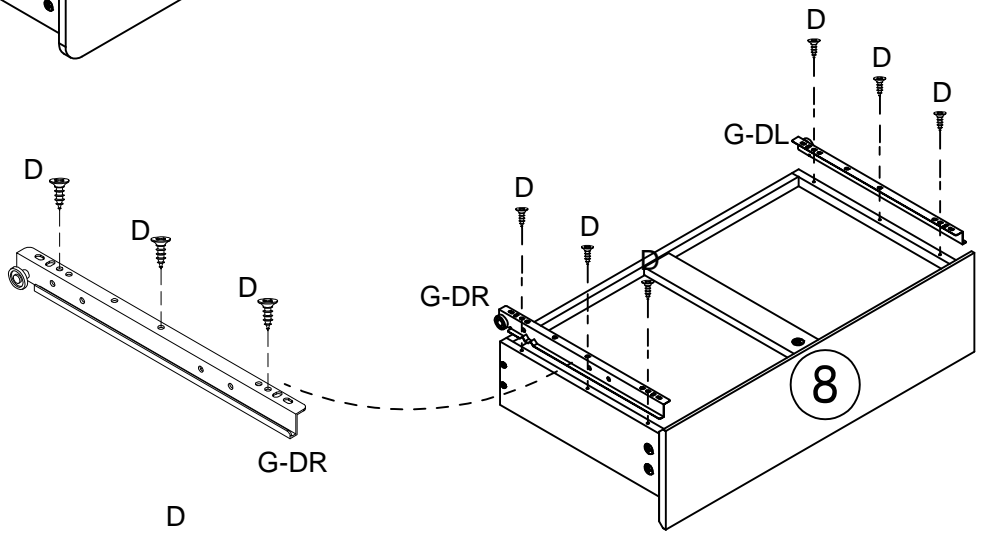
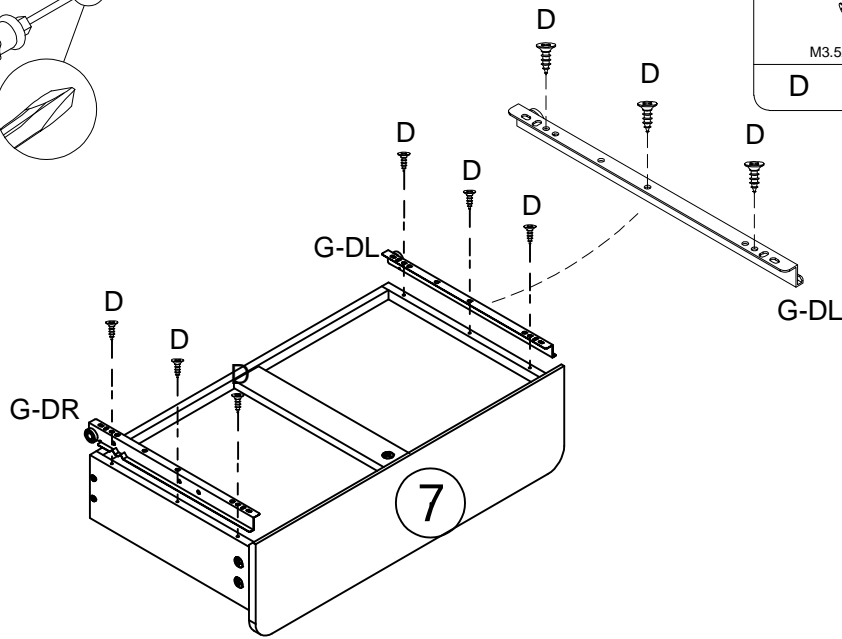

STEP26

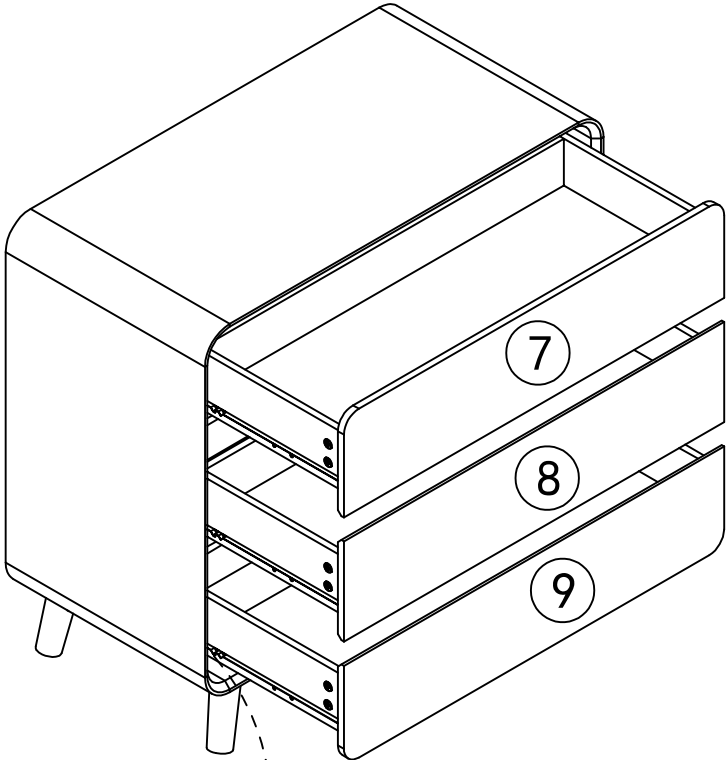

Cabinet Slide

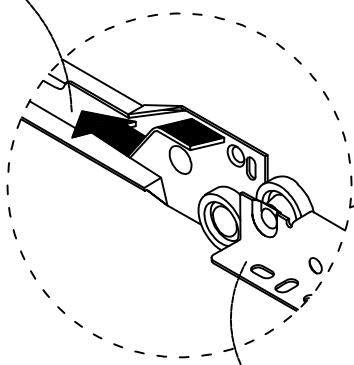

Drawer Slide