

# ASSEMBLY INSTRUCTIONS

## Bed 90 × 190

ITEM NUMBER:

N652P454822

N652P454823

N652P454824

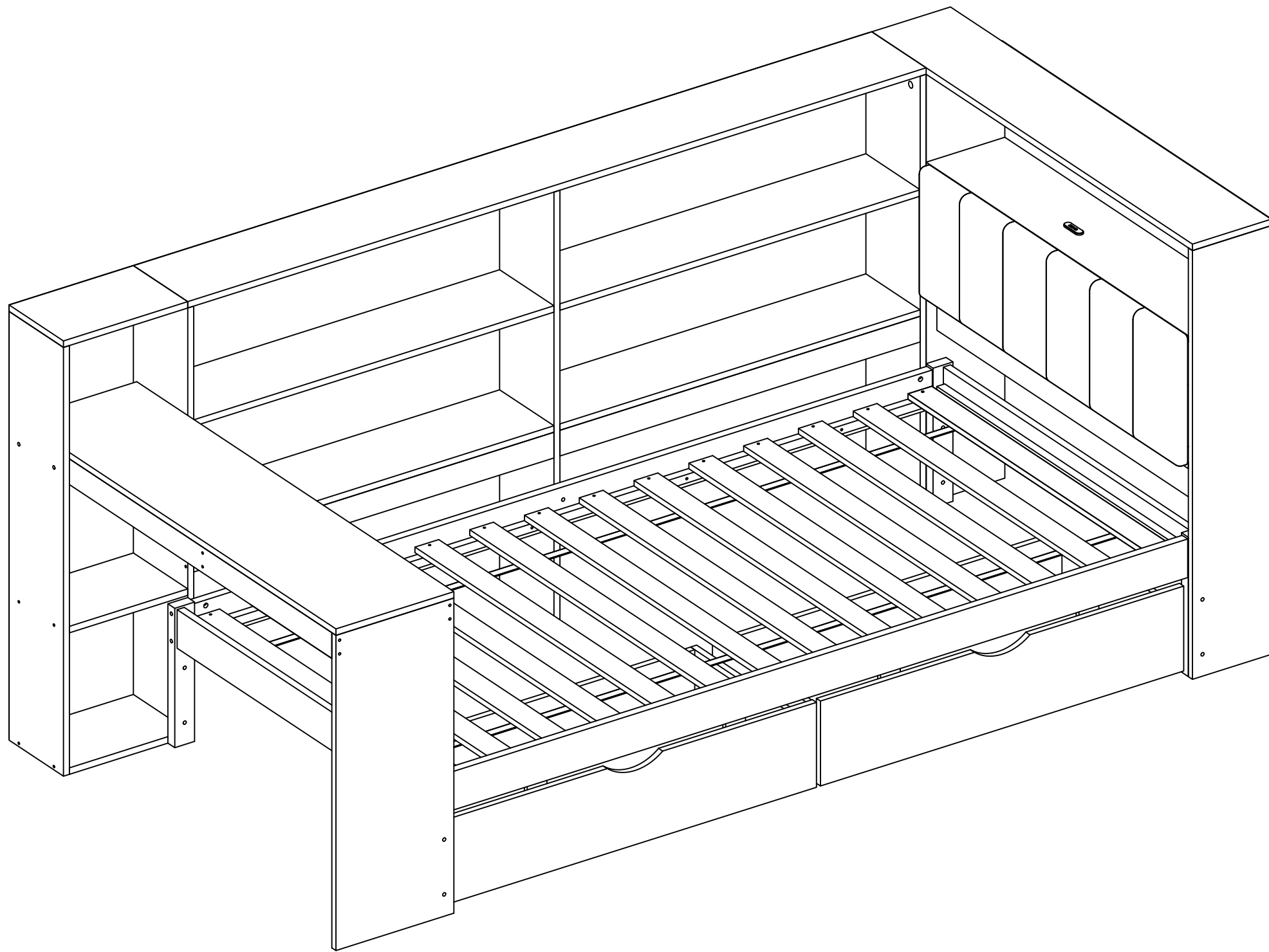

This set comes in 3 boxes. If you do not receive a full 3 boxes, please contact our customer service.

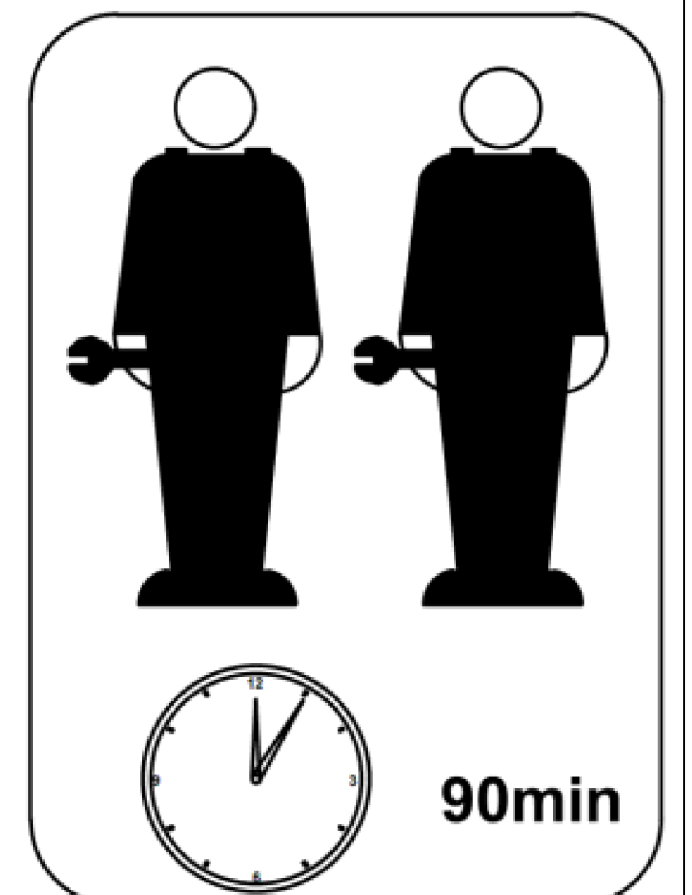

# INSTRUCTIONS

## IMPORTANT-READ CAREFULLY-RETAIN FOR FUTURE REFERENCE

- a) **WARNING** -Children can become trapped between the bed and the wall, the adjoining pieces of furniture (e.g. cupboards) and the like. To avoid risk of serious injury the distance between the safety barrier and the adjoining structure shall not exceed 90 mm or shall be more than 230 mm.
- b) **WARNING**-Do not use the bed if any structural part is broken or missing; Replacement parts are between requested from the manufacturer or the store.
- c) **WARNING**-Do not climb or wiggle on any non-designated structures.
- d) it is imperative to always follow the installation instructions and manufacturer's use.
- e) The recommended size of the mattress to be used with the bed is 190cmx90cm.
- f) It is necessary to ventilate the room in order to maintain a low level moisture and prevent mold growth in the bed and its periphery.
- g) Joining devices should always be tightened properly and regularly verified. Tighten if necessary.

English

IMPORTANT ! KEEP FOR FUTURE REFERENCE : READ CAREFULLY

- To be assembled by an adult. Assembly must be checked by an adult before use
- **WARNING !** Keep all screws, small parts and plastic bags out of the reach of children
- Properly identify all parts before assembling
- Never use your item if any of its parts are broken or missing
- Should any problems arise, please contact our After Sales Service
- Manufacturer's instructions shall be followed at all times
- Care: Clean with a soft, dry cloth. In case of larger stains, carefully rub with a slightly damp, non-abrasive sponge
- Avoid the risk of fire by not placing furniture near sources of ignition or hot items
- Do not jump on the bed

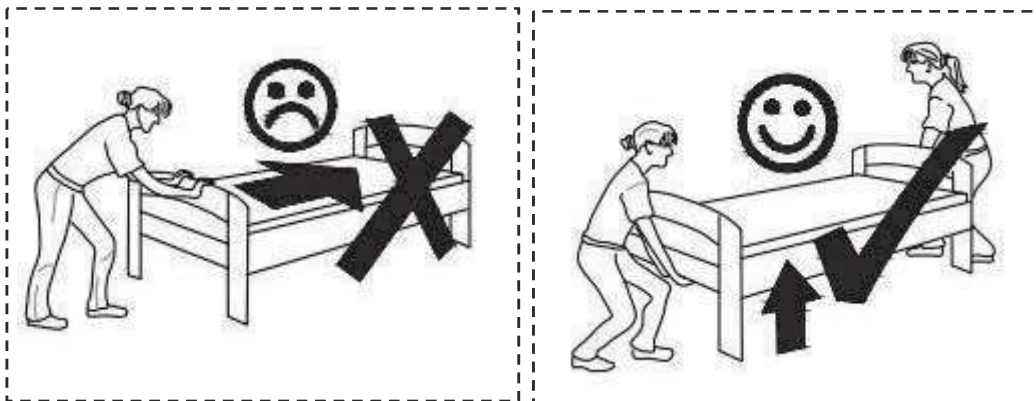

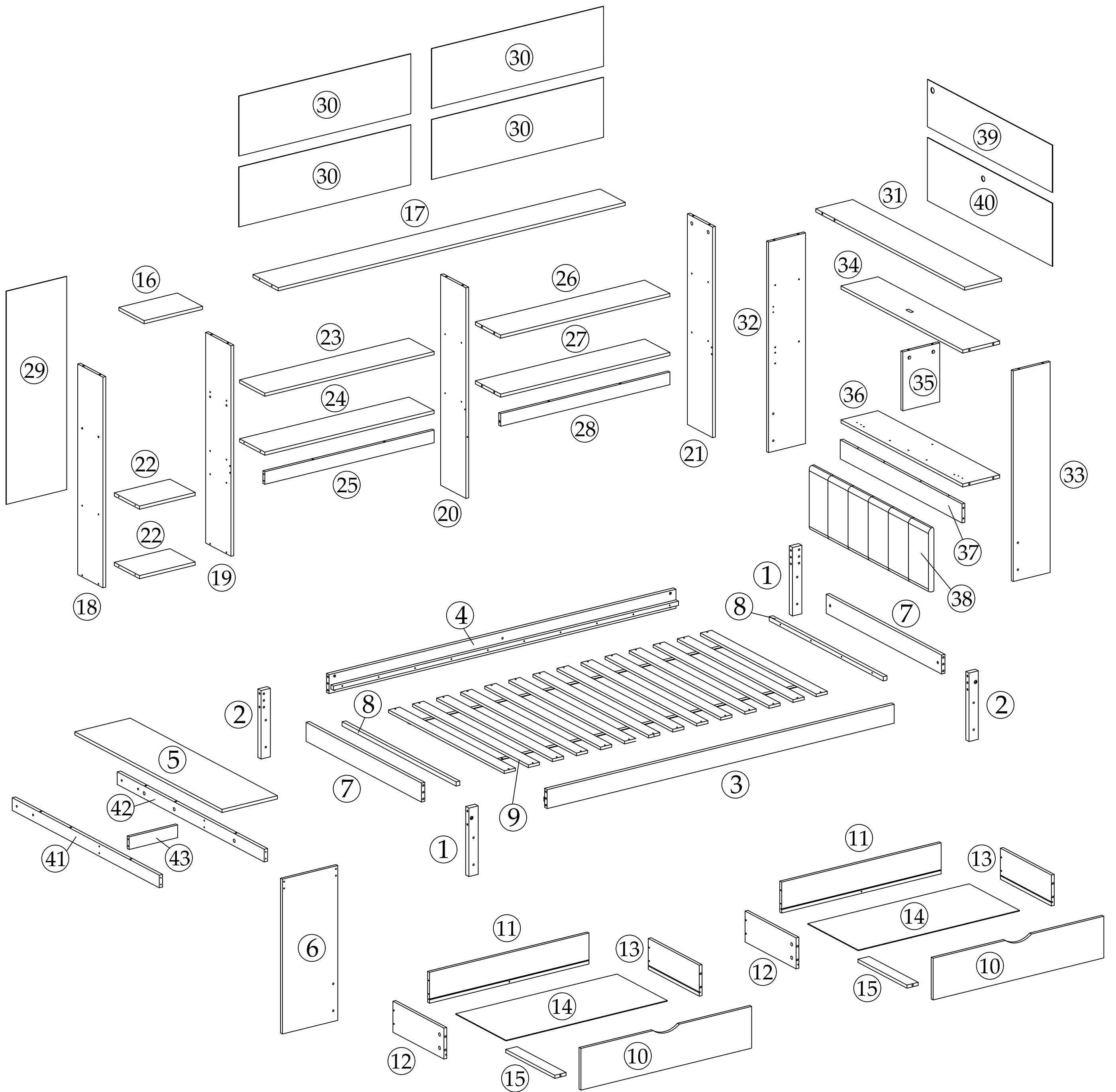

# ASSEMBLY INSTRUCTIONS



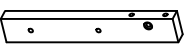
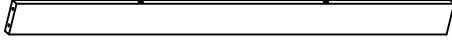
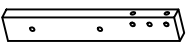
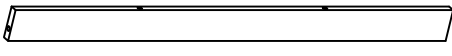
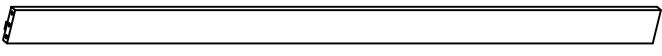
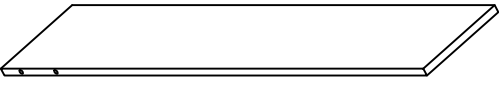

# ASSEMBLY INSTRUCTIONS

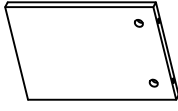
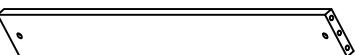
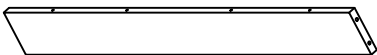
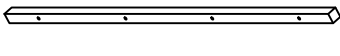
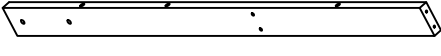
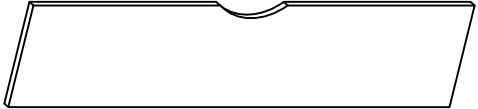
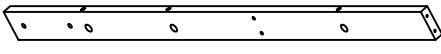
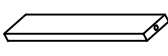
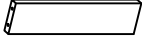
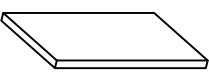
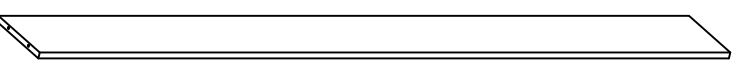
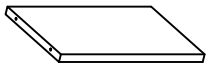
## N652P454822

1		2PCS	25		1PC
2		2PCS	28		1PC
3		1PC	31		1PC
4		1PC	35		1PC
7		2PCS	37		1PC
8		2PCS	41		1PC
10		2PCS	42		1PC
15		2PCS	43		1PC
16		1PC			
17		1PC			
22		2PCS			



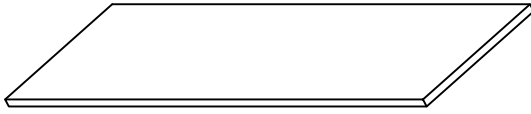
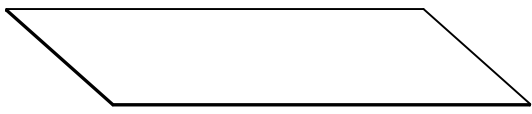
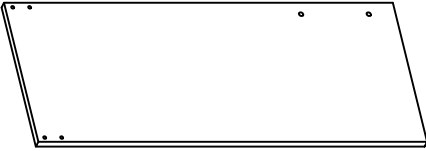
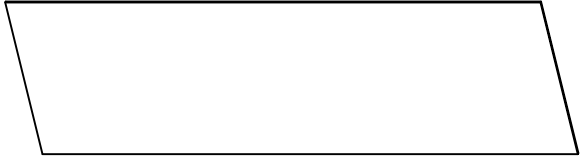
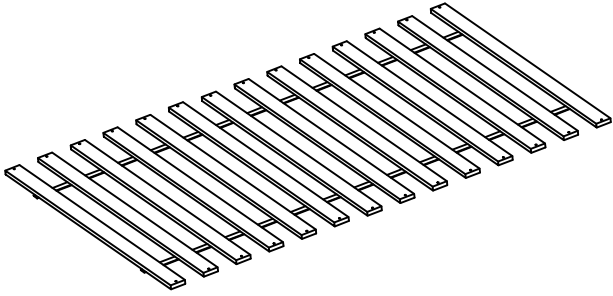

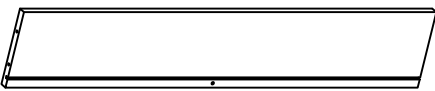
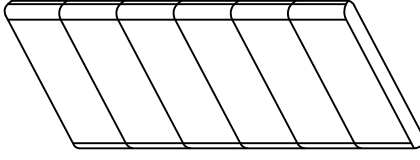
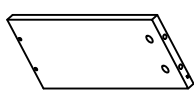
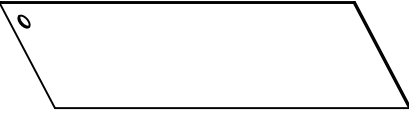
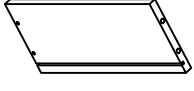
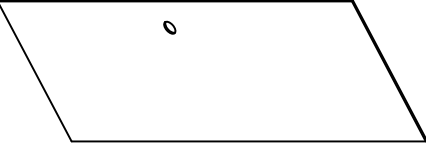



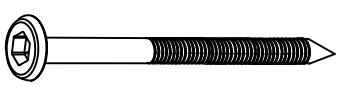
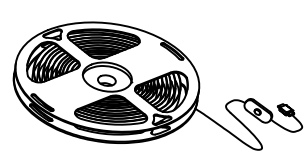
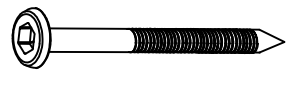

# ASSEMBLY INSTRUCTIONS

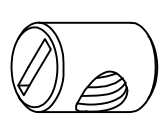
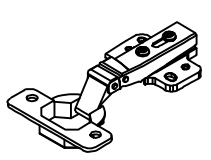
## N652P454823

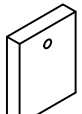
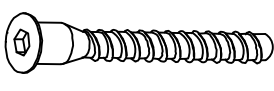
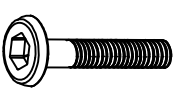
5		1PC	14		2PCS
6		1PC	29		1PC
9		1PC	30		4PCS
11		2PCS	38		1PC
12		2PCS	39		1PC
13		2PCS	40		1PC
Hardware box		1PC			

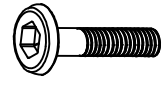
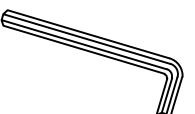
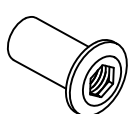
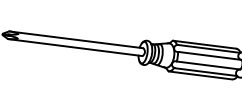
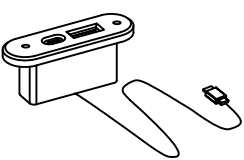
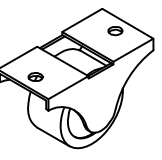
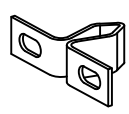
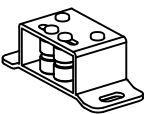
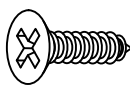
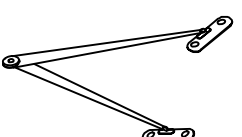
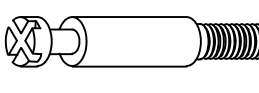
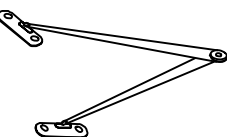

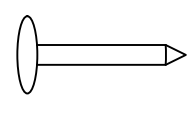
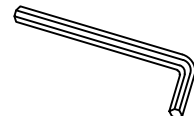
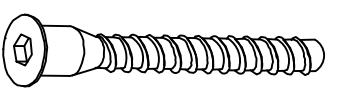

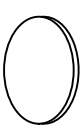
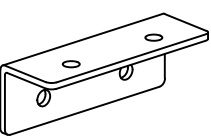
# ASSEMBLY INSTRUCTIONS

## N652P454823 — Hardware box

A	6x90		8PCS	P			1PC
B	6x70		4PCS	Q			3PCS
C			12PCS	R			2PCS
D	8x30		14PCS	S			4PCS
E	5x40		48PCS	T	6x30		6PCS
F	4x25		34PCS	U	6x25		4PCS
G	M3		1PC	V	8x20		10PCS
H			1PC	W			1PC
I			8PCS	X		 	1PC
J	3x14		65PCS	Y			1PC
K			56PCS	Z			1PC
L			56PCS	A1			40PCS
M	M4		2PCS	A2	7x60		1PC
N	4x30		8PCS	A3			10PCS
O			2PCS				

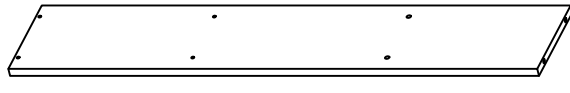
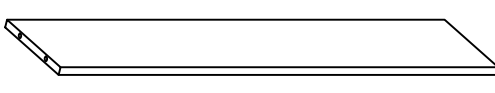
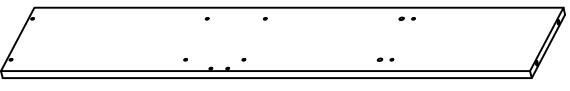
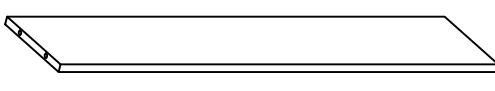
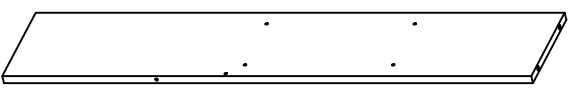
# ASSEMBLY INSTRUCTIONS

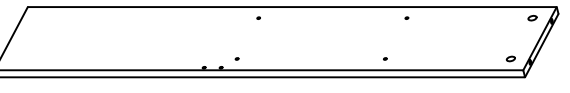
N652P454824

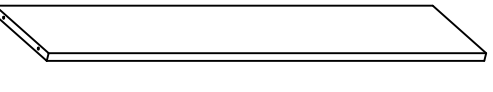
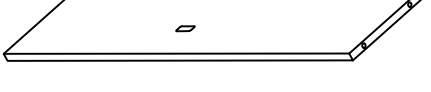
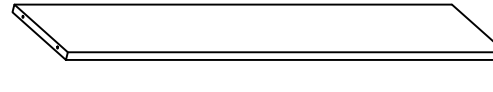
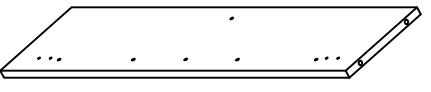
18		1PC	26		1PC
19		1PC	27		1PC
20		1PC	32		1PC
21		1PC	33		1PC
23		1PC	34		1PC
24		1PC	36		1PC

# ASSEMBLY INSTRUCTIONS

# 1

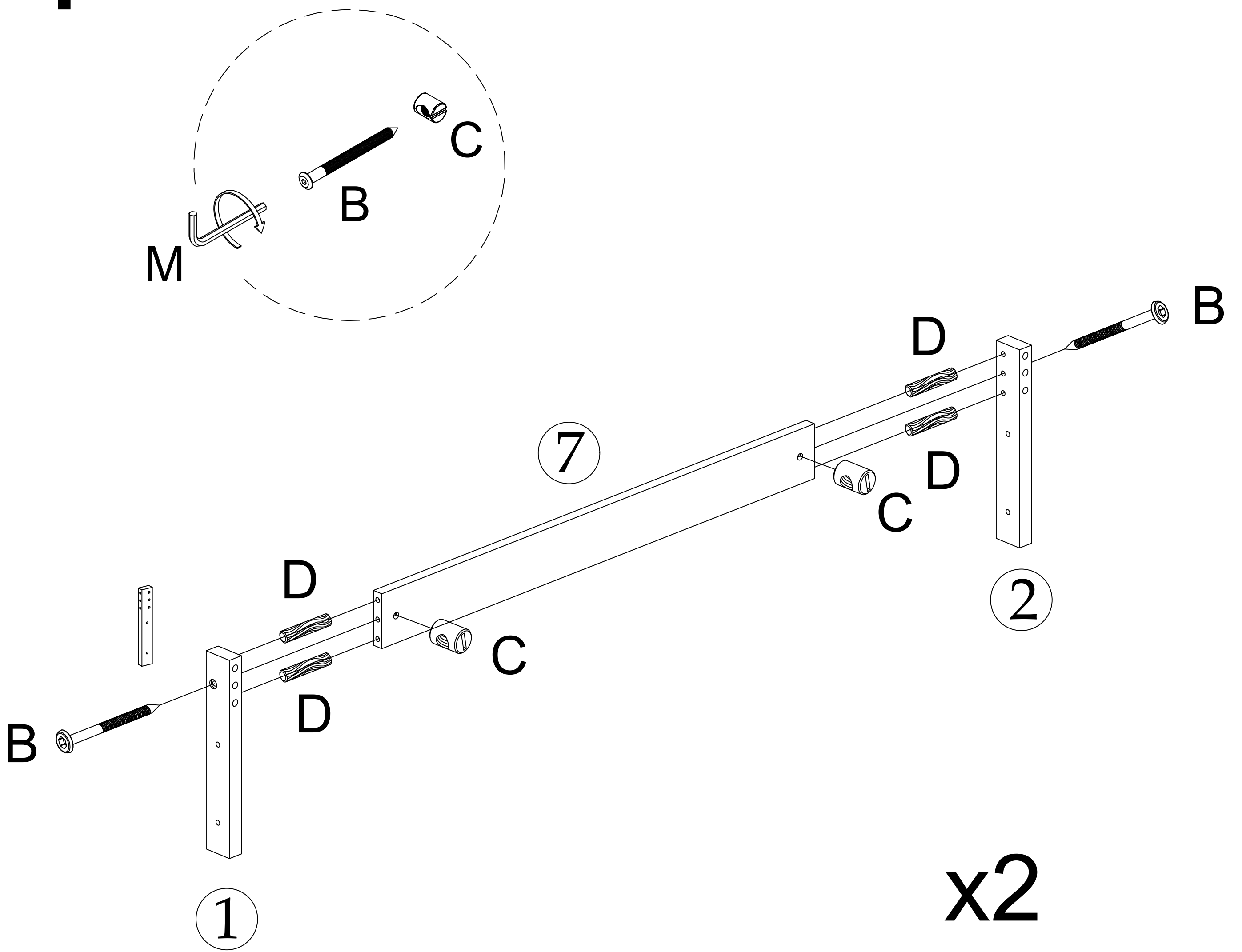

x2

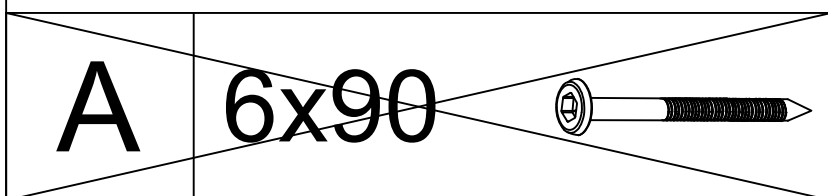



B	6x70		4PCS	D	8x30		8PCS
C			4PCS	M	M4		1PC

# ASSEMBLY INSTRUCTIONS

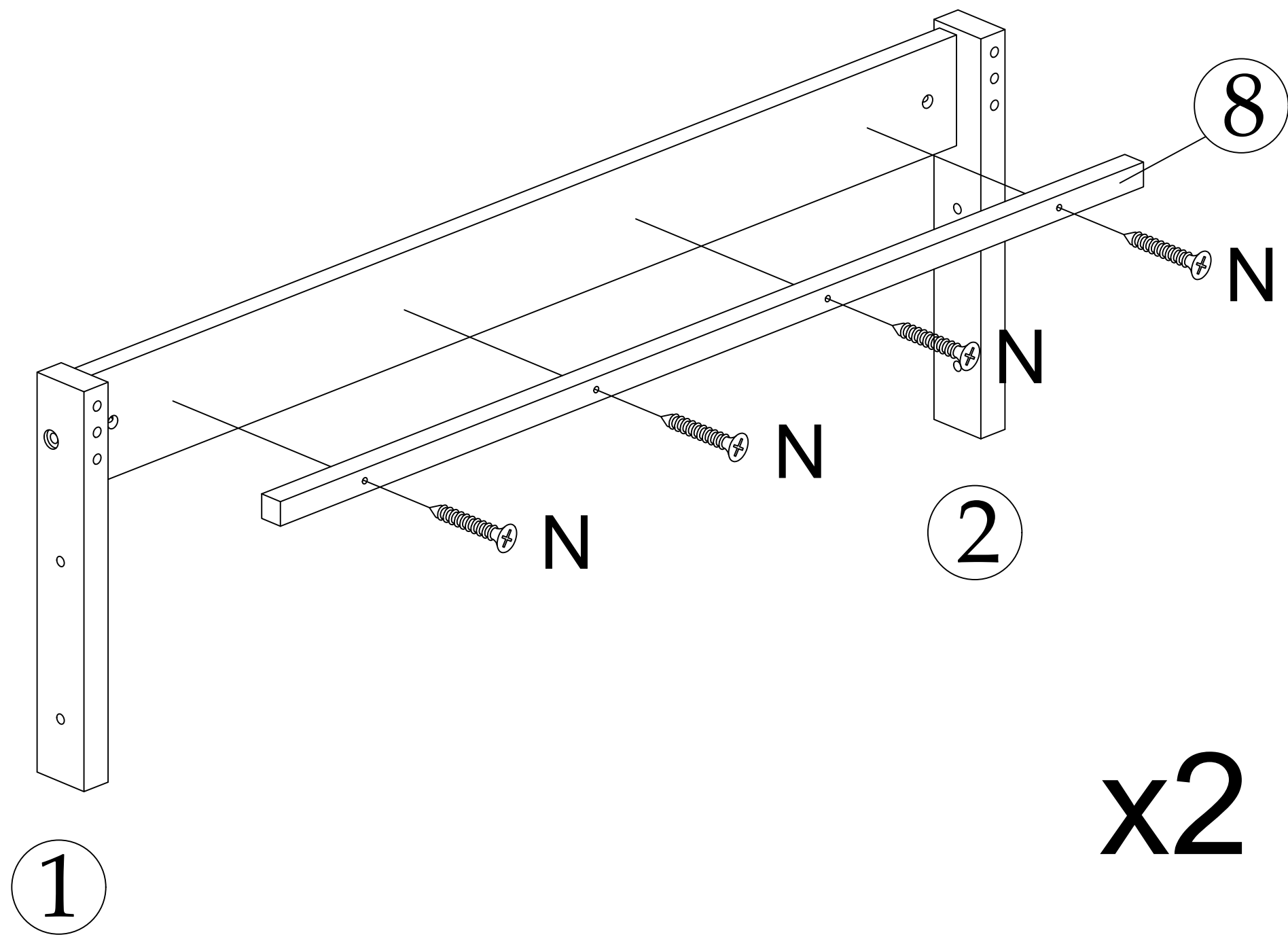
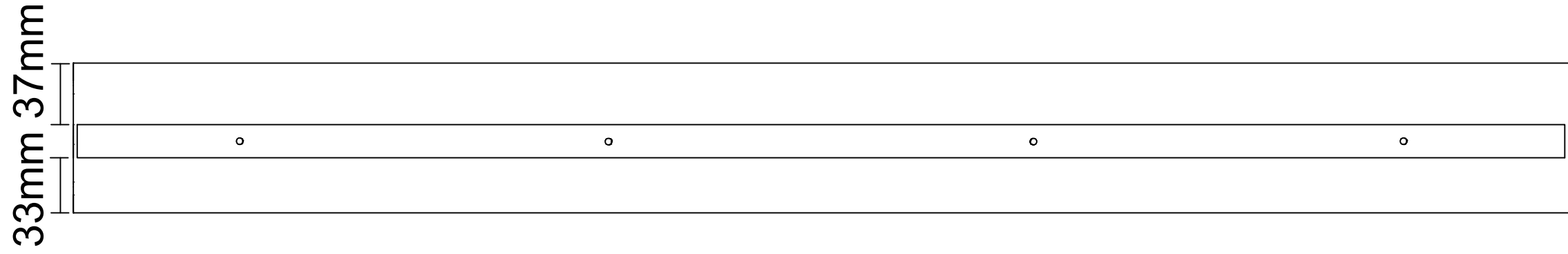
# 2



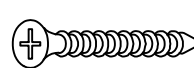

<del>J</del>	<del>3x14</del>	<del></del>
<del>F</del>	<del>4x25</del>	<del></del>

N	4x30		8PCS
---	------	---	------

# ASSEMBLY INSTRUCTIONS

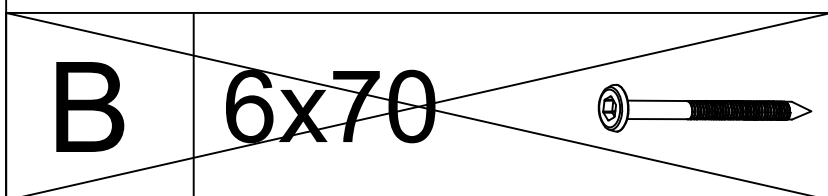
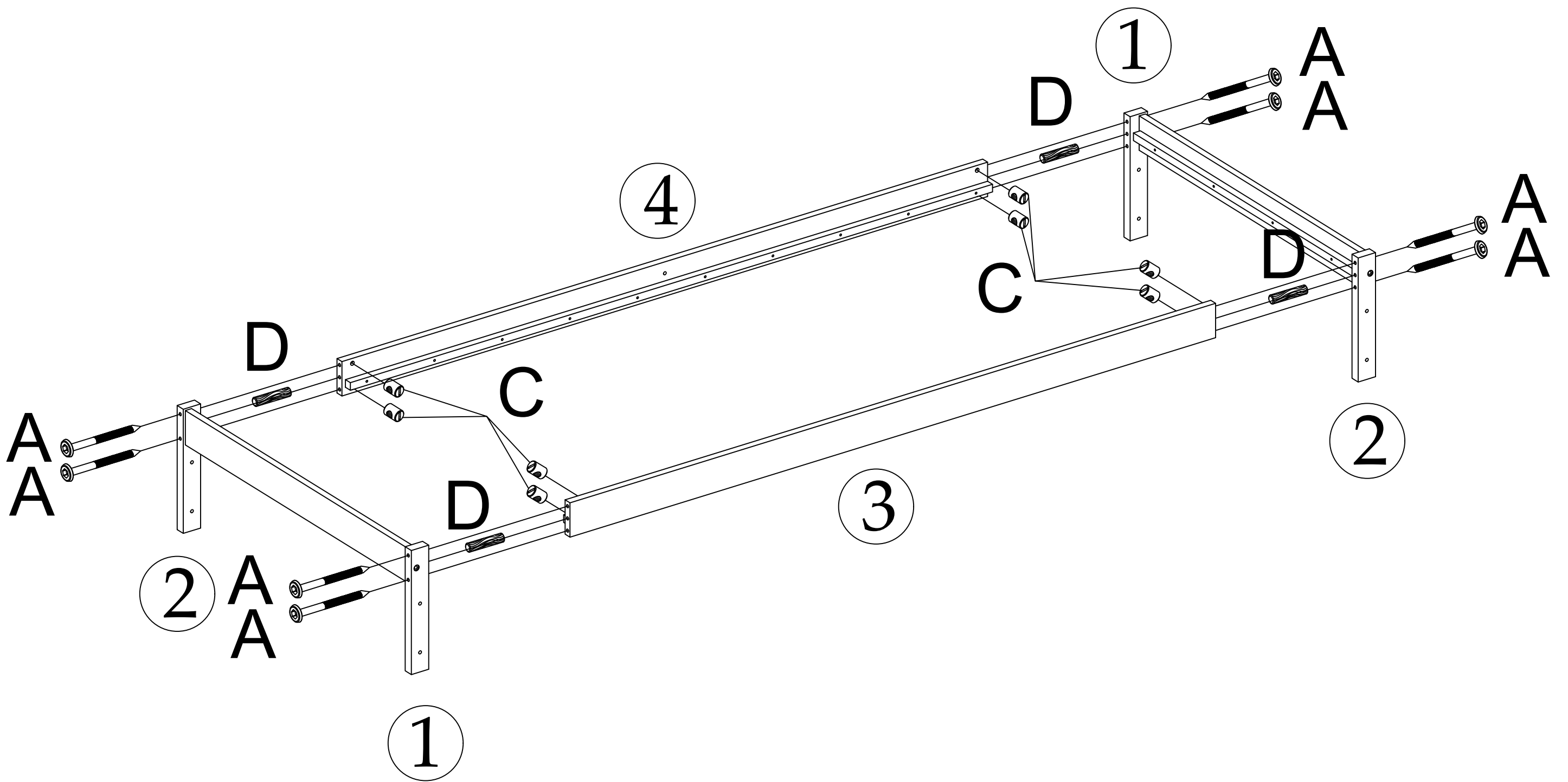
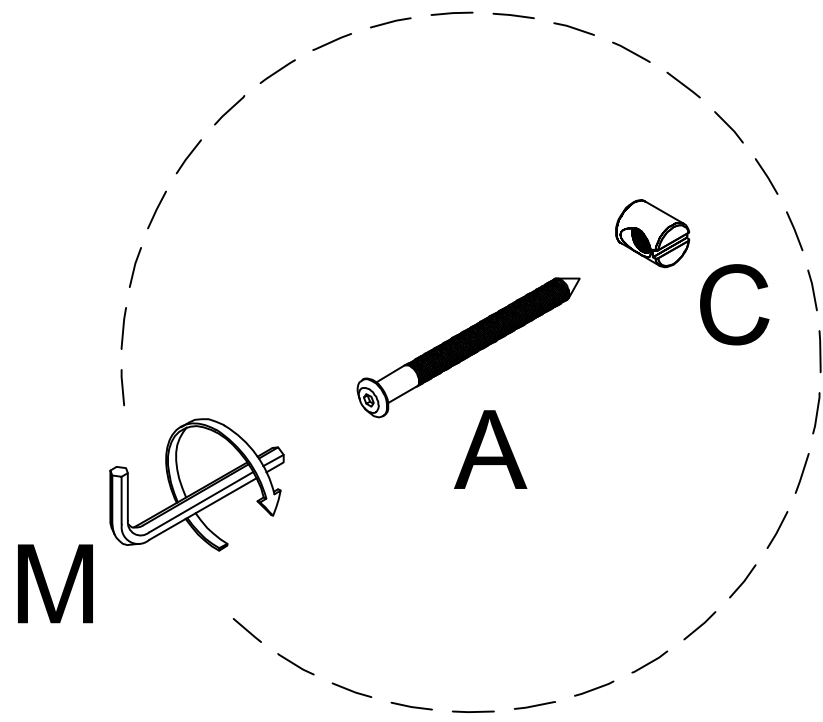
## 3

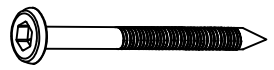

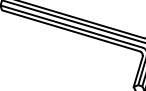
A	6x90		8PCS	D	8x30		4PCS
C			8PCS	M	M4		1PC

# ASSEMBLY INSTRUCTIONS

# 4

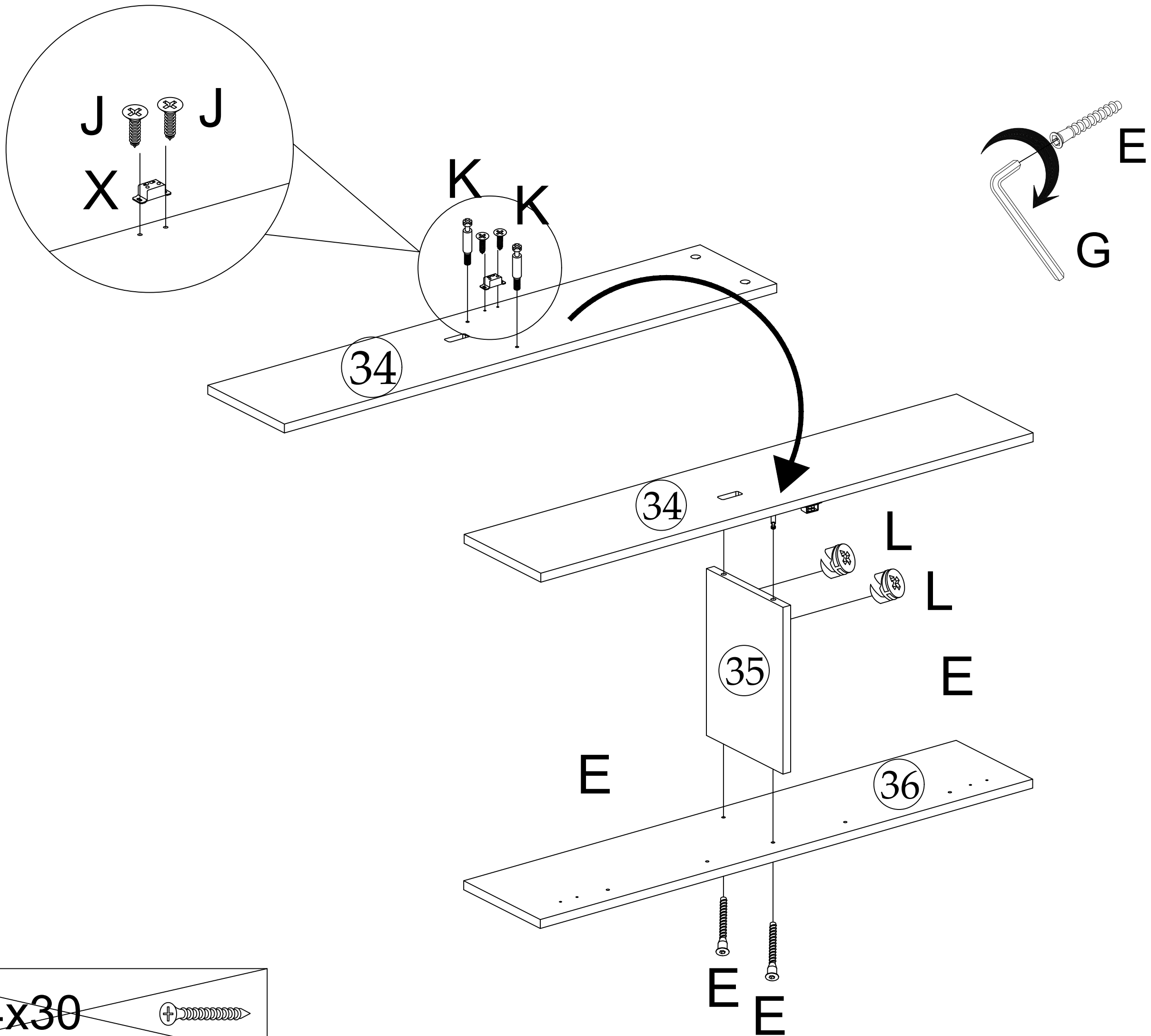
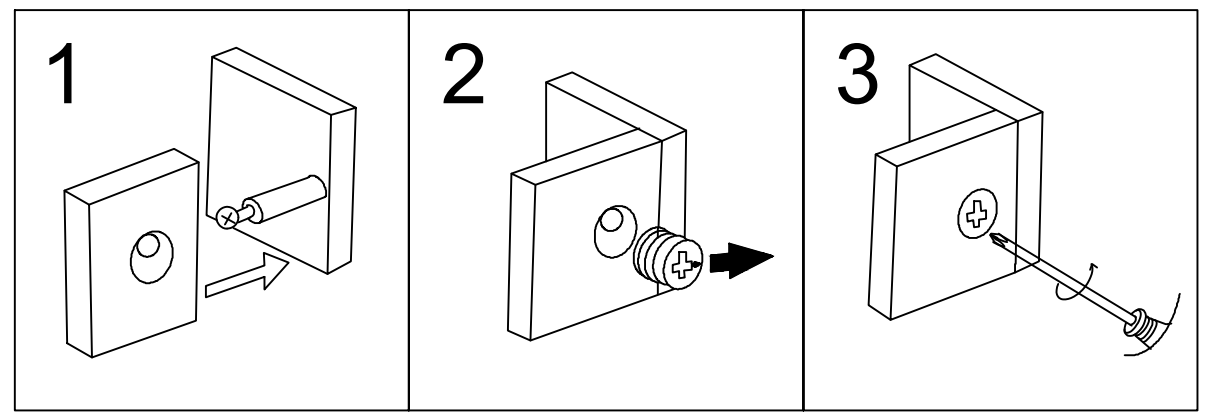

N	4x30	
F	4x25	



A2	7x60	
----	------	--

J	3x14		2PCS	E	5x40		2PCS
K			2PCS	G	M3		1PC
L			2PCS	X			1PC
H			1PC				

# ASSEMBLY INSTRUCTIONS

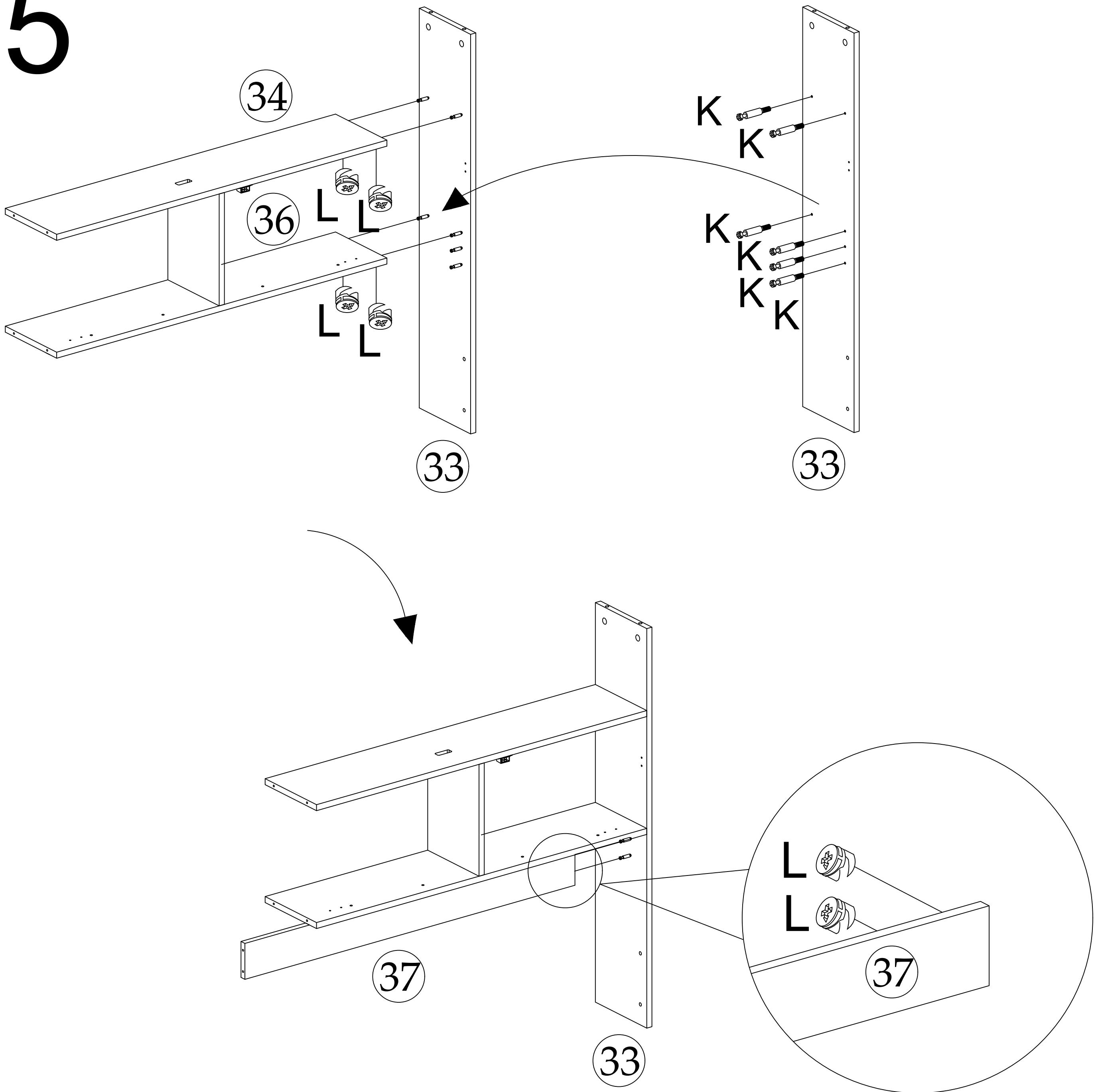
## 5

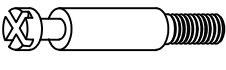

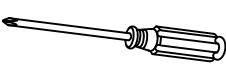
K		6PCS
L		6PCS
H		1PC

# ASSEMBLY INSTRUCTIONS

## 6

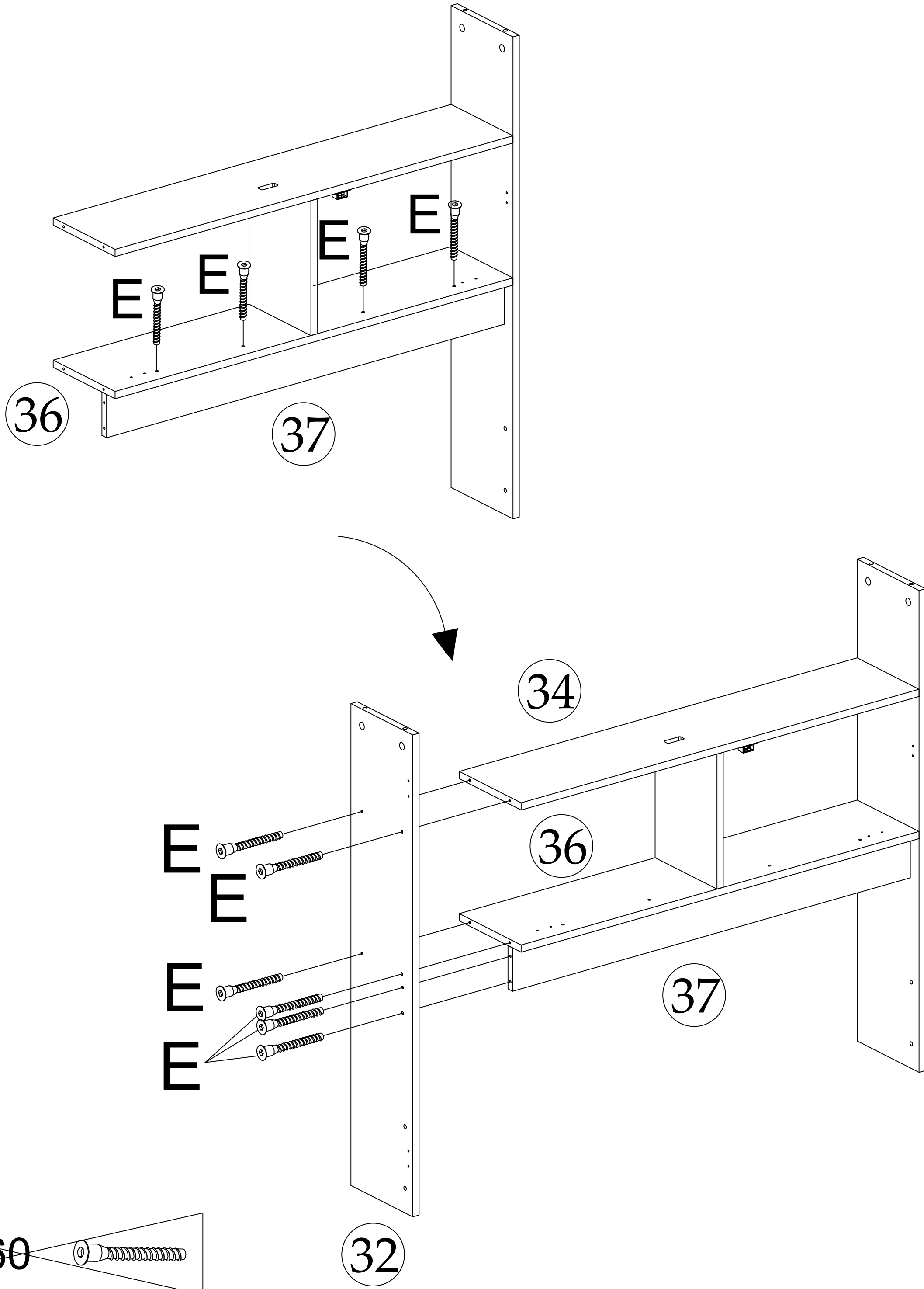

A2 7x60

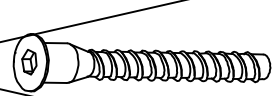

32

E 5x40 10PCS



G M3 1PC

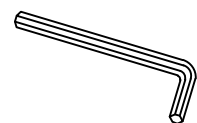

# ASSEMBLY INSTRUCTIONS

# 7

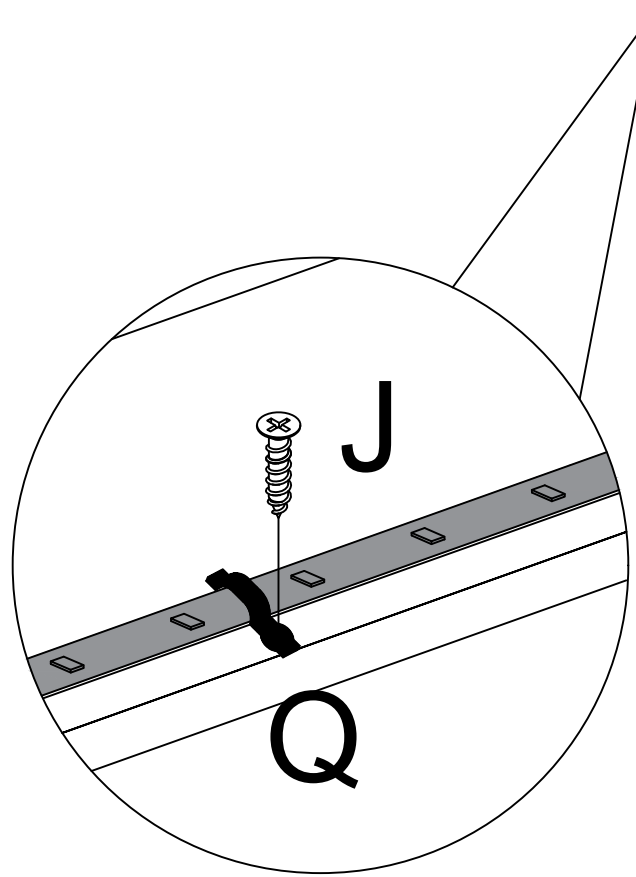
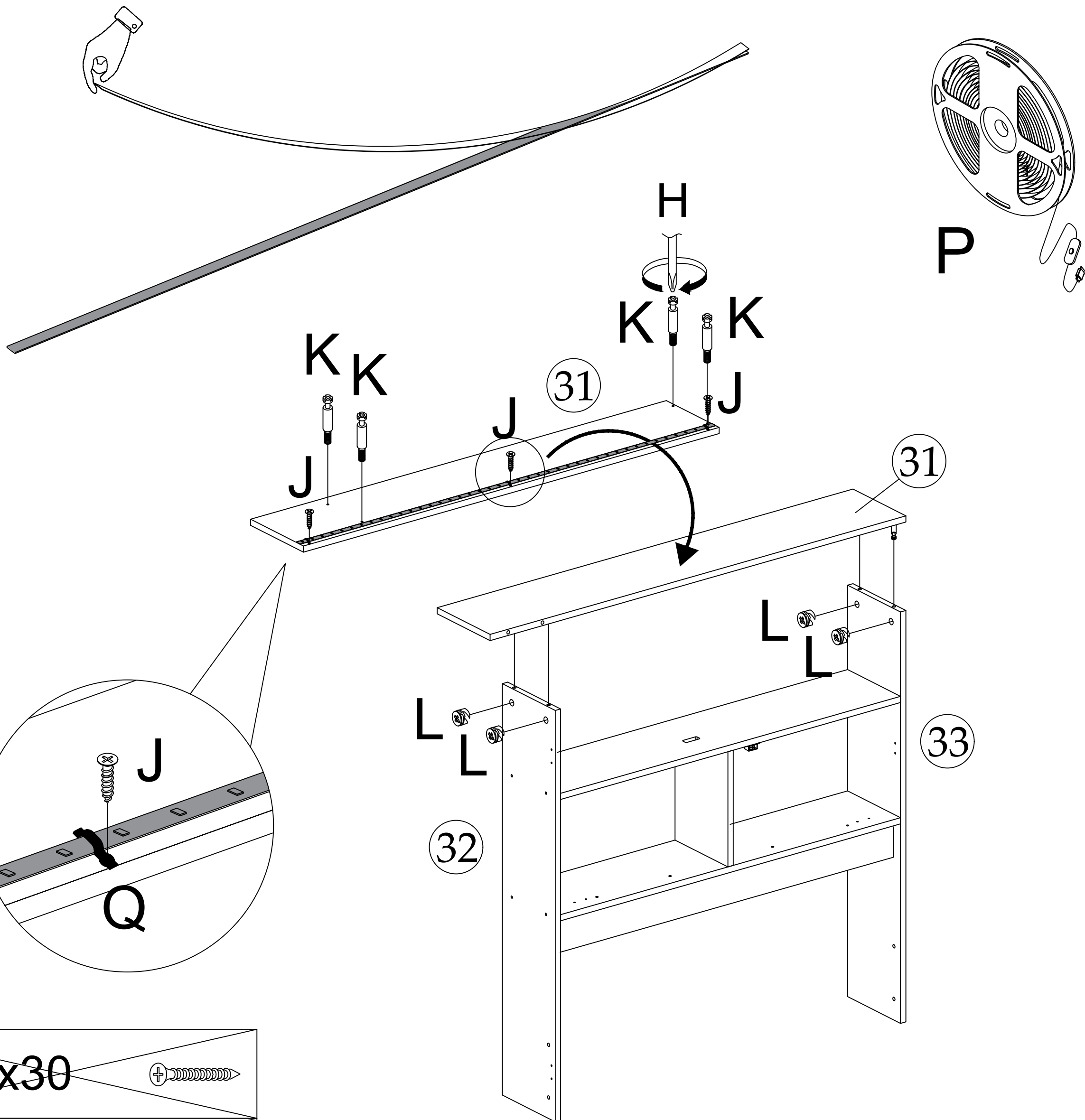
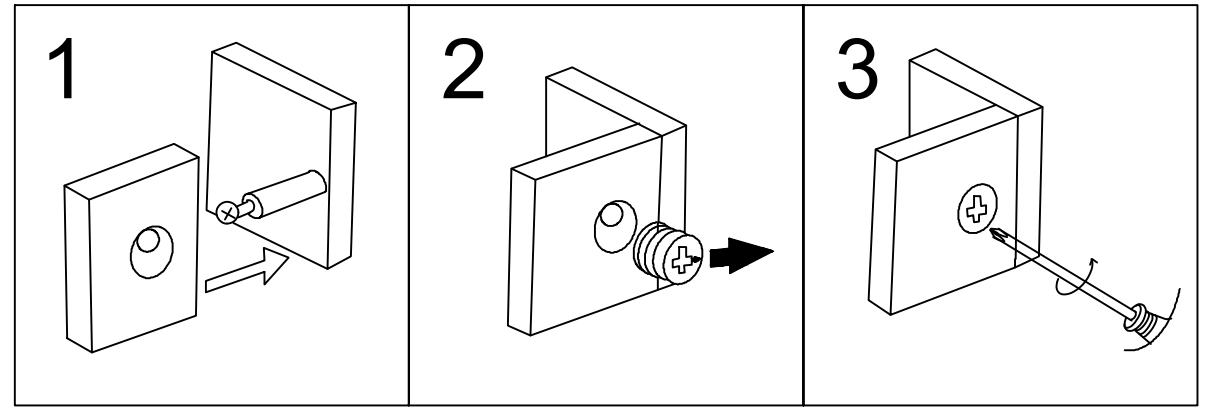

N	4x30	
F	4x25	

J	3x14		3PCS	K		4PCS
P			1PC	L		4PCS
Q			3PCS	H		1PC

# ASSEMBLY INSTRUCTIONS

## 8

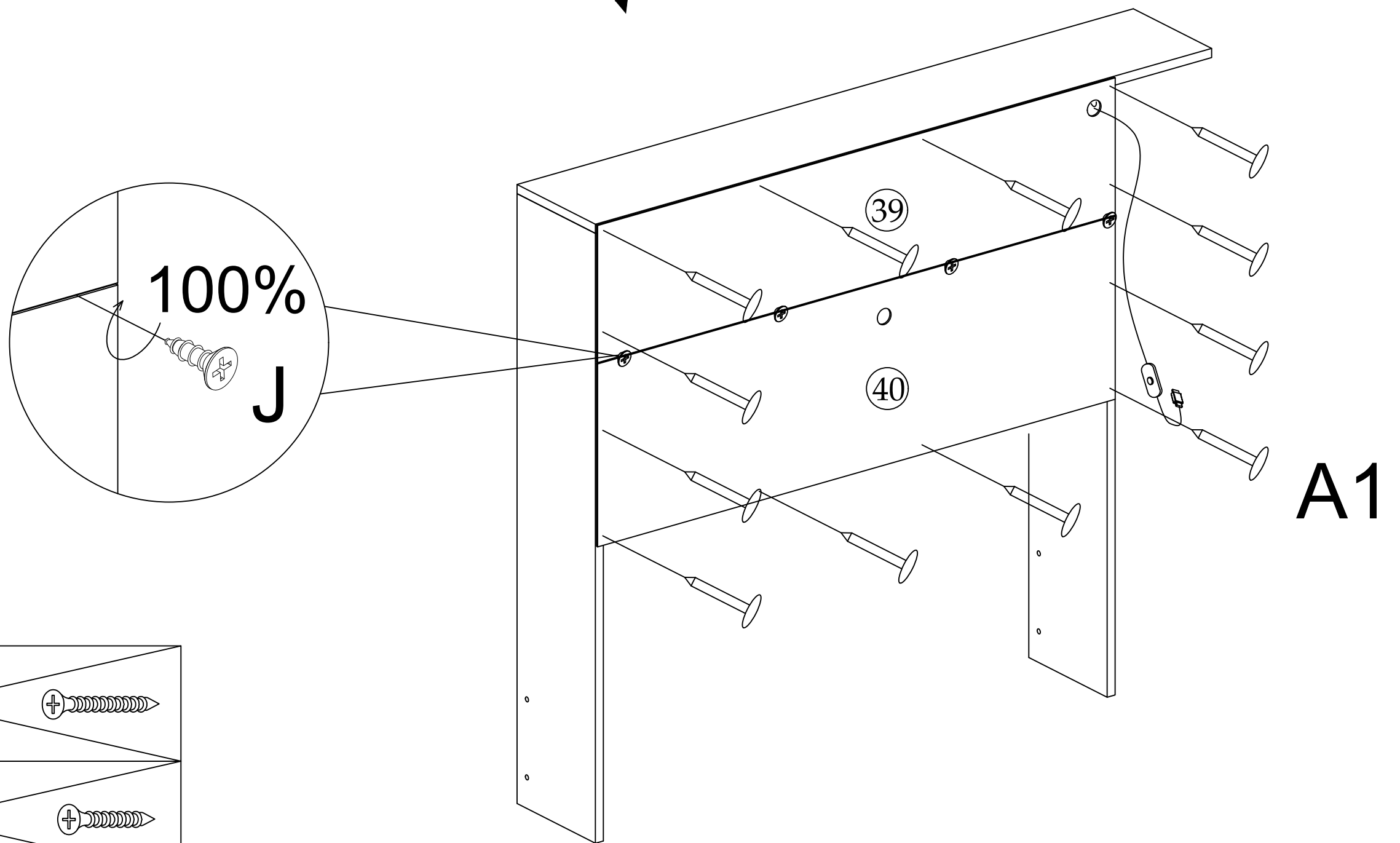
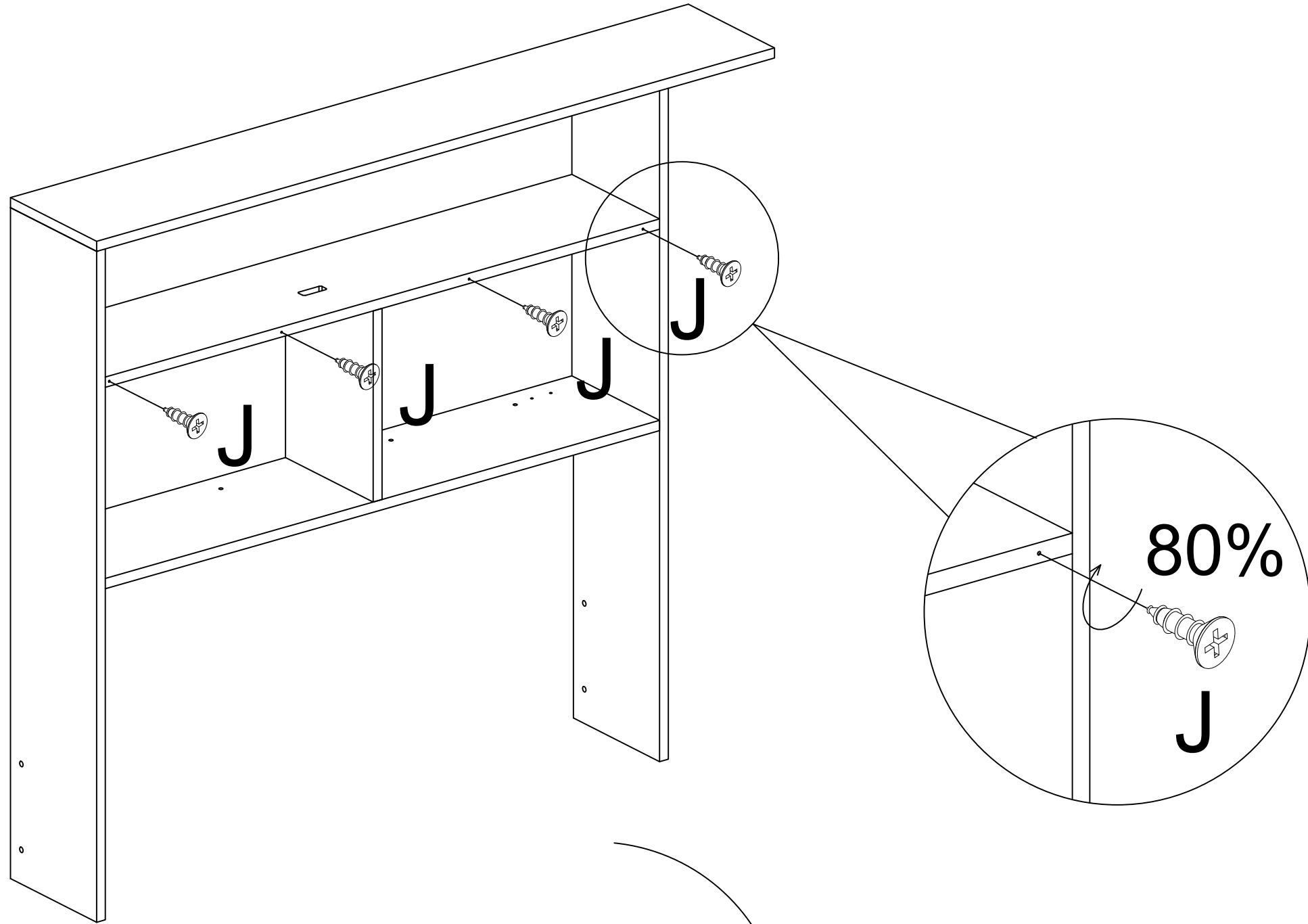

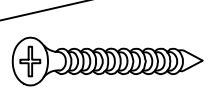
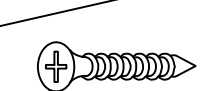
N	4x30	
F	4x25	

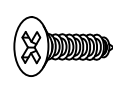
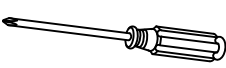
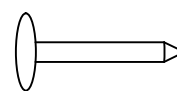
J	3x14		4PCS			
H			1PC	A1		12PCS

# ASSEMBLY INSTRUCTIONS

## 9

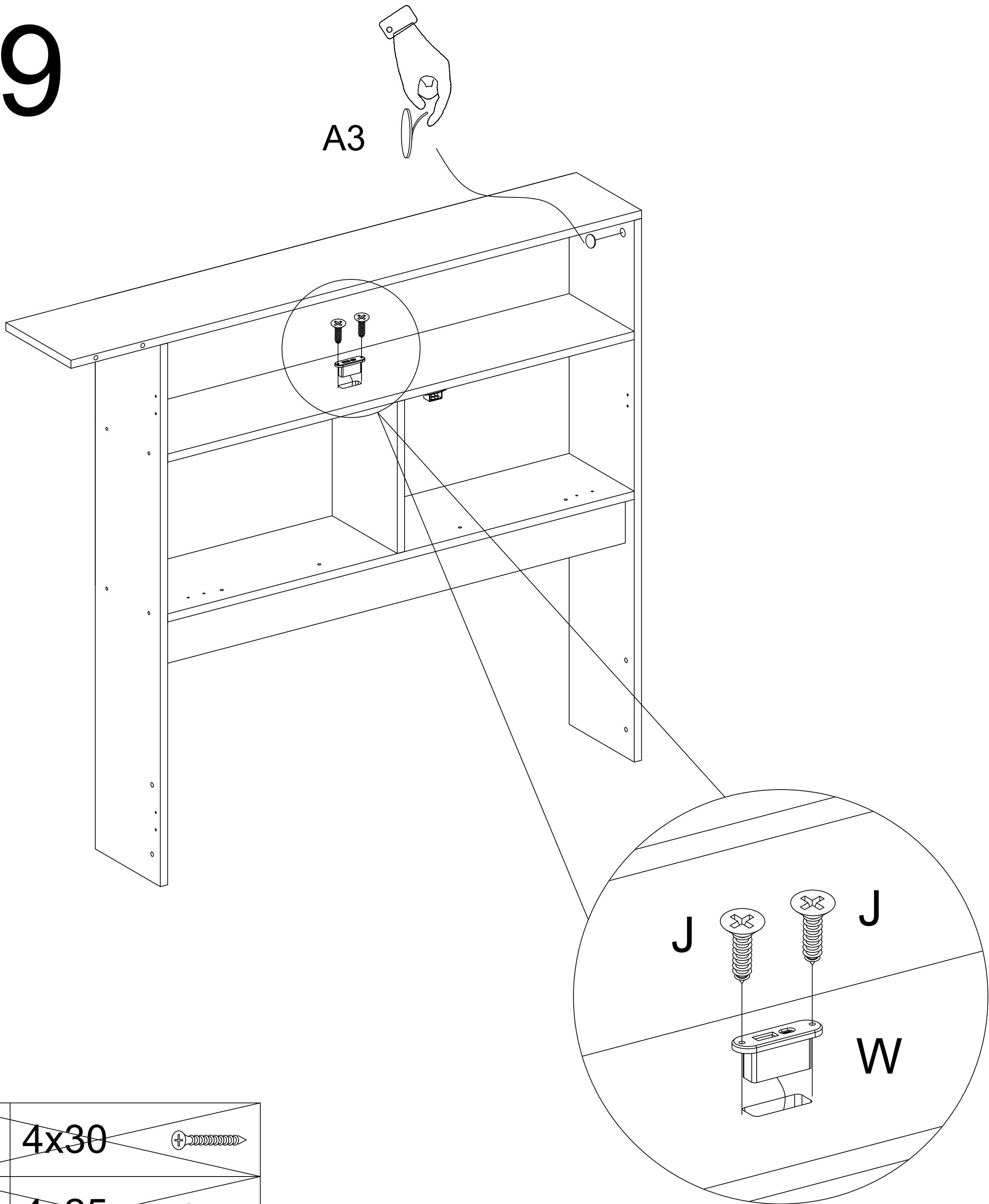

N	4x30	
F	4x25	

J	3x14		2PCS	A3		2PCS
H			1PC	W		1PC

# ASSEMBLY INSTRUCTIONS

# 10

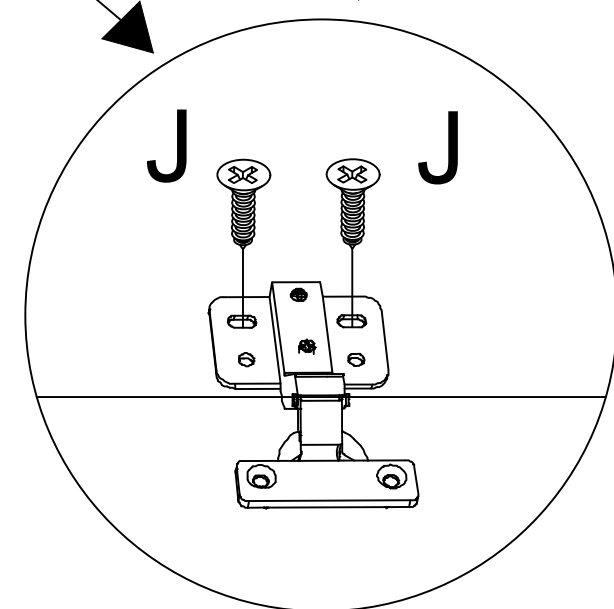
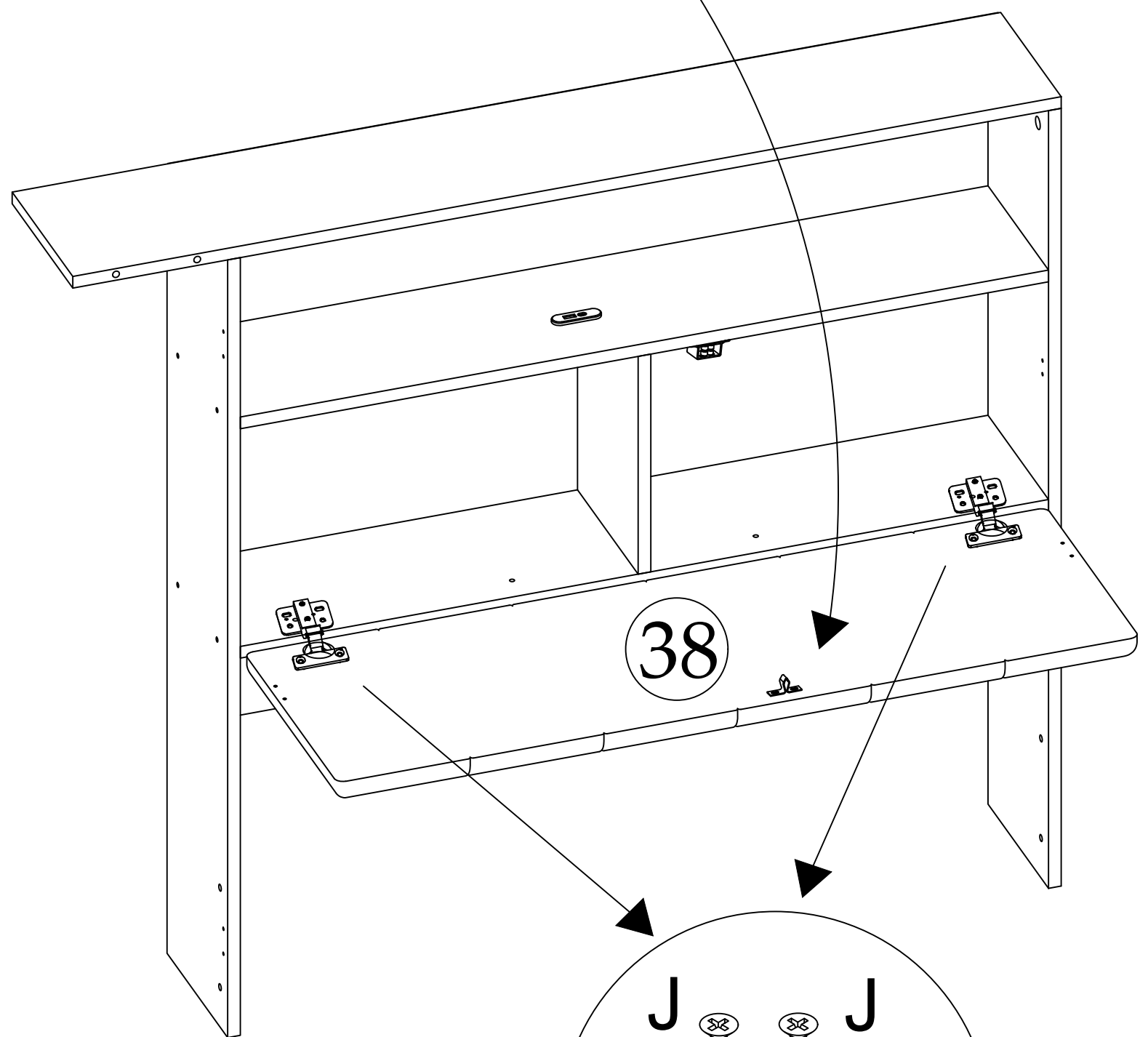
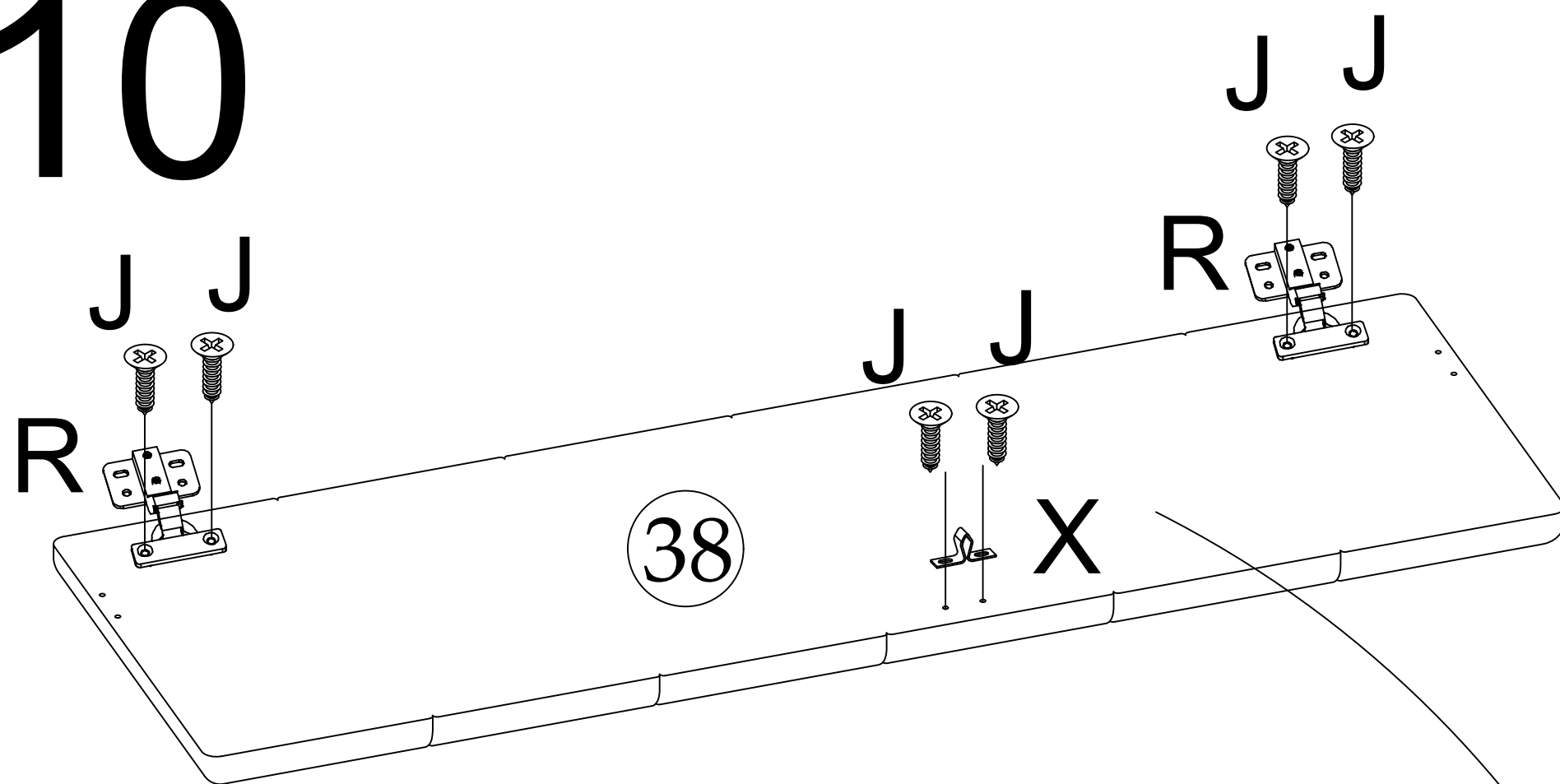

N	4x30	
F	4x25	

J	3x14		10PCS	R		2PCS
H			1PC	X		1PC

# ASSEMBLY INSTRUCTIONS

# 11

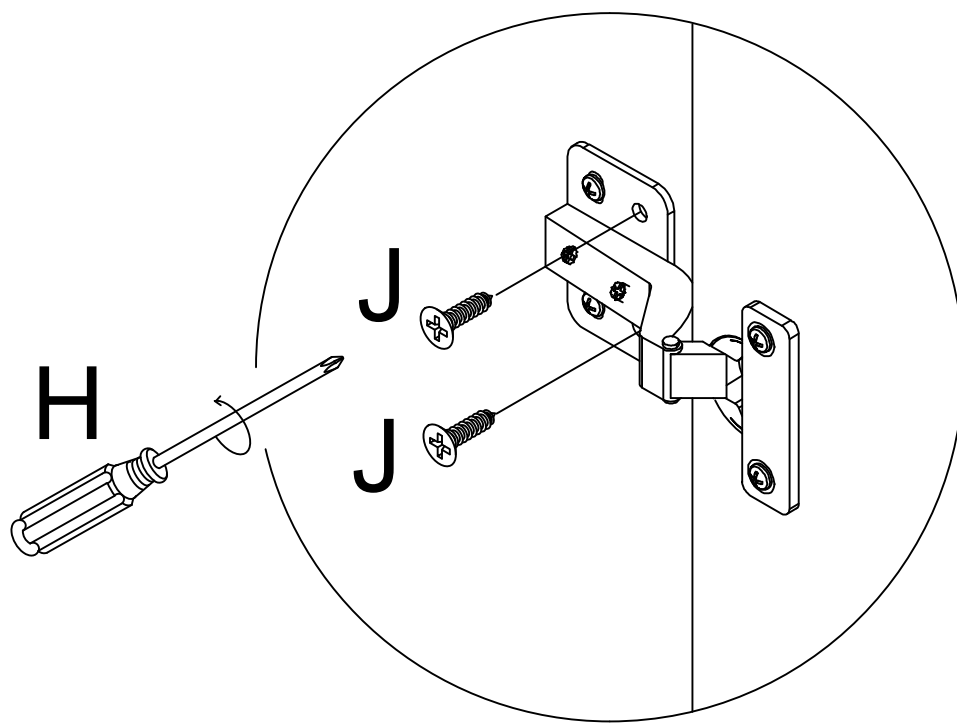
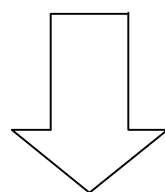
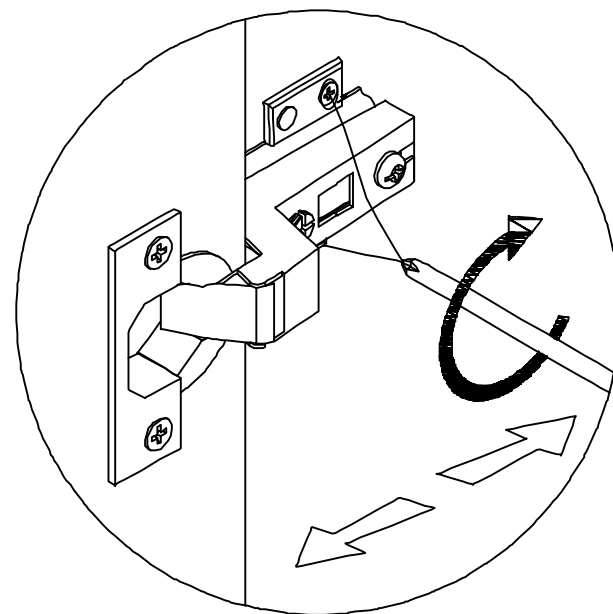
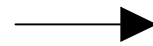
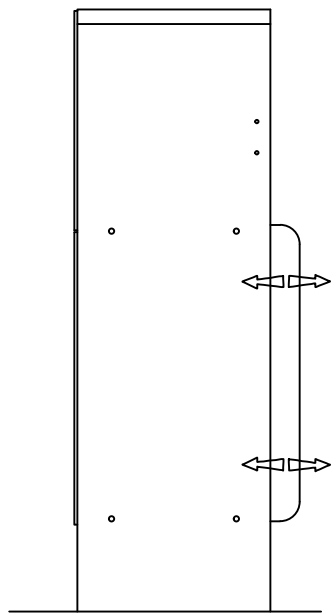
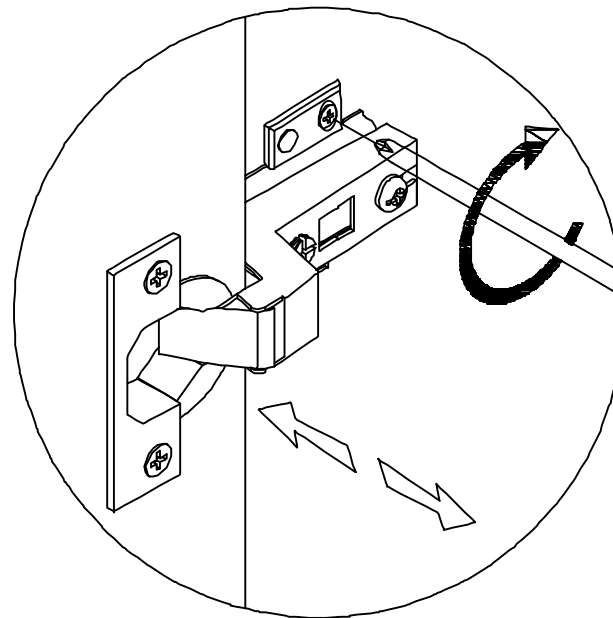
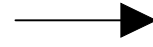
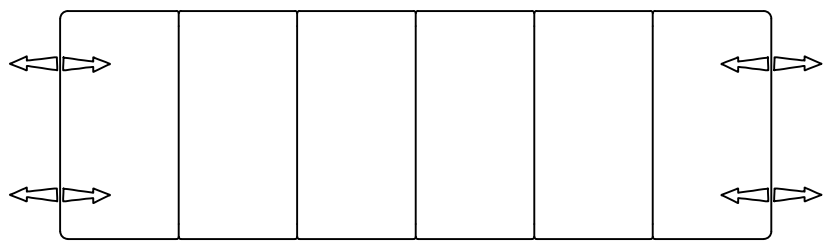
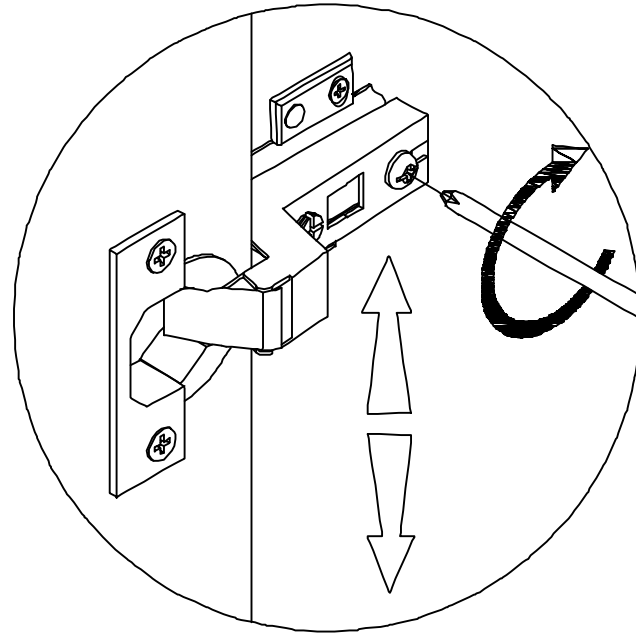
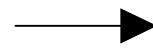
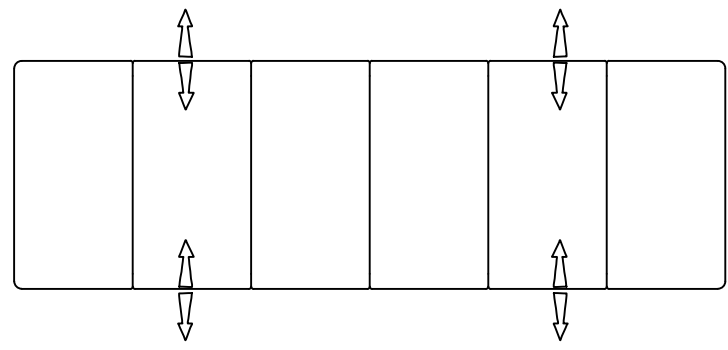



N	4x30	
F	4x25	

J	3x14		4PCS
H			1PC

# ASSEMBLY INSTRUCTIONS

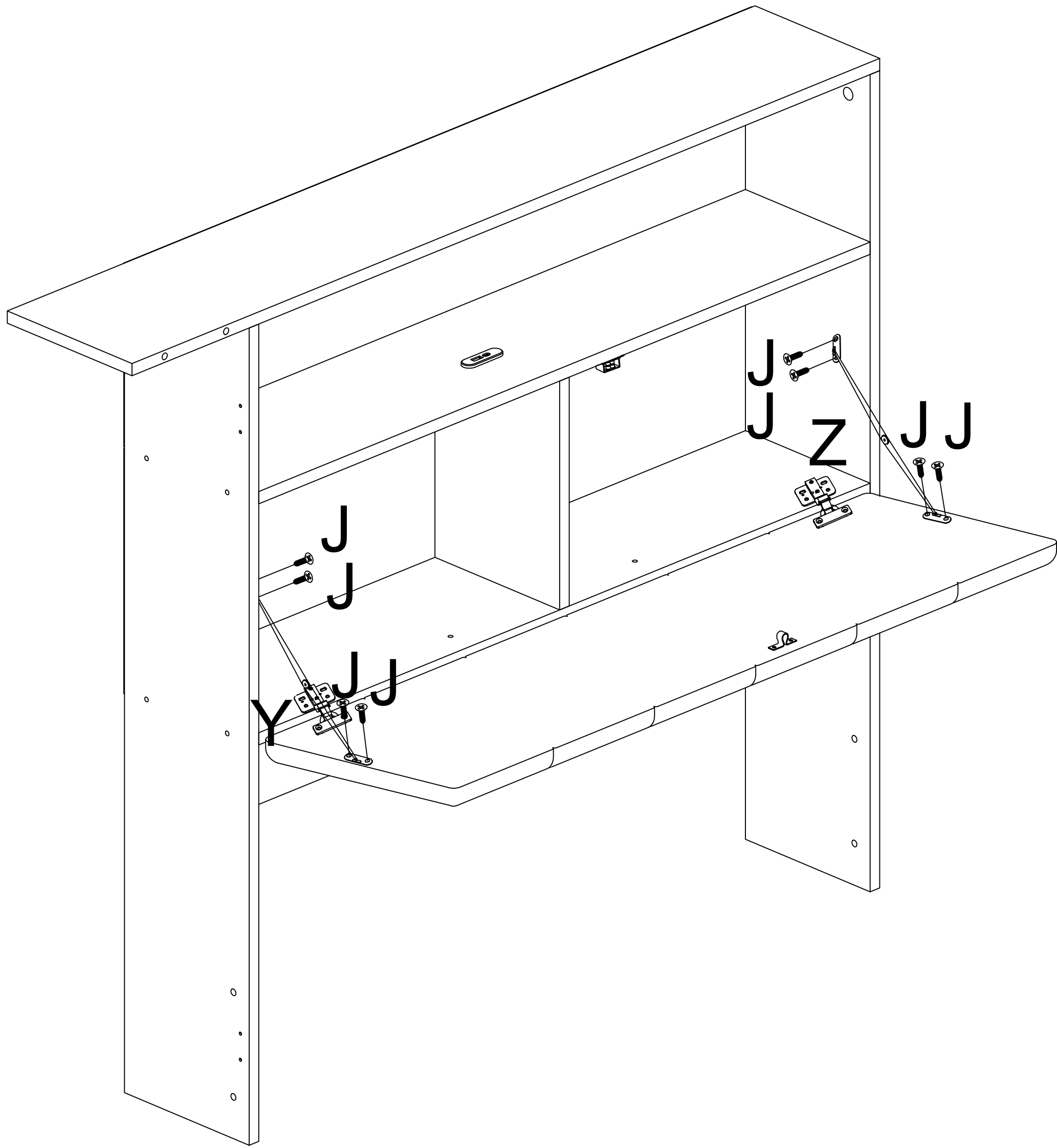
# 12



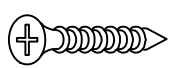

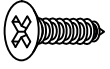
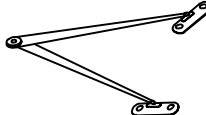
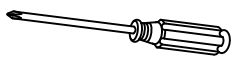
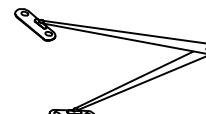
N	4x30	
F	4x25	

J	3x14		8PCS	Y		1PC
H			1PC	Z		1PC

# ASSEMBLY INSTRUCTIONS

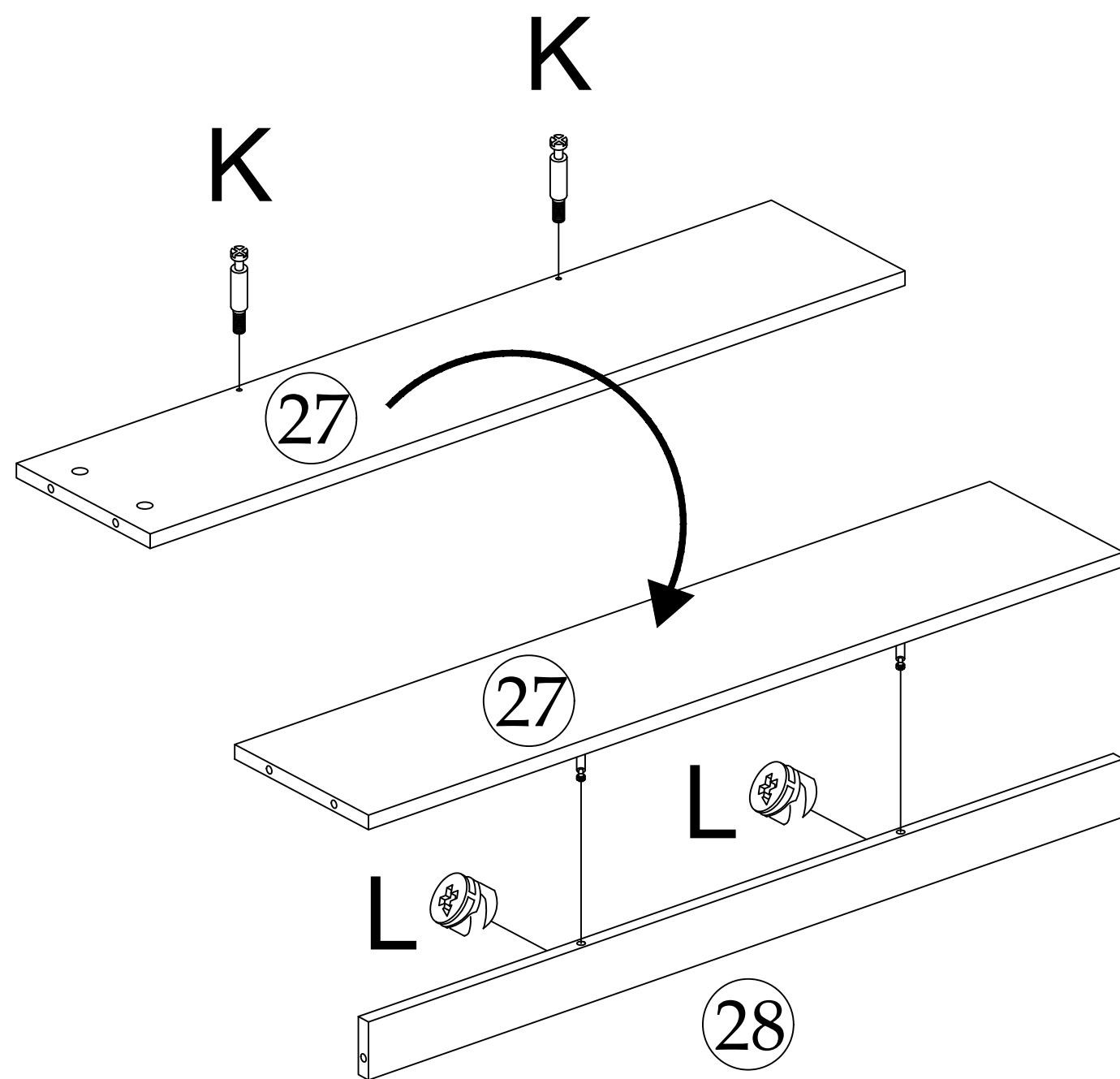
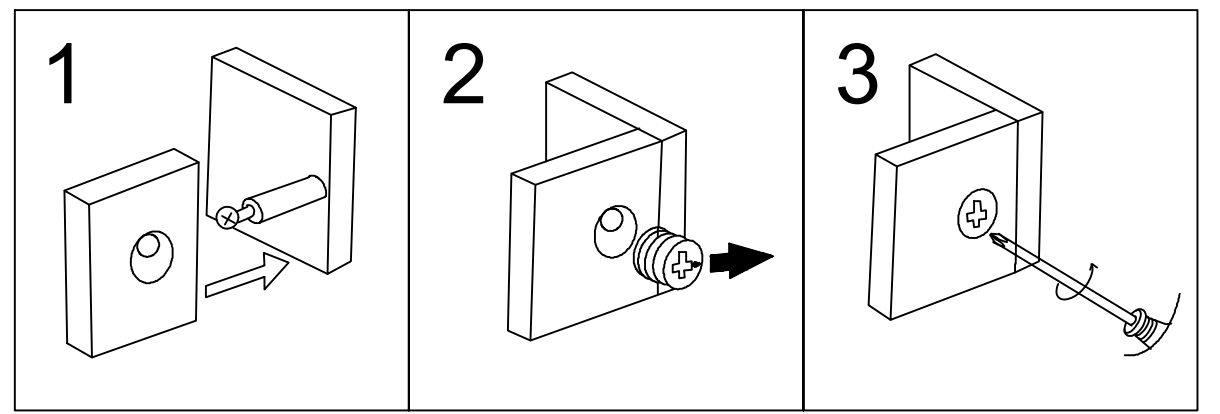
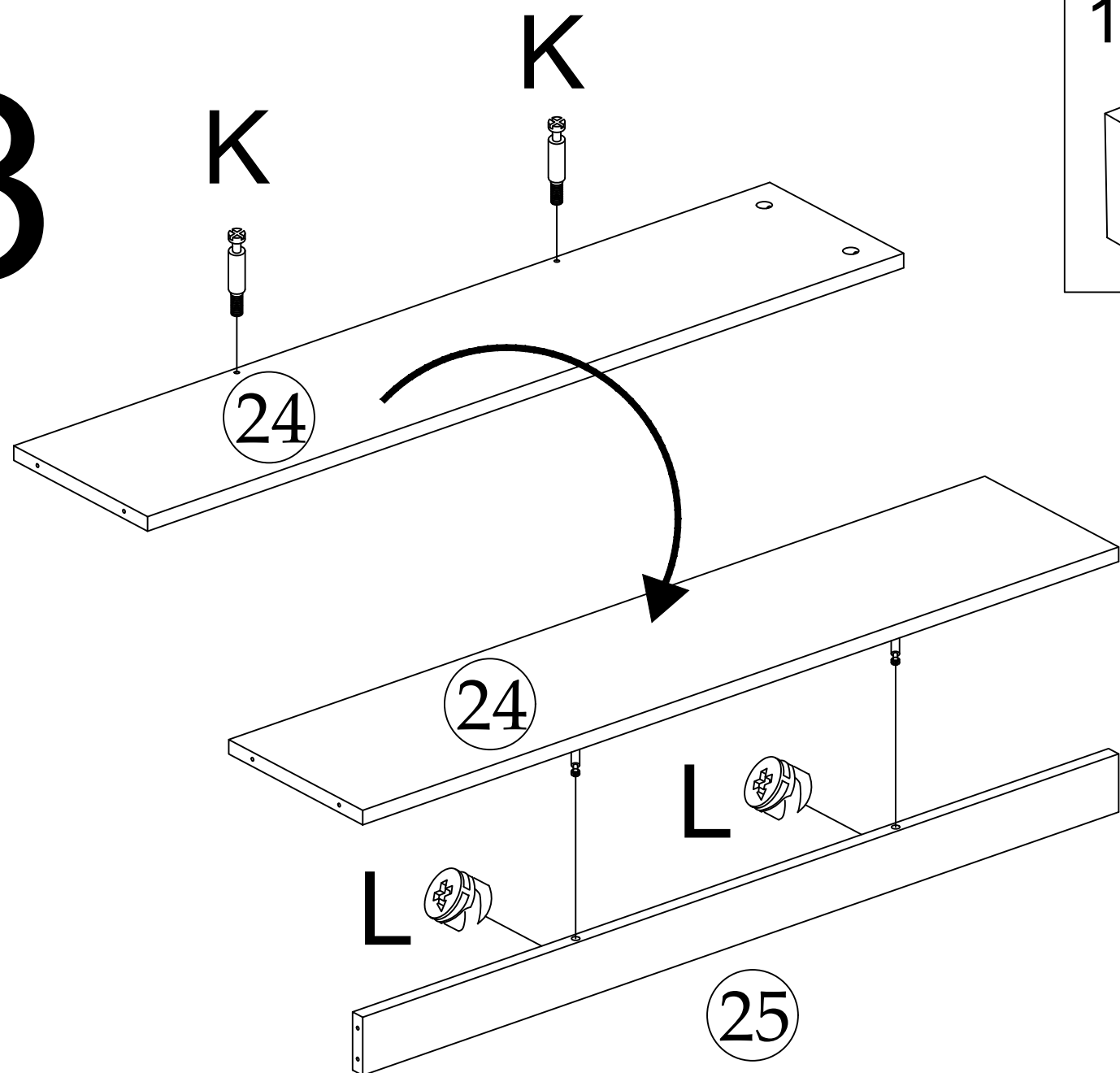
# 13

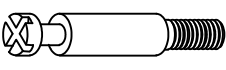

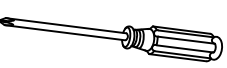

K		4PCS			
L		4PCS	H		1PC

# ASSEMBLY INSTRUCTIONS

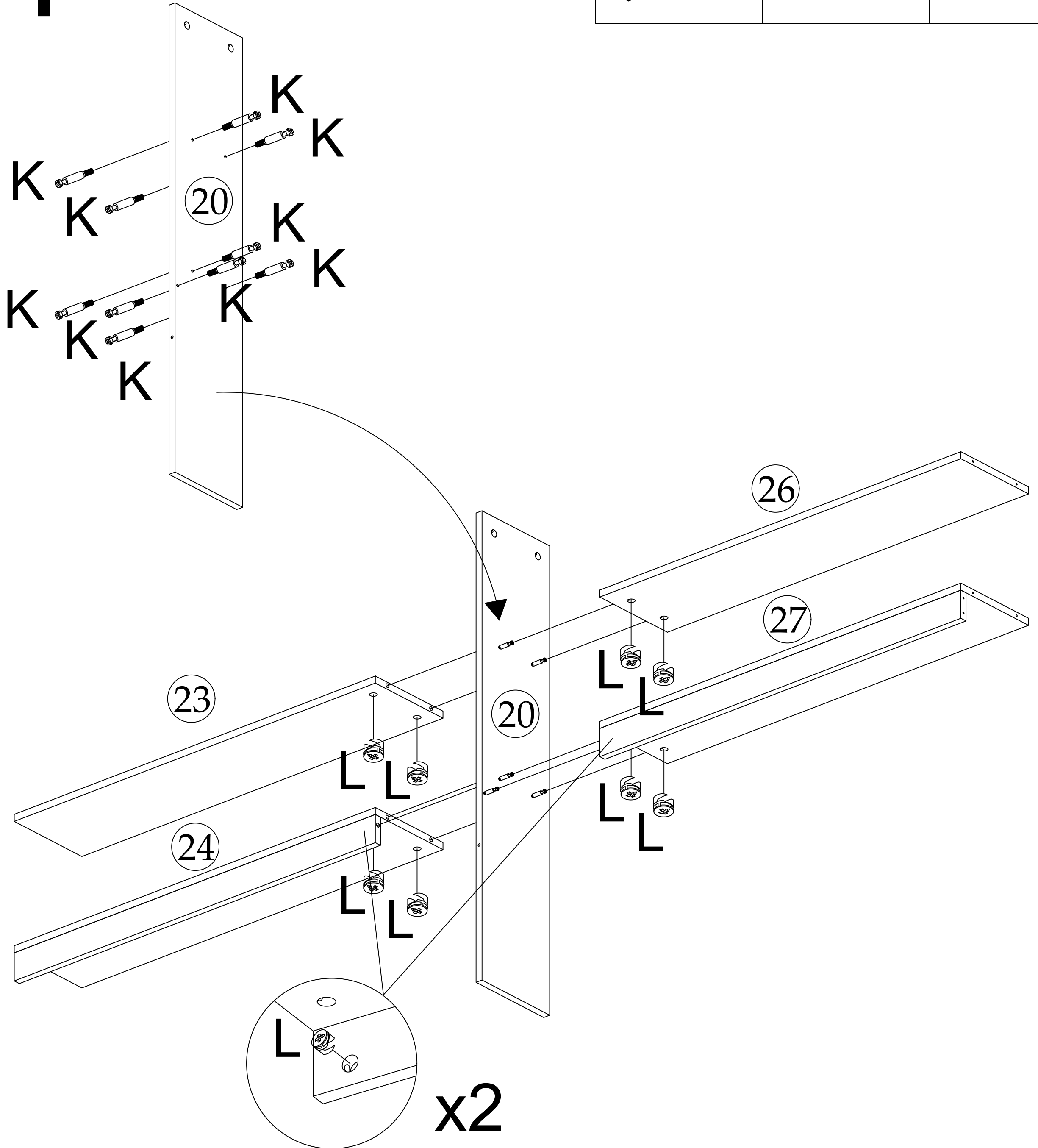
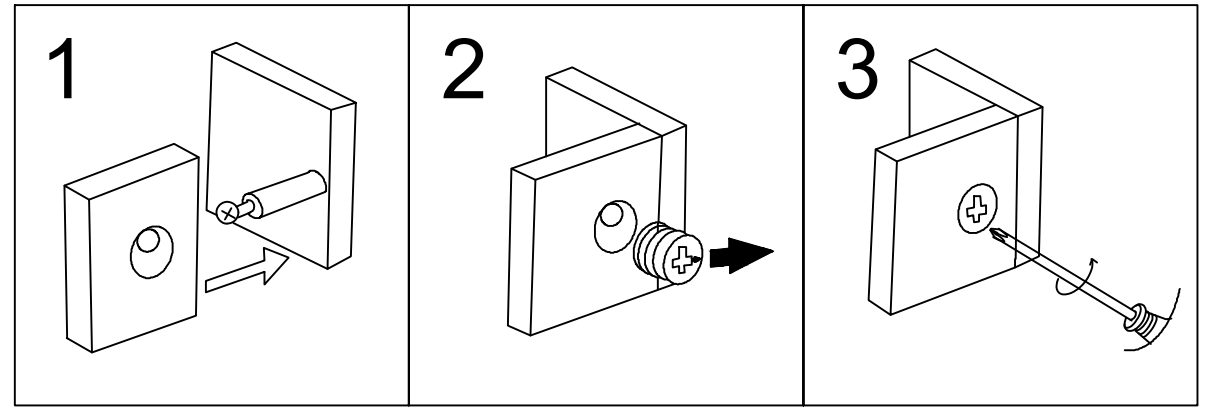
# 14

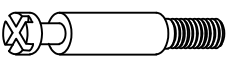

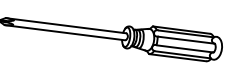
K		10PCS			
L		10PCS	H		1PC

# ASSEMBLY INSTRUCTIONS

# 15

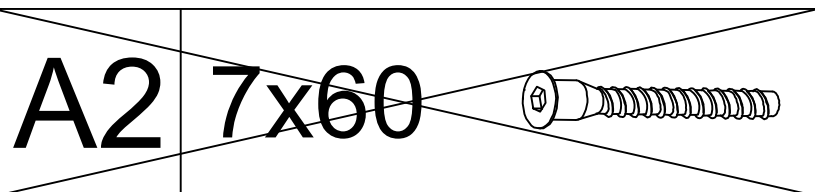
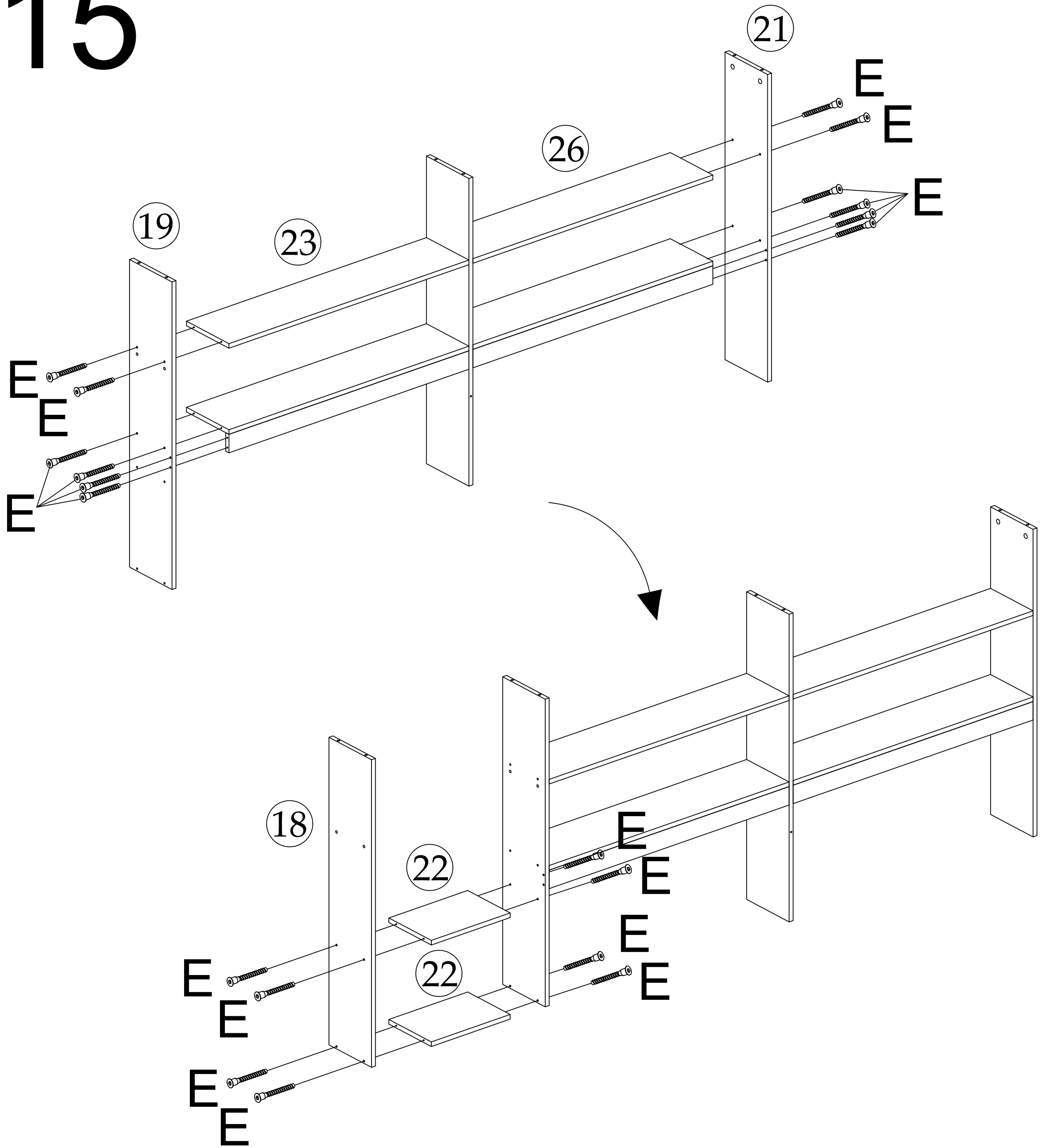

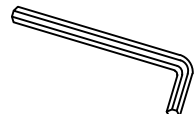

E	5x40		20PCS
G	M3		1PC

# ASSEMBLY INSTRUCTIONS

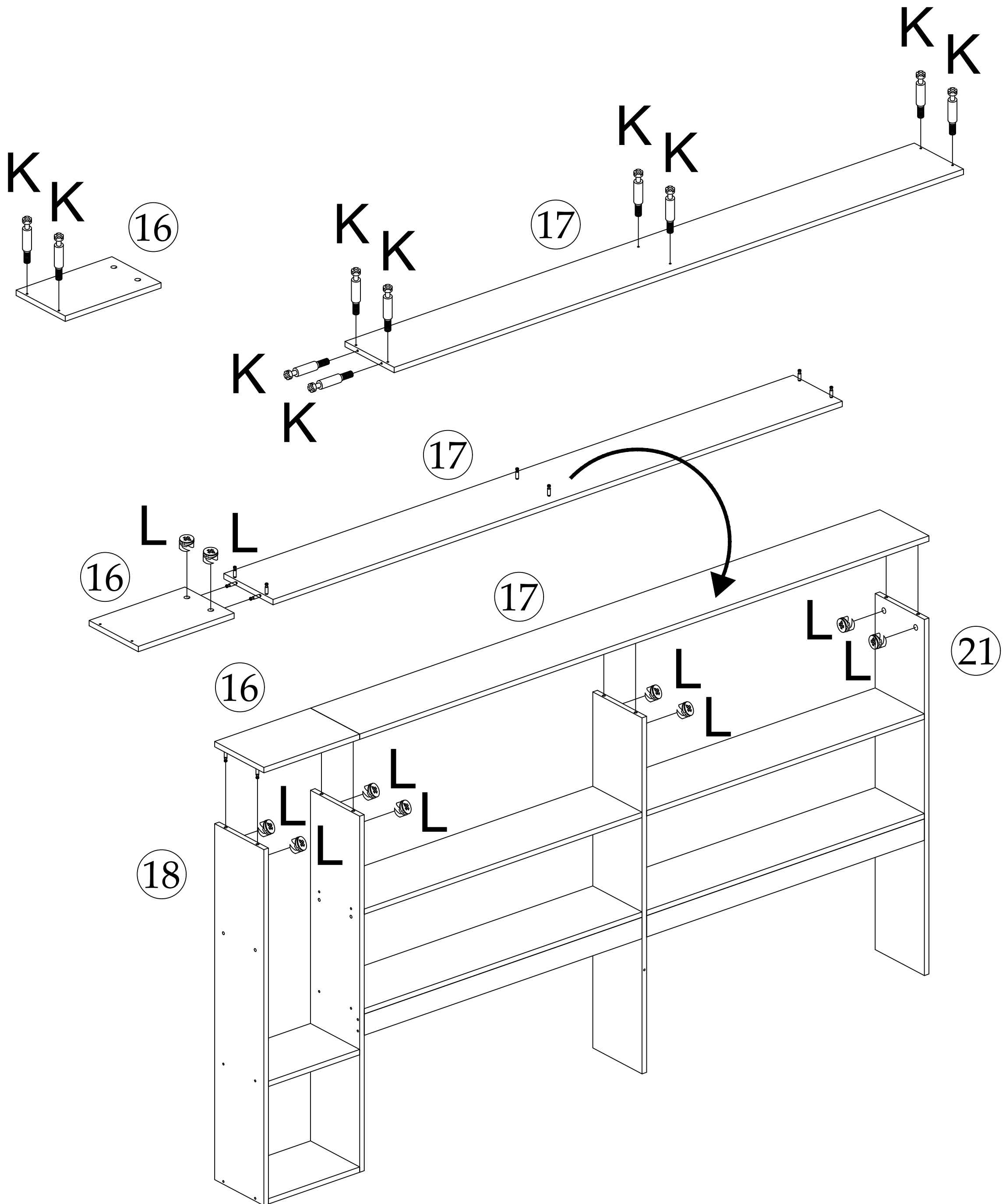
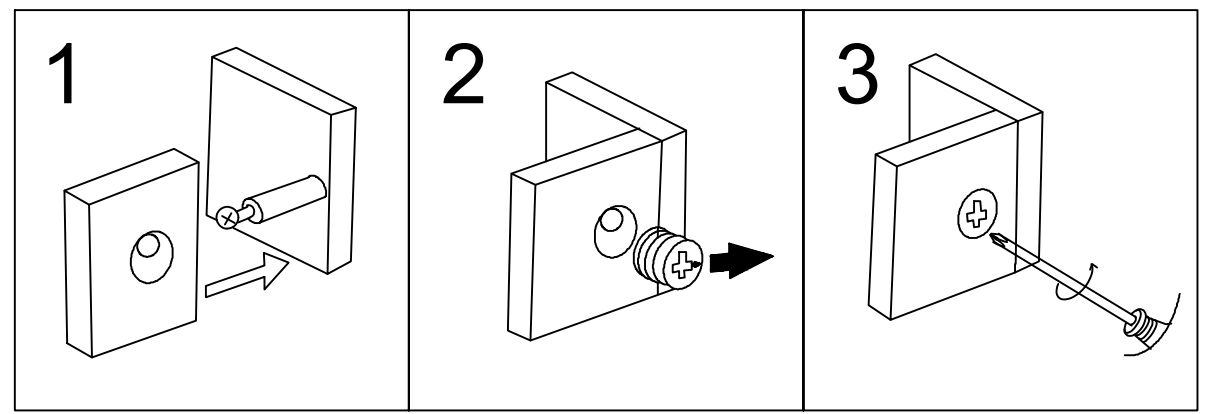
# 16

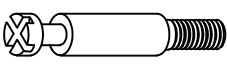

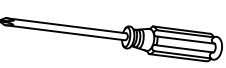
K		10PCS			
L		10PCS	H		1PC

# ASSEMBLY INSTRUCTIONS

# 17

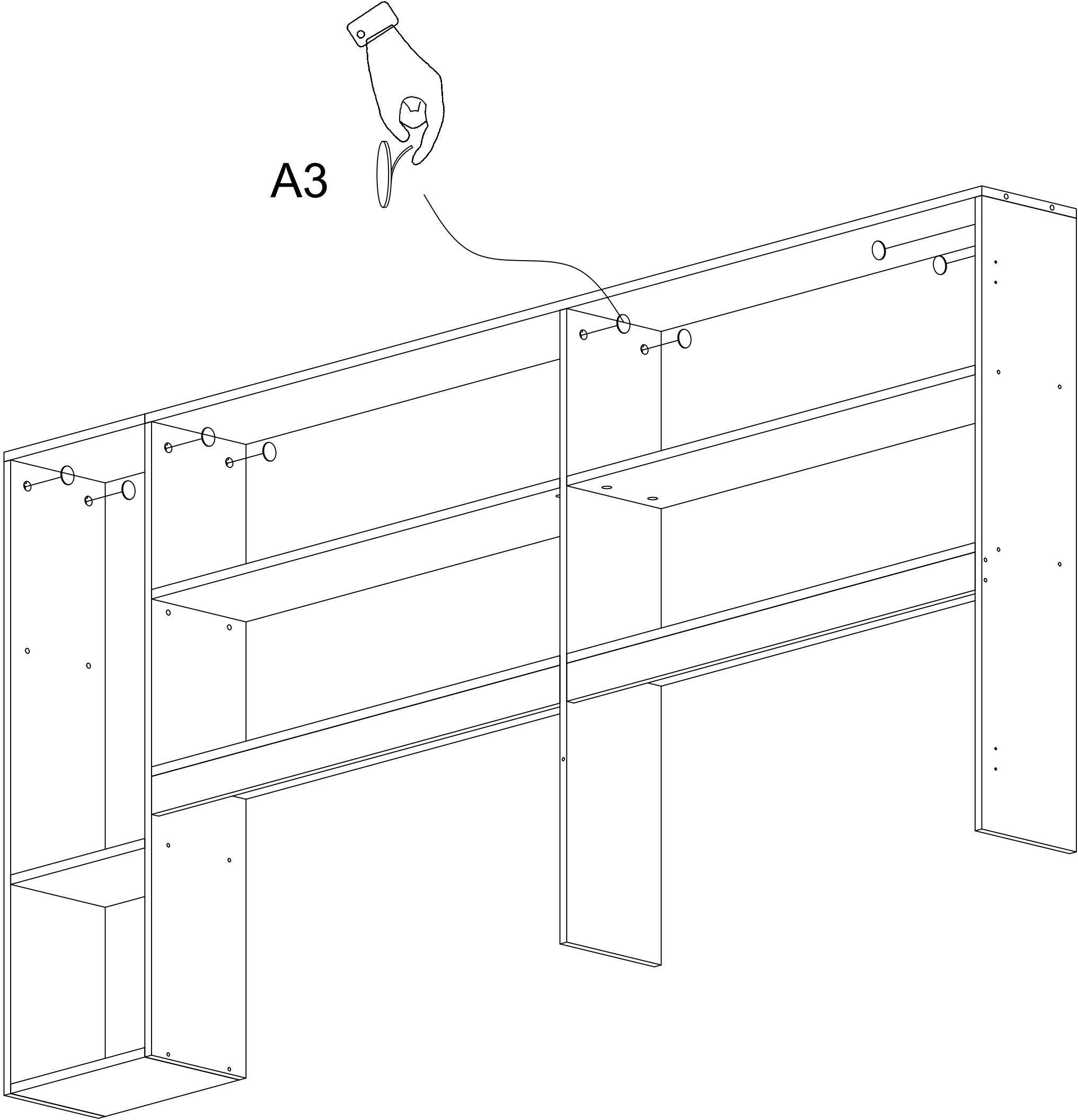

A3

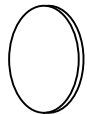

8PCS

# ASSEMBLY INSTRUCTIONS

# 18

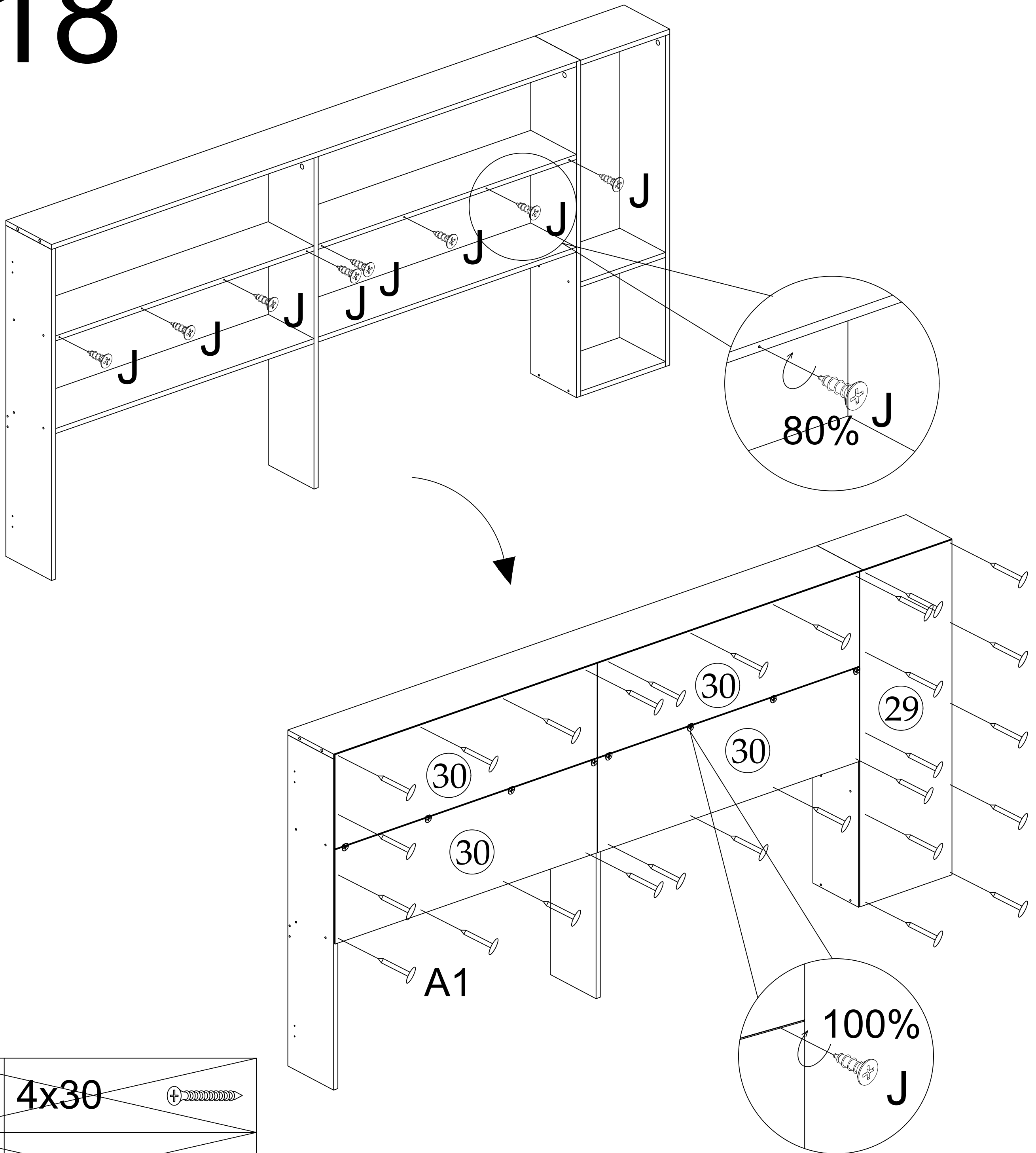



N	4x30	
F	4x25	

J	3x14		8PCS			
H			1PC	A1		28PCS

# ASSEMBLY INSTRUCTIONS

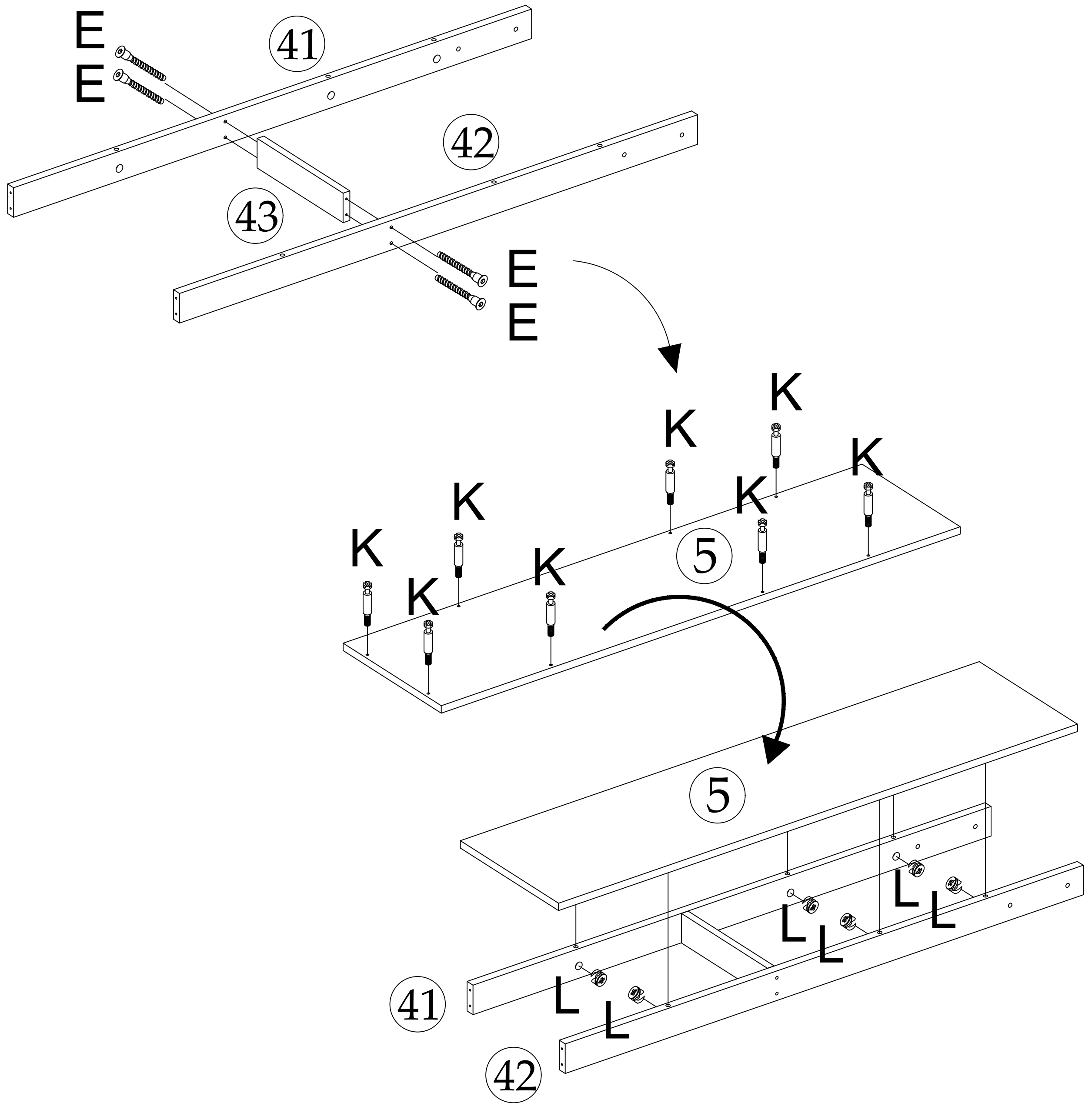
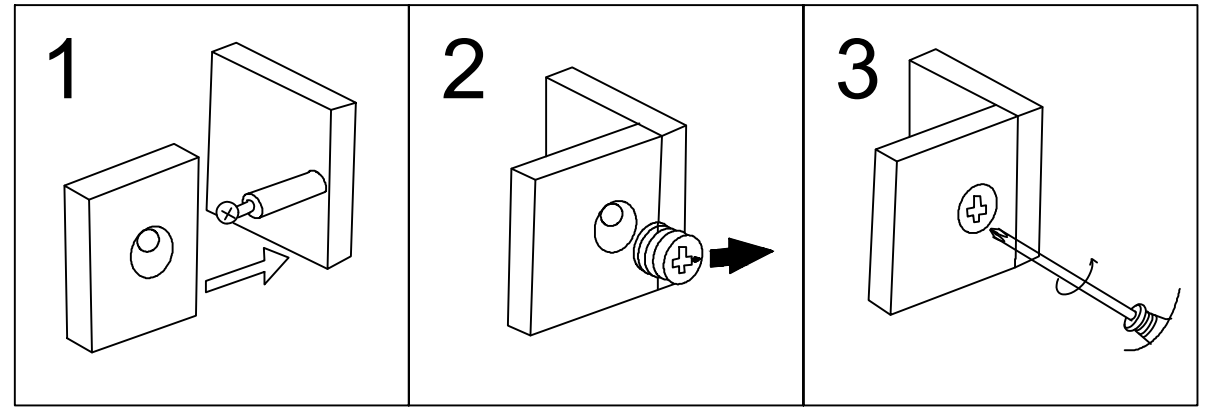
# 19

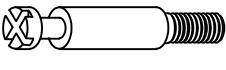
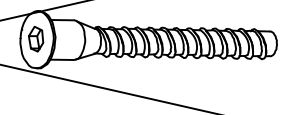

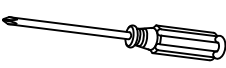
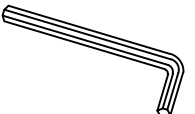

K		8PCS	A2 7x60 		
L		6PCS	E	5x40	 4PCS
H		1PC	G	M3	 1PC

# ASSEMBLY INSTRUCTIONS

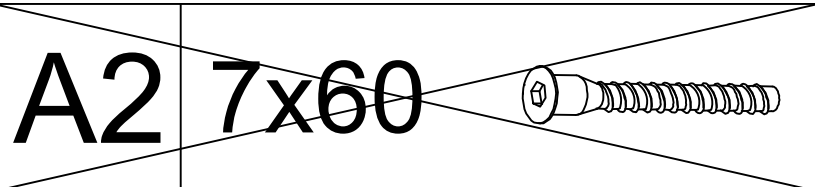
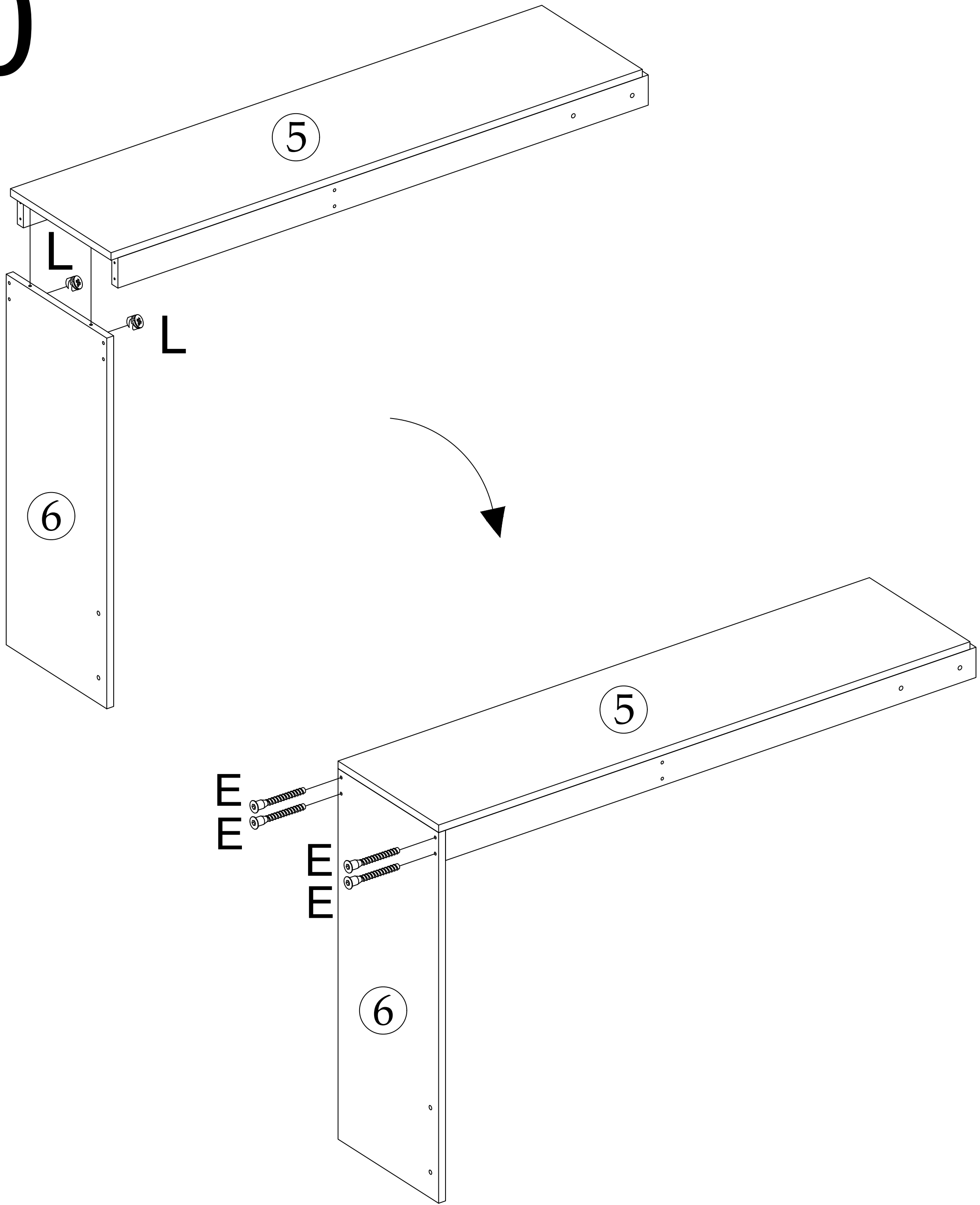
# 20

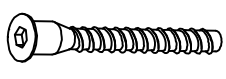

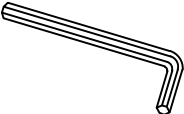
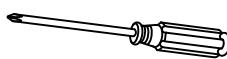
E	5x40		4PCS	L		2PCS
G	M3		1PC	H		1PC

# ASSEMBLY INSTRUCTIONS

# 21

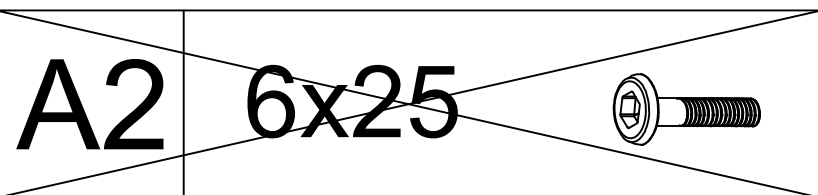
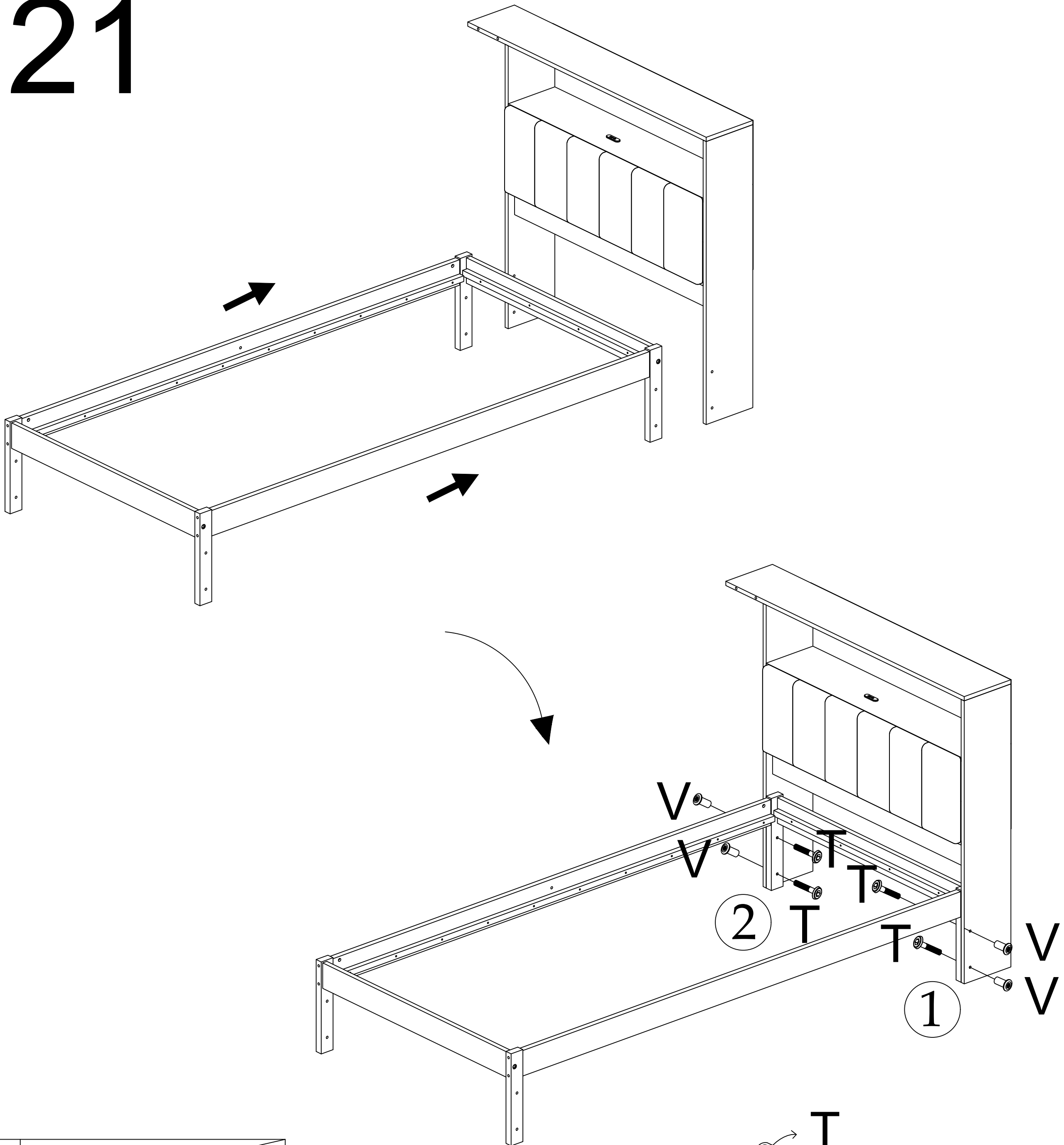

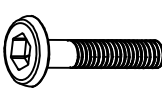
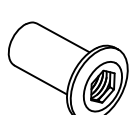
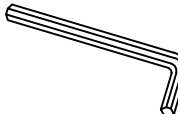
T	6x30		4PCS
V	8x20		4PCS
M			2PCS

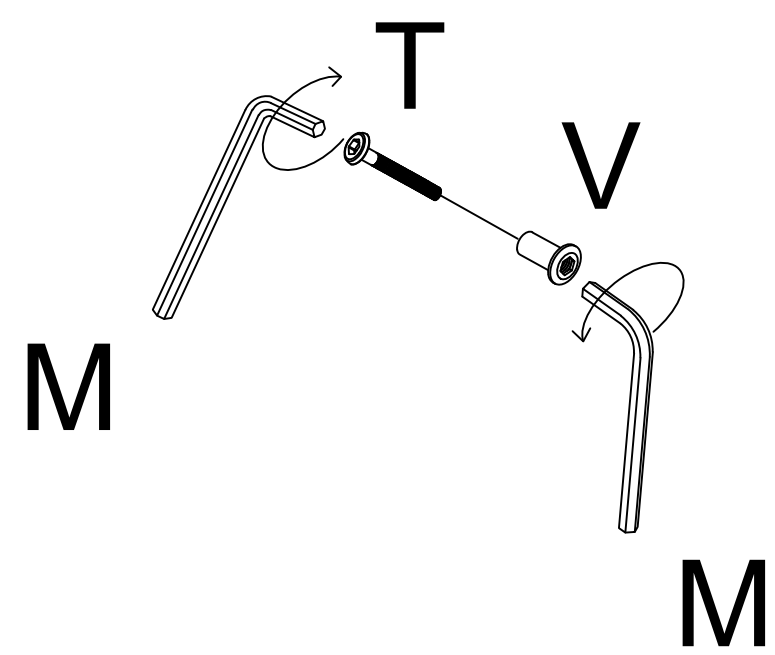

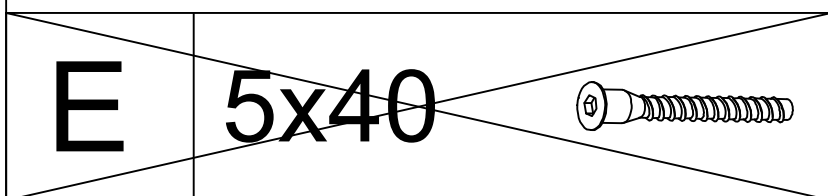
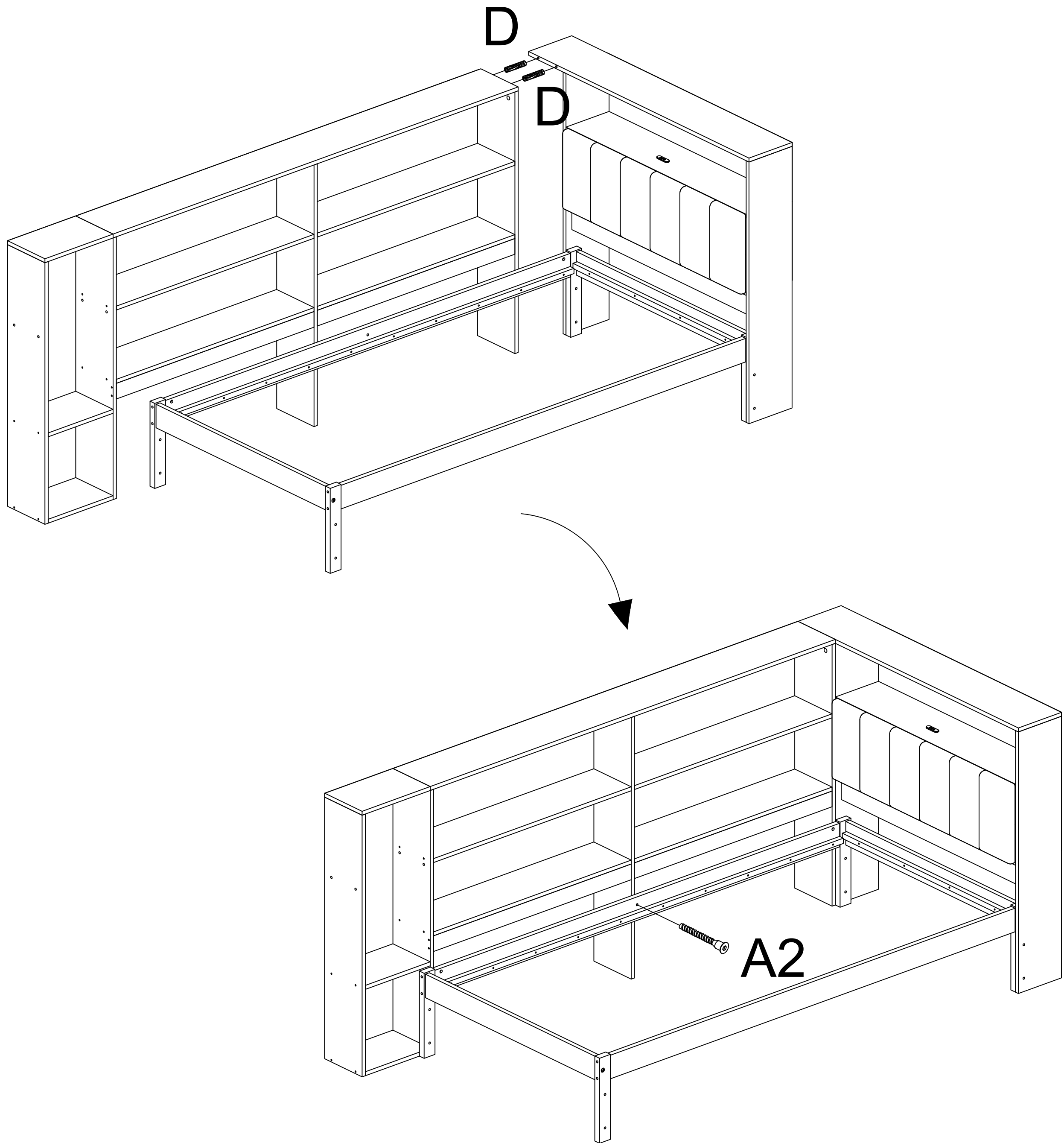

# ASSEMBLY INSTRUCTIONS

# 22

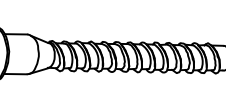

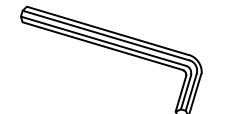
A2	7x60		1PC
----	------	---	-----

M	M4		1PC	D	8x30	 2PCS
---	----	---	-----	---	------	--

# ASSEMBLY INSTRUCTIONS

# 23

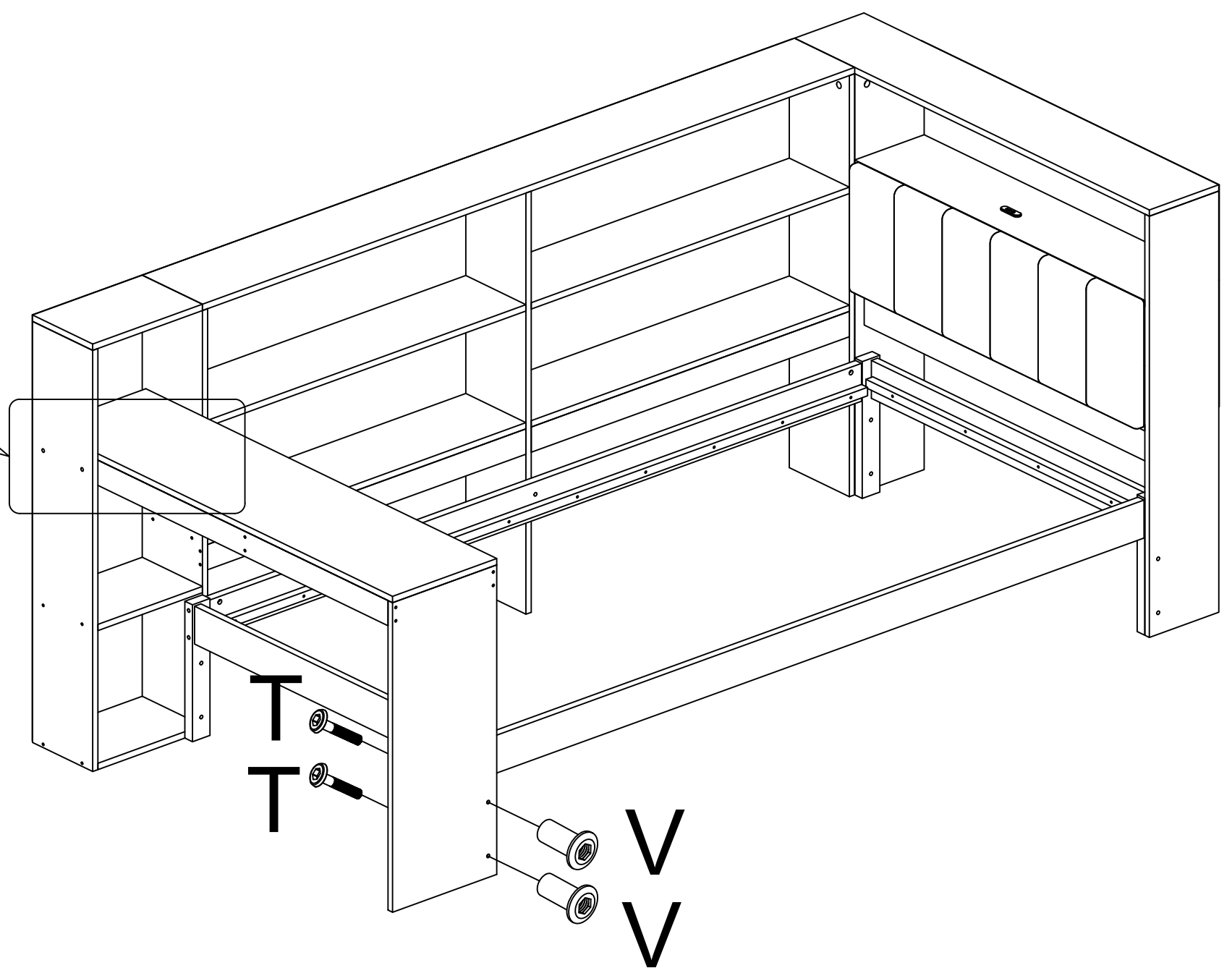
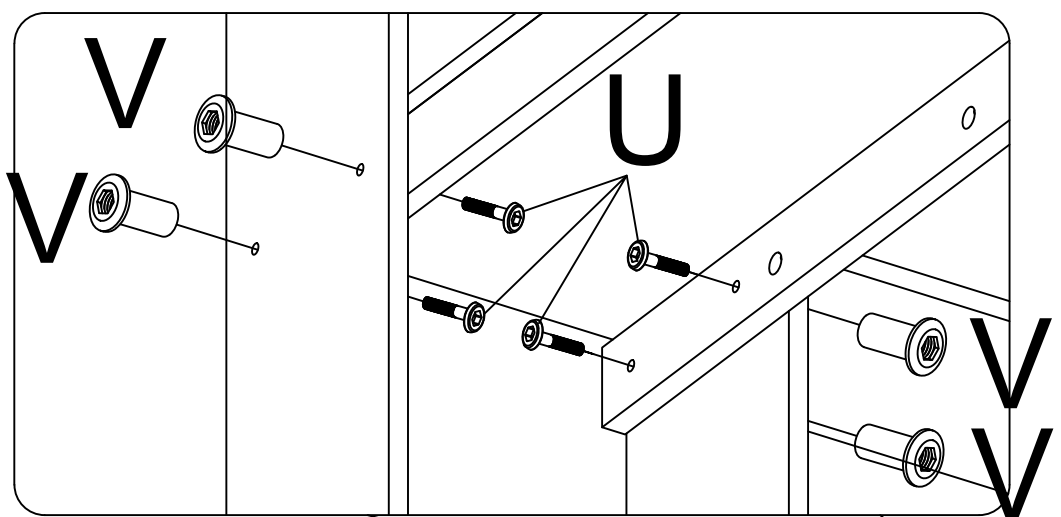
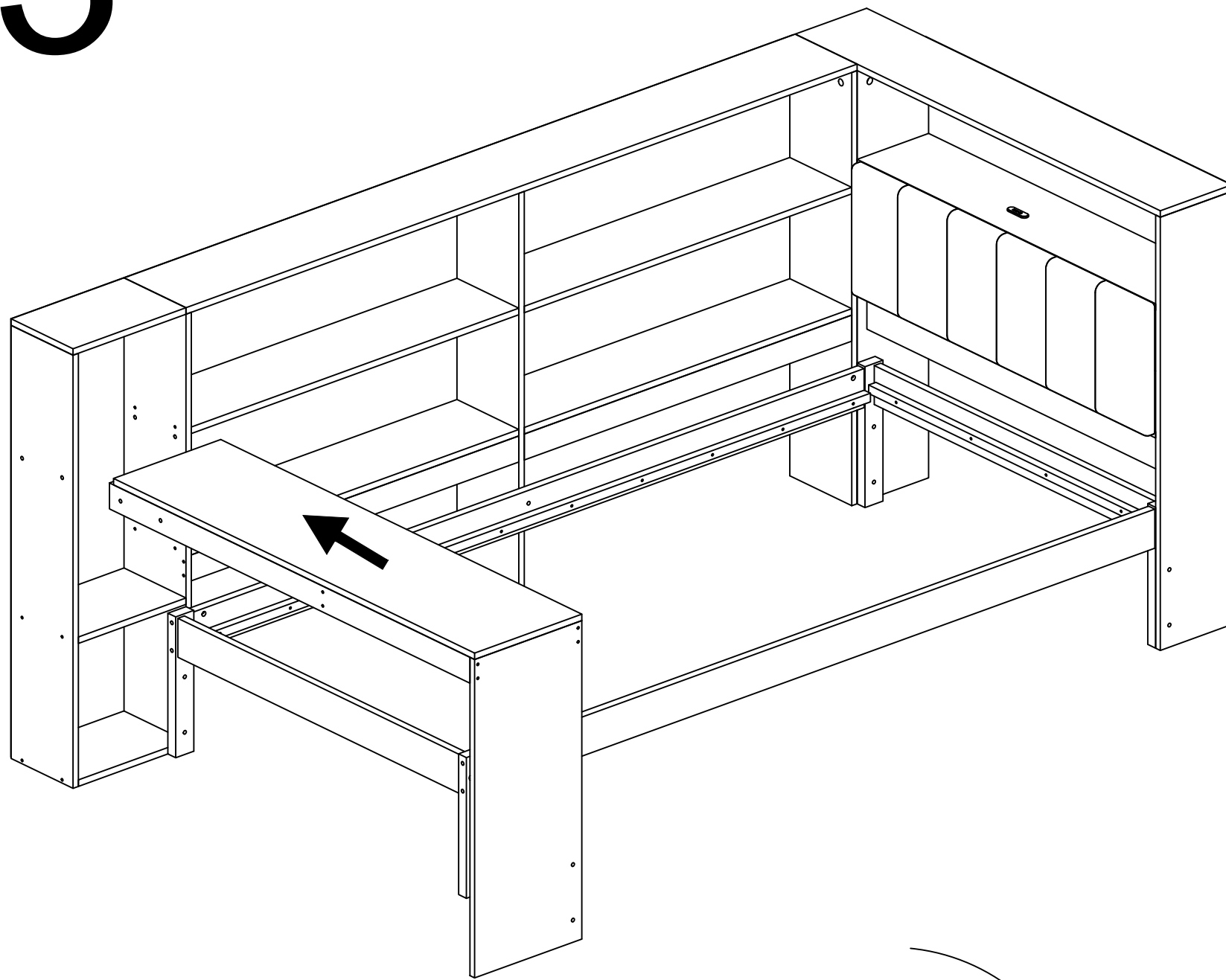

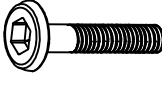
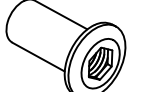
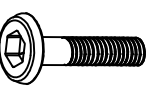
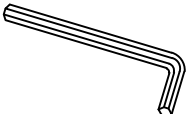
T	6x30		2PCS	V	8x20		6PCS
U	6x25		4PCS	M			2PCS

# ASSEMBLY INSTRUCTIONS

# 24

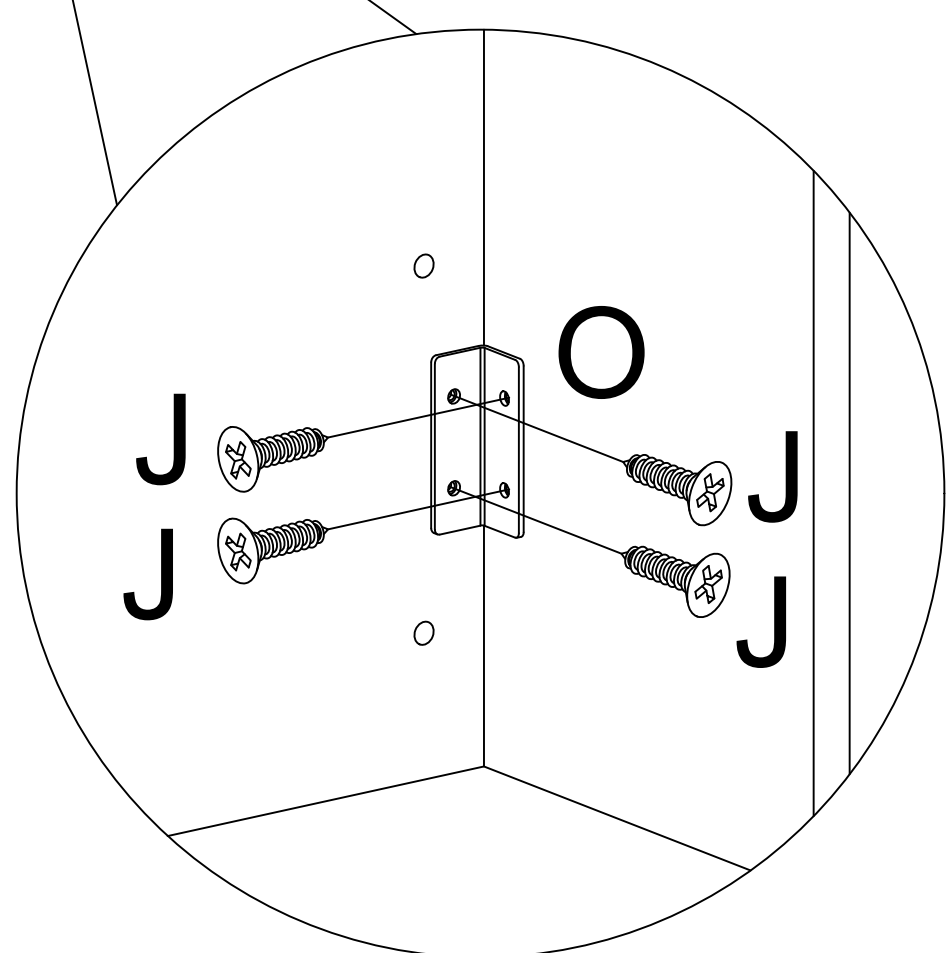
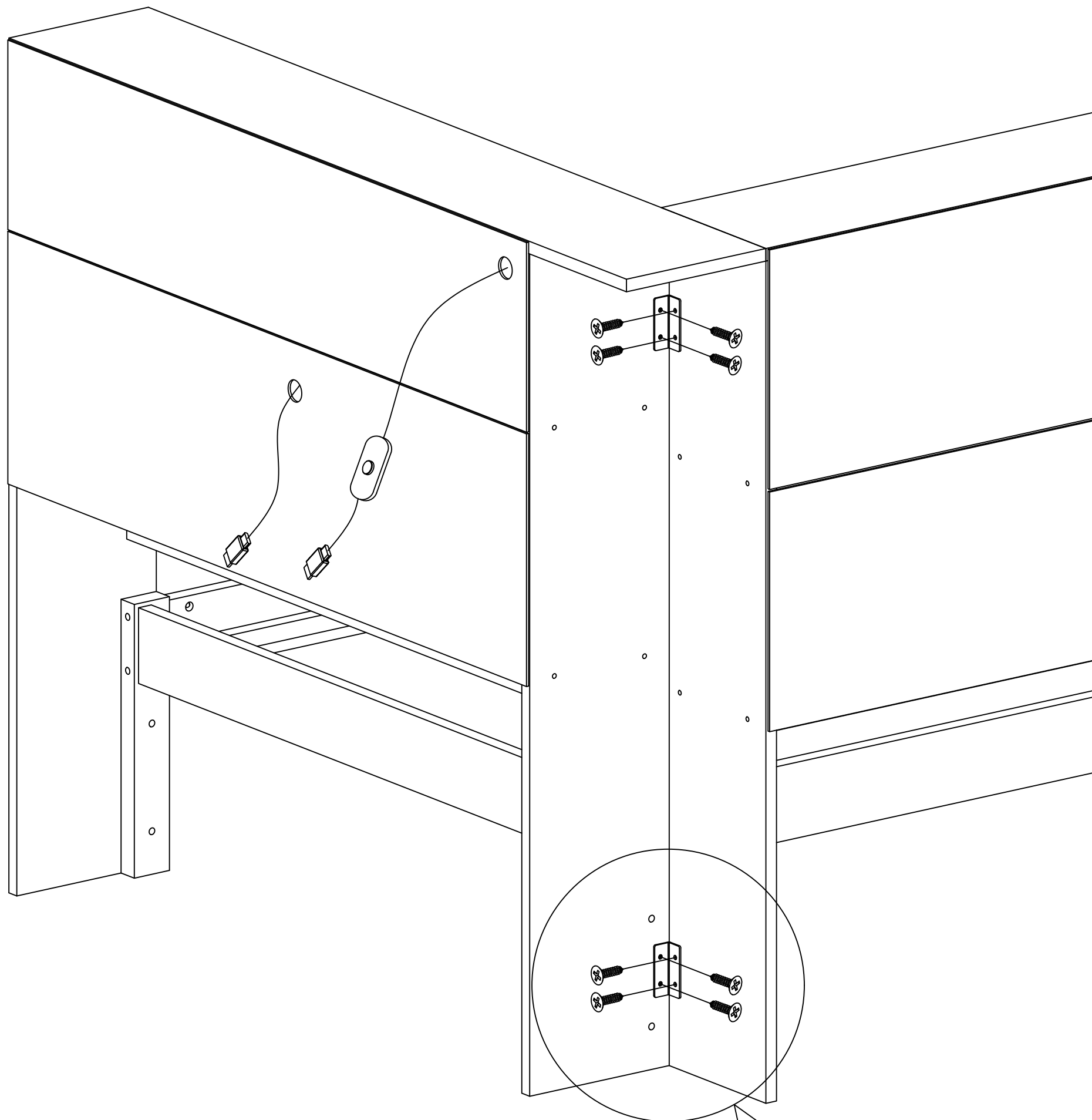

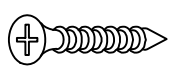
N	4x30	
F	4x25	

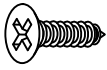
J	3x14		8PCS
---	------	---	------

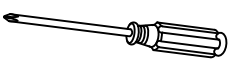
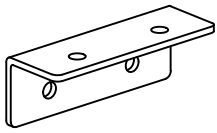
H			1PC	O		2PCS
---	--	---	-----	---	---	------

# ASSEMBLY INSTRUCTIONS

# 25

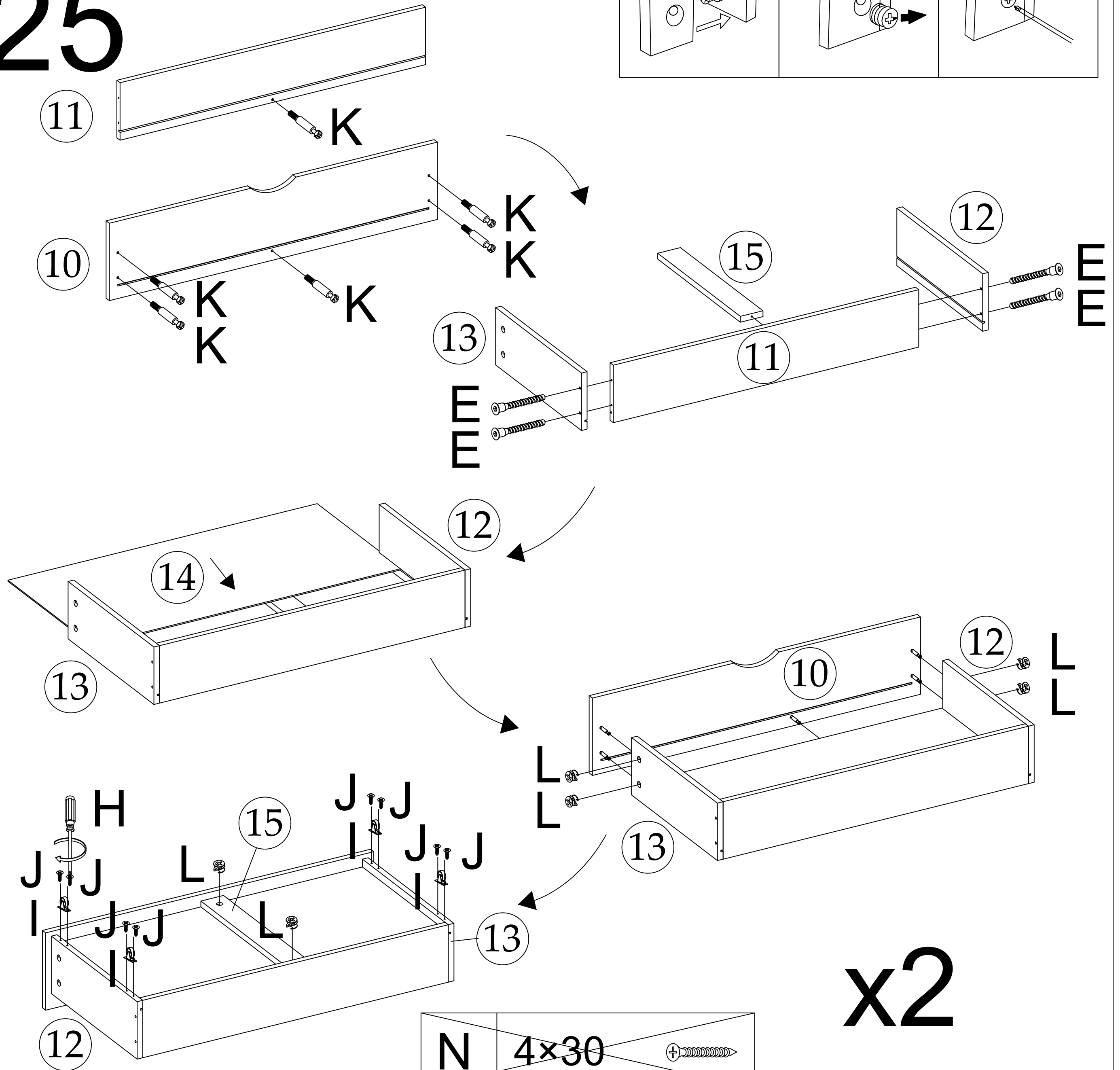
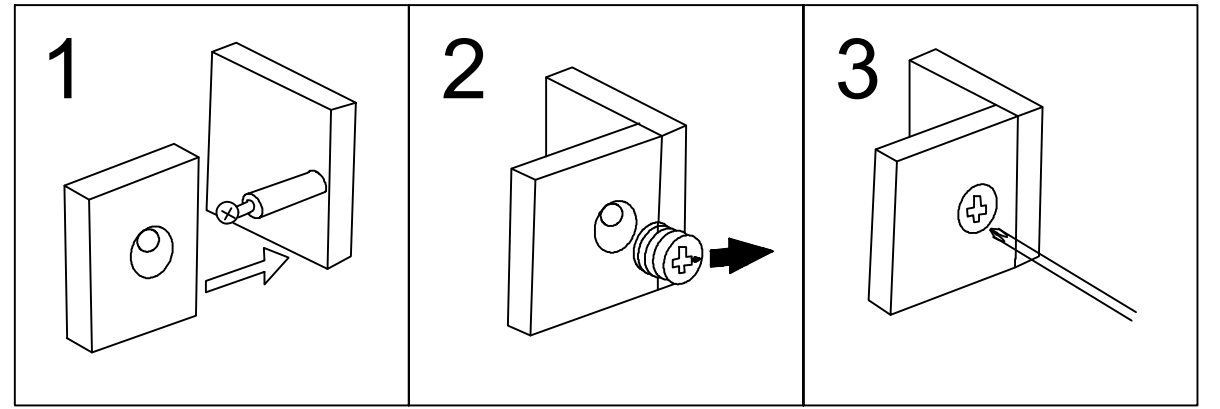

N	4x30	
F	4x25	

E	5x40		8PCS			
G	M3		1PC	J	3x14	16PCS
I			8PCS	K		12PCS
H			1PC	L		12PCS

# ASSEMBLY INSTRUCTIONS

# 26

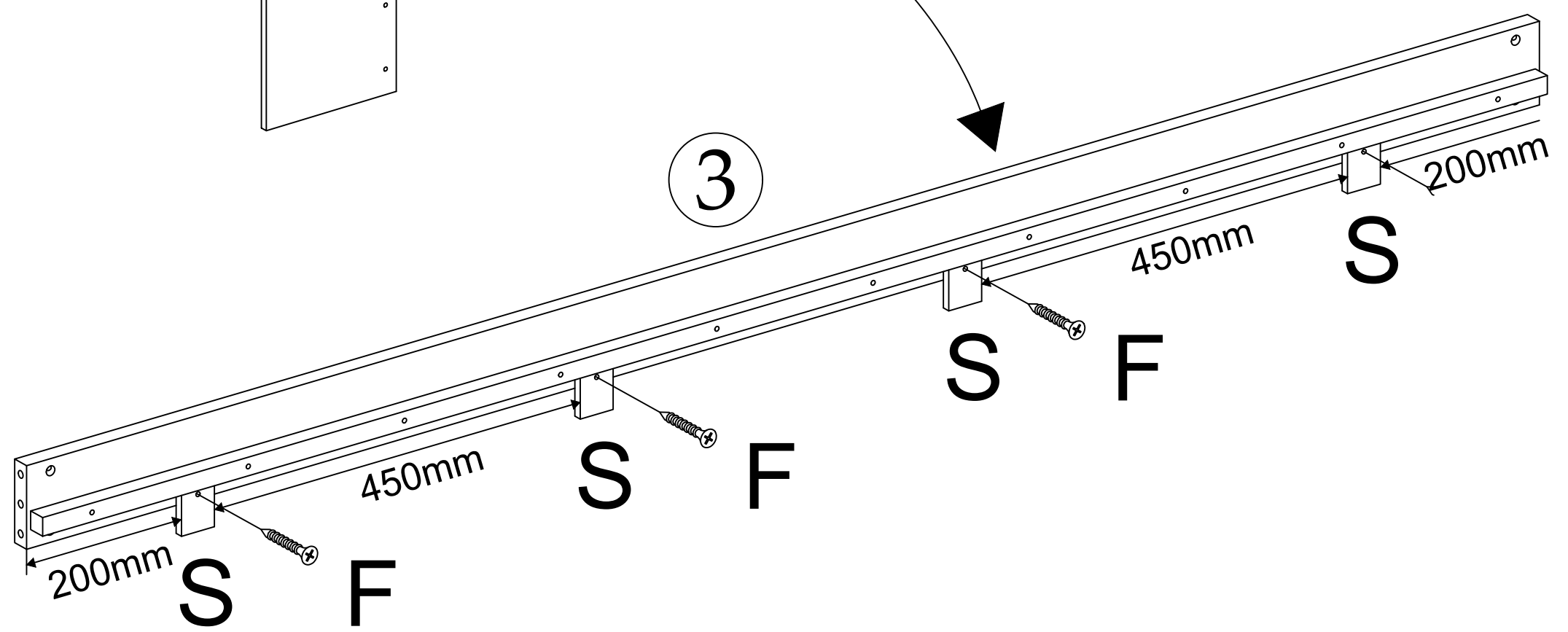
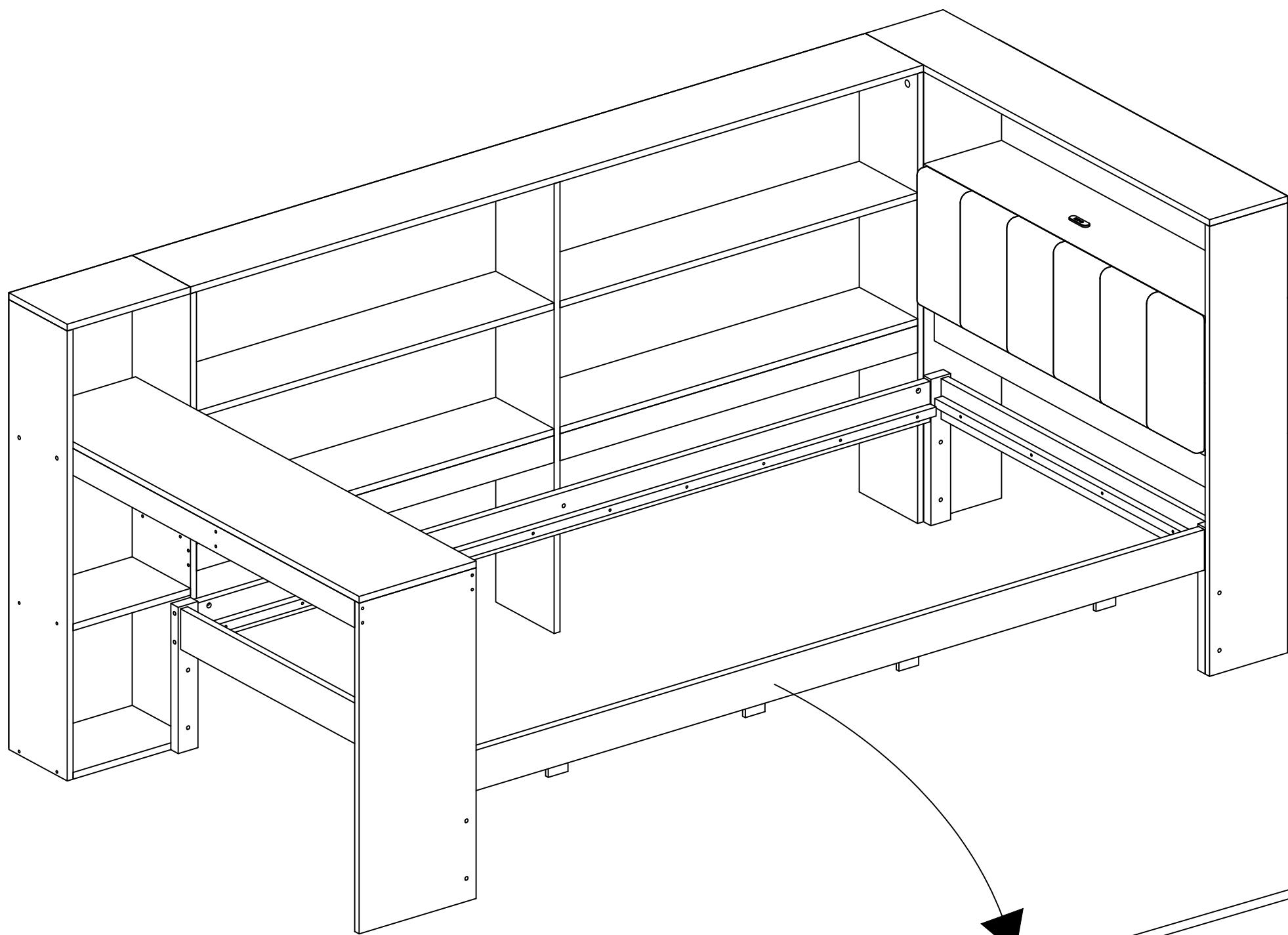

N	4x30	
J	3x14	

S		4PCS
F		1PC

# ASSEMBLY INSTRUCTIONS

# 27

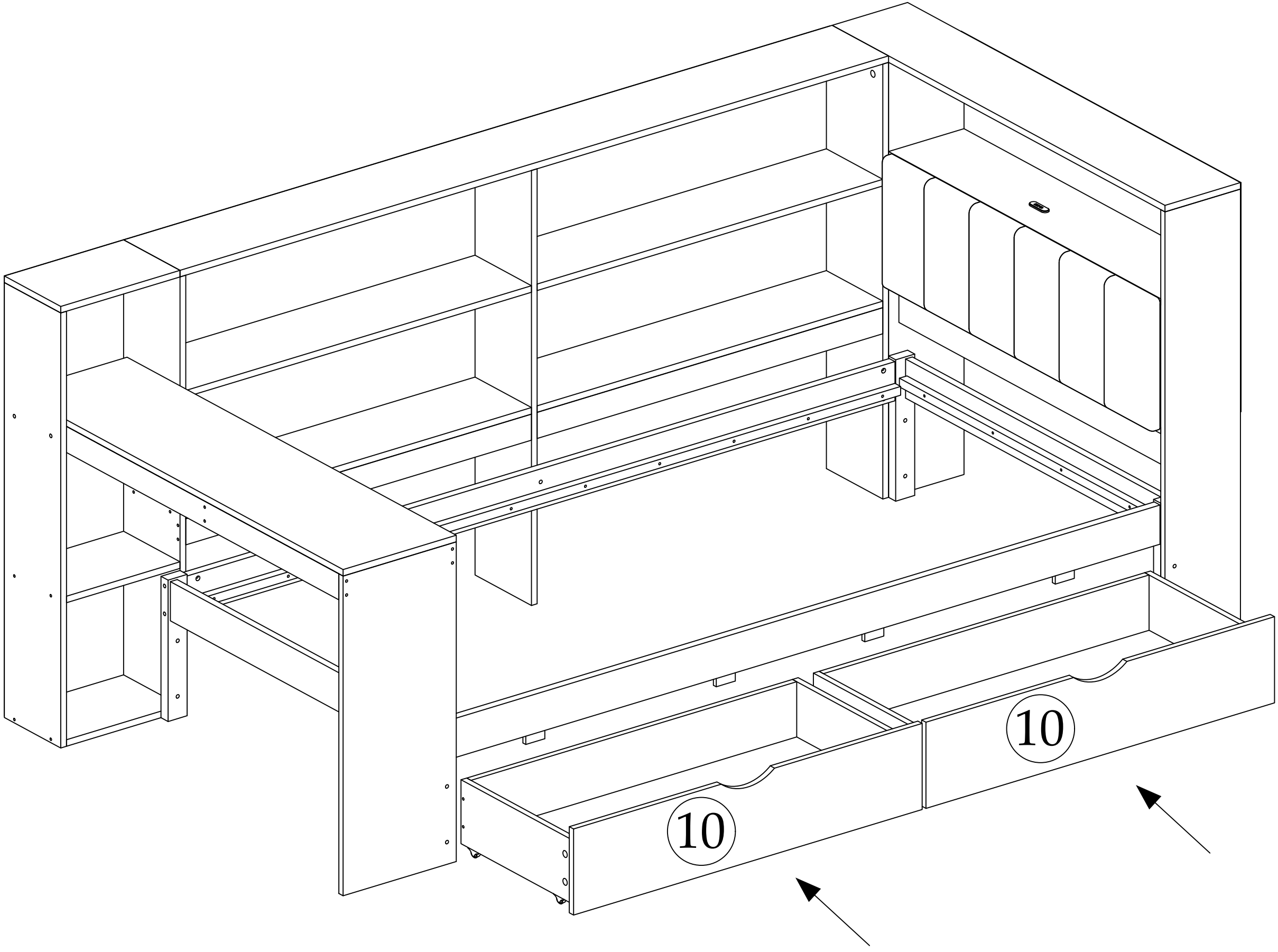

# ASSEMBLY INSTRUCTIONS

# 28

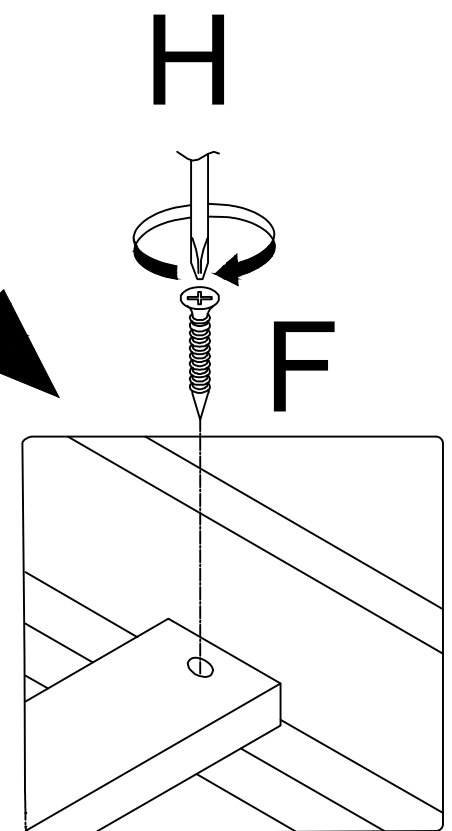
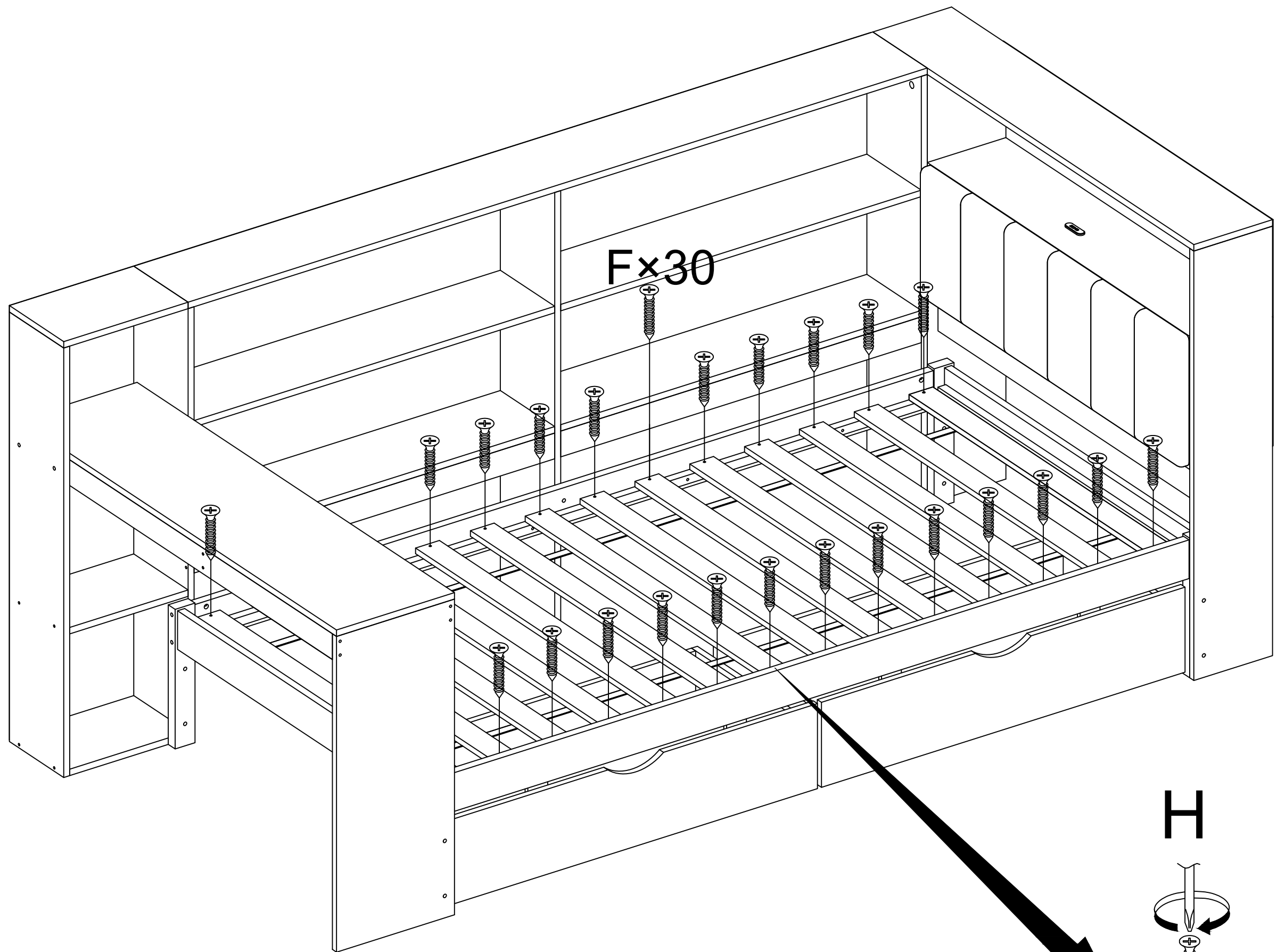

N	4x30	
J	3x14	

F	4x25		30PCS
H			1PC

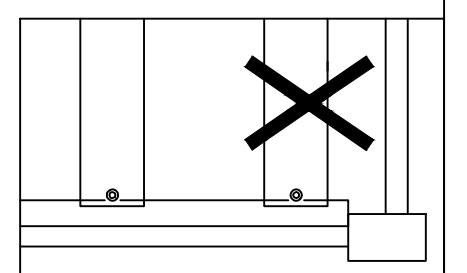
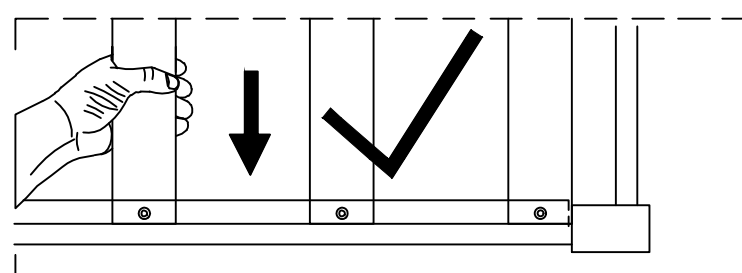

# Led Bluetooth Mini Controller Manual



1

## Download App Software

Please download "LotusLamp X" in the app store or scan the QR code below to download.



1. Download the "LotusLamp X" app with your phone by scanning the QR code on the user manual or searching for the Lotus Lamp app in the iPhone App Store or Google Play Store
2. After the APP are downloaded successfully, you need to turn on Bluetooth function on your phone firstly, then plug in the strip light, then open the APP, your APP will pair with the strip light automatically and you can control it.

## Unable to Connect Troubleshooting

- (1) Check if the power supply of the light strip is normal.
- (2) Check if the Bluetooth is turn on.
- (3) Check if there are other mobile phone are connected, Bluetooth 4.0 only support connections one to many, dose not support many to many.
- (4) Check APP Bluetooth setting if the phone is connected to the device, if connect, exit the APP and reopen, the APP will go to connect automatically.
- (5) Normal operations and can not connect, please exit the APP and reopen.
- (6) Exit APP, restart mobile phone, power on the strip light, reopen the APP, then them will connect automatically.

2

## Instructions

Scan the code or search to get the following APP, open the APP 



1. Open the control software to get the following interface

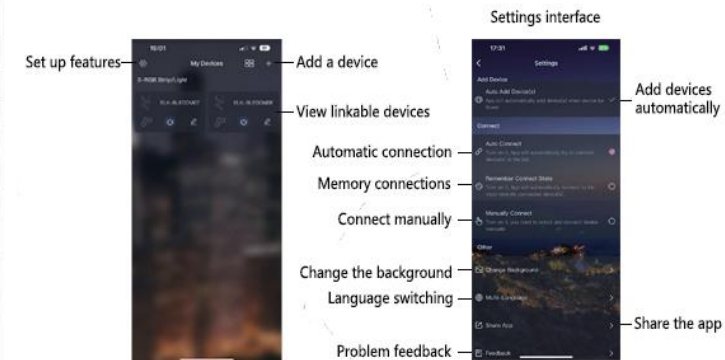

3

Clicking on the connected device will appear as shown in the dashboard image on the right.

Tap Connected devices

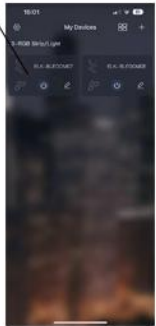

Displays the connection status



Pull the ring to switch colors

Color selection

Color addition

Brightness adjustment

Timing function

Power on and off

Scene selection

Static color

Vibration function

Mode selection

2. Use the color palette function when connecting devices.



- (1). Drag the ring to switch colors
- (2). Click on the RGB value to adjust the color
- (3). Tap Color to toggle
- (4). Click Pattern + and press (1) to perform color DIY  
(Long press DIY color to redo color DIY)
- (5). Drag the white point to adjust the brightness

4

3. Use the rhythm function when connecting the device.



(1) Device MIC: Sound rhythm is received through the device

(Four rhythm modes can be selected under the receiving sound rhythm through the device)

(2) Phone MIC: Receive sound rhythm via your phone

(3) Music: By selecting a music groove

(4) Sensitivity: Drag the white point to adjust the receive responsiveness

4. Use the mode function when connecting the device.



Swipe / tap the screen to switch static colors or jump changes and other functions

Slide the white dot to adjust the flashing speed in the changing state

Slide the white dot to adjust the brightness

5

5. Use scene features when connecting devices.

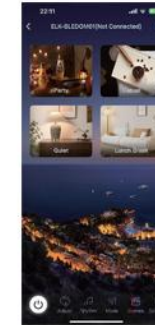

The scene function intelligently adjusts the flickering effect according to the system.

6. Use the timing function when connecting the device.

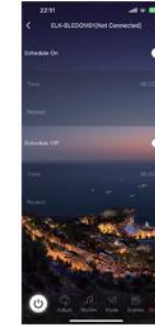

Turn on the lights regularly

Set the auto-start time and date by clicking to select

Turn off the lights regularly

Set the automatic lights off time and date by clicking to select

The timing function can be used together in other modes.

6



**NOWD Testing Services Co., Ltd.**

TEL: +86-755-2783 0065 FAX: +86-755-2783 0095

ADD: 5A, Building 29B, Yintian Industrial Zone, Yantian Community,  
Xixiang Street, Bao'an District, Shenzhen, China

Email: nowd@nowd.com.cn

Web: http://www.nowd.com.cn

## Verification of Compliance

**Reference** : NTS2511016  
**Report No.** : NTS2511016E, NTS2511017E, NTS2511018E, NTS2511019E  
**Applicant** : QingDao ChengKong Electrical-Auto Co., Ltd  
No.147 Xining Road, Zhuhai Community, Huangdao District, Qingdao, Shandong  
**Manufacture** : QingDao ChengKong Electrical-Auto Co., Ltd  
No.147 Xining Road, Zhuhai Community, Huangdao District, Qingdao, Shandong  
**Product** : LED STRIPT LIGHT  
**Trade Mark** : ROOZMAUSY  
**Model No.** : L-50-30D  
**Serial Model** : L-50-60D, L-50-18D, L-50-120D, L-3528-30D, L-3535-30D

The submitted sample of the above equipment has been tested for CE marking according to the following European Directives:

**Radio Equipment Directive:** 2014/53/EU

Standard(s) used for showing compliance with the essential requirements in the specified directive(s):

<b>Test Standards</b>	ETSI EN 301 489-1 V2.2.3 (2019-11)	EN 62479:2010
	ETSI EN 301 489-17 V3.2.4 (2020-09)	ETSI EN 300 328 V2.2.2 (2019-07)
	EN IEC 55015:2019+A11:2020	EN IEC 60598-2-1-2021
	EN IEC 61547-2023	used in conjunction with
	EN IEC 61000-3-2:2019+A1:2021+A2:2025	EN IEC 60598-1:2024/A11:2024
	EN 61000-3-3:2013+A1:2019+A2:2021	

The statement is based on a single evaluation of one sample of above mentioned products. It does not imply an assessment of the whole production.

The manufacture should ensure that all products in series production are in conformity with the product sample detailed in this report. The applicant should hold the whole technical report at disposal of the competent all the right.



Signed for and on behalf of  
**NOWD Testing Services Co., Ltd.**

Somnus  
Technical Manager

Date: November 8, 2025



**NOWD Testing Services Co., Ltd.**

TEL: +86-755-2783 0065 FAX: +86-755-2783 0095

ADD: 5A, Building 29B, Yintian Industrial Zone, Yantian Community,  
Xixiang Street, Bao'an District, Shenzhen, China

Email: nowd@nowd.com.cn

Web: <http://www.nowd.com.cn>

## Verification of Compliance

**Reference** : NTS2511017  
**Report No.** : NTS2511017E  
**Applicant** : QingDao ChengKong Electrical-Auto Co., Ltd  
No.147 Xining Road, Zhuhai Community, Huangdao District, Qingdao, Shandong  
**Manufacture** : QingDao ChengKong Electrical-Auto Co., Ltd  
No.147 Xining Road, Zhuhai Community, Huangdao District, Qingdao, Shandong  
**Product** : LED STRIPT LIGHT  
**Trade Mark** : ROOZMAUSY  
**Model No.** : L-50-30D  
**Serial Model** : L-50-60D, L-50-18D, L-50-120D, L-3528-30D, L-3535-30D

The submitted sample of the above equipment has been tested for CE marking according to the following European Directives:

The EMC Directive 2014/30/EU has been taken as references for these processes.  
Standard(s) used for showing compliance with the essential requirements in the specified directive(s):

<b>Test Standards</b>	ETSI EN 301 489-1 V2.2.3 (2019-11)	EN 62479:2010
	ETSI EN 301 489-17 V3.2.4 (2020-09)	ETSI EN 300 328 V2.2.2 (2019-07)
	EN IEC 55015:2019+A11:2020	EN IEC 60598-2-1-2021
	EN IEC 61547-2023	used in conjunction with
	EN IEC 61000-3-2:2019+A1:2021+A2:2025	EN IEC 60598-1:2024/A11:2024
	EN 61000-3-3:2013+A1:2019+A2:2021	

*The statement is based on a single evaluation of one sample of above mentioned products. It does not imply an assessment of the whole production.*

*The manufacture should ensure that all products in series production are in conformity with the product sample detailed in this report. The applicant should hold the whole technical report at disposal of the competent all the right.*



Signed for and on behalf of  
**NOWD Testing Services Co., Ltd.**

Somnus  
Technical Manager

Date: November 8, 2025



**NOWD Testing Services Co., Ltd.**

TEL: +86-755-2783 0065 FAX: +86-755-2783 0095

ADD: 5A, Building 29B, Yintian Industrial Zone, Yantian Community,  
Xixiang Street, Bao'an District, Shenzhen, China

Email: nowd@nowd.com.cn

Web: http://www.nowd.com.cn

## Verification of Compliance

**Reference** : NTS2511019  
**Report No.** : NTS2511019E  
**Applicant** : QingDao ChengKong Electrical-Auto Co., Ltd  
No.147 Xining Road, Zhuhai Community, Huangdao District, Qingdao,Shandong  
**Manufacture** : QingDao ChengKong Electrical-Auto Co., Ltd  
No.147 Xining Road, Zhuhai Community, Huangdao District, Qingdao,Shandong  
**Product** : LED STRIPT LIGHT  
**Trade Mark** : ROOZMAUSY  
**Model No.** : L-50-30D  
**Serial Model** : L-50-60D, L-50-18D, L-50-120D, L-3528-30D, L-3535-30D

**The submitted sample of the above equipment has been tested for CE marking according to the following European Directives:**

The Low Voltage Directive 2014/35/EU has been taken as references for these processes  
*Standard(s) used for showing compliance with the essential requirements in the specified directive(s):*

<b>Test Standards</b>	ETSI EN 301 489-1 V2.2.3 (2019-11)	EN 62479:2010
	ETSI EN 301 489-17 V3.2.4 (2020-09)	ETSI EN 300 328 V2.2.2 (2019-07)
	EN IEC 55015:2019+A11:2020	EN IEC 60598-2-1-2021
	EN IEC 61547-2023	<b>used in conjunction with</b>
	EN IEC 61000-3-2:2019+A1:2021+A2:2025	EN IEC 60598-1:2024/A11:2024
	EN 61000-3-3:2013+A1:2019+A2:2021	

*The statement is based on a single evaluation of one sample of above mentioned products. It does not imply an assessment of the whole production.*

*The manufacture should ensure that all products in series production are in conformity with the product sample detailed in this report. The applicant should hold the whole technical report at disposal of the competent all the right.*



Signed for and on behalf of  
**NOWD Testing Services Co., Ltd.**

Somnus  
Technical Manager

Date: November 8, 2025



**NOWD Testing Services Co., Ltd.**

TEL: +86-755-2783 0065 FAX: +86-755-2783 0095

ADD: 5A, Building 29B, Yintian Industrial Zone, Yantian Community,  
Xixiang Street, Bao'an District, Shenzhen, China

Email: nowd@nowd.com.cn

Web: <http://www.nowd.com.cn>

## Verification of Compliance

**Reference No.** : NTS2511070  
**Report No.** : NTS2511070R  
**Applicant** : QingDao ChengKong Electrical-Auto Co., Ltd  
No.147 Xining Road, Zhuhai Community, Huangdao District, Qingdao, Shandong  
**Manufacturer** : QingDao ChengKong Electrical-Auto Co., Ltd  
No.147 Xining Road, Zhuhai Community, Huangdao District, Qingdao, Shandong  
**Product** : LED STRIPT LIGHT  
**Model No.** : L-50-30D, L-50-60D, L-50-18D, L-50-120D, L-3528-30D, L-3535-30D  
**Trade Mark** : N/A

**The submitted sample of the above equipment has been tested for CE marking according to the following European Directives:**

**RoHS Directive: 2011/65/EU & 2015/863/EU**

*Standard(s) used for showing compliance with the essential requirements in the specified directive(s):*

<b>Test Standards</b>	<b>IEC 62321-1: 2013;</b>	<b>IEC 62321-6: 2015;</b>
	<b>IEC 62321-3-1: 2013;</b>	<b>IEC 62321-7-1: 2015;</b>
	<b>IEC 62321-4: 2013+A1: 2017;</b>	<b>IEC 62321-7-2: 2017;</b>
	<b>IEC 62321-5: 2013;</b>	<b>IEC 62321-8: 2017</b>

*The statement is based on a single evaluation of one sample of above mentioned products. It does not imply an assessment of the whole production.*

*The manufacturer should ensure that all products in series production are in conformity with the product sample detailed in this report. The applicant should hold the whole technical report at disposal of the competent all the right.*

# RoHS



Signed for and on behalf of  
**NOWD Testing Services Co., Ltd.**

Somnus

Technical Manager

Date: Nov. 08, 2025



This certificate is responsible for testing sample only.  
Please refer to this corresponding test report to get testing process and data.

# CERTIFICATE

## ATTESTATION Certificate of Compliance

Technical file of the company mentioned below has been inspected and audit has been completed successfully

The Low Voltage Directive 2014/35/EU has been taken as references for these processes.

Certificate's Holder : QingDao ChengKong Electrical-Auto Co., Ltd.  
Address : Room 5-402, No.147 Xining Road, Zhuhai Community, Huangdao District, Qingdao, Shandong, China  
Manufacturer : QingDao ChengKong Electrical-Auto Co., Ltd.  
Address : Room 5-402, No.147 Xining Road, Zhuhai Community, Huangdao District, Qingdao, Shandong, China  
Product Name : Furniture Power Distribution Unit  
Product Model (S) : JN02-00-22, JN02-00-22Y, JN02-00-02, JN02-00-21, JN02-00-23, JN02-00-03, JN02-00-04  
Trade Mark : Roozmausy  
Related Directive : 2014/35/EU  
Related Standards : EN IEC 62368-1:2020 + A11:2020  
Certificate Number : HK2405271322S  
Report No. : HK2405271322-SR  
Registration Date : Jun. 04, 2024



Certification Manager



The information of the certificate can be checked through [www.cer-mark.com](http://www.cer-mark.com). The CE mark which is shown on the certificate can only be used under the conditions that the products complete with all of the relevant Directives of CE Declaration of Conformity. The Manufacturer should be responsible for the internal production control so that the products complied with the essential requirements of the above mentioned Directive(s). Certificate holder must notify all changes to the original certification laboratory of HUAKE.



Shenzhen HUAKE Testing Technology Co., Ltd.

Add.: 1-2/F., Building B2, Junfeng Zhongcheng Zhizao Innovation Park, Heping, Fuhai Street, Bao'an District, Shenzhen, Guangdong, China  
Tel.: +86-755-2302 9901 Http:// [www.cer-mark.com](http://www.cer-mark.com) Postcode: 518103 E-mail: [service@cer-mark.com](mailto:service@cer-mark.com)



This certificate is responsible for testing sample only.  
Please refer to this corresponding test report to get testing process and data.

# CERTIFICATE

## ATTESTATION Certificate of Compliance

Technical file of the company mentioned below has been inspected and audit has been completed successfully

The EMC Directive 2014/30/EU has been taken as references for these processes.

Certificate's Holder : QingDao ChengKong Electrical-Auto Co., Ltd.  
 Address : Room 5-402, No.147 Xining Road, Zhuhai Community, Huangdao District, Qingdao, Shandong, China  
 Manufacturer : QingDao ChengKong Electrical-Auto Co., Ltd.  
 Address : Room 5-402, No.147 Xining Road, Zhuhai Community, Huangdao District, Qingdao, Shandong, China  
 Product Name : Furniture Power Distribution Unit  
 Product Model (S) : JN02-00-22, JN02-00-22Y, JN02-00-02, JN02-00-21, JN02-00-23, JN02-00-03, JN02-00-04  
 Trade Mark : Roozmausy  
 Related Directive : 2014/30/EU  
 EN 55032:2015 + A1:2020 + A11:2020  
 Related Standards : EN IEC 61000-3-2:2019 + A1:2021  
 EN 61000-3-3:2013 + A1:2019 + A2:2021  
 EN 55035:2017 + A11:2020

Certificate Number : HK2405272729E  
 Report No. : HK2405272729-1ER  
 Registration Date : Jun. 04, 2024



Certification Manager



The information of the certificate can be checked through [www.cer-mark.com](http://www.cer-mark.com). The CE mark which is shown on the certificate can only be used under the conditions that the products complete with all of the relevant Directives of CE Declaration of Conformity. The Manufacturer should be responsible for the internal production control so that the products complied with the essential requirements of the above mentioned Directive(s). Certificate holder must notify all changes to the original certification laboratory of HUAKE.



Shenzhen HUAKE Testing Technology Co., Ltd.

Add.: 1-2/F., Building B2, Junfeng Zhongcheng Zhizao Innovation Park, Heping, Fuhai Street, Bao'an District, Shenzhen, Guangdong, China  
Tel.: +86-755-2302 9901 Http:// [www.cer-mark.com](http://www.cer-mark.com) Postcode: 518103 E-mail: [service@cer-mark.com](mailto:service@cer-mark.com)

Certificate NO.: LBTC230314130R

## Certificate of Compliance

### EU- Restriction of the use of certain hazardous substances(RoHS)-

**Report No.** : LBTC230314130R

**Applicant** : QingDao ChengKong Electrical-Auto Co., Ltd

**Address** : Zhuhai Community, Huangdao District, Qingdao ,  
Shandong ,China

**Manufacturer** : QingDao ChengKong Electrical-Auto Co., Ltd

**Address** : Zhuhai Community, Huangdao District, Qingdao ,  
Shandong ,China

**Product** : Power Adapter

**Model Model** : JN02-00-22 JN02-00-22Y JN02-00-02 JN02-00-21 JN02-00-23 JN02-00-03

**Trade Mark** : N/A

**Test Standards** EC 62321-3-1-2013

EC 62321-5-1-2013

EC 62321-4-2013+AMD1:2017

EC 62321-7-1:2015

EC 62321-7-2:2017

EC 62321-6:2015

The test results based on the above specified products comply with the EU RoHS 2 Directive 2011/65 / EU Appendix II Amendment Directive(EU)2015/863 as last amended by Directive (EU)2017/2102 limit requirements.

The test results apply only to the particular sample tested and to the specific tests carried out. Specifically to the sample investigated in our test reference number only.

Other relevant Directives have to be observed.

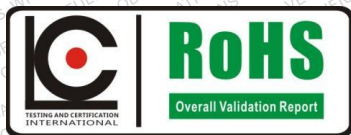

Chief Manager  
*Jiajie Su*  
LABTEST AUTHORIZED  
Date of Issue: Mar.14.2013

This statement is based on a single evaluation of the sample(s) of above mentioned product. It does not imply an assessment of the whole production.