

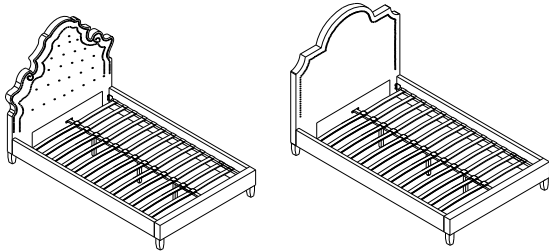







QUEEN BED

Before you start, here are some helpful advice:

1. We suggest you spend a short time reading through this leaflet and then follow the simple step-by-step instructions.
2. Owing to the size and weight of the bed, we recommend that it is assembled by two adults, on a carpeted or padded area, in the room that it is intended for. Approximate assembly time: 30 minutes.
3. Please do not use any tools other than those provided or recommended in these instructions.
4. Please do not throw away any of the packaging or the instruction until you have checked all the components and hardware and the furniture is fully assembled. Please ensure that the packaging is disposed of in a safe and environmentally friendly way.
5. Assemble all components loosely until advised to tighten. Depending on use, it may be necessary to tighten the components from time to time, so please save the tools that have been provided.
6. Please keep all fitting out of reach of children.



Hardware:

- | | | | |
|----|--|--------------|-----|
| A. |  | Bolt M8x70mm | x4 |
| B. |  | Bolt M8x25mm | x8 |
| C. |  | Bolt M8x20mm | x10 |
| D. |  | Flat Washer | x22 |
| E. |  | Lock Washer | x22 |
| F. |  | Allen Wrench | x1 |
| G. |  | Leg Plug | x4 |

Components:

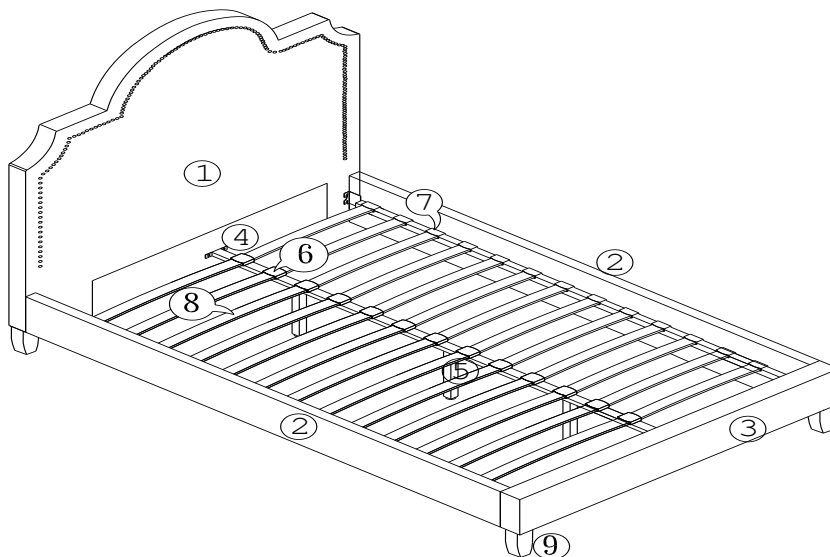

- | | | | | | | | | | |
|-------------------------|-----|-----------------------|-----|--------------|-----|----------------|----|-----------------------|----|
| 1. Headboard | x1 | 2. Bed rail | x2 | 3. Footboard | x1 | 4. Center rail | x1 | 5. Center Support leg | x3 |
| 6. Center Plastic Cover | x13 | 7. Side Plastic Cover | x26 | 8. Slat | x26 | 9. Leg | x4 | | |

QUEEN BED

STEP 1:

1. Attach the **Leg (9)** to **Headboard (1)** & **Footboard (3)** by using 4 pieces of **Bolts (A)**, 4 pieces of **Lock washer (E)** and 4 pieces of **Flat washers (D)**. Tighten **Bolts (A)** by using **Allen wrench (F)** fully as shown.
2. Insert 4 pieces of **Leg Plugs (G)** into **Legs (9)** after tighten all bolts in the leg as shown.

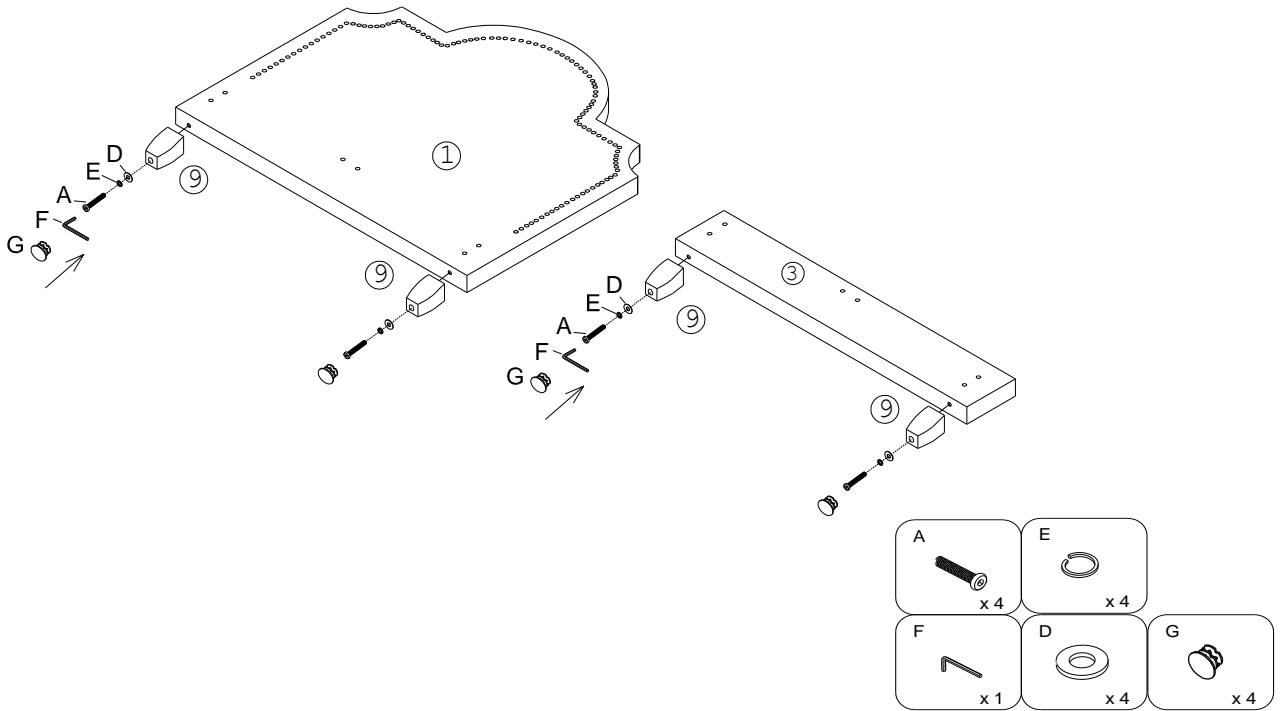

Hardware & Tools required

STEP 2:

- Attach one end of **Bed rail (2)** to **Headboard (1)** by using 2 pieces of **Bolts (B)**, 2 pieces of **Lock washers (E)** and 2 pieces of **Flat washers (D)**. Do not fully tighten **Bolts (B)** at this step.
- Repeat the same steps for the other end of **Bed rail (2)** to the **Footboard (3)**.
- Repeat the same steps for the other **Bed rail (2)** to **Headboard (1)** and **Footboard (3)**.
- Finally tighten all the **Bolts (B)** fully.

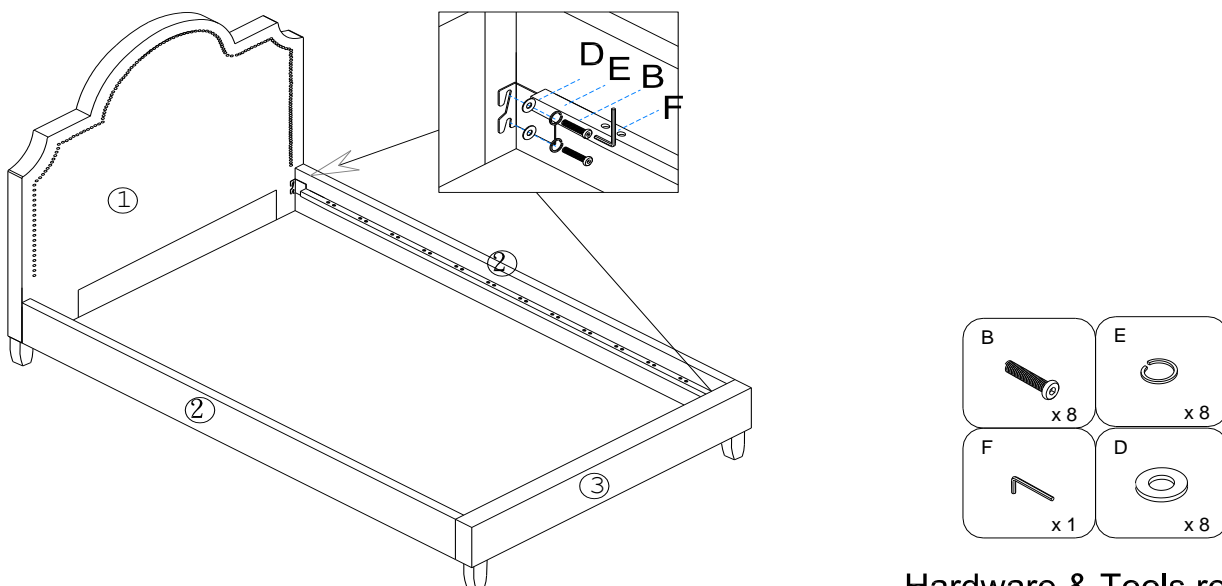

Hardware & Tools required

QUEEN BED

STEP 3:

1. Attach the **Center support leg (5)** to **Center rail (4)** by using 6 pieces of **Bolts (C)**, 6 pieces of **Lock washers (E)** and 6 pieces of **Flat washers (D)**. Tighten all **Bolts (C)** by using **Allen wrench (F)** as shown in Figure 1. Pls note there are adjustable foot glide on the bottom of **Center support leg (5)** and you can adjust the height if necessary.
2. Attach the assembled **Center rail (4)** and **Center support leg(5)** to Headboard &Footboard by using 4 pieces of **Bolts (C)**, 4 pieces of **Lock washers (E)** and 4 pieces of **Flat washers (D)**. Tighten **Bolts(C)** by using **Allen wrench (F)** as shown in Figure 2.

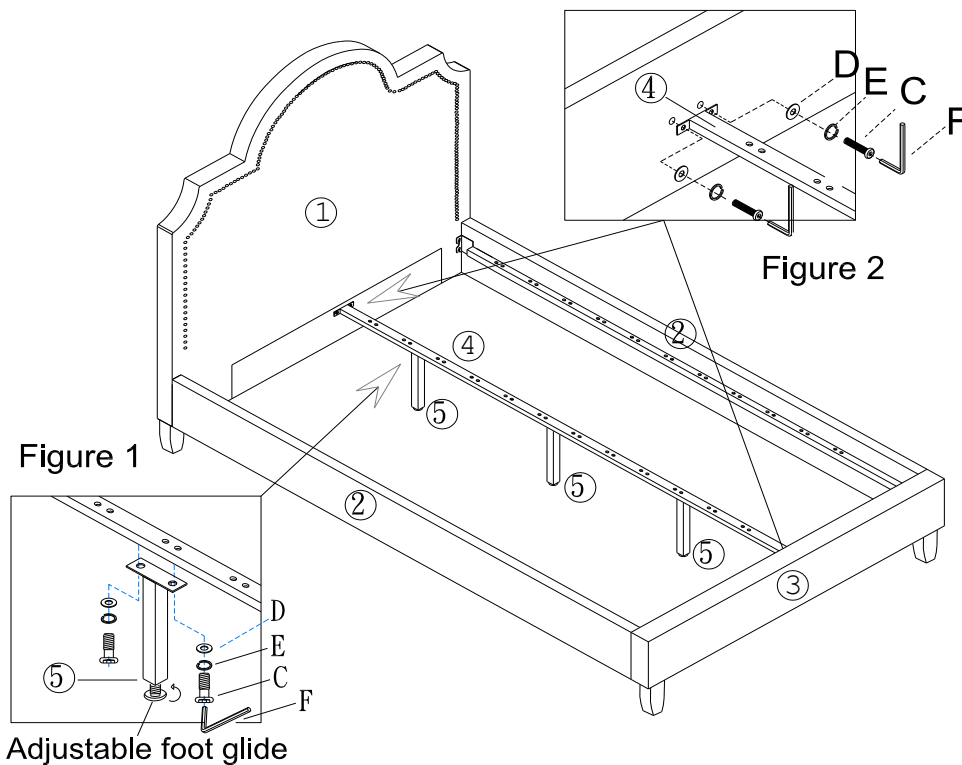

STEP 4:

- Insert 2 pieces of **Side Plastic Cover (7)** into each end of 2 pieces of **Slats (8)** as shown. Insert the other end of the **Slats (8)** into 1 piece of **Center Plastic Cover (6)** as shown. Insert the assembled **Side Plastic Covers (7)** into the corresponding holes on the Slat support of the **Bed rail (2)**, and the assembled **Center Plastic Cover (6)** into the corresponding holes on **Center Rail (4)** as shown. Repeat the same steps for the remaining 24 pieces of **Slats (8)**.

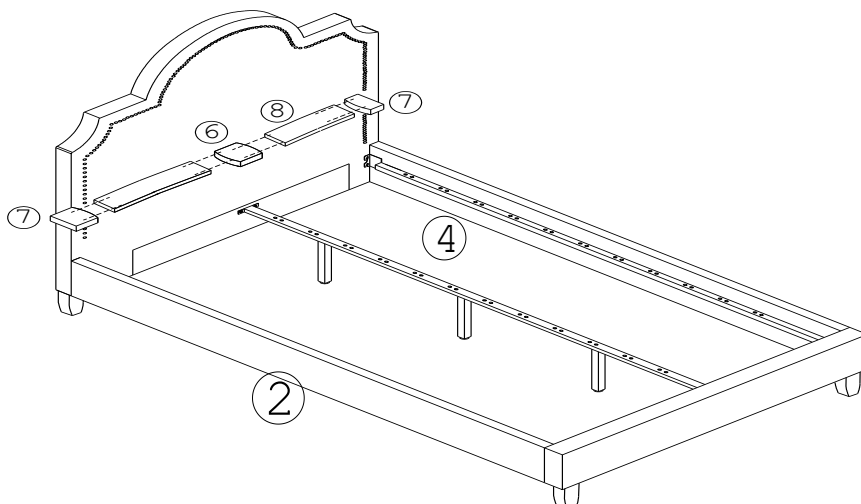

QUEEN BED

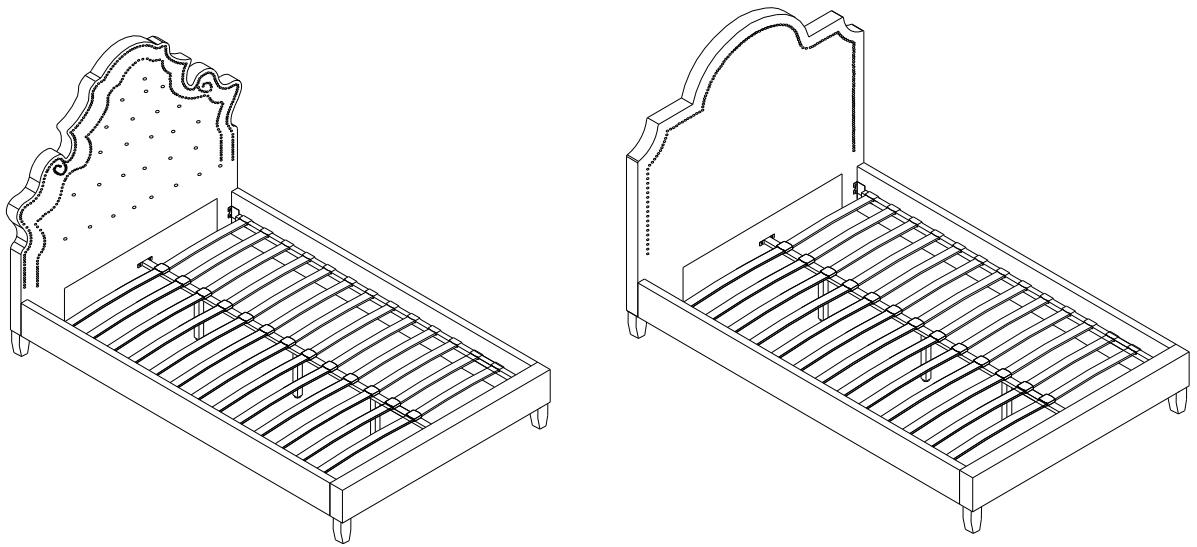

Assembly is complete. The Queen Bed is ready to enjoy now!