

**A** x1**B** x1**C** x1**D** x1**E** x1**F** x1**G** x1**H** x1**I** x1**J** x2**K** x1**L** x1**M** x1**N** x1**O** x4**P** x4**Q** x2**R** x2

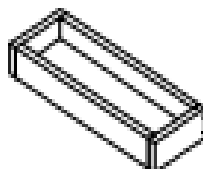
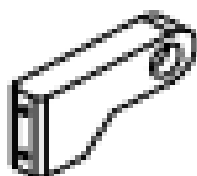
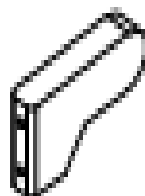
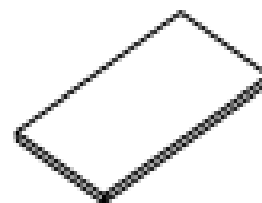
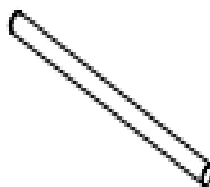
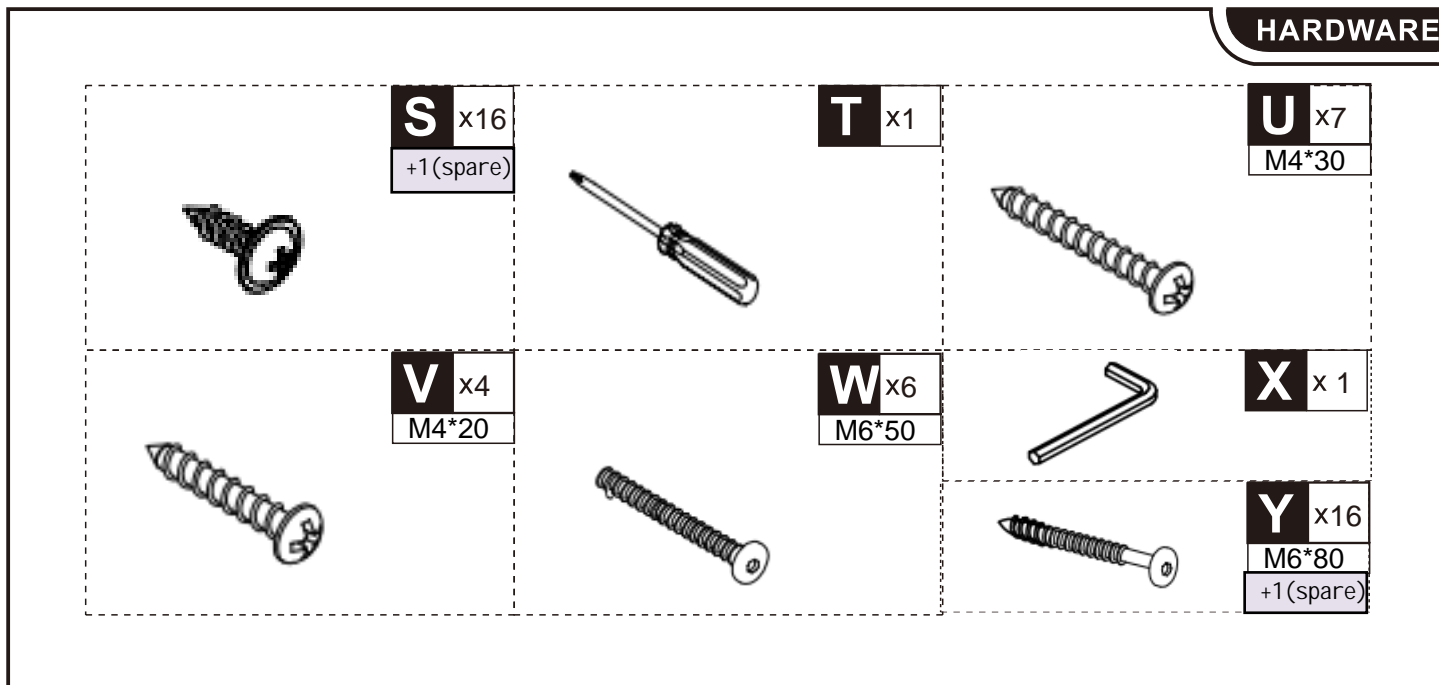

NOTE

EN_ Do not tighten bolts fully until all parts are connected!

FR_ Ne serrez pas les boulons à fond tant que toutes les pièces ne sont pas connectées!

ES_ No apriete los tornillos completamente hasta que todas las partes están conectadas!

PT_ Não apertar completamente os parafusos até que todas as peças estejam encaixadas!

DE_ Ziehen Sie die Schrauben erst fest an, wenn alle Teile verbunden sind!

IT_ non serrare completamente i bulloni fino a tutte le parti non sono ancora collegate!

1

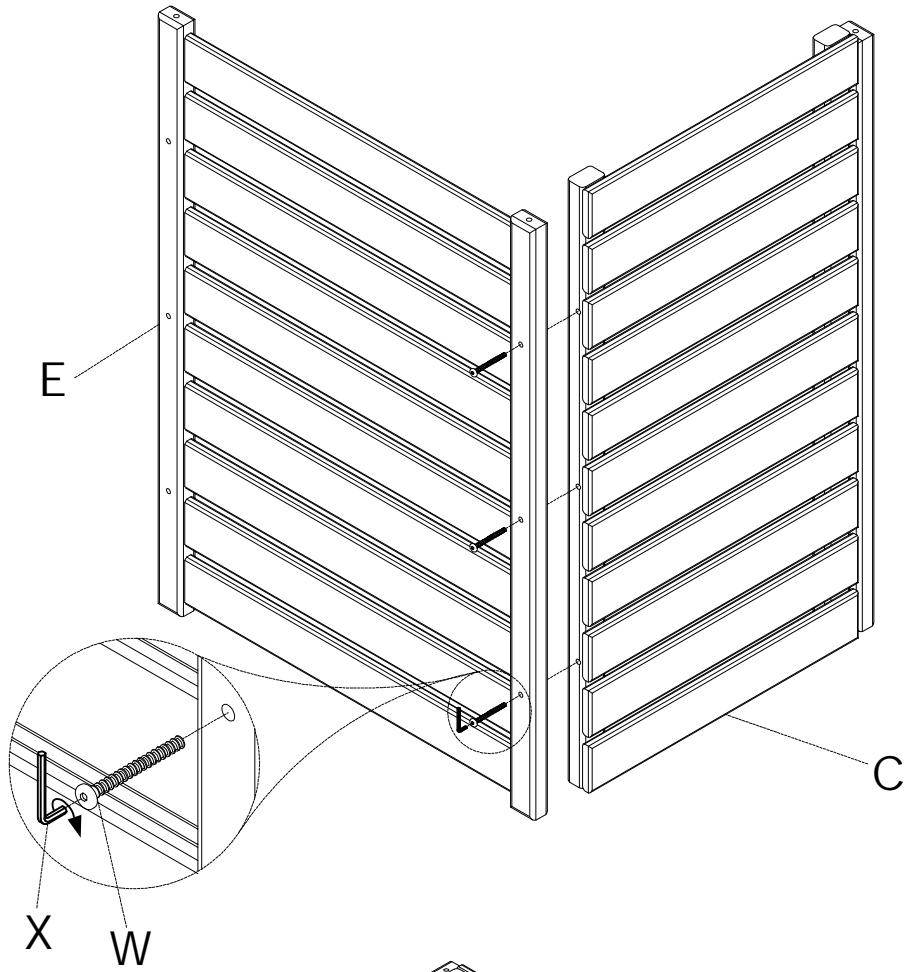

2

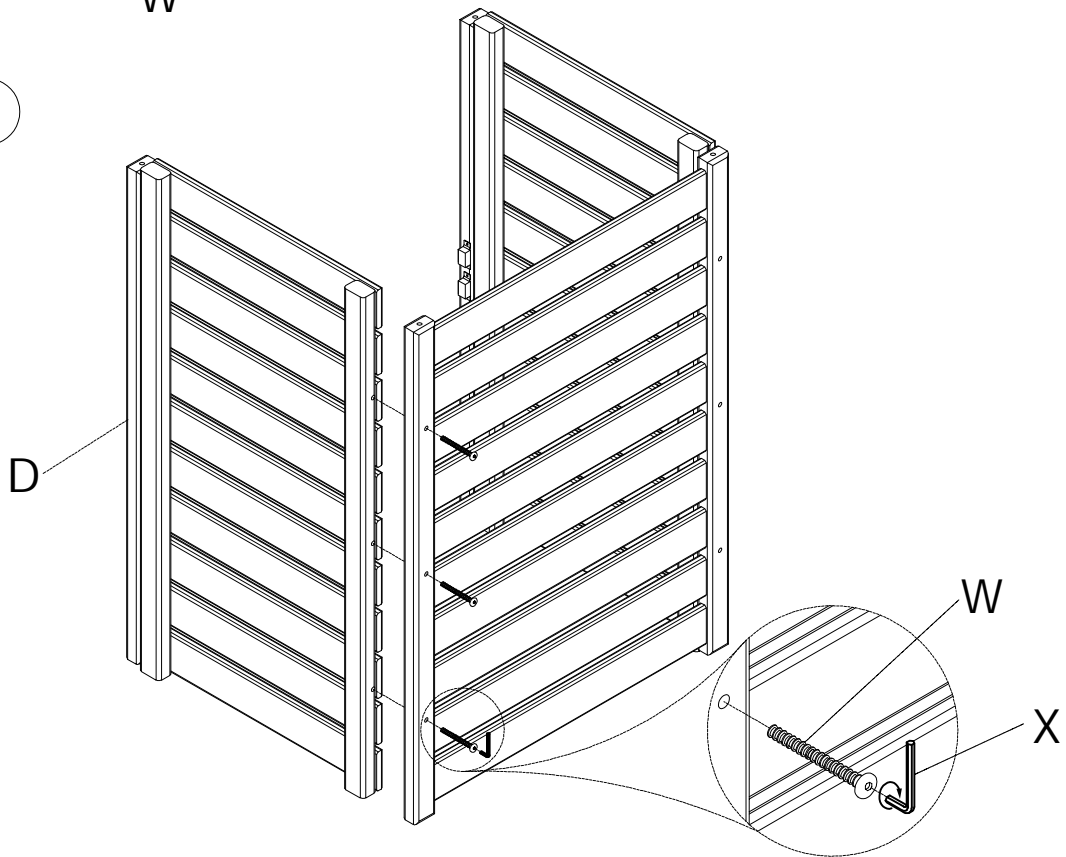

3

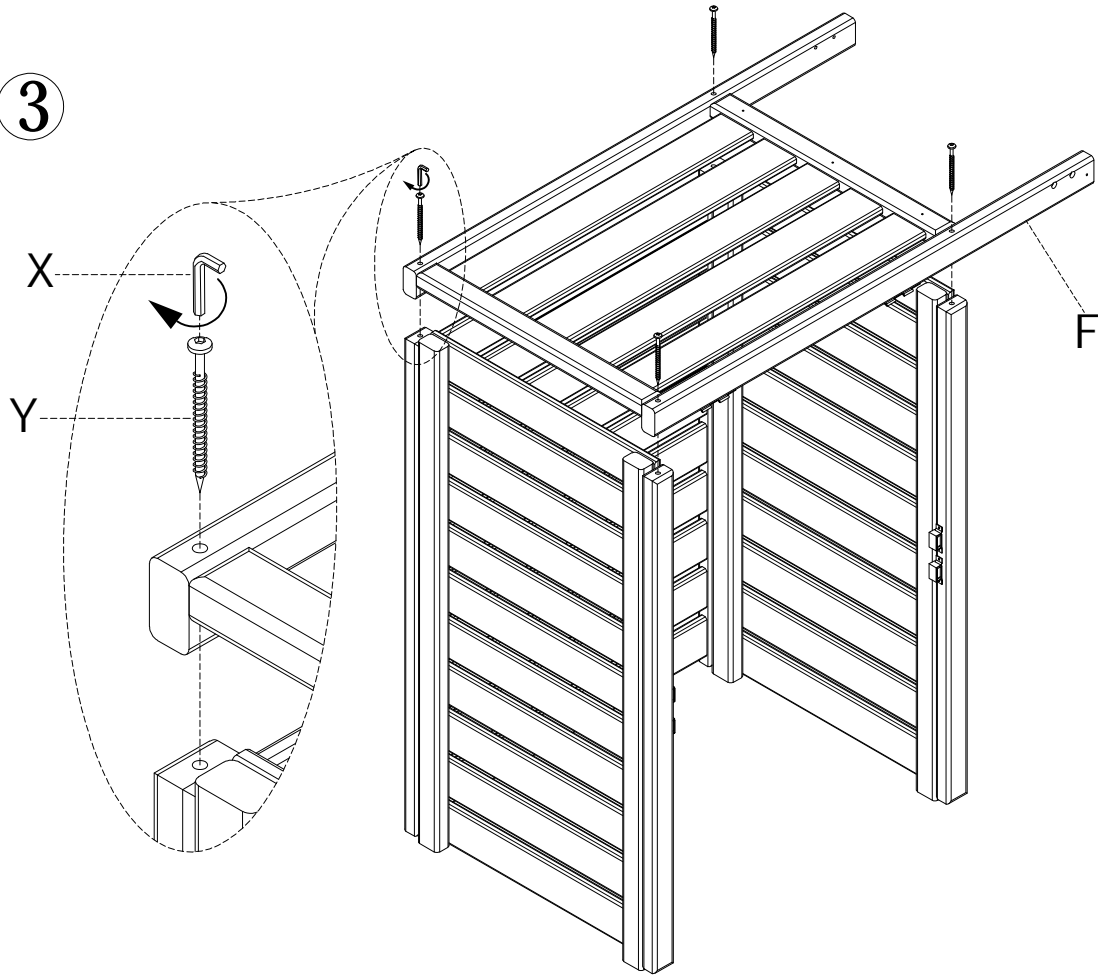

4

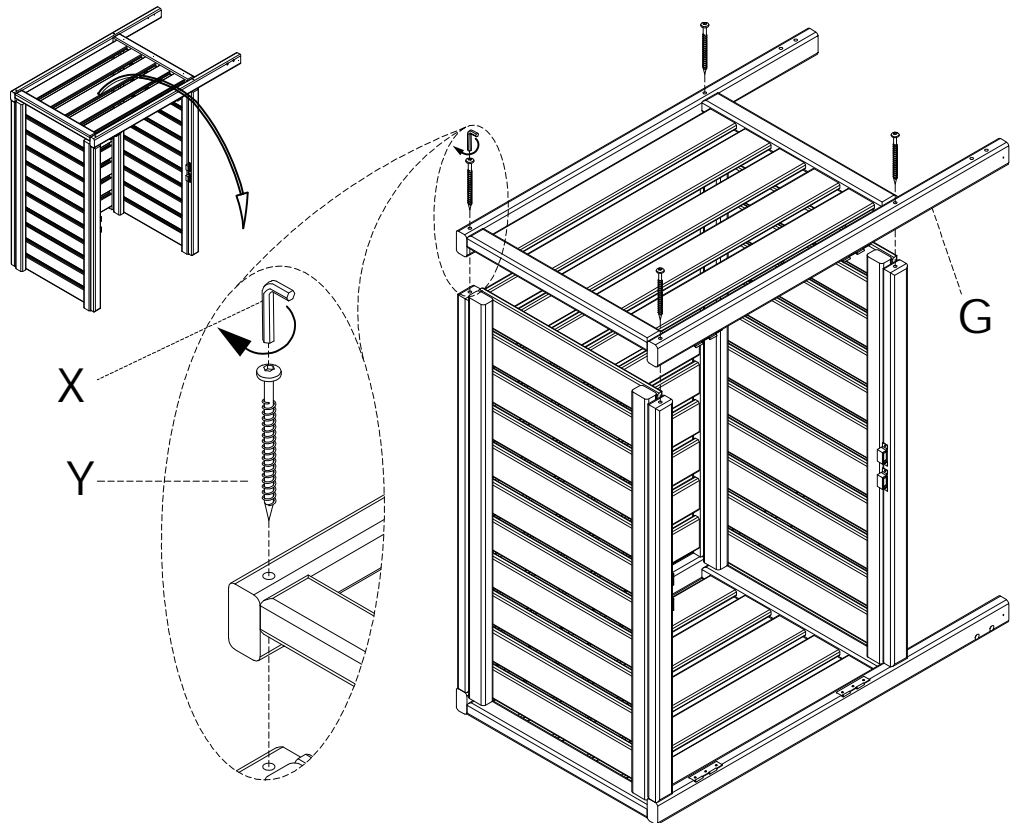

5

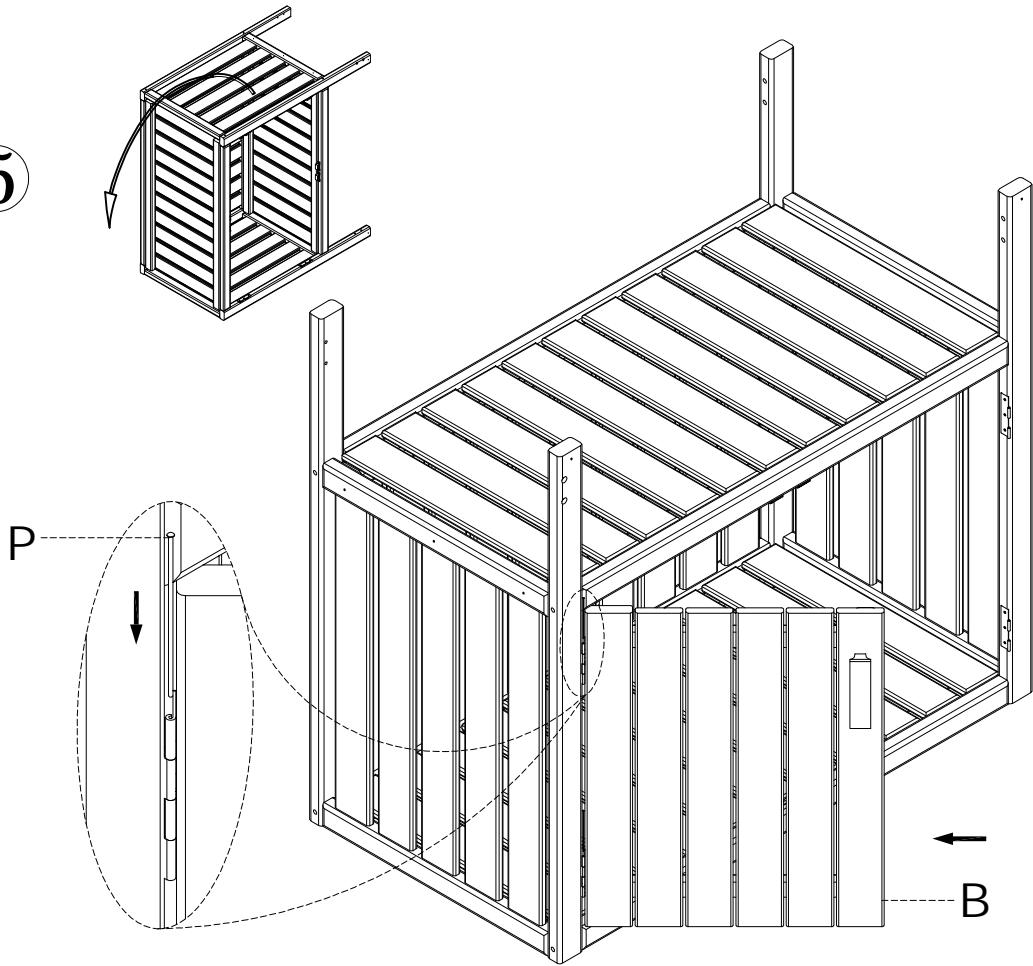

6

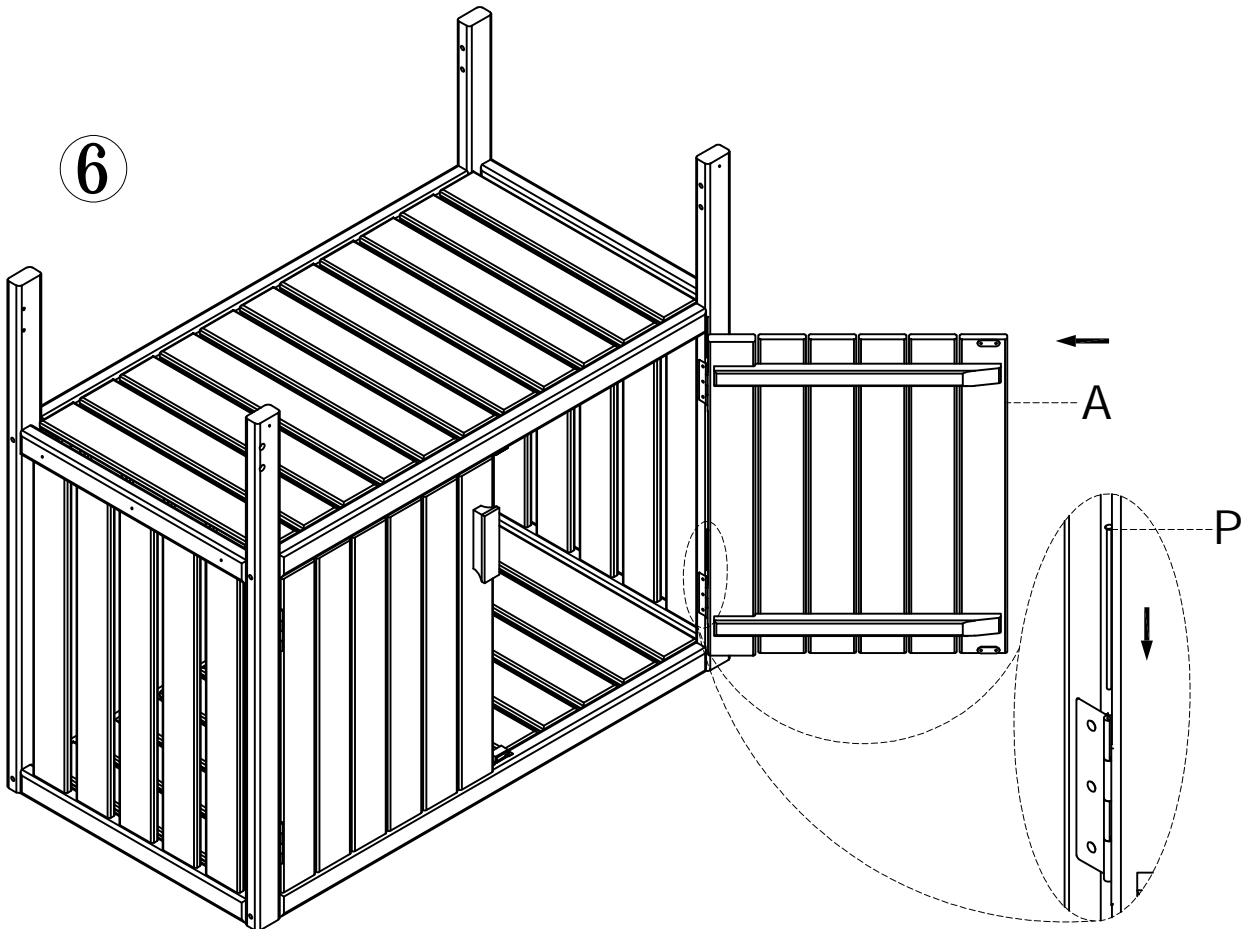

7

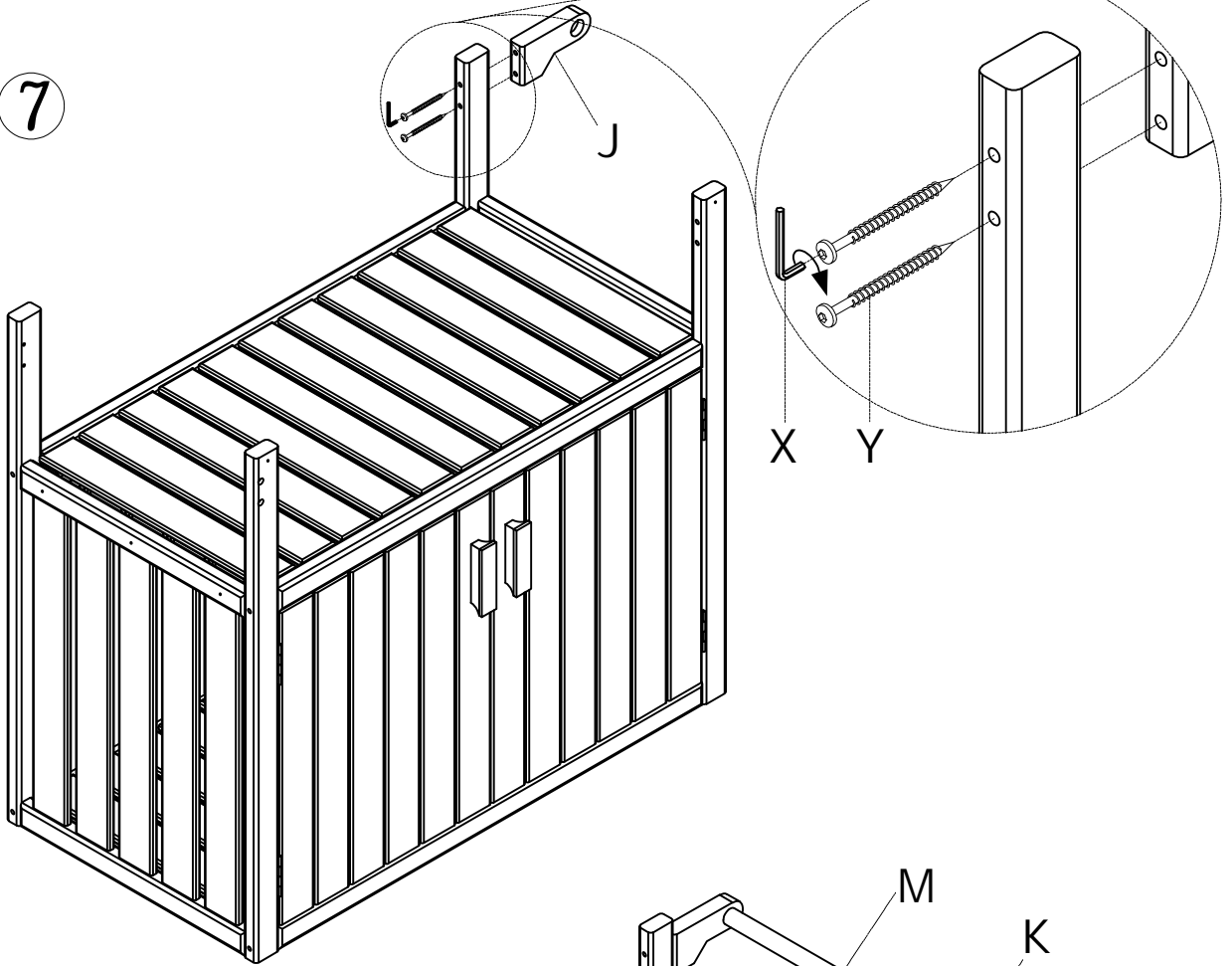

8

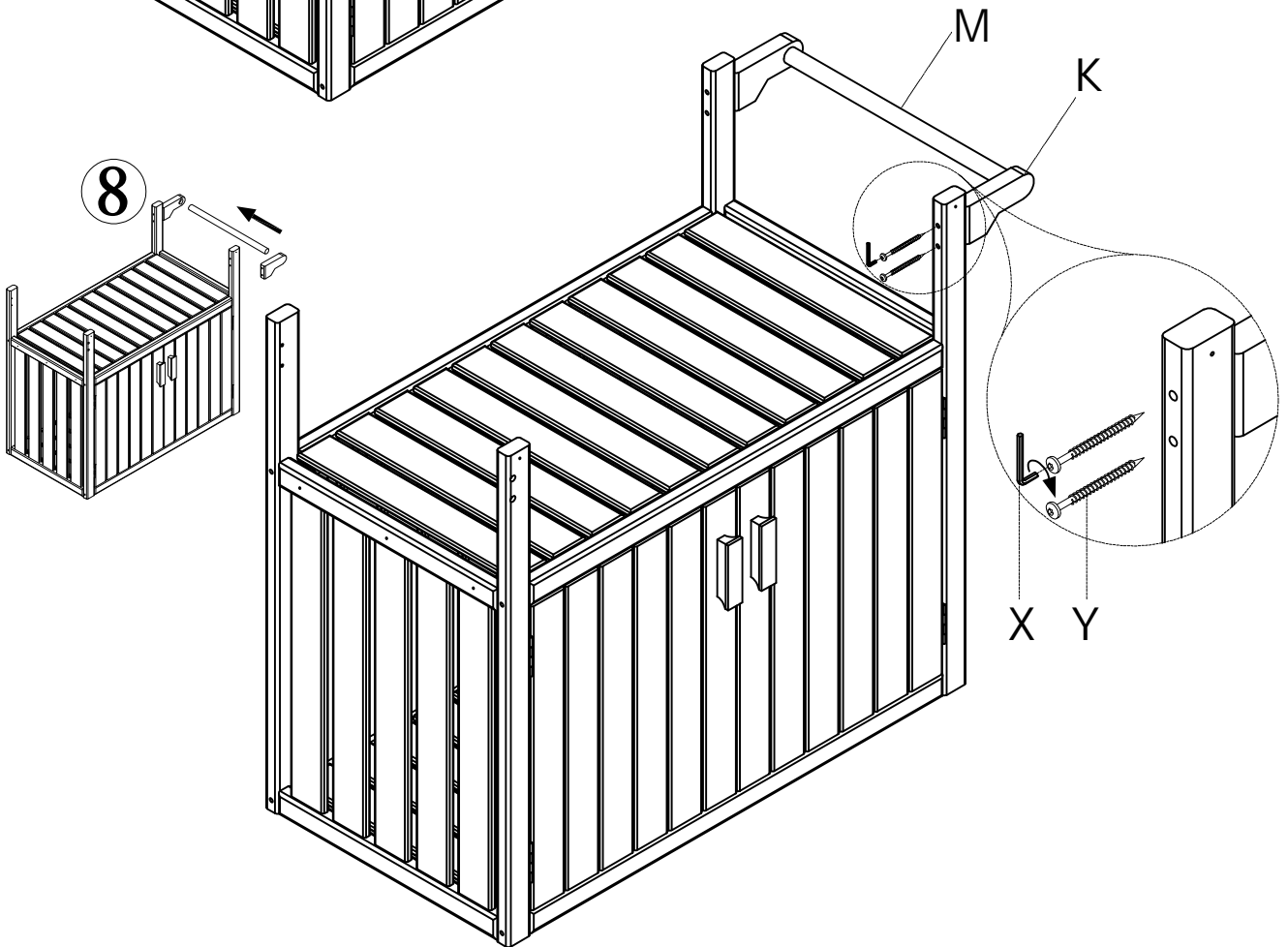

9

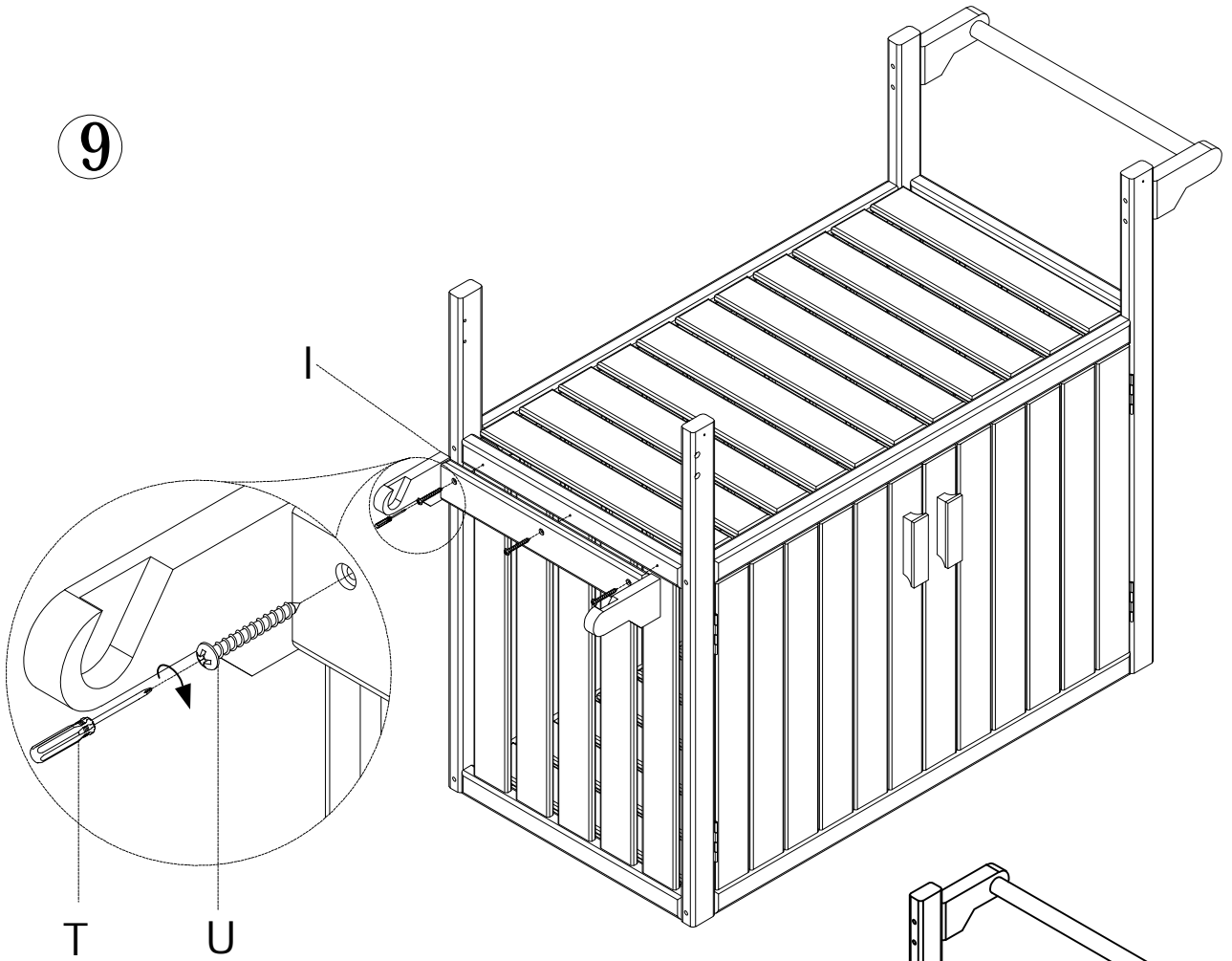

10

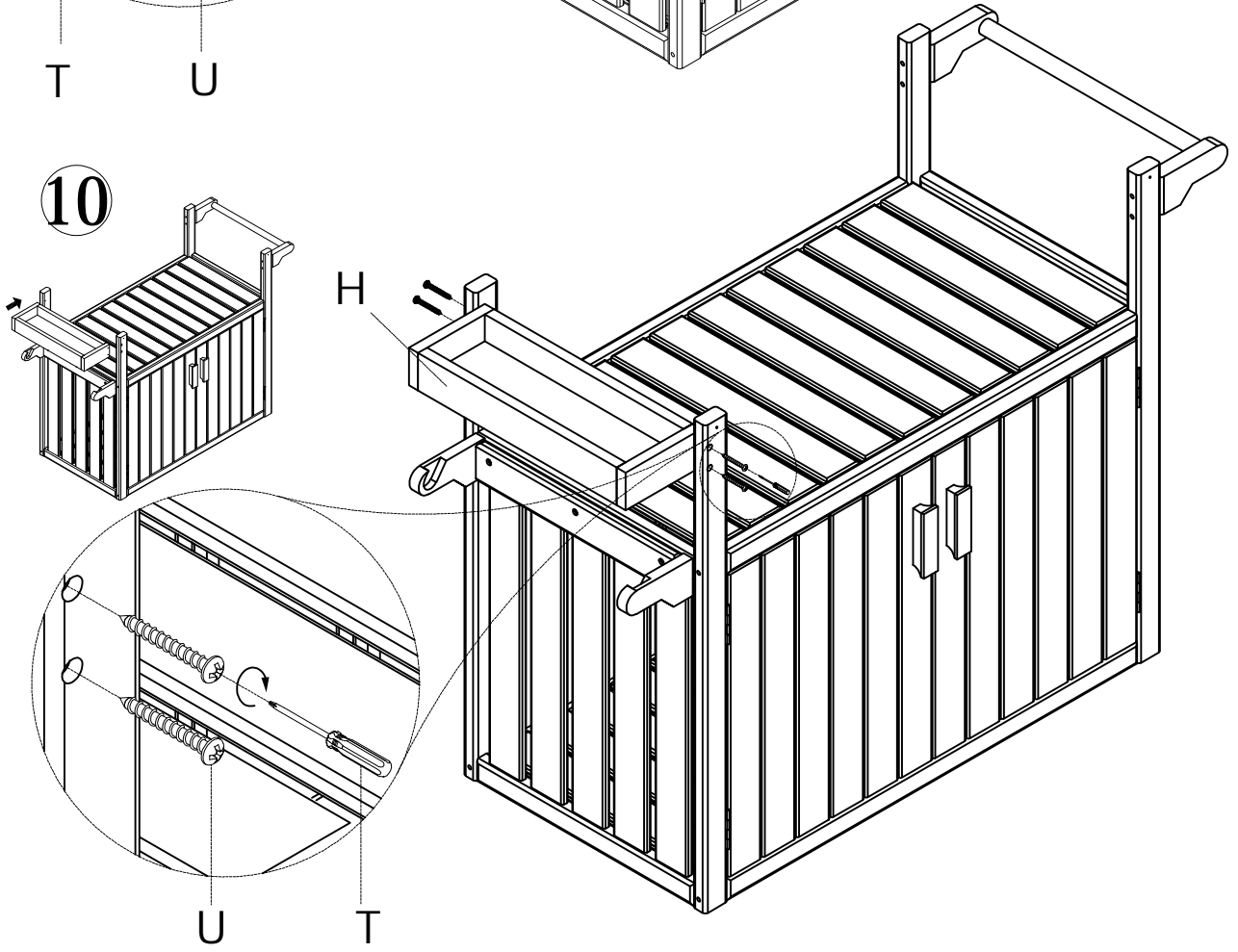

11

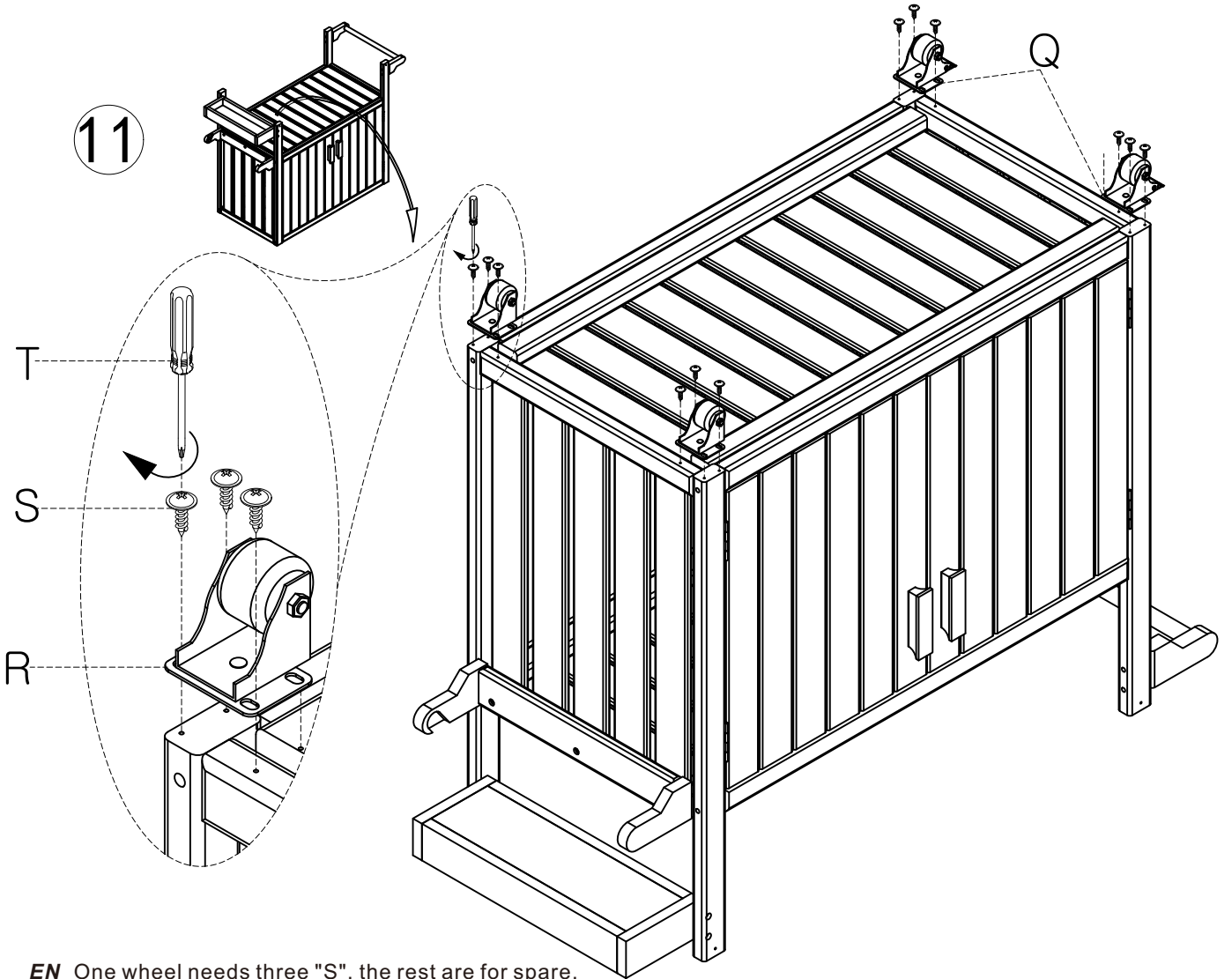

EN One wheel needs three "S", the rest are for spare.
FR Une roue a besoin de trois « S », les autres sont des roues de secours.
ES Una rueda necesita tres «S», el resto son de repuesto.
PT Uma roda precisa de três "S", as restantes são de reserva.
DE Für ein Rad werden drei „S“ benötigt, der Rest ist als Reserve gedacht.
IT Una ruota ha bisogno di tre "S", le altre sono di scorta.

12

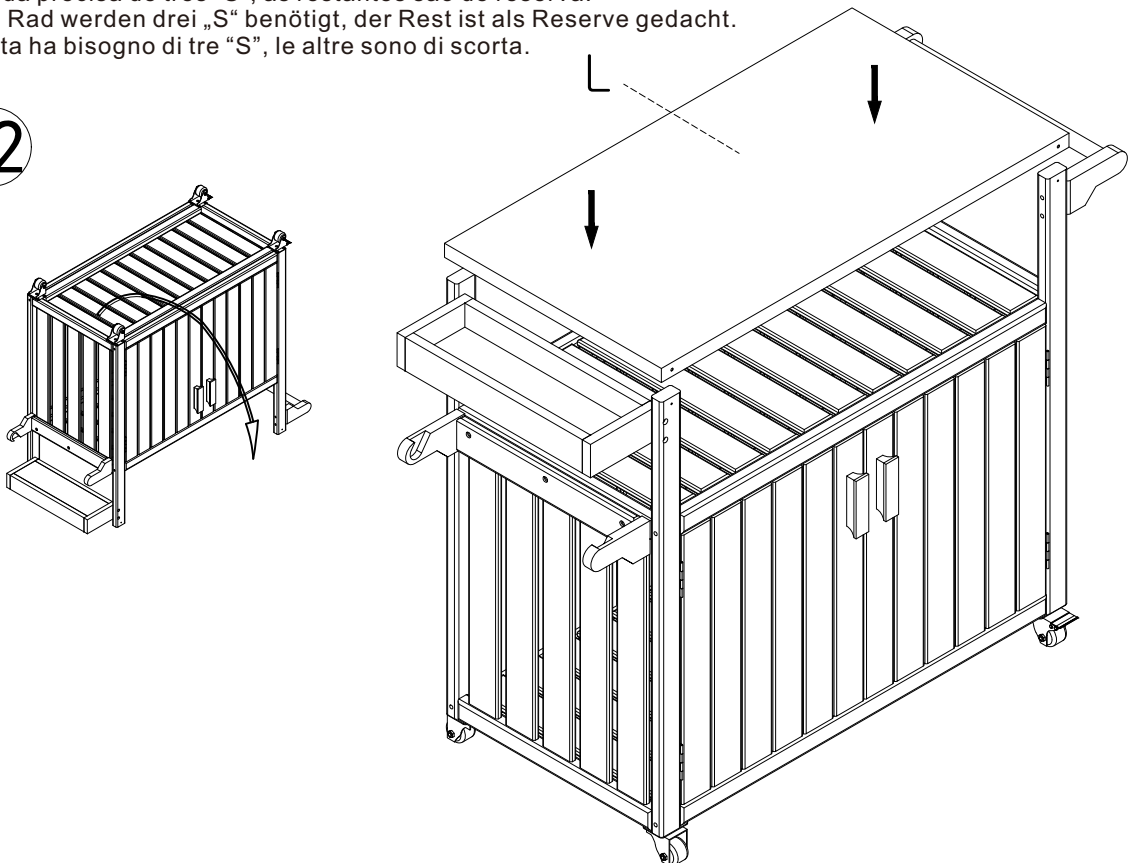

13

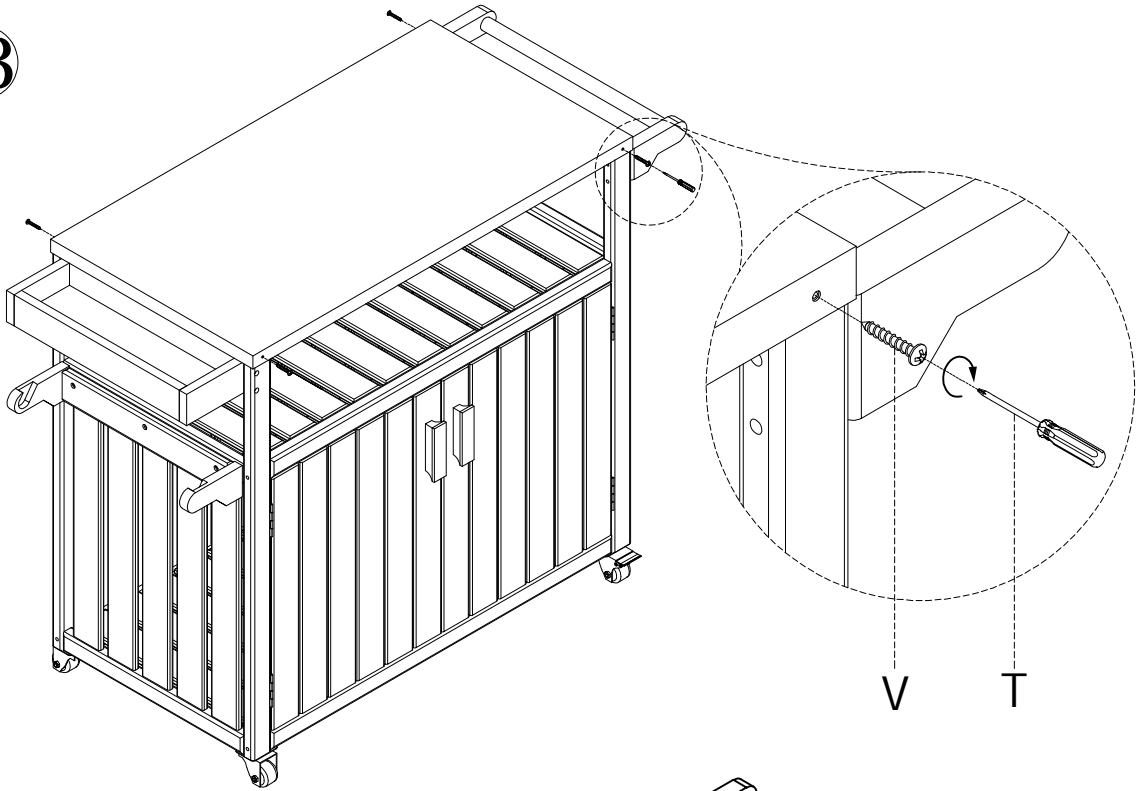

14

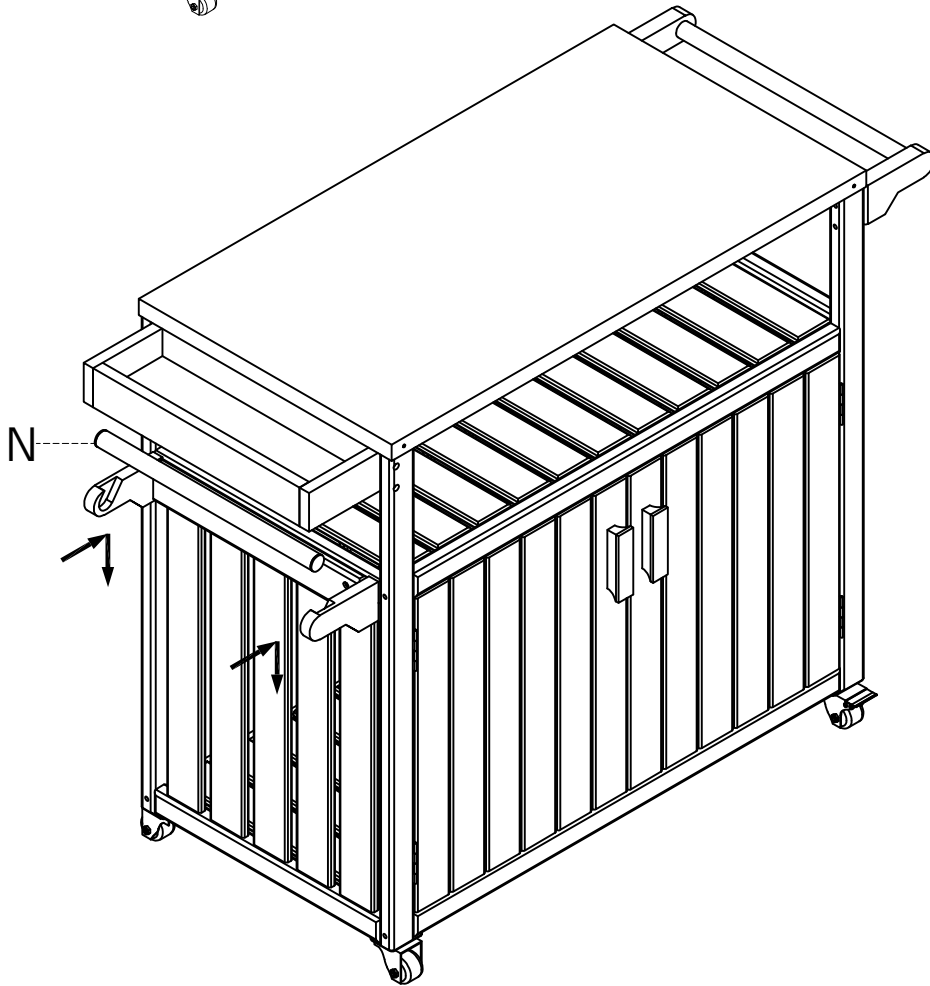

15

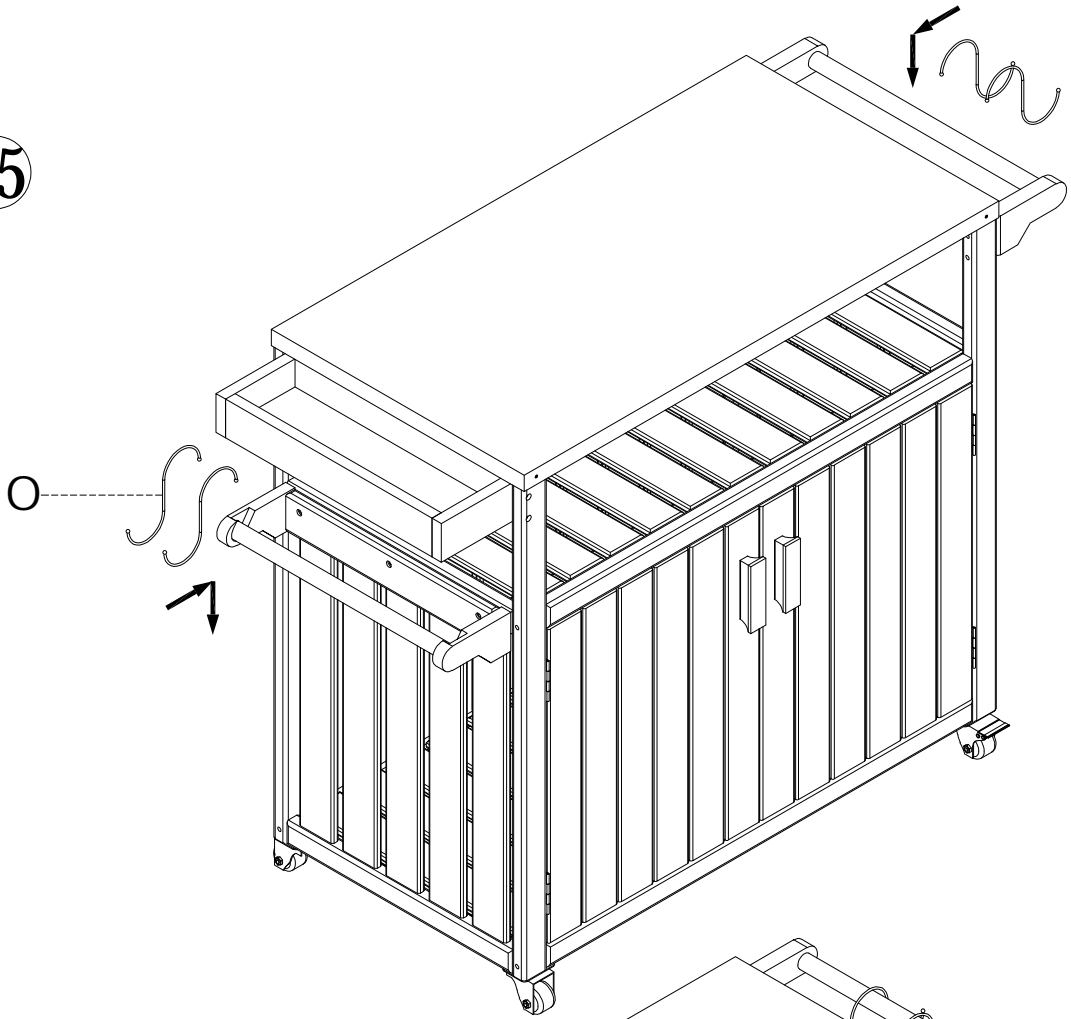

16

