

ASSEMBLY INSTRUCTION

DINING SET

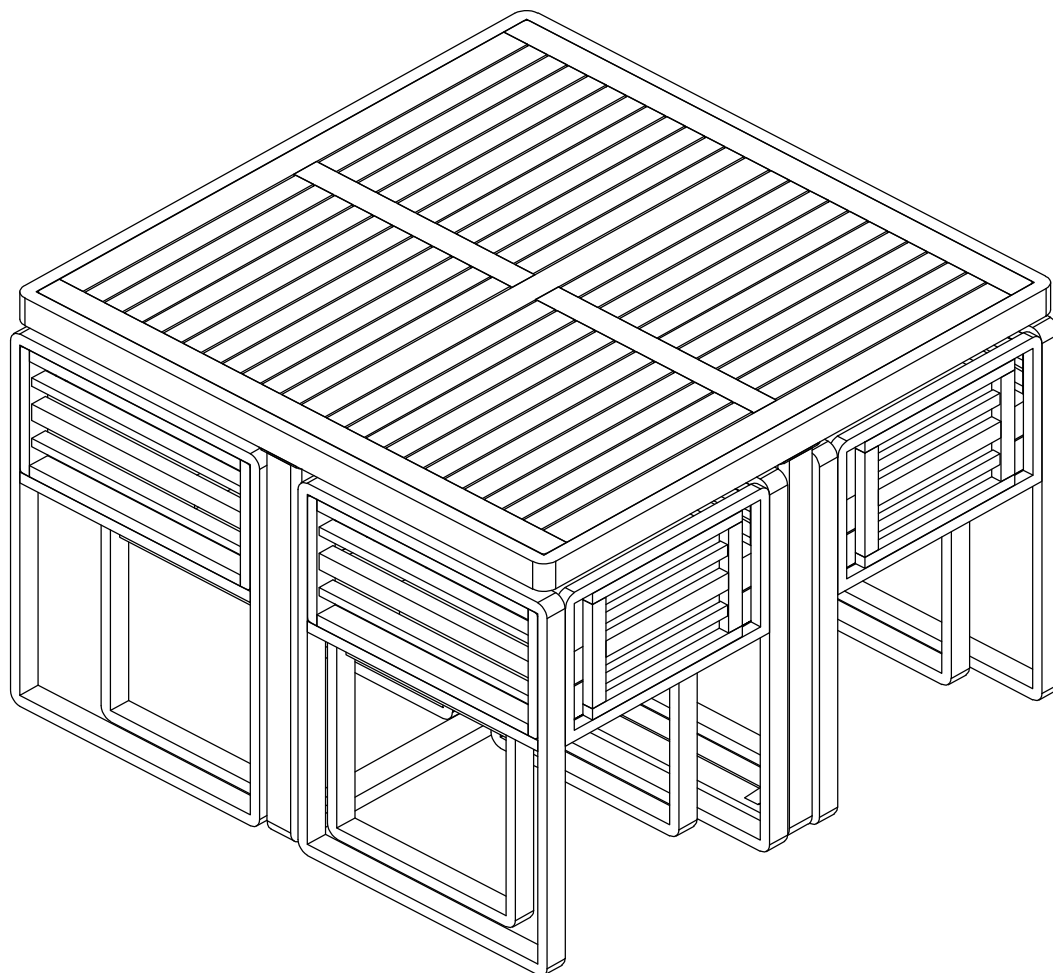

Notice:

- 1. 50% Tighten before fixing all screws, Allen wrench is recommended instead of an electric drill.**
- 2. Place the item on a flat ground to adjust and make sure it remains stable.**
- 3. Tighten up all screws with tools gradually.**
- 4. If the screws are not aligned with holes during assembly, please loosen all the other screws to 50% and continue the assembly process.**
- 5. If the item is not stable, please loosen all the screws, adjust it on a flat ground and tighten up all screws again.**
- 6. Note : If one or some screws are fully tightened during assembly, chances are the others will not be aligned with holes. In addition, all the holes are designed to be relatively larger to provide more space for the adjustment of the screws.**

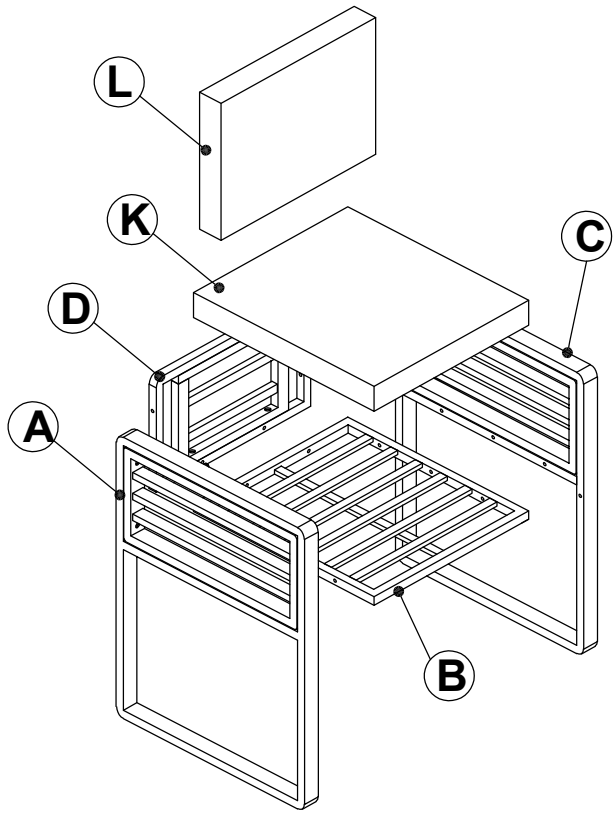

x4

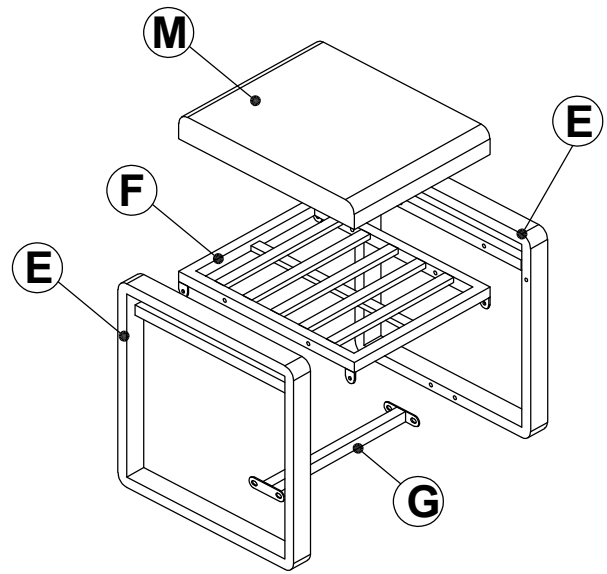

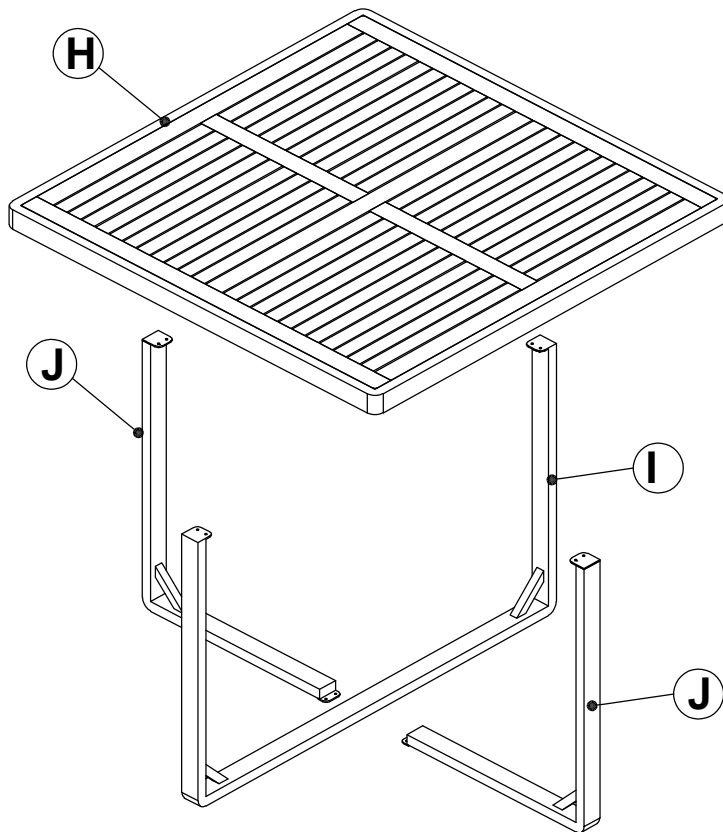

x4

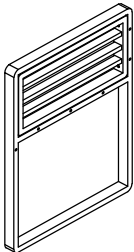
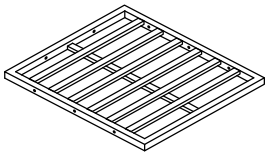
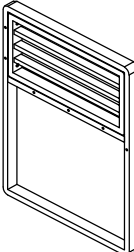
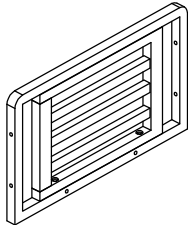
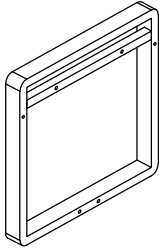
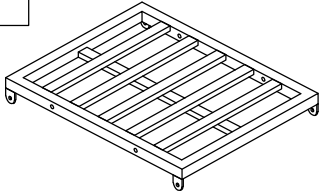
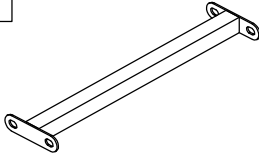
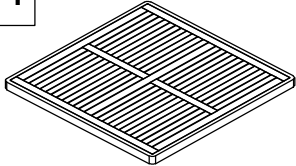
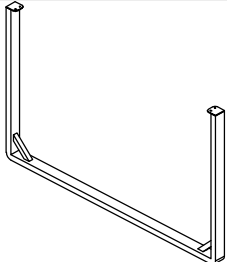
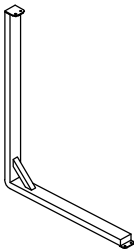
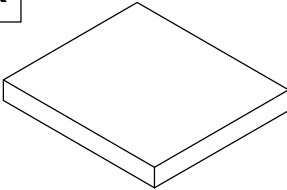
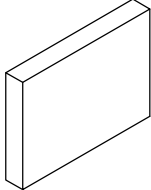
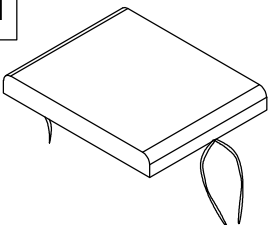

x1

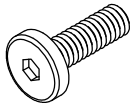
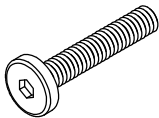
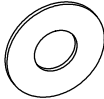
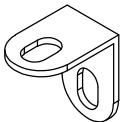
<p>A</p>  <p>Right Leg (4 pcs)</p>	<p>B</p>  <p>Seat Chair Frame (4 pcs)</p>	<p>C</p>  <p>Left Leg (4 pcs)</p>	<p>D</p>  <p>Back Chair Frame (4 pcs)</p>
<p>E</p>  <p>Leg Stool (8 pcs)</p>	<p>F</p>  <p>Seat Stool Frame (4 pcs)</p>	<p>G</p>  <p>Support stool (4 pcs)</p>	<p>H</p>  <p>Top Table (1 pc)</p>
<p>I</p>  <p>Table Leg Middle (1 pc)</p>	<p>J</p>  <p>Table Leg Left (2 pcs)</p>	<p>K</p>  <p>Seat Cushion (4 pcs)</p>	<p>L</p>  <p>Back Cushion (4 pcs)</p>
<p>M</p>  <p>Seat Stool Cushion (4 pcs)</p>			

<p>1 x 60 pcs</p>  <p>Extra 2 pcs BOLT M6 x 20MM</p>	<p>2 x 64 pcs</p>  <p>Extra 2 pcs BOLT M6 x 35MM</p>	<p>3 x 124 pcs</p>  <p>Extra 3 pcs FLAT WASHER M6</p>	<p>4 x 8 pcs</p>  <p>CONNECTOR</p>
<p>5 x 2 pcs</p>  <p>ALLEN KEY</p>			

CARTON CONTENT:

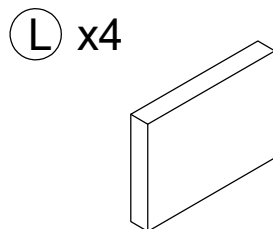
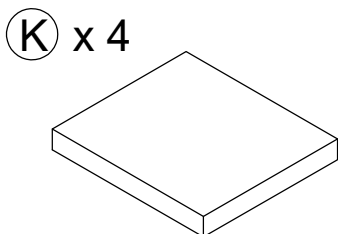
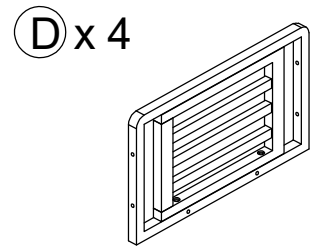
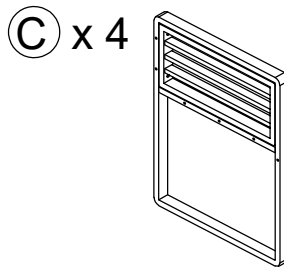
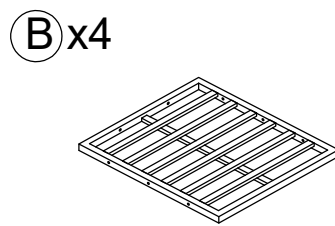
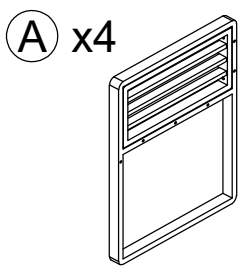
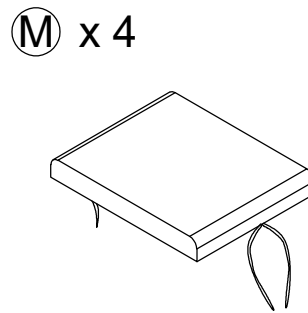
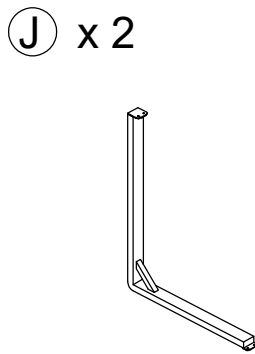
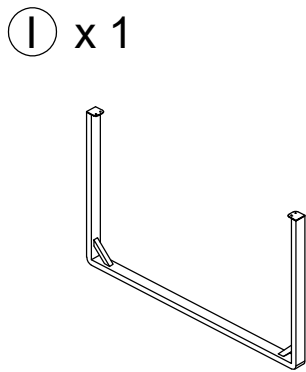
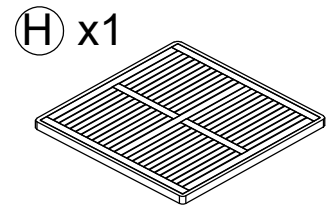
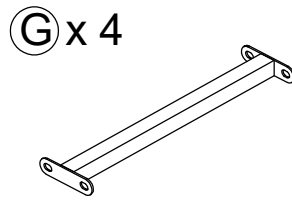
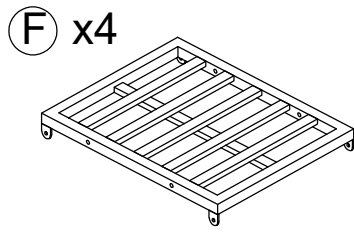
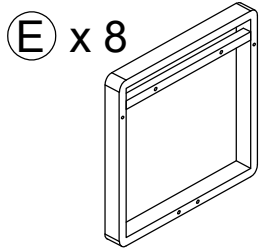

STEP 1

- | | |
|----------|-----------|
| B | x1 |
| D | x1 |
| 2 | x2 |
| 3 | x2 |

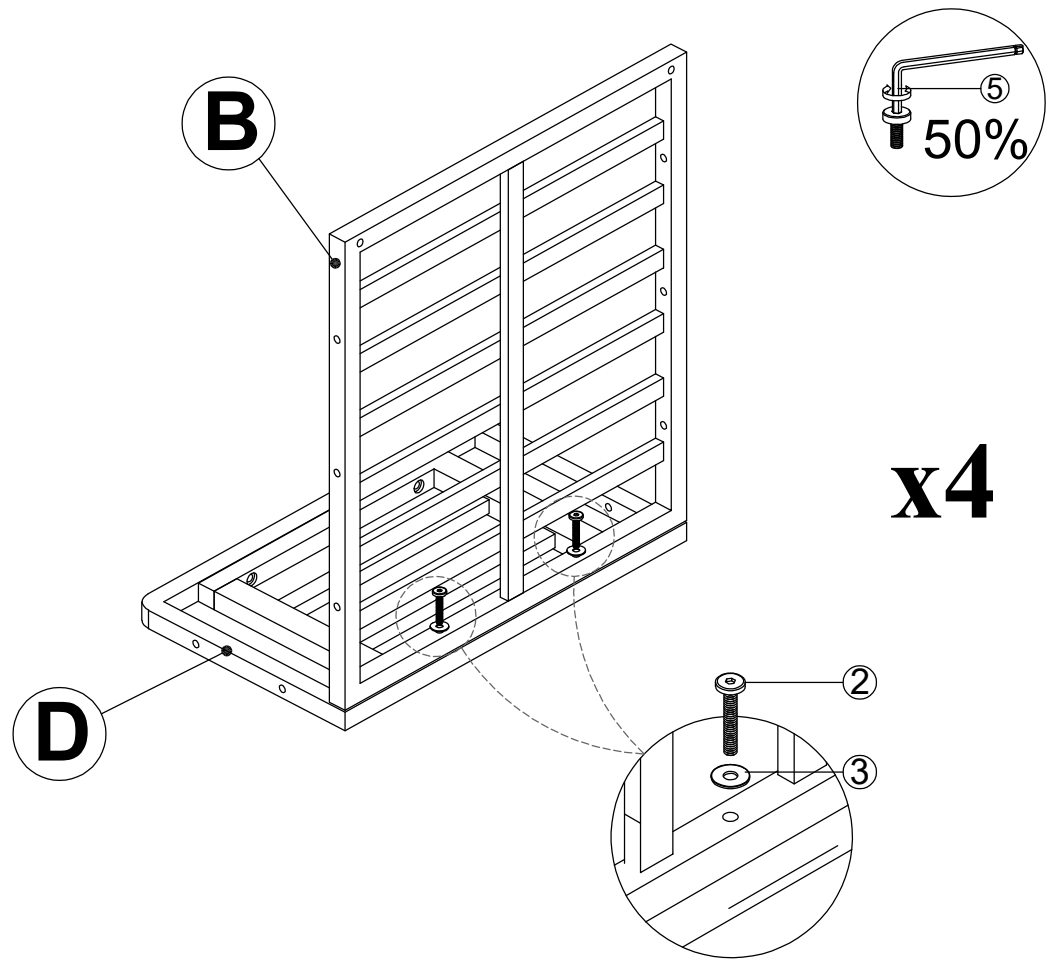

Connect Seat Chair (B) & Back Chair (D), Tighten Bolt (2) & Flat Washer (3) with Allen Key (5).

STEP 2

- | | |
|----------|-----------|
| A | x1 |
| 2 | x3 |
| 3 | x3 |

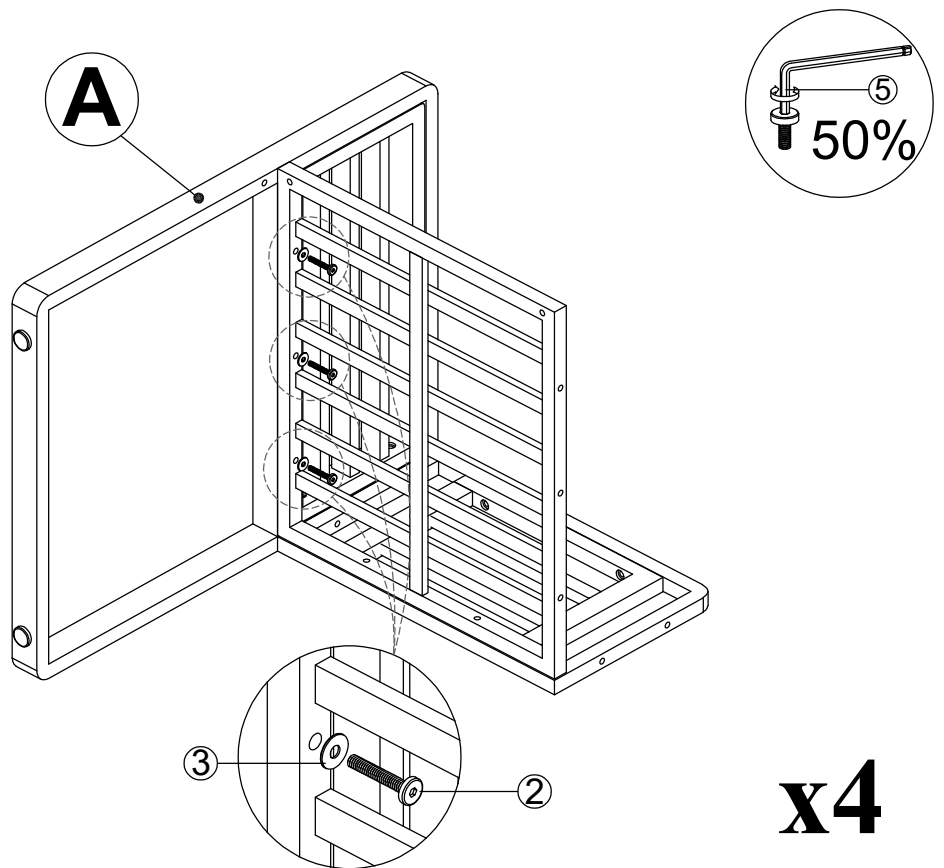

Connect the part from step 1 & Right Leg (A), Tighten Bolt (2) & Flat Washer (3) with Allen Key (5).

STEP 3

C	x1
---	----

2	x3
---	----

3	x3
---	----

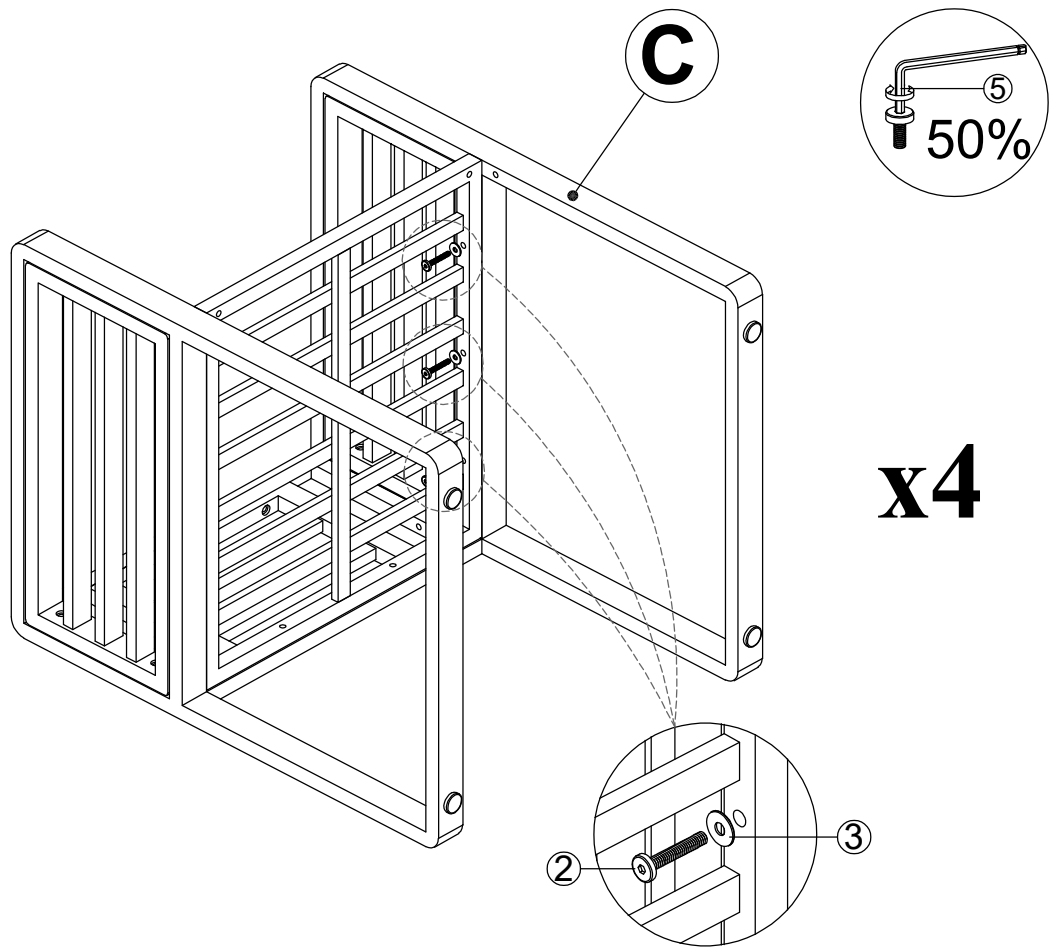

Connect the part from step 2 & Left Leg (C), Tighten Bolt (2) & Flat Washer (3) with Allen Key (5).

STEP 4

1	x4
---	----

3	x4
---	----

4	x2
---	----

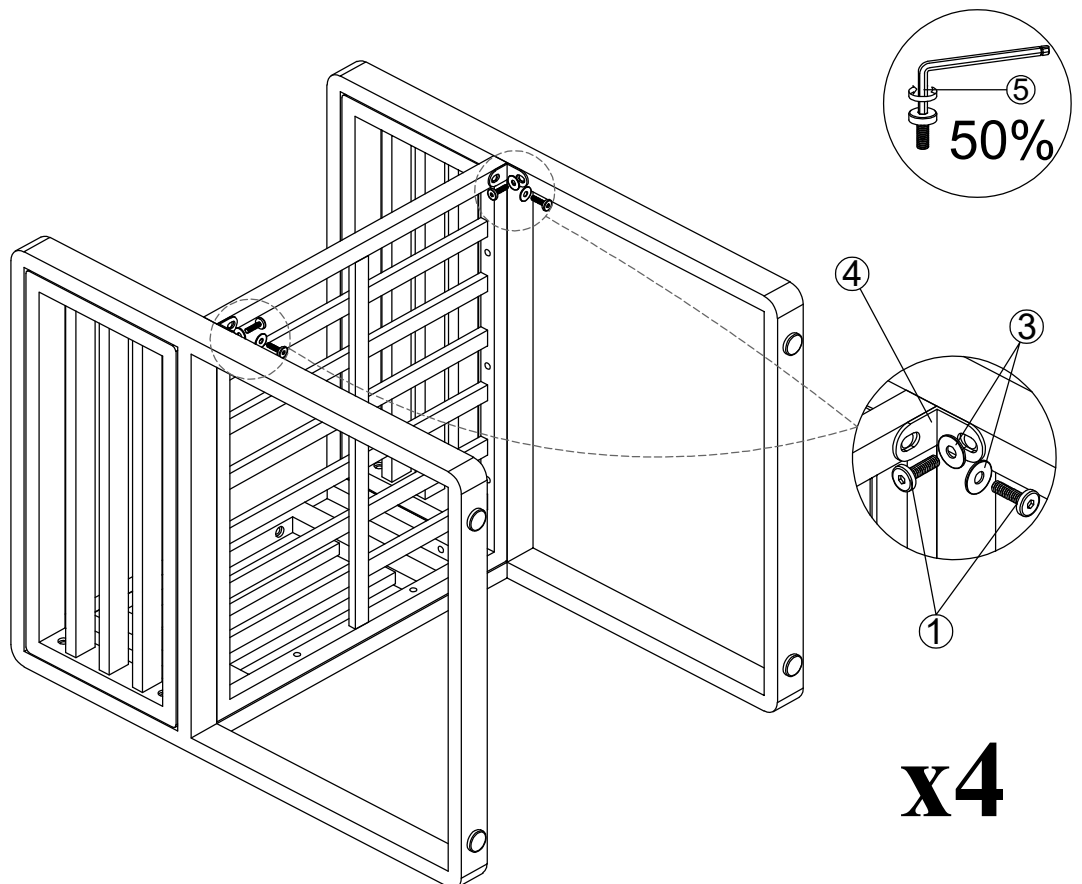

Connect the part from step 3 & Connector (4), Tighten Bolt (1) & Flat Washer (3) with Allen Key (5).

STEP 5

2	x4
3	x4

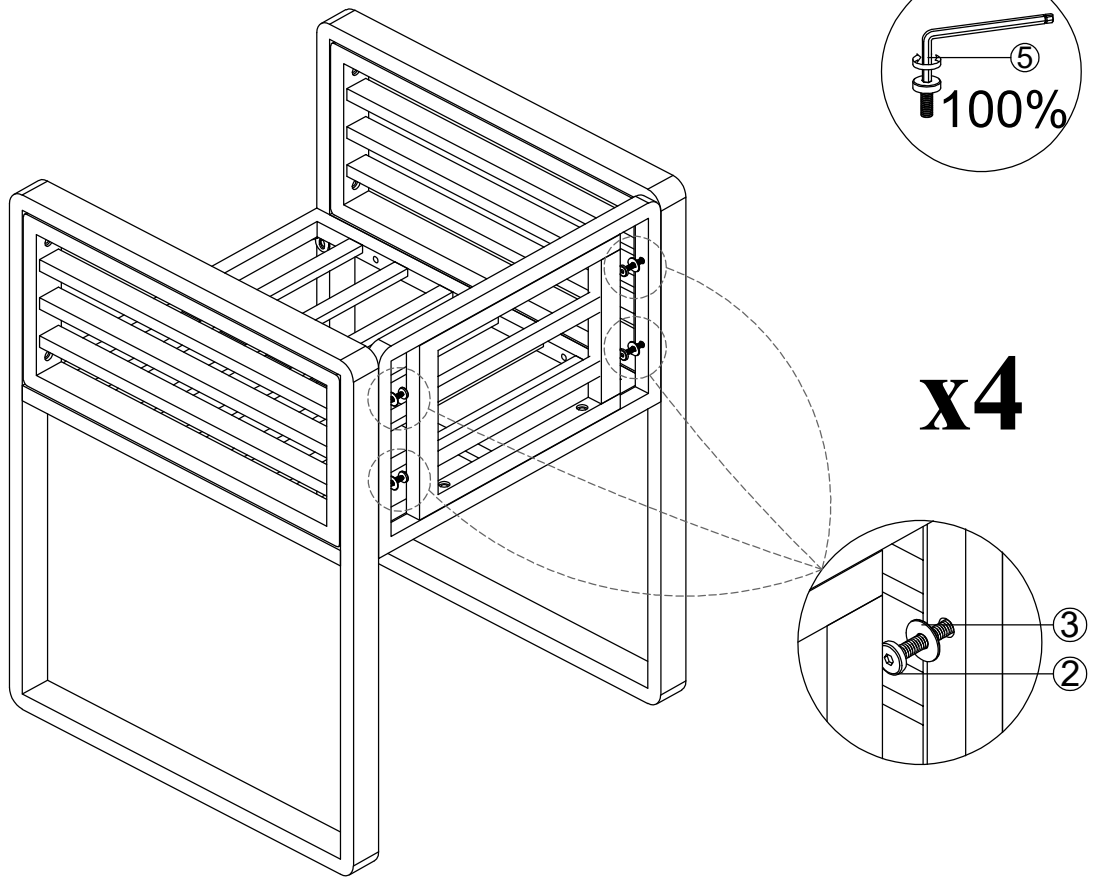

Connect the part from step 4 & Tighten Bolt (2) & Flat Washer (3) with Allen Key (5).

STEP 6

L	x1
K	x1

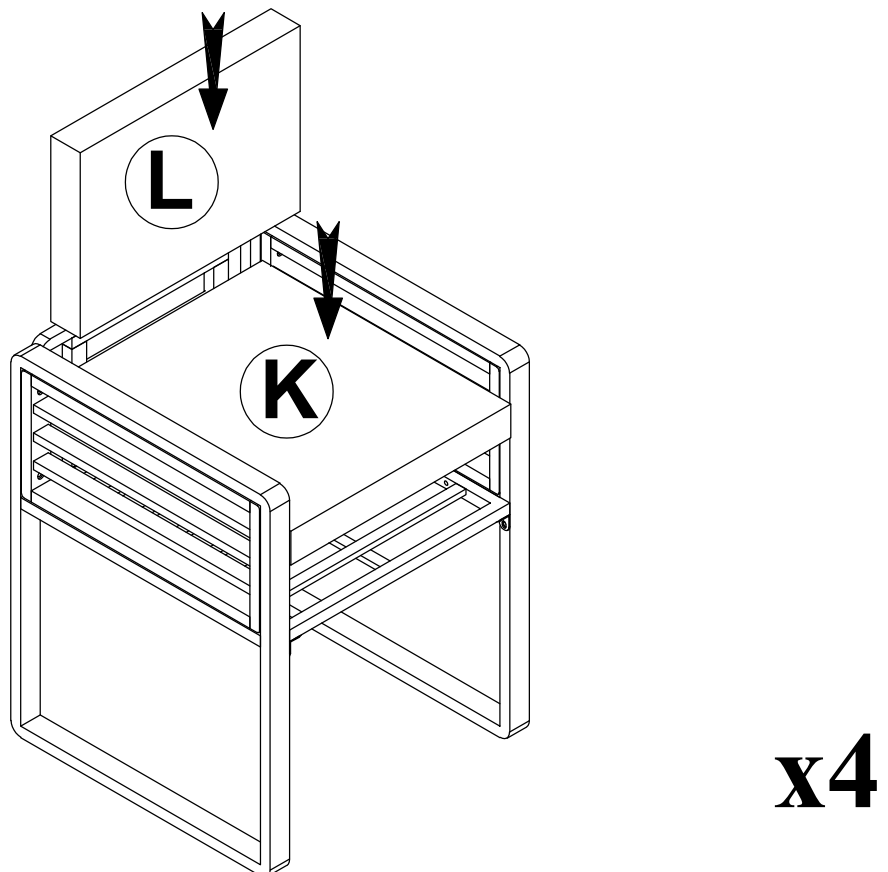

Open all the bags, adjust the cushions & Set up the seat Cushions (K) + Back Cushion (L).

STEP 7

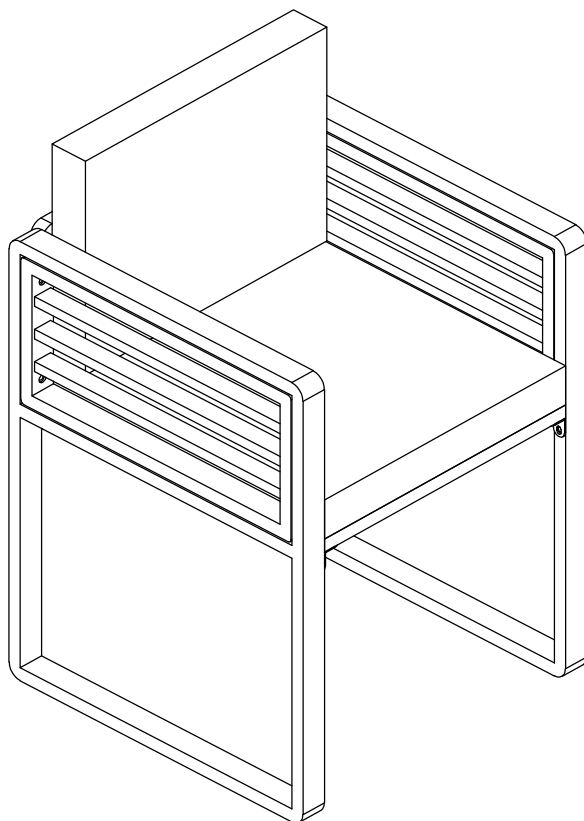

x4

Finish Chair.

STEP 8

E x1

F x1

2 x2

3 x2

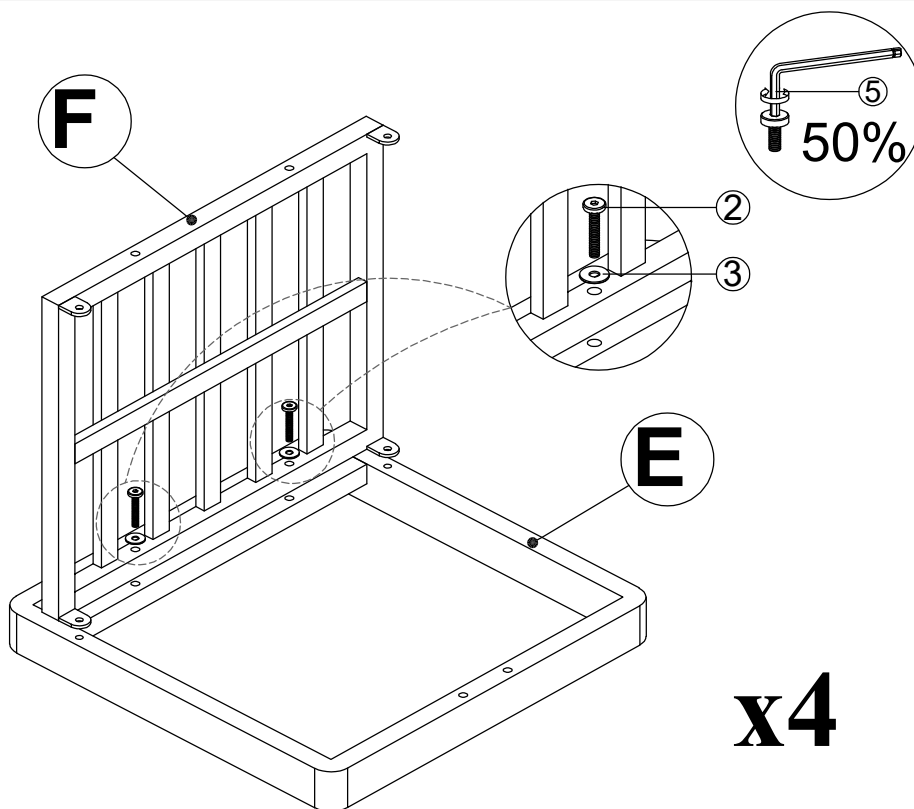

x4

Connect Leg Stool (E) & Seat Stool Frame (F), Tighten Bolt (2) & Flat Washer (3) with Allen Key (5).

STEP 9

- ① x2
- ③ x2

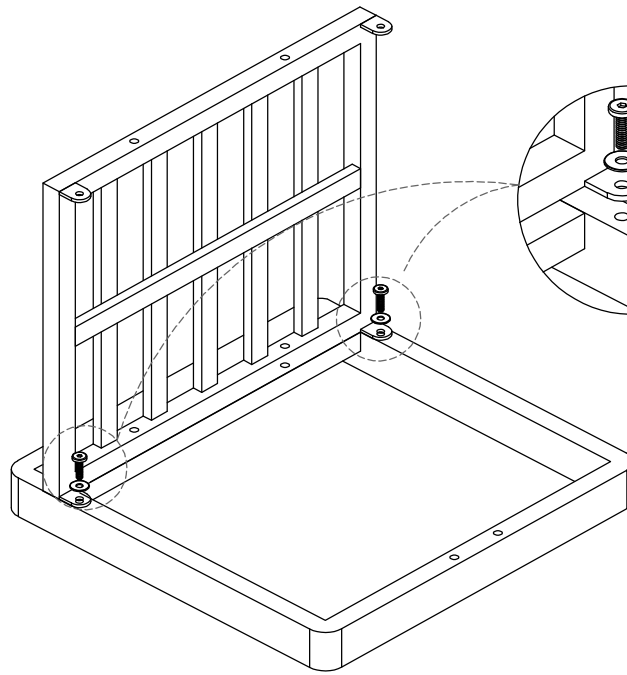

x4

Connect the part from step 8 & Tighten Bolt (1) & Flat Washer (3) with Allen Key (5).

STEP 10

- ② x2
- ③ x2

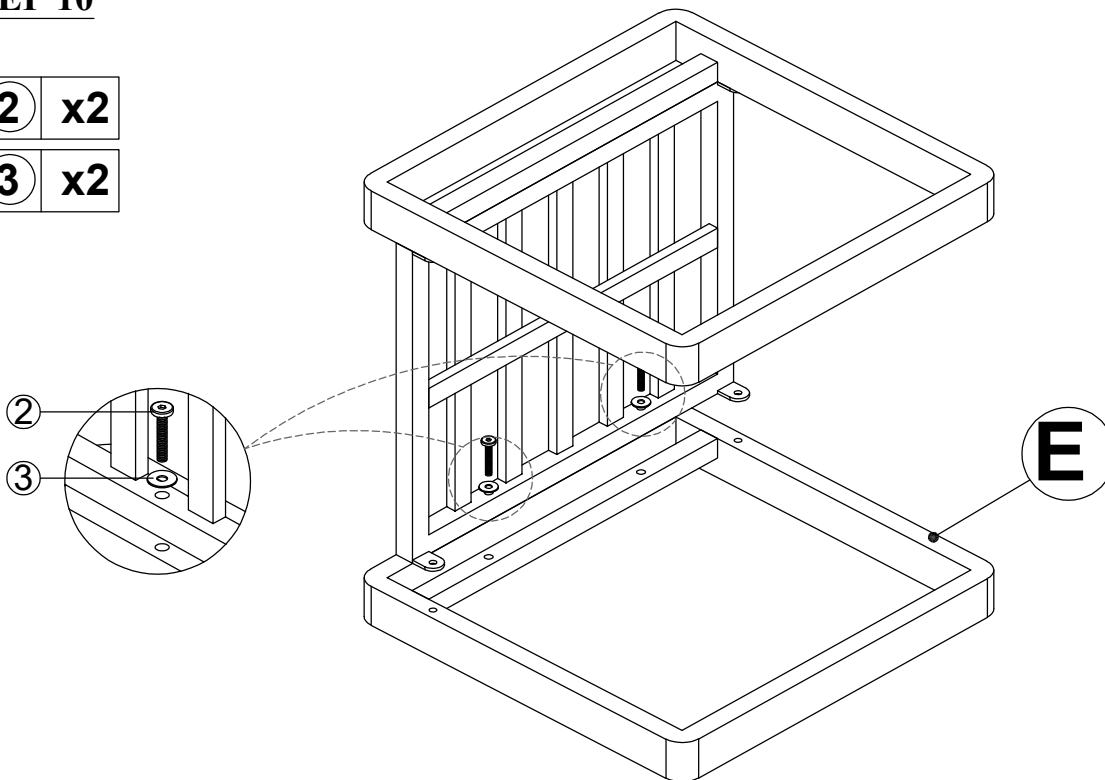
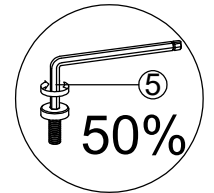

x4

Connect the part from step 9 & Leg Stool (E) & Tighten Bolt (2) & Flat Washer (3) with Allen Key (5).

STEP 11

① x2

③ x2

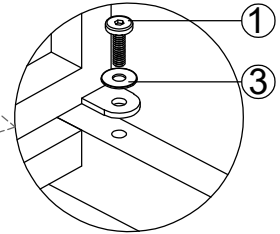
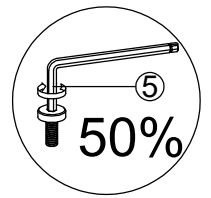
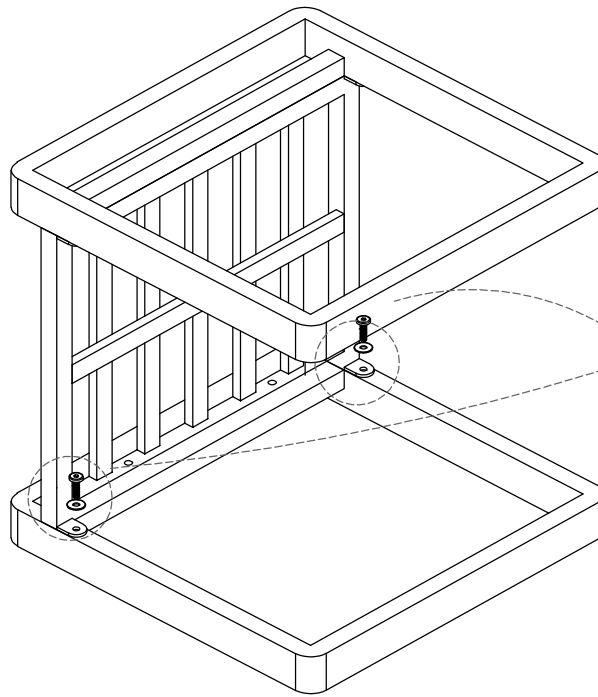

x4

Connect the part from step 10 & Tighten Bolt (1) & Flat Washer (3) with Allen Key (5).

STEP 12

G x1

① x4

③ x4

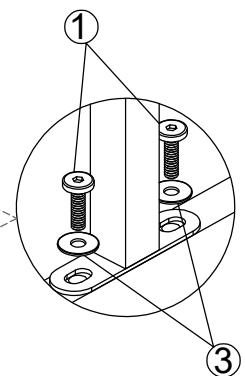
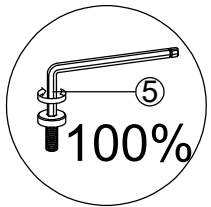
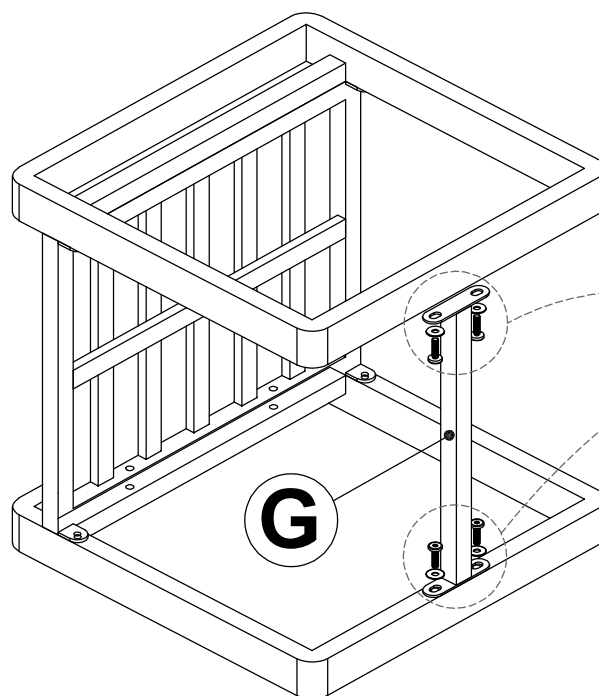

x4

Connect the part from step 11 & Support stool (G) Tighten Bolt (1) & Flat Washer (3) with Allen Key (5).

STEP 13

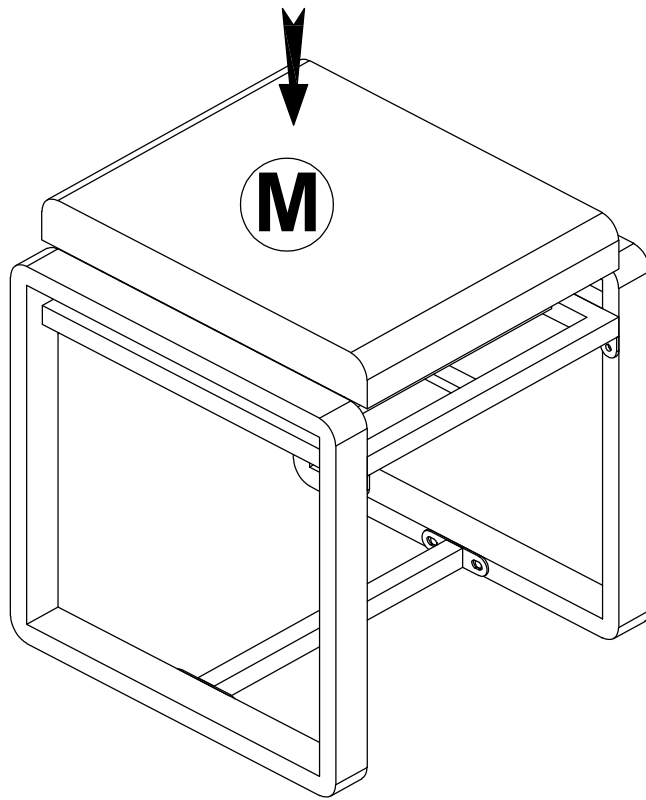

x4

Open all the bags, adjust the cushions, Set up the Seat Stool Cushion (M).

STEP 14

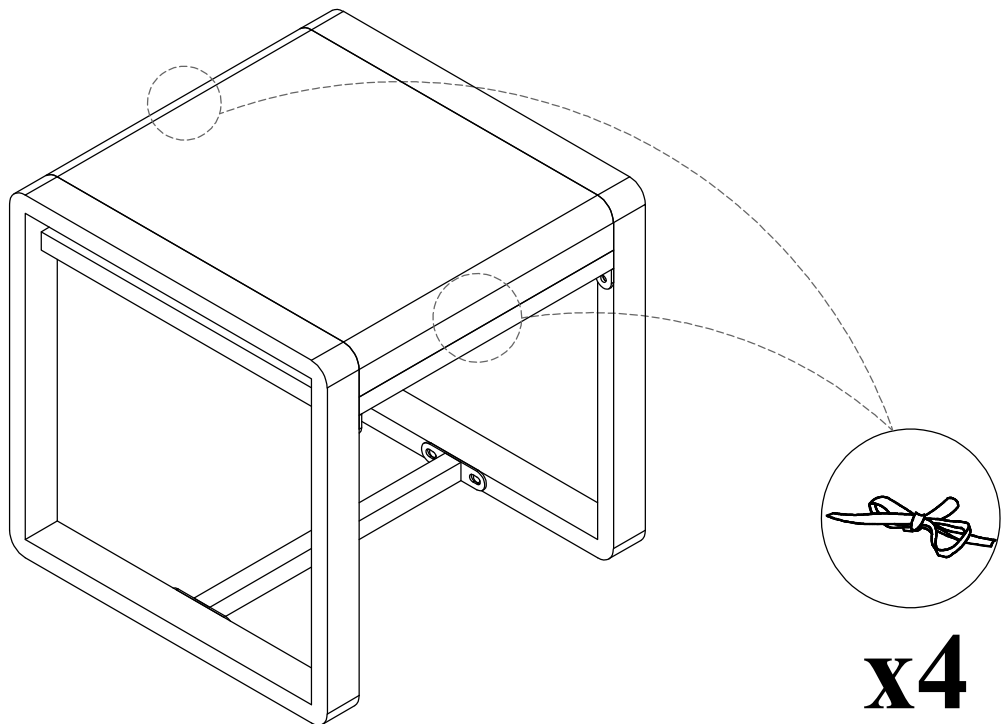

x4

Finish Stool.

STEP 15

I	x1
H	x1
1	x4
3	x4

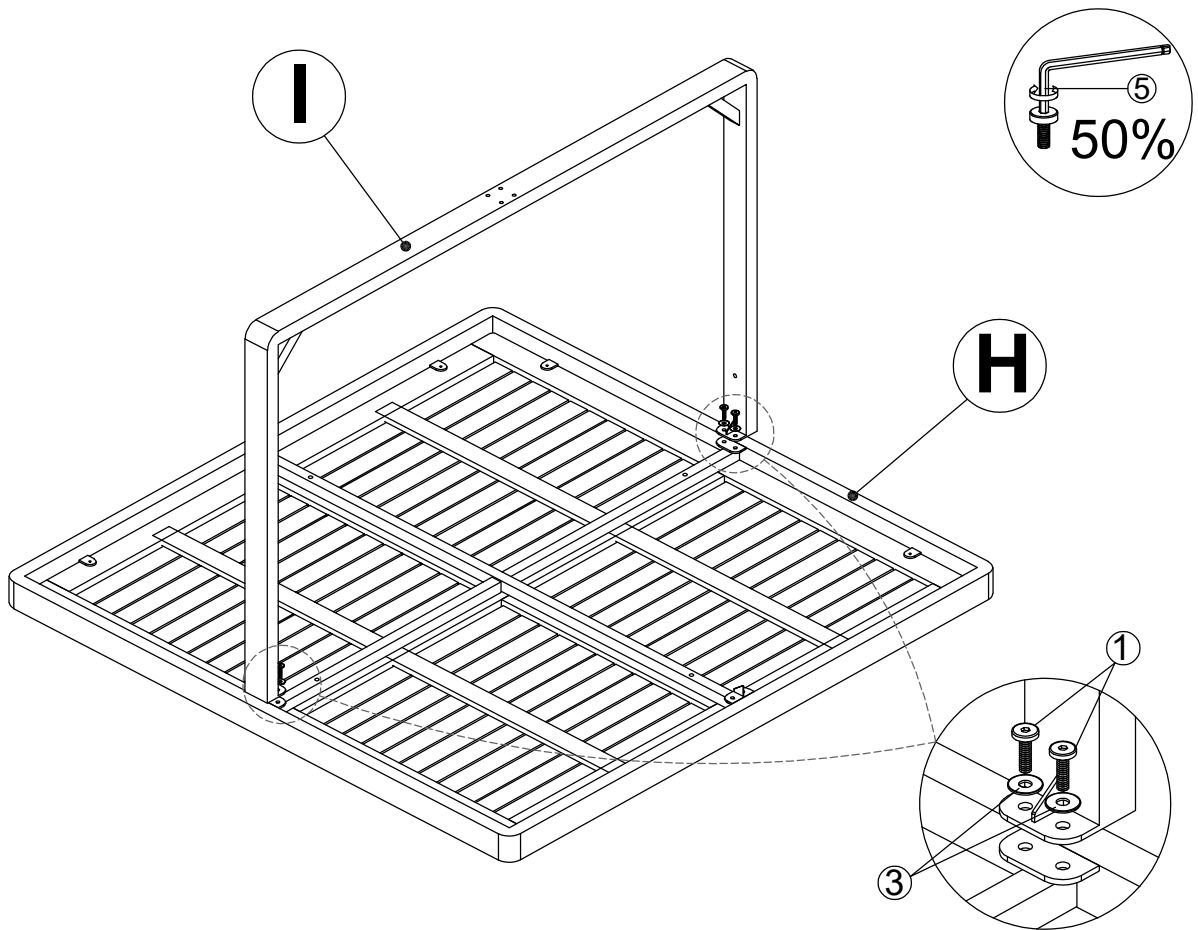

Connect Top Table (H) & Table Leg Middle (I), tighten Bolt (1) & flat washer (3) with Allen Key (5).

STEP 16

J	x2
1	x8
3	x8

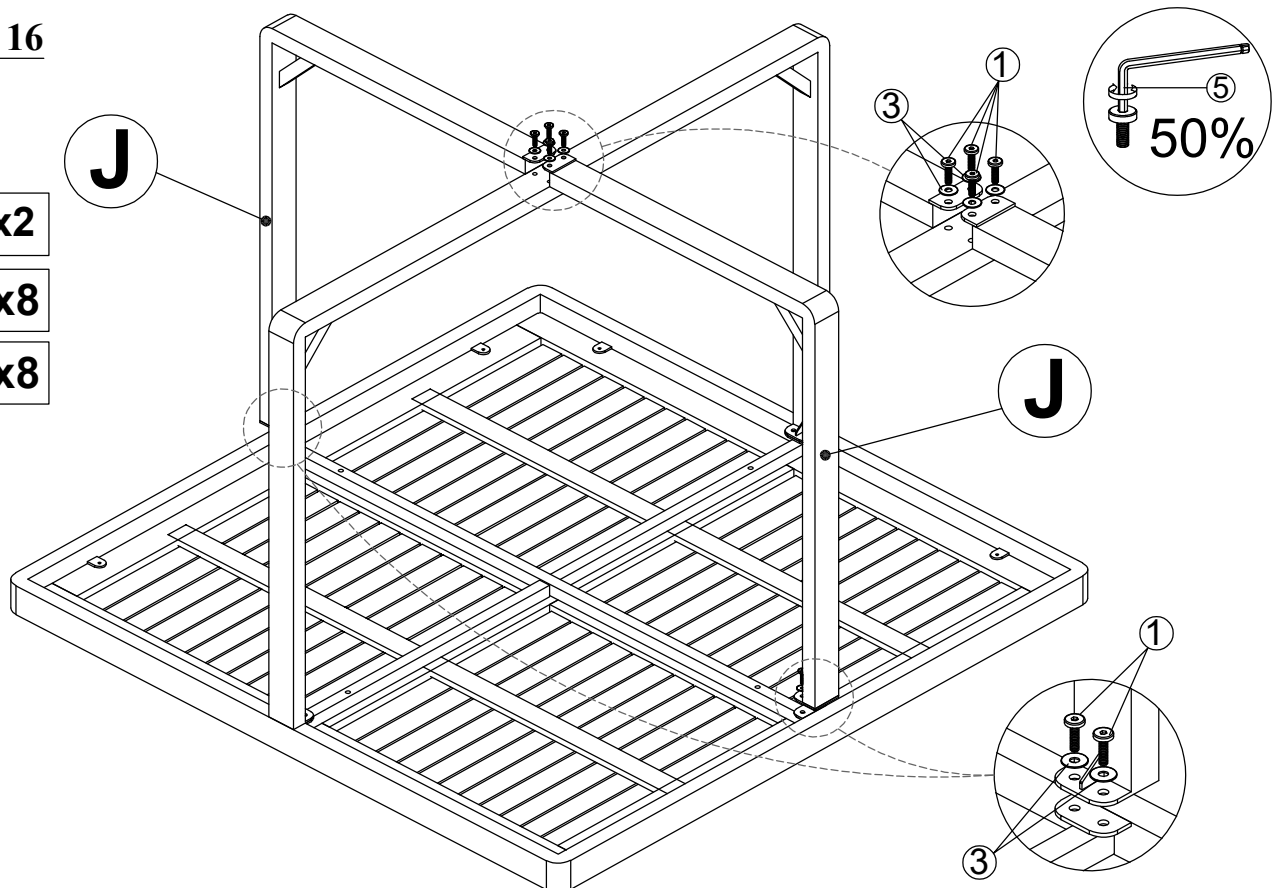

Connect the part from step 15 & Table Leg Left (J) tighten Bolt (1) & flat washer (3) with Allen Key (5).

STEP 17

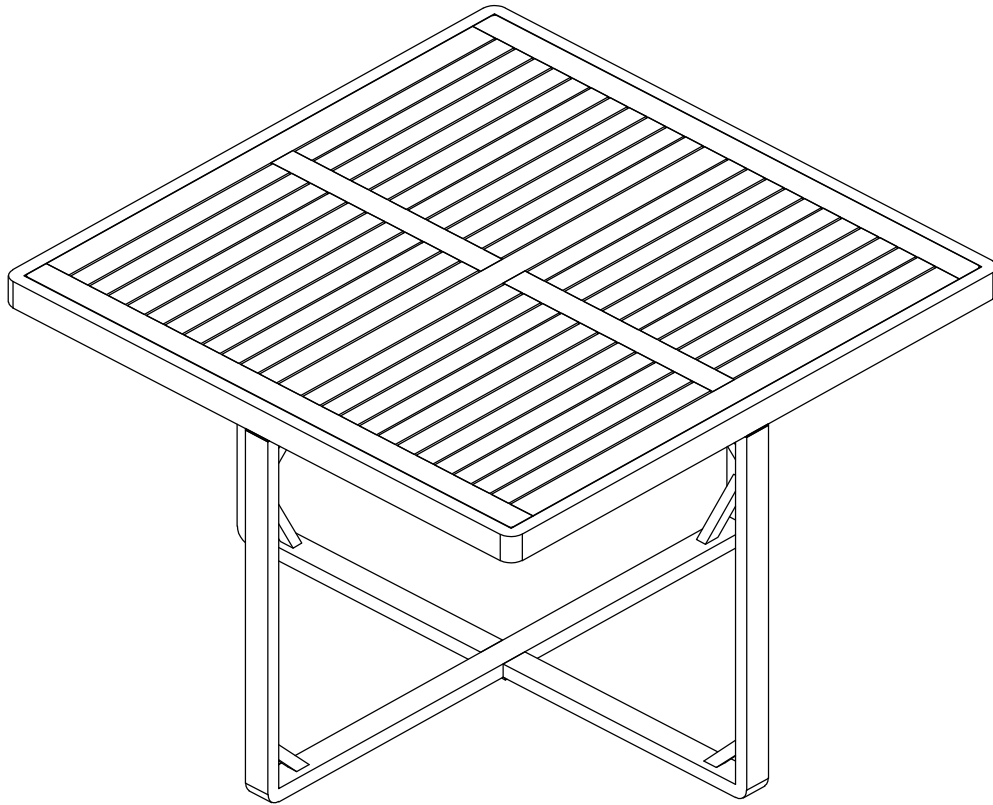
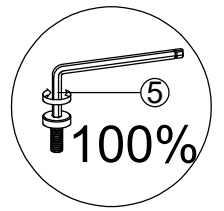

Finish Table.

STEP 18

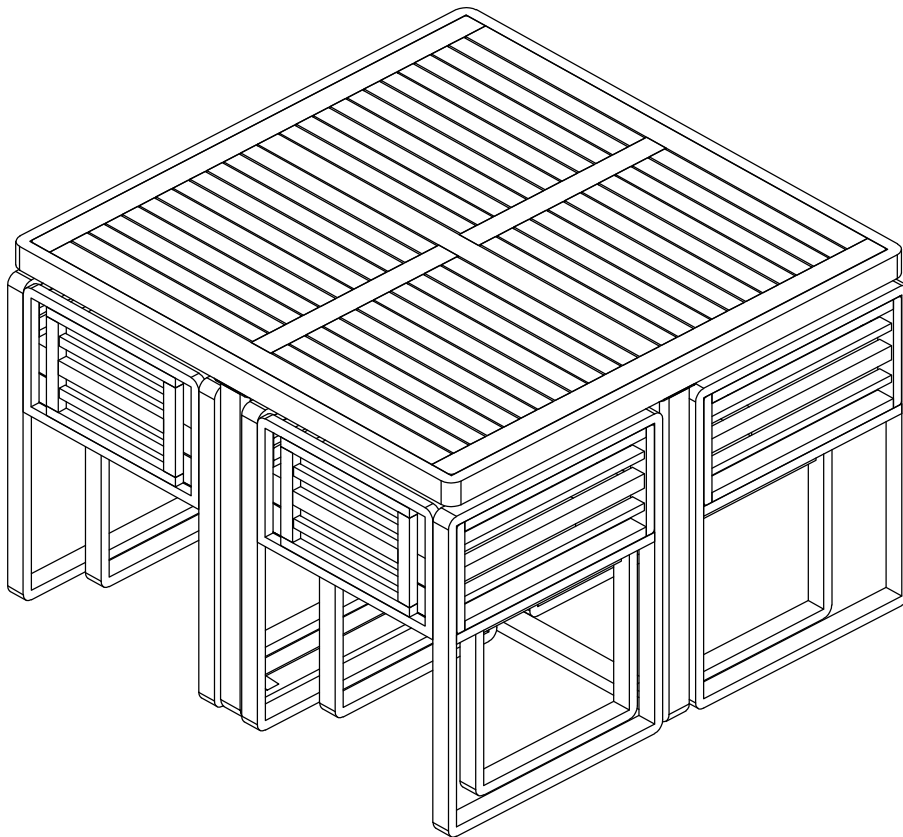

Finish.