

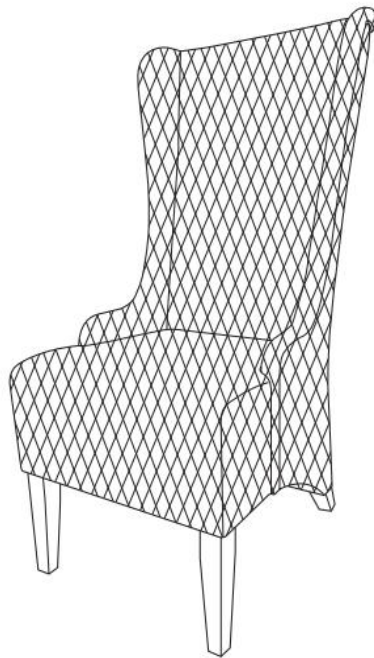

# Assembly Instructions

Caution: You must read this before you proceed.

## Wingback Chair

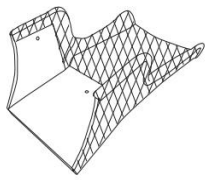
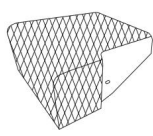

### Parts List

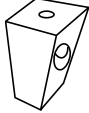
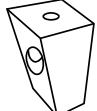
Label	Picture	Description	QTY
A		Chair Back	1
B		Seat	1
C		Front Leg	2
D		Left Back Leg	1
E		Right Back Leg	1

# Hardware

Label	Picture	Description	QTY
①		Bolt (M8X60)	3
②		Bolt (M8X35)	7
③		Washer M8*2.1MM	10
④		Washer M8*1.6MM	3
⑤		Spring Washer	13
⑥		Allen Wrench	1
⑦		Screw Arbor	4
⑧		Spanner	1
⑨		Nut	4

# Assembly Preparation

Before Beginning Assembly :

- X3
- X7
- X4
- X4
- X10
- X3
- X13



- Read instructions, cover to cover-



- Have 2 adults on hand for assembly-



- Do not assemble on flooring or carpet-



- Assemble on a clean non-marring surface (packing foam)-



- Save all packaging until finished-

## Assembly Steps

### OVERVIEW

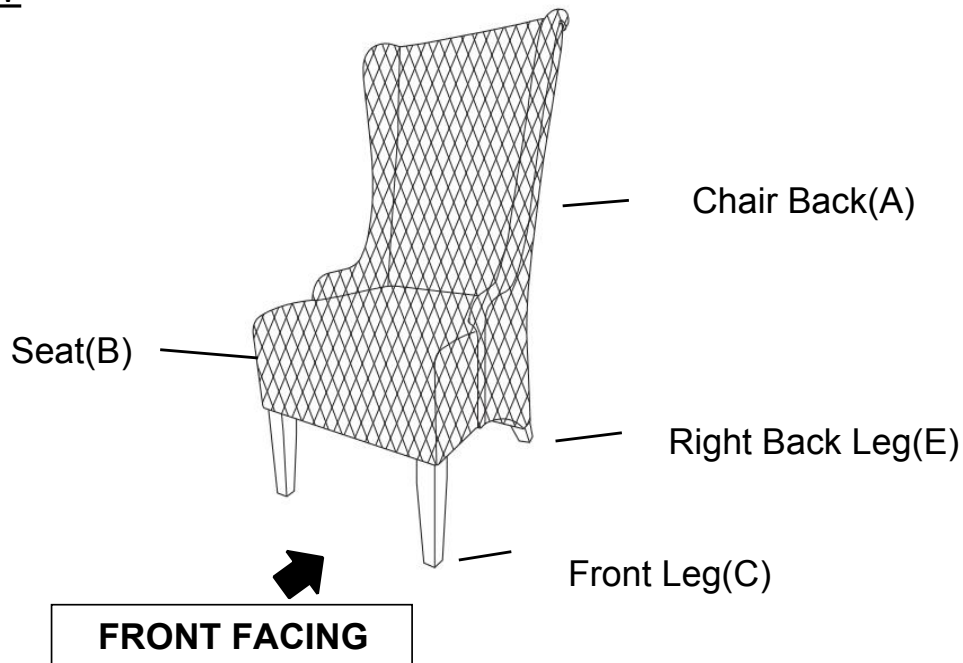

This Wingback Chair has multiple parts and may require up to 30 minutes to assemble. To give you an overview of the Chair parts, the above picture is to help you put the various parts into perspective. Please read through the instructions below to familiarise yourself with the parts and steps before assembly.

### Step 1

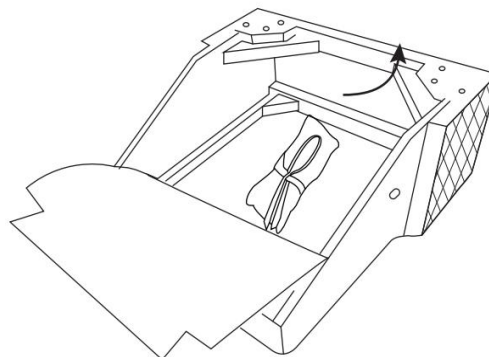

Carefully remove the Seat Base Cover from the Seat(B).  
Take out the Legs and Hardware.

## Step 2

### Step 2.1

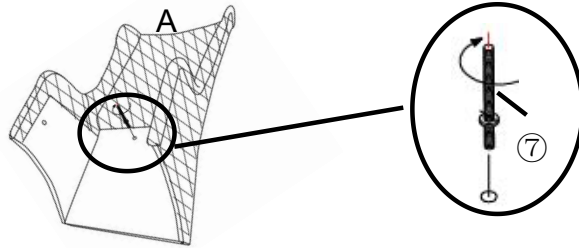

### Step 2.2

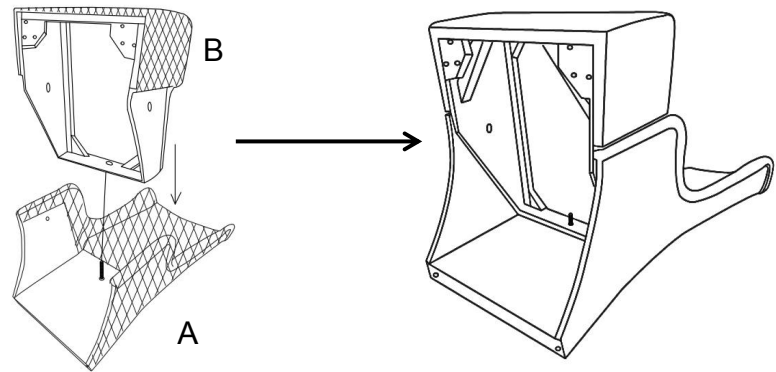

Step 2.1 Screw the Screw Arbor(⑦) into Chair Back(A) by turning clockwise as shown.

Step 2.2 After Step 2.1, Push down the Seat(B) using a good amount of pressure to make the Seat(B) connect with Chairback(A) through the Screw Arbor(⑦) of Chair Back(A) as shown.

## Step 3

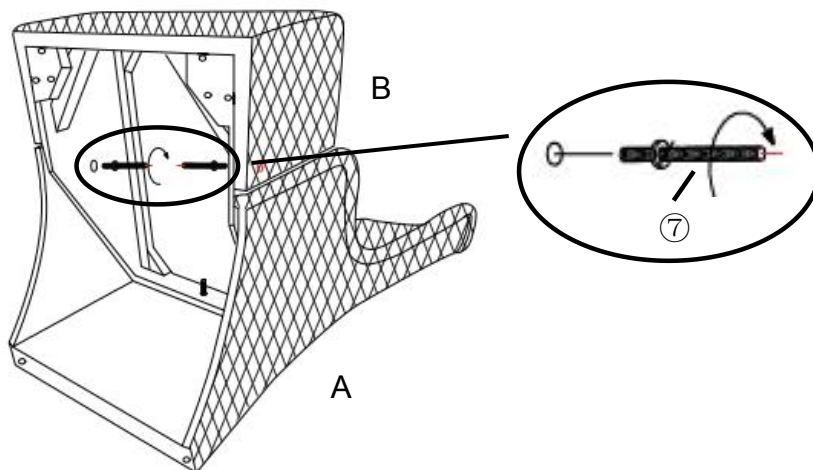

Connect Chair Back(A) with Seat(B) using Screw Arbor(⑦) and tightening tighten by turning the Screw Arbor(⑦) clockwise, as shown.

## Step 4

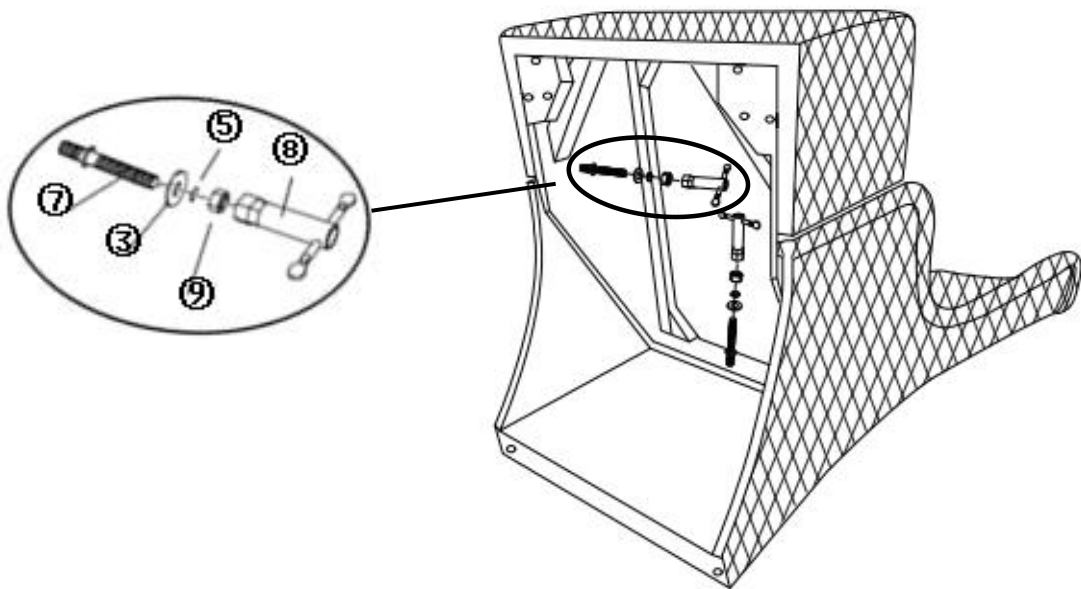

Align the mounting positions on the right ,middle and left of Chair Back(A) and Seat(B); using the Spring Washers(⑤) , Washers(③), Nut(⑨) mounted on Screw Arbor(⑦) with Spanner(⑧).

## Step 5

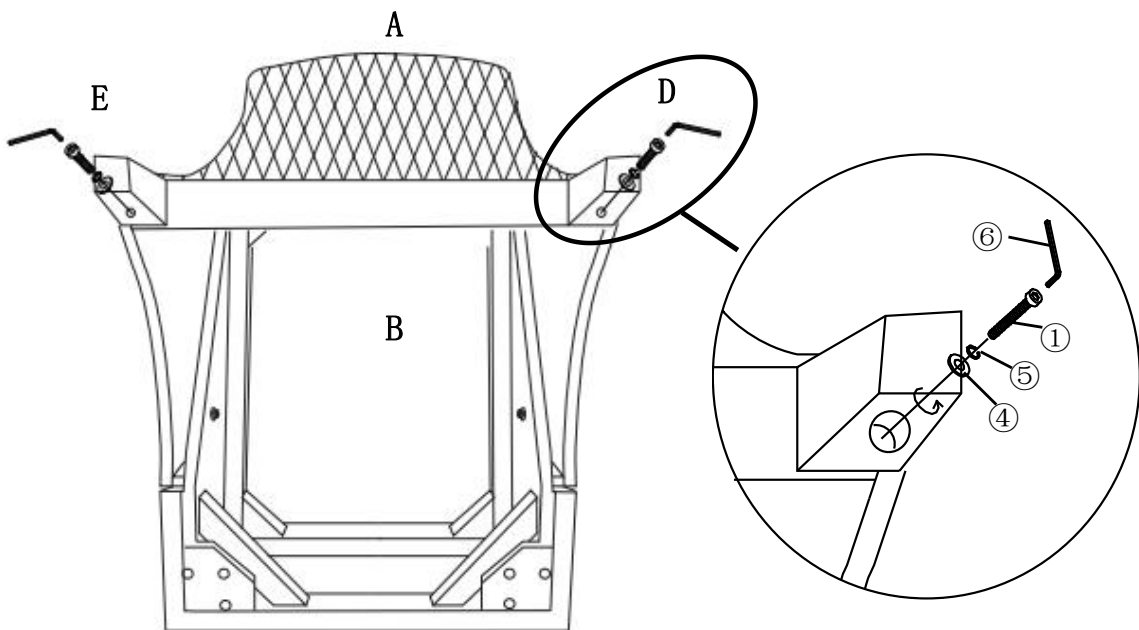

Attach Back Leg(D) to the bottom of the Chair Back(A) using Bolt(①), Spring Washer(⑤) and Washer(④) with Allen Key(⑥).

**Do not fully tighten the Bolts.**

Repeat the same process with Back Leg(E).

## Step 6

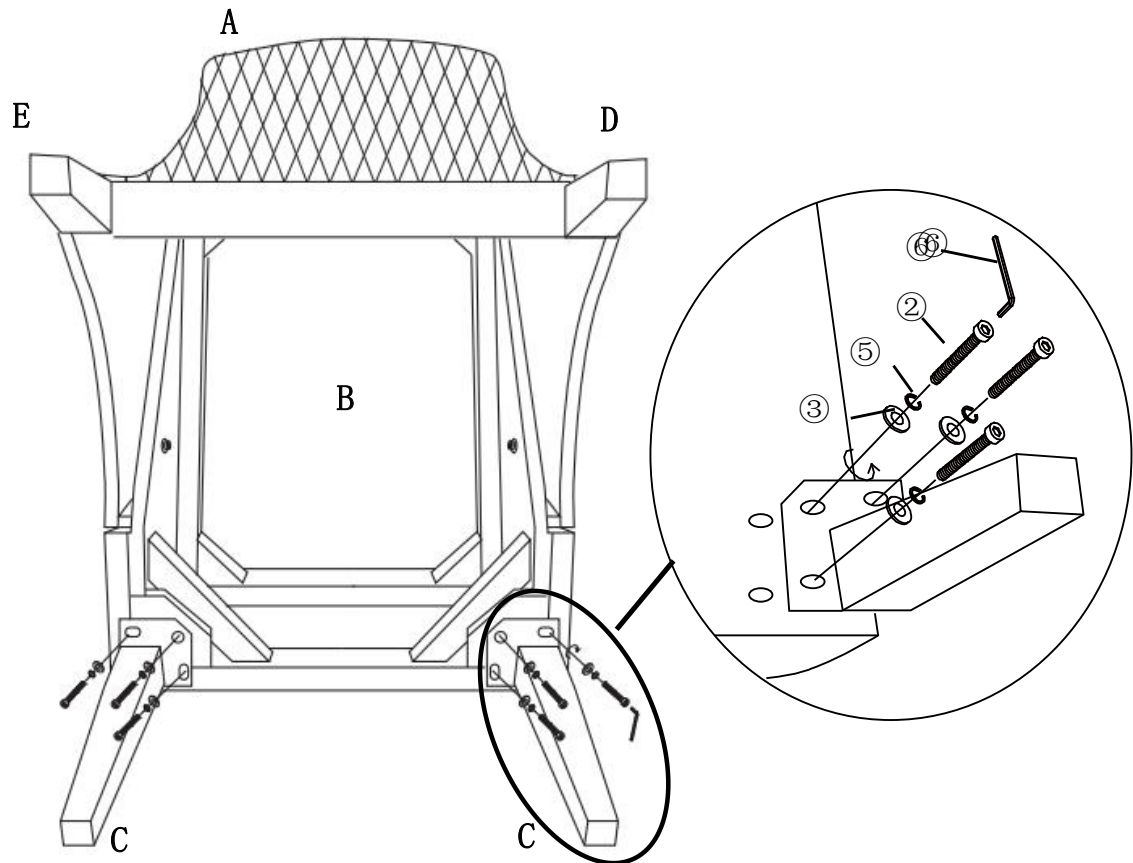

Align the mounting positions of Front Legs(C) to Seat(B), then attach using Bolts(②), Spring Washers(⑤) and Washers(③) with Allen Key(⑥).

**Do not fully tighten the Bolts.**

## Step 7

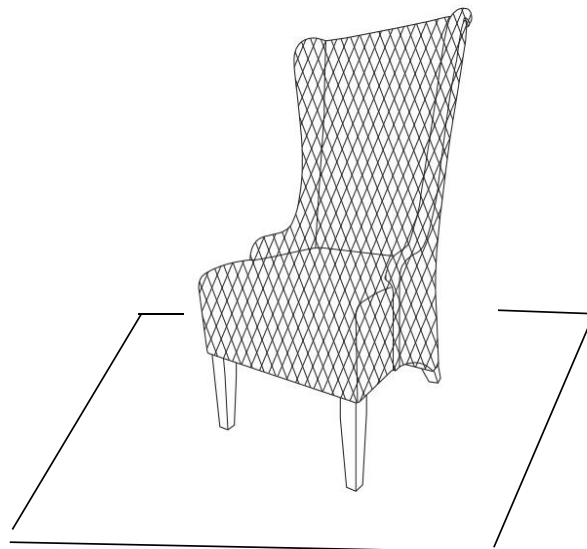

Stand the Chair up and place on flat, level surface.

Carefully and gently sit onto the Chair. This will help properly align all parts at all joints and remove any gaps.

Carefully get off the Chair and gently turn it over.

**Tighten all Bolts at all joints. When tightening the Bolts, tighten in a sequential manner**

Step 8

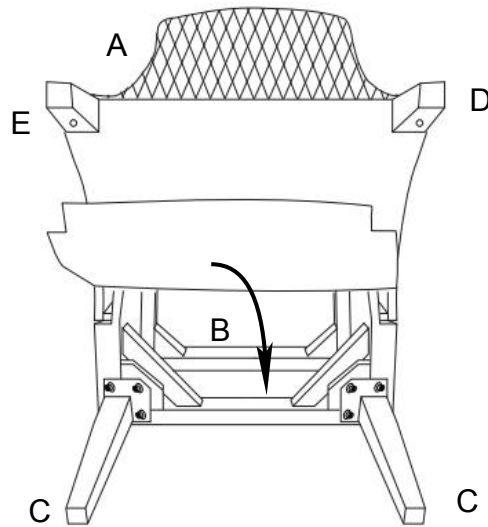

Smooth down the Seat Base Cover your hand along the Magic Tape on all four sides at the edge of the Seat.  
Make sure all parts are connected and securely locked into position.

Step 9

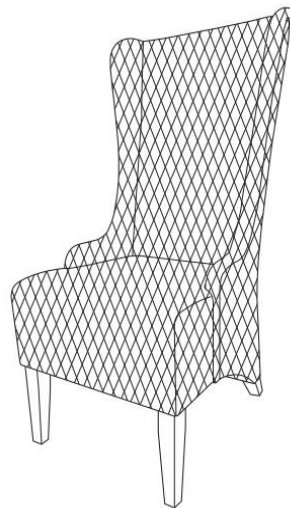

Your Wingback Chair is ready for use.  
**This Wingback Chair can only be used on a flat, level surface.**