

Assembly Instructions

Please check that you have all the parts listed before you start assembling, if you do find that something is missing, do not continue assembly, please contact us immediately.

NOTE: Please do not completely tighten all the hardware until the entire assembly is complete!

Bauanleitung

Bitte überprüfen Sie, ob alle Teile mitgeliefert sind, bevor Sie mit der Montage beginnen. Wenn Sie festlegen, dass etwas fehlt, setzen Sie die Montage nicht fort, Bitte kontaktieren Sie uns sofort.

Achtung: Bitte ziehen Sie nicht alle Schrauben fest, bevor die Montage abgeschlossen ist!

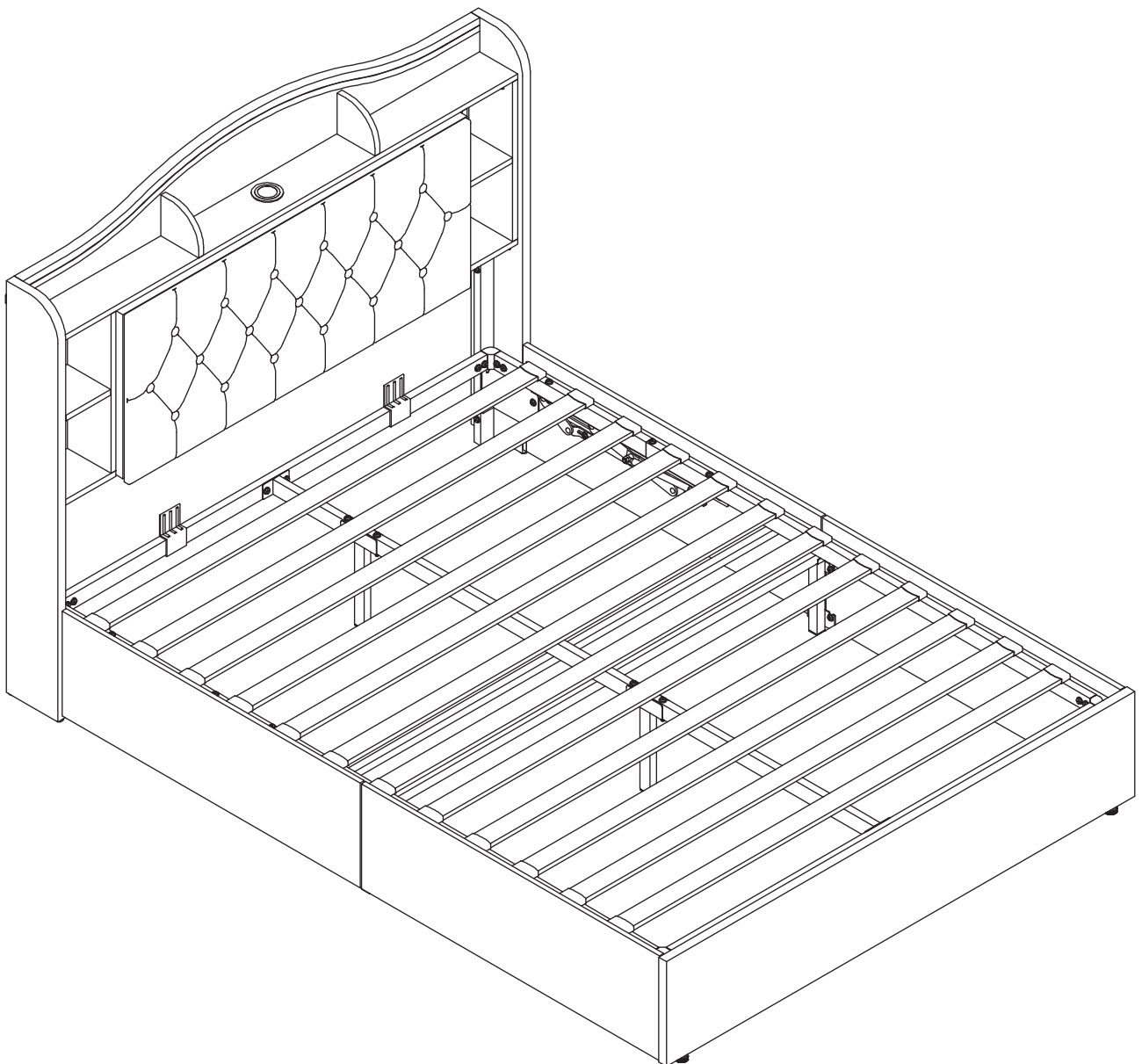

Stückliste

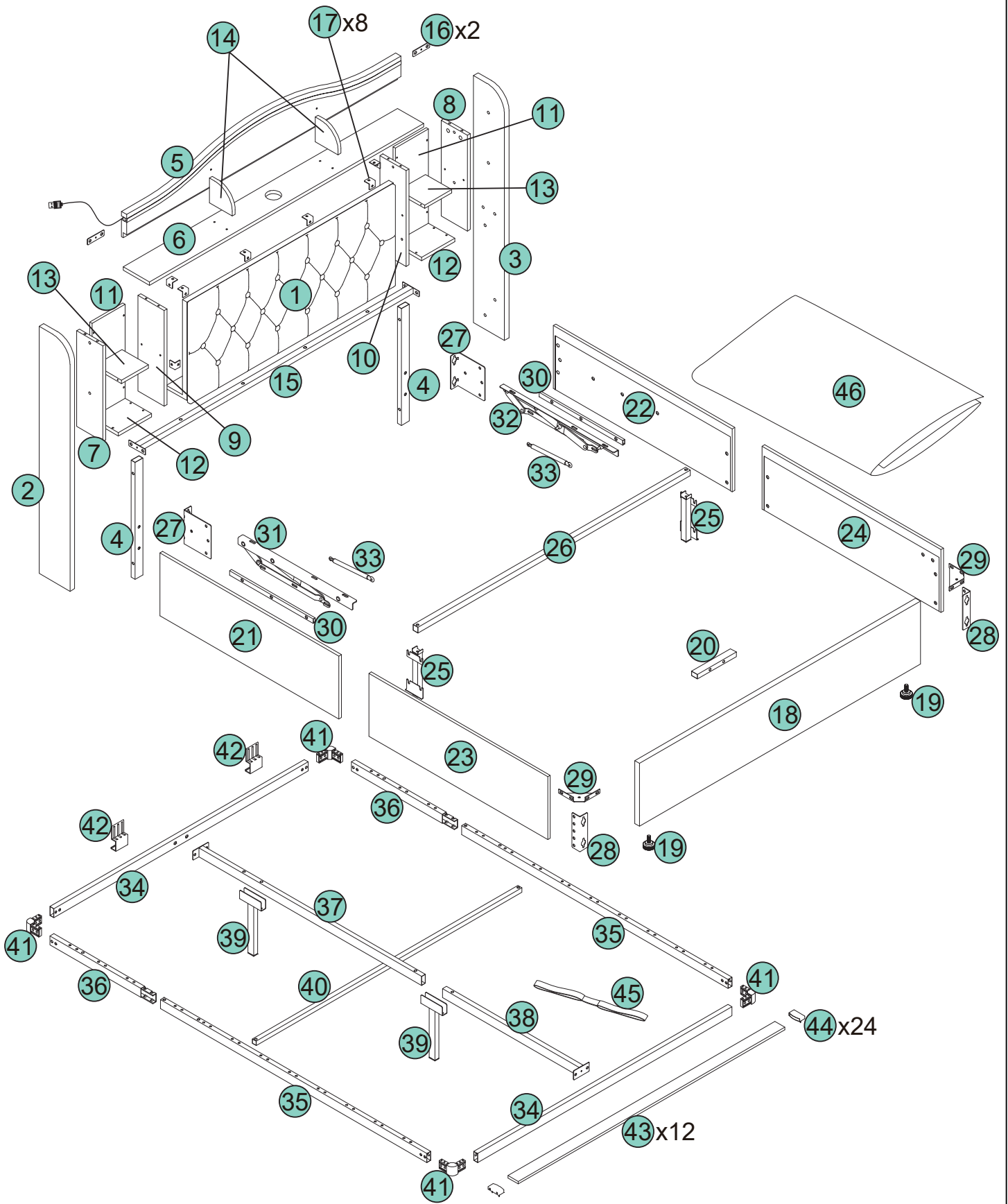



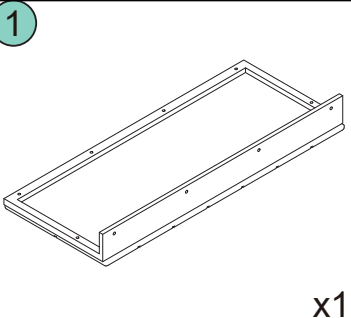
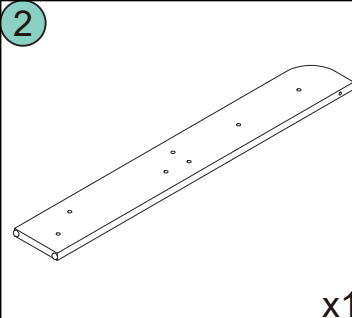
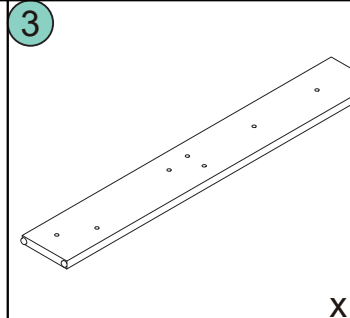
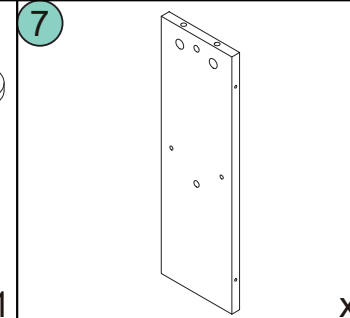
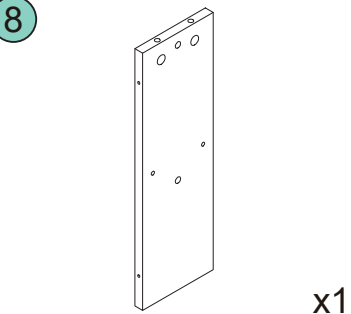
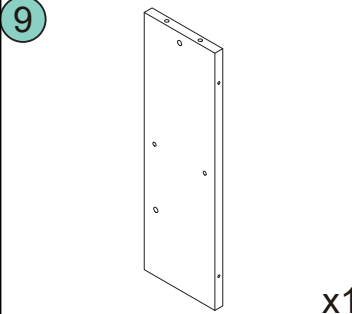
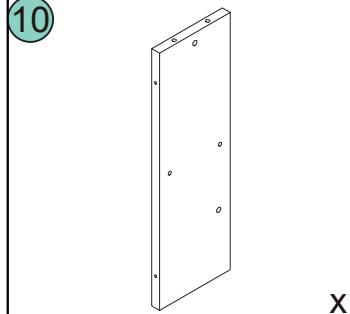
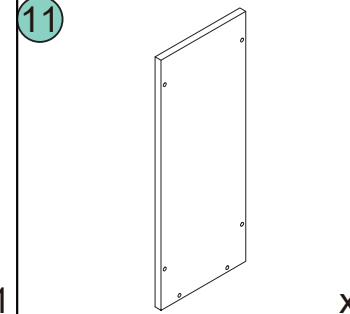
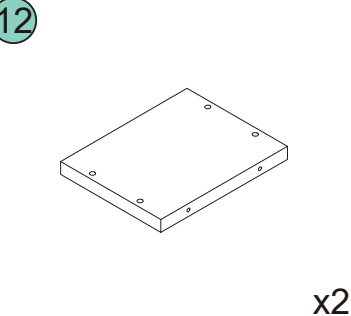
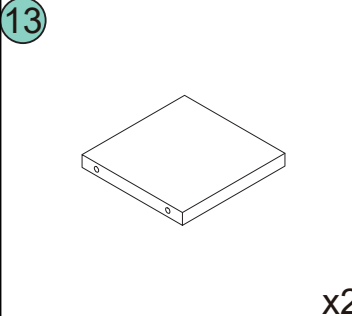
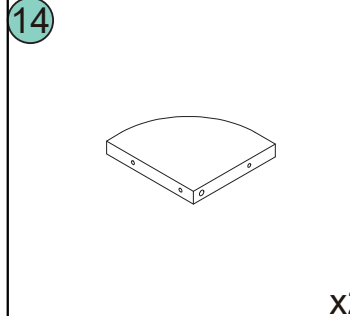
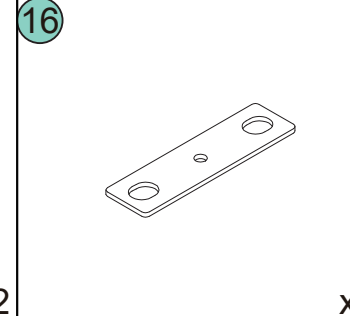
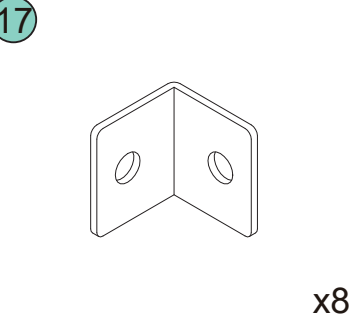
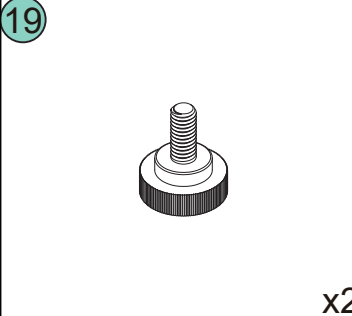
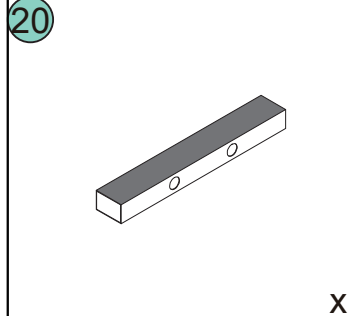
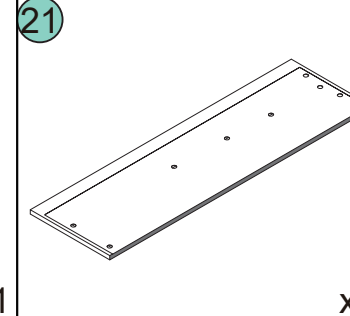
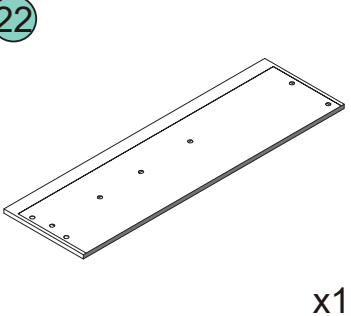
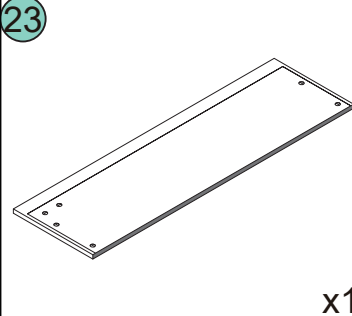
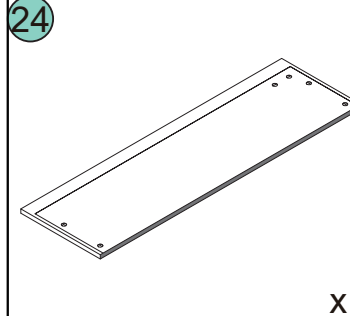
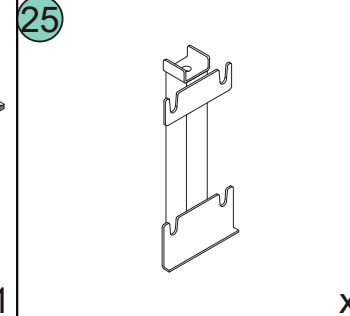
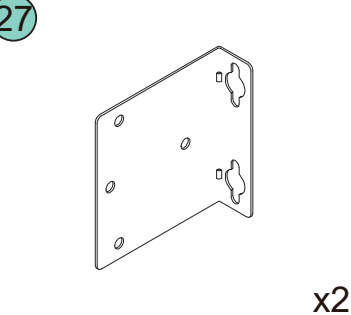
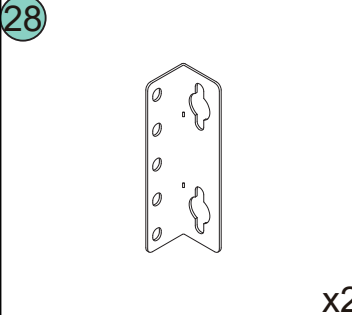
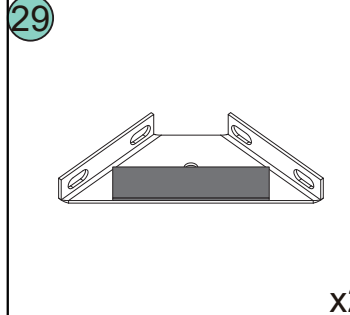
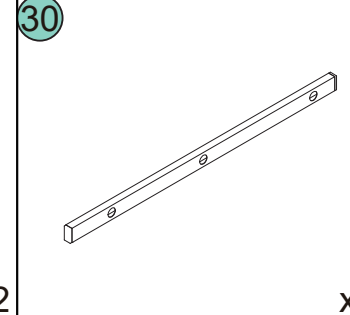



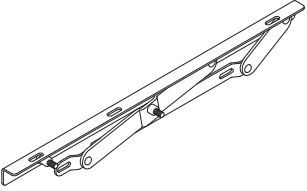
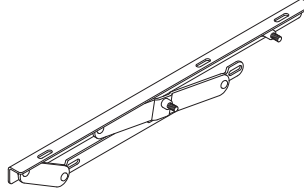
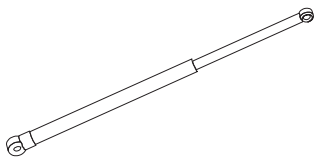
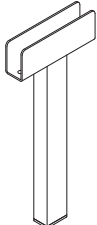
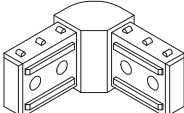
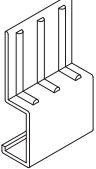
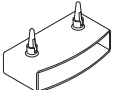
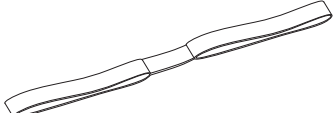
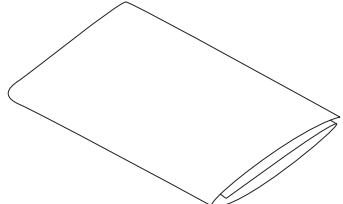
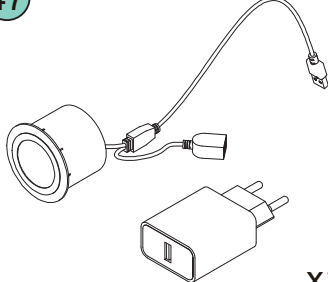
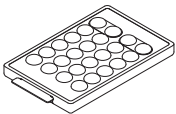
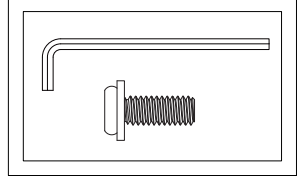

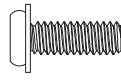
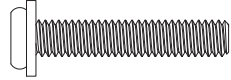
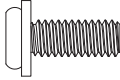
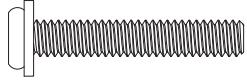
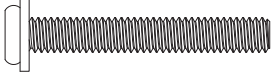

BOX-1/2

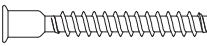
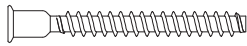
 <p>1</p> <p>x1</p>	 <p>2</p> <p>x1</p>	 <p>3</p> <p>x1</p>	 <p>7</p> <p>x1</p>
 <p>8</p> <p>x1</p>	 <p>9</p> <p>x1</p>	 <p>10</p> <p>x1</p>	 <p>11</p> <p>x2</p>
 <p>12</p> <p>x2</p>	 <p>13</p> <p>x2</p>	 <p>14</p> <p>x2</p>	 <p>16</p> <p>x2</p>
 <p>17</p> <p>x8</p>	 <p>19</p> <p>x2</p>	 <p>20</p> <p>x1</p>	 <p>21</p> <p>x2</p>
 <p>22</p> <p>x1</p>	 <p>23</p> <p>x1</p>	 <p>24</p> <p>x1</p>	 <p>25</p> <p>x2</p>
 <p>27</p> <p>x2</p>	 <p>28</p> <p>x2</p>	 <p>29</p> <p>x2</p>	 <p>30</p> <p>x2</p>

BOX-1/2

 <p>31</p> <p>x1</p>	 <p>32</p> <p>x1</p>	 <p>33</p> <p>750N</p> <p>x2</p>	 <p>39</p> <p>x2</p>
 <p>41</p> <p>x4</p>	 <p>42</p> <p>x2</p>	 <p>44</p> <p>x24</p>	 <p>45</p> <p>x1</p>
 <p>46</p> <p>x1</p>	 <p>47</p> <p>x1</p>	 <p>48</p> <p>x1</p>	 <p>hardware kit</p>

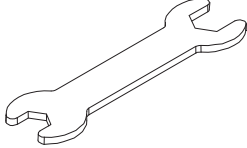
Hardware List- Hardware-Liste

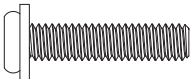
<p>(A) x10+2 PCS</p>  <p>1/4"x13mm</p>	<p>(B) x10+2 PCS</p>  <p>1/4"x19mm</p>	<p>(C) x4+1 PCS</p>  <p>5/16"x35mm(Silver)</p>	<p>(D) 60+4 PCS</p>  <p>5/16"x16mm</p>	<p>(E) x9+2 PCS</p>  <p>5/16"x40mm</p>
<p>(F) x16+2 PCS</p>  <p>5/16"x55mm</p>	<p>(G) x10+2 PCS</p>  <p>5/16"</p>	<p>(H) x32+2 PCS</p>  <p>M5x35mm</p>	<p>(J) x2+1 PCS</p>  <p>M5x50mm</p>	<p>(K) x4+1 PCS</p>  <p>Ø6x35mm</p>
<p>(L) x4+1 PCS</p>  <p>Ø15x10mm</p>	<p>(M) x10+2 PCS</p>  <p>Ø6x30mm</p>	<p>(N) x1 PC</p>  <p>4mm</p>	<p>(P) x1 PC</p>  <p>3mm</p>	<p>(Q) x1 PC</p> 
<p>(R) x1 PC</p>  <p>4mm</p>	<p>(S) x6+1 PCS</p>  <p>5/16"x30mm</p>			

BOX-2/2

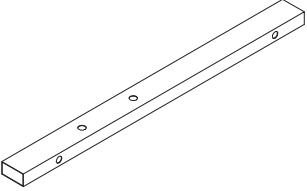
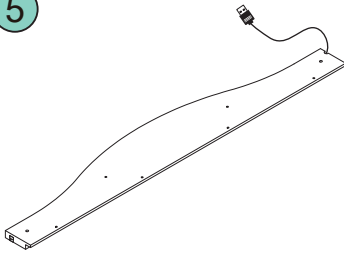
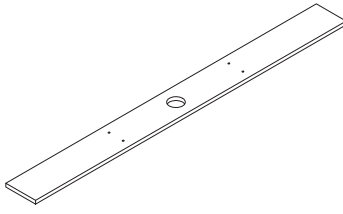
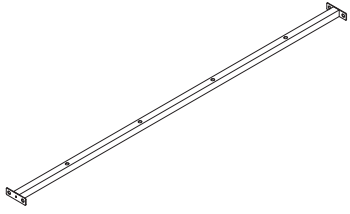
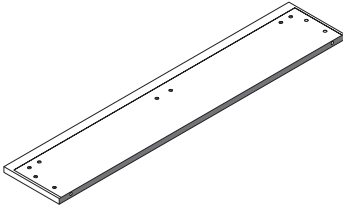
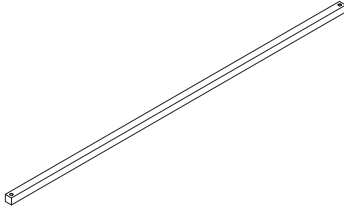
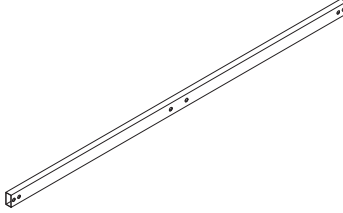
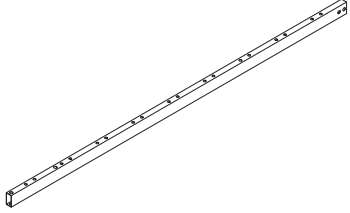
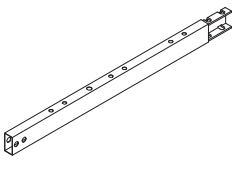
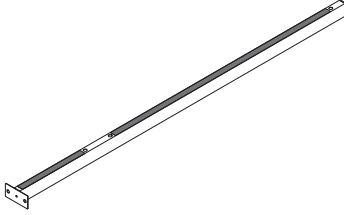
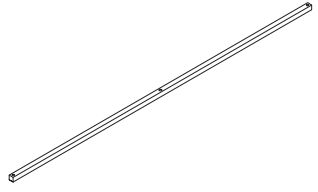
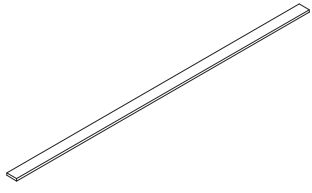
<p>4</p>  <p>x2</p>	<p>5</p>  <p>x1</p>	<p>6</p>  <p>x1</p>	<p>15</p>  <p>x1</p>
<p>18</p>  <p>x1</p>	<p>26</p>  <p>x1</p>	<p>34</p>  <p>x2</p>	<p>35</p>  <p>x2</p>
<p>36</p>  <p>x2</p>	<p>37</p>  <p>x1</p>	<p>38</p>  <p>x1</p>	<p>40</p>  <p>x1</p>
<p>43</p>  <p>x12</p>			

STEP 1

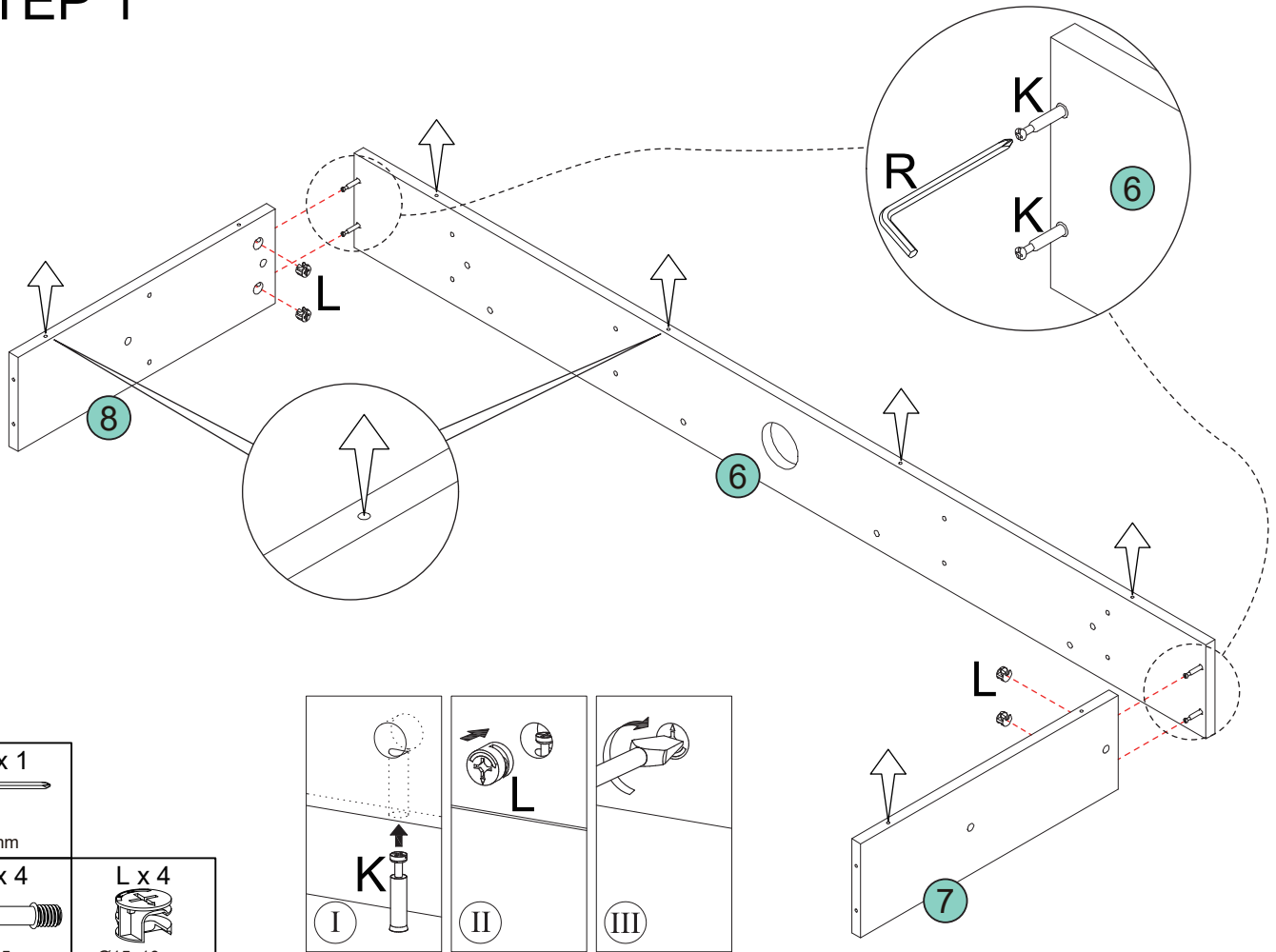

STEP 2

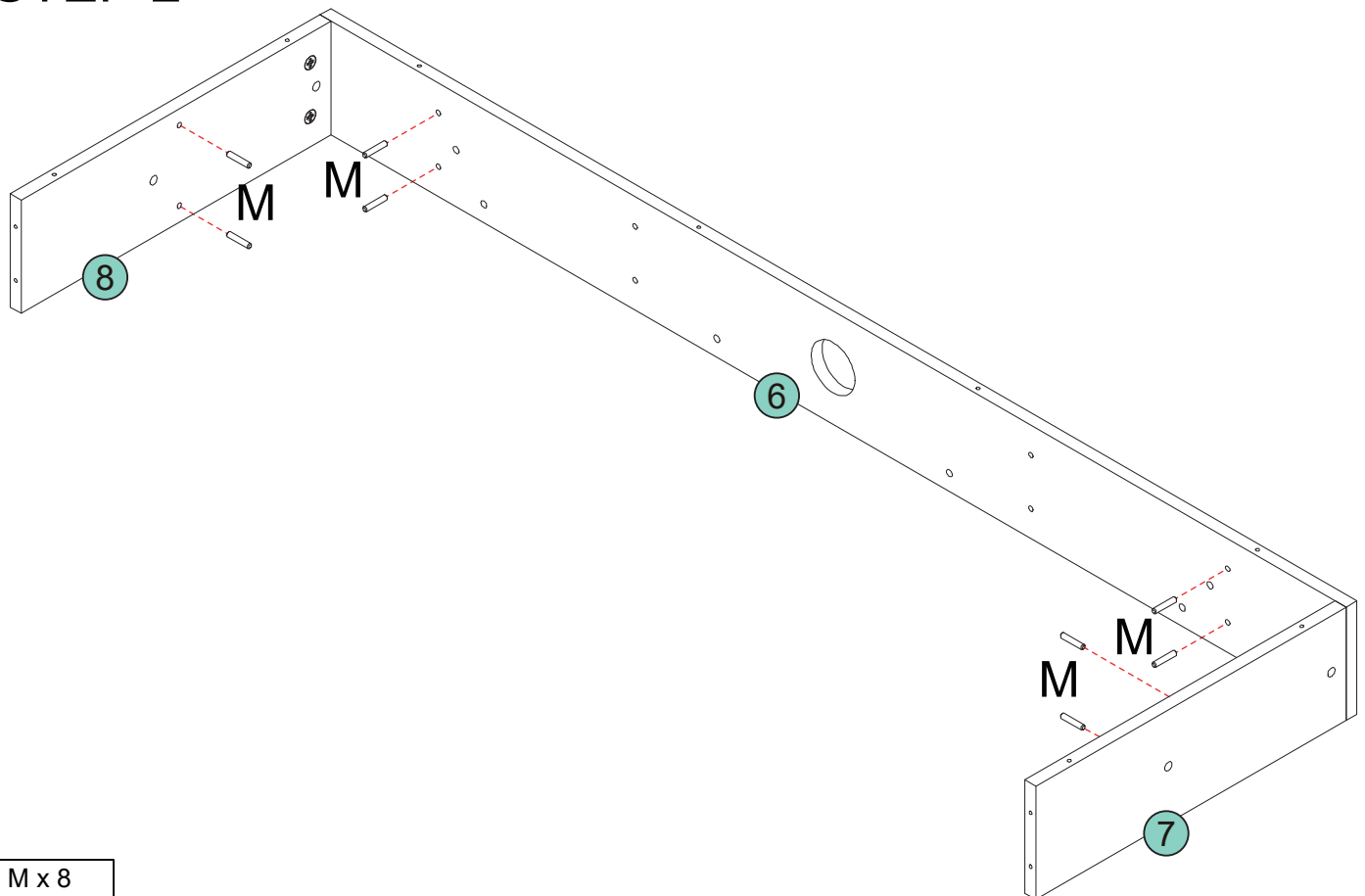

STEP 3

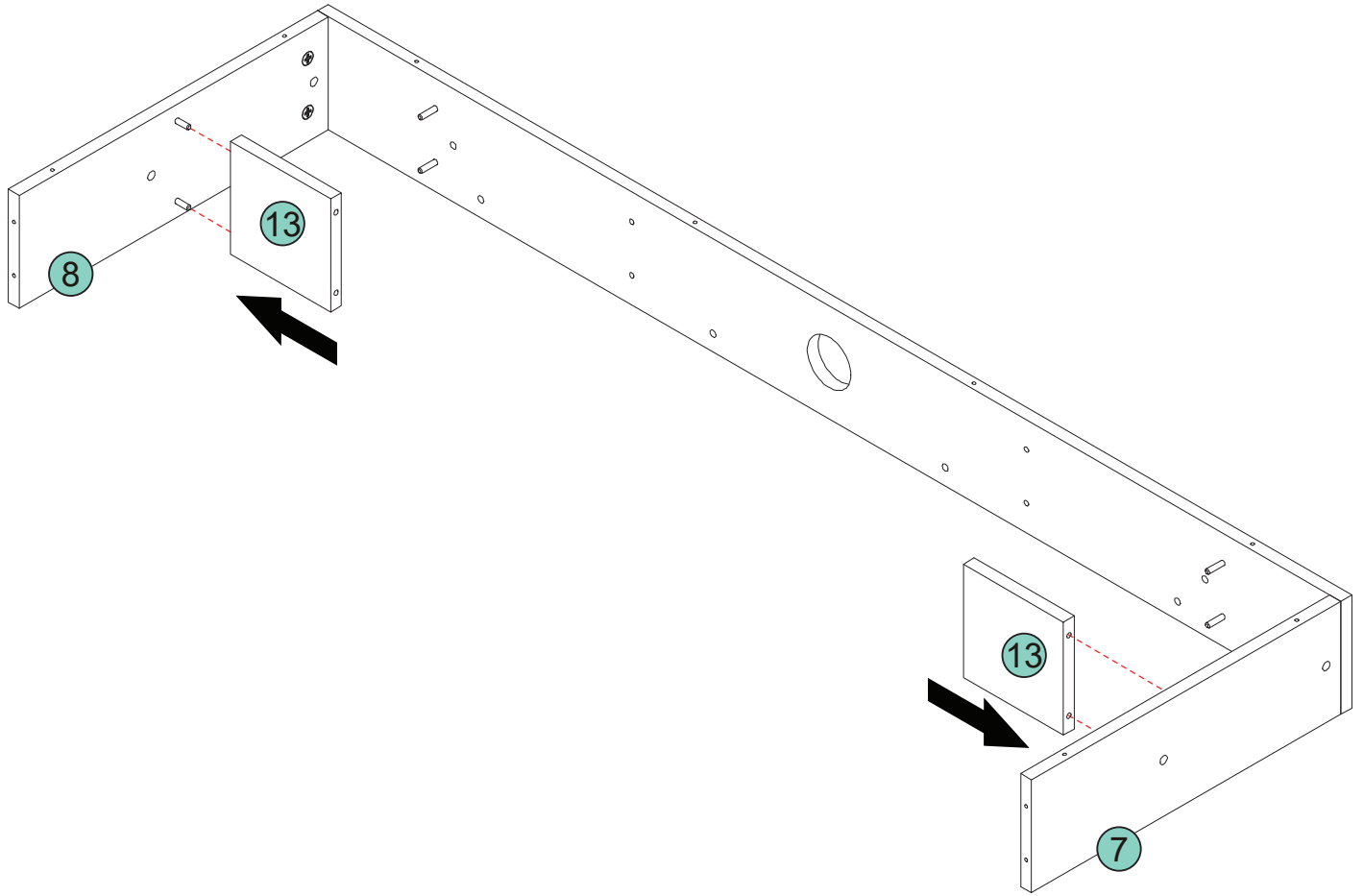

STEP 4

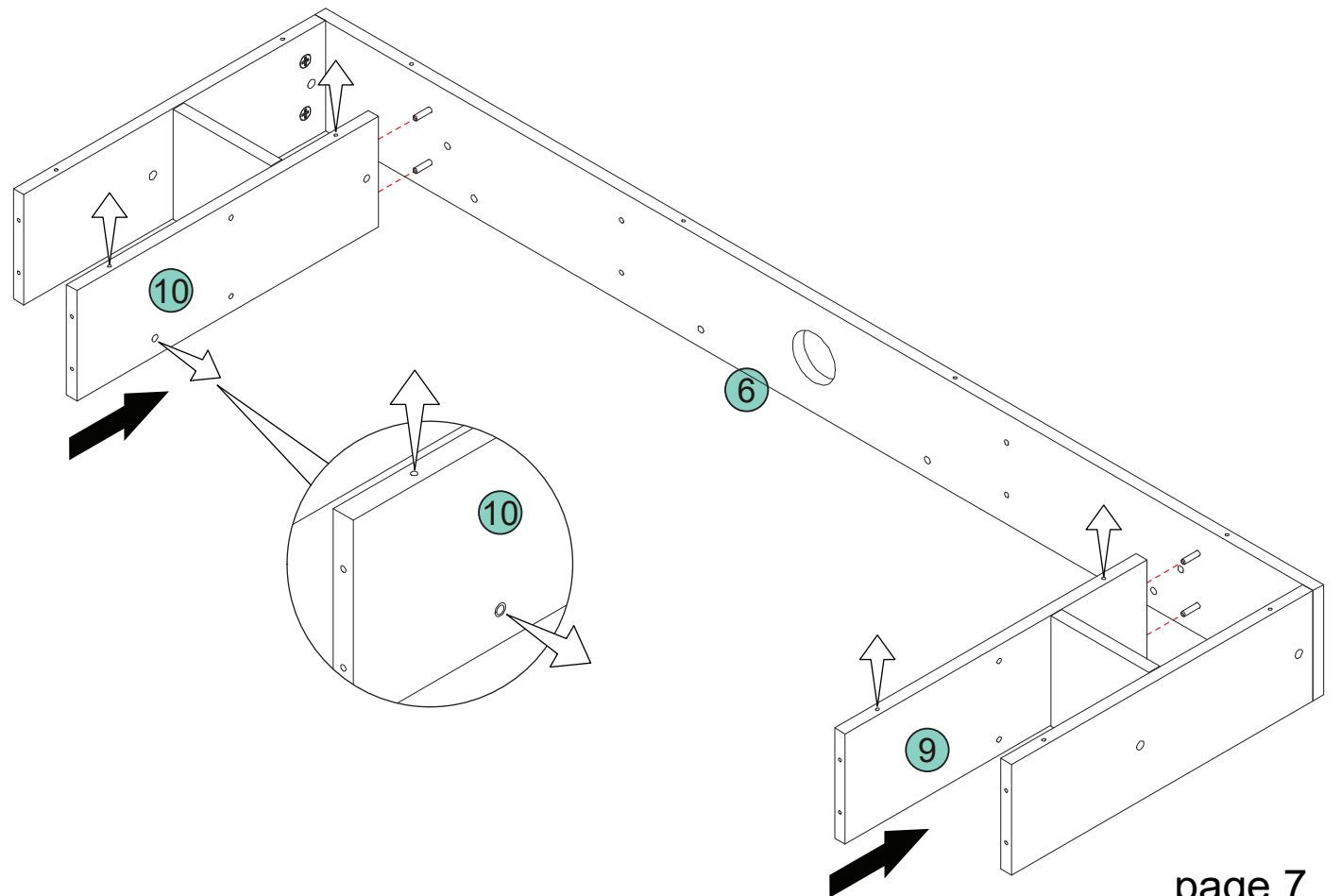

STEP 5

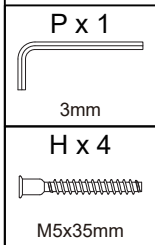
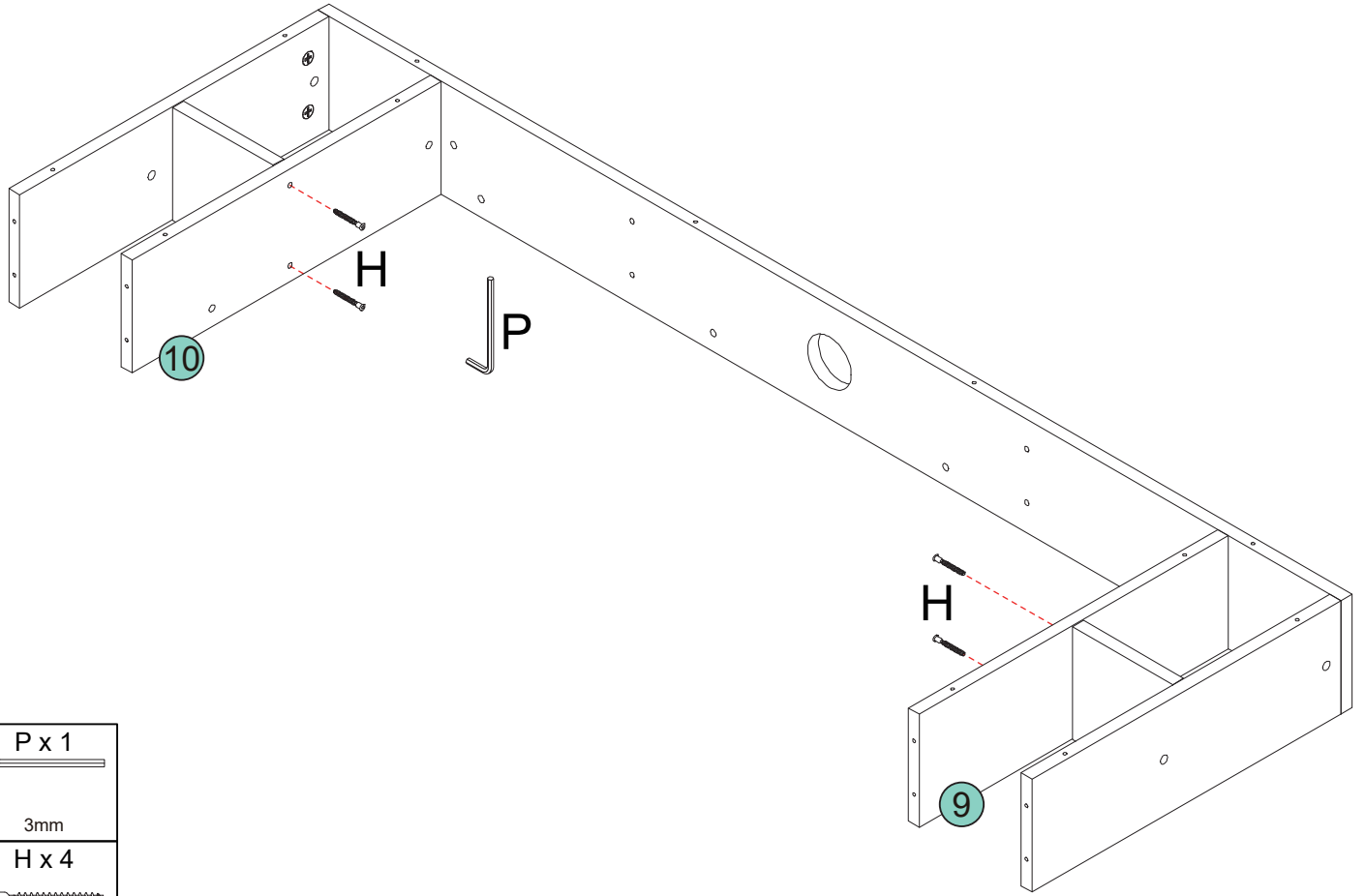

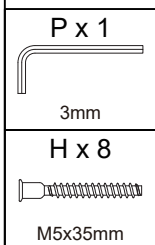
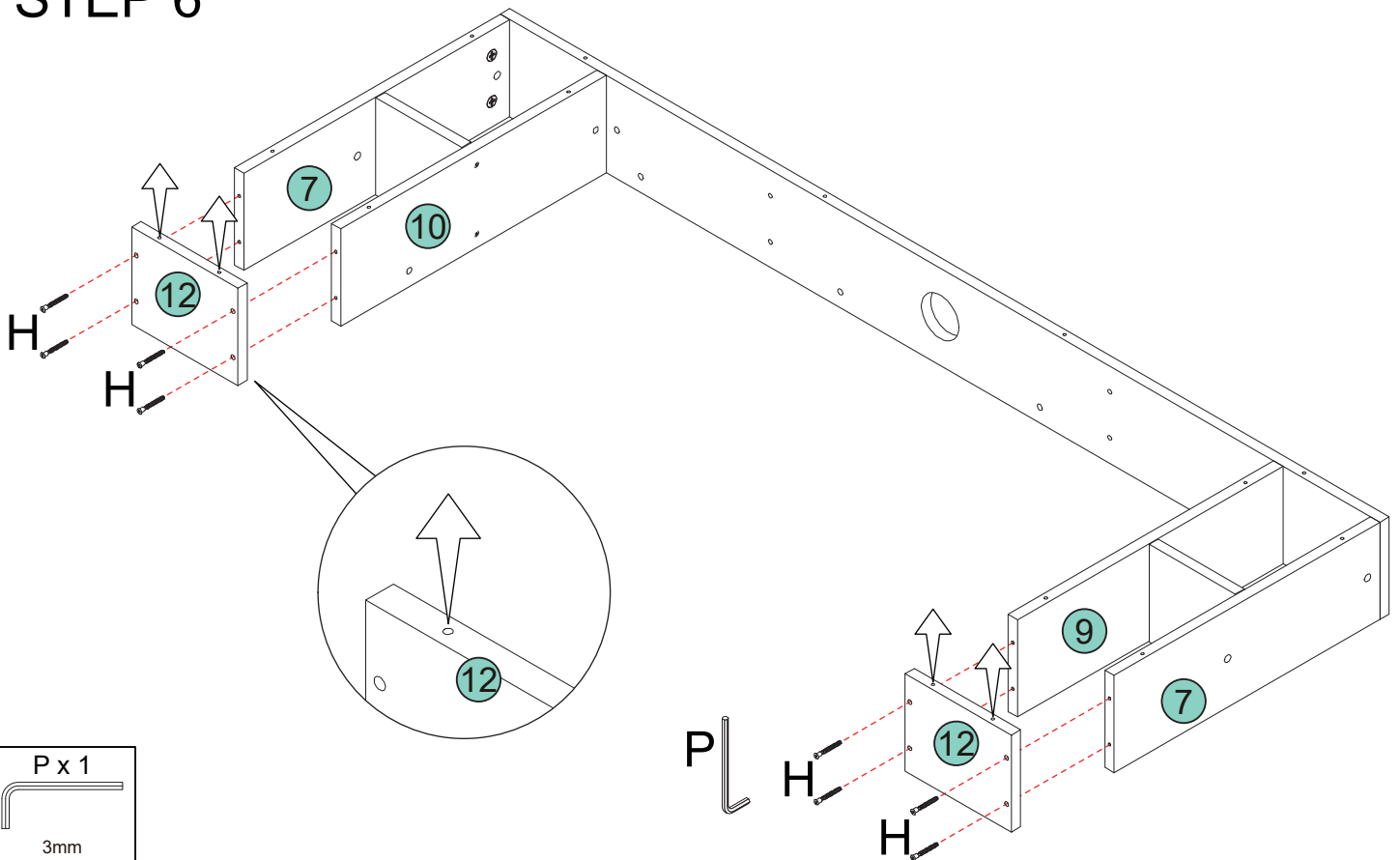

STEP 6



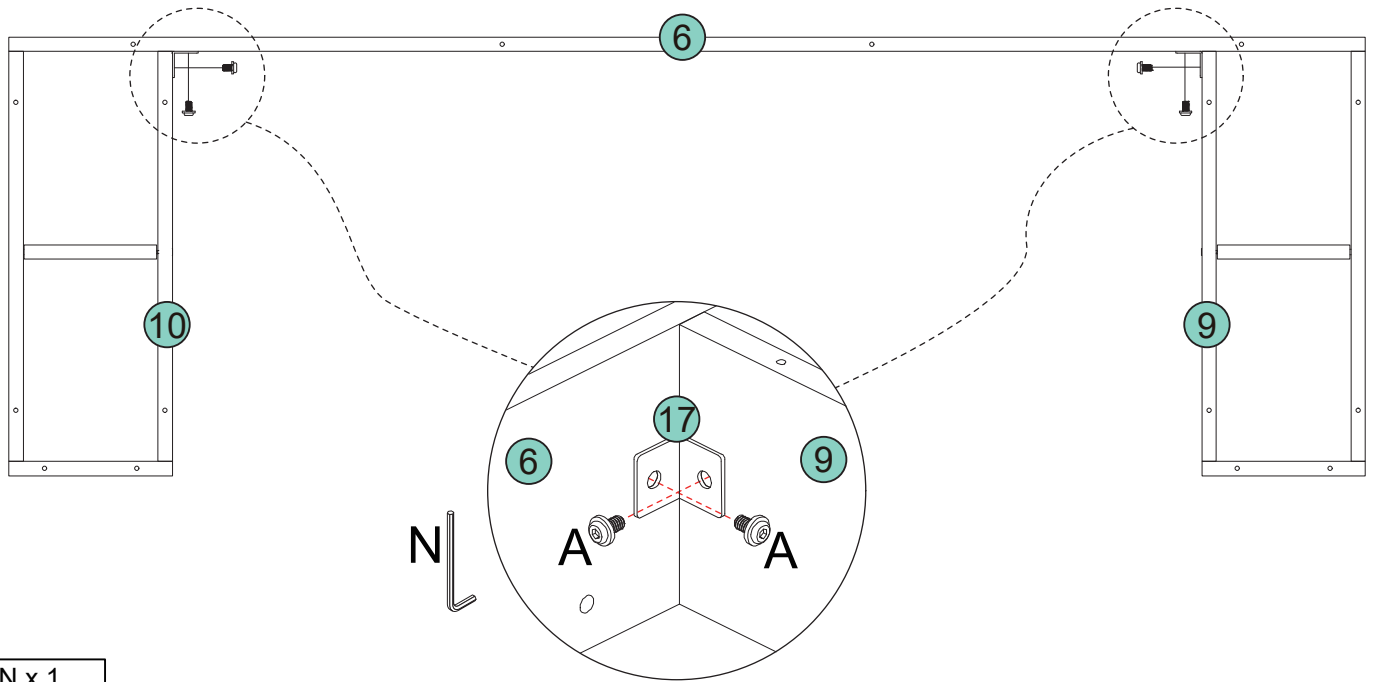



STEP 7

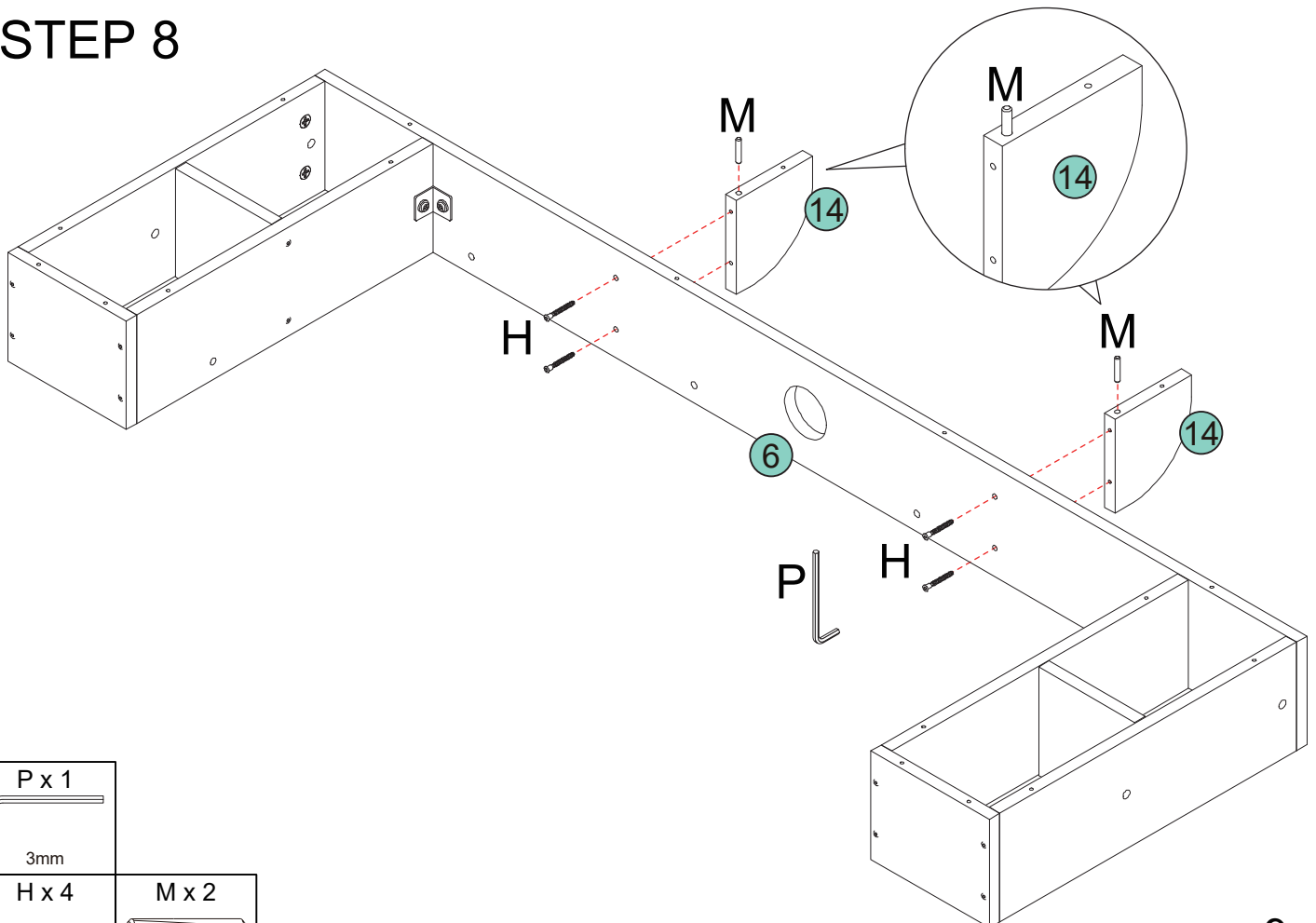

N x 1	
	
4mm	
A x 4	17 x 2
	
1/4"x13mm	



STEP 8



P x 1	
	
3mm	
H x 4	M x 2
	
M5x35mm	Ø6x30mm

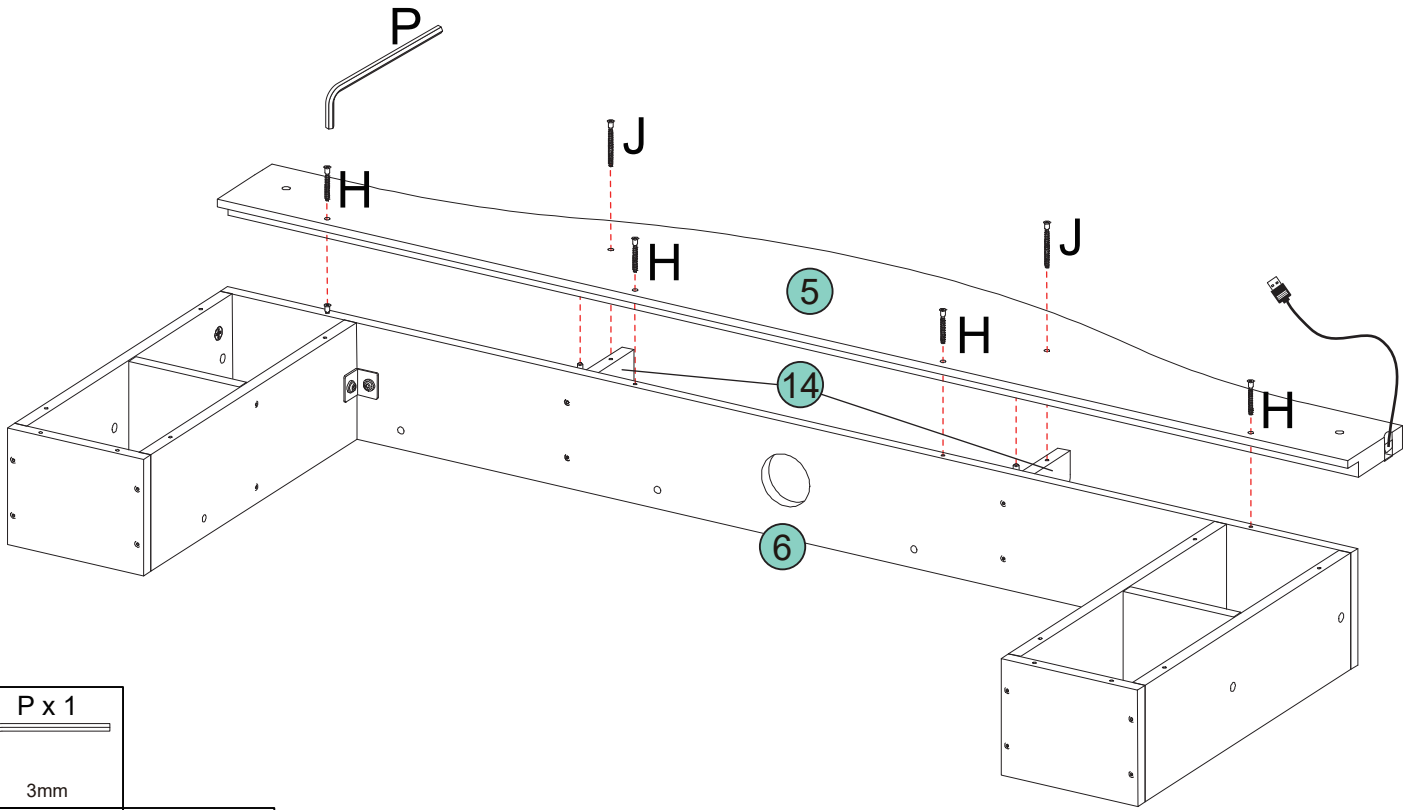

STEP 9

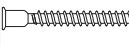

P x 1  3mm	
H x 4  M5x35mm	J x 2  M5x50mm

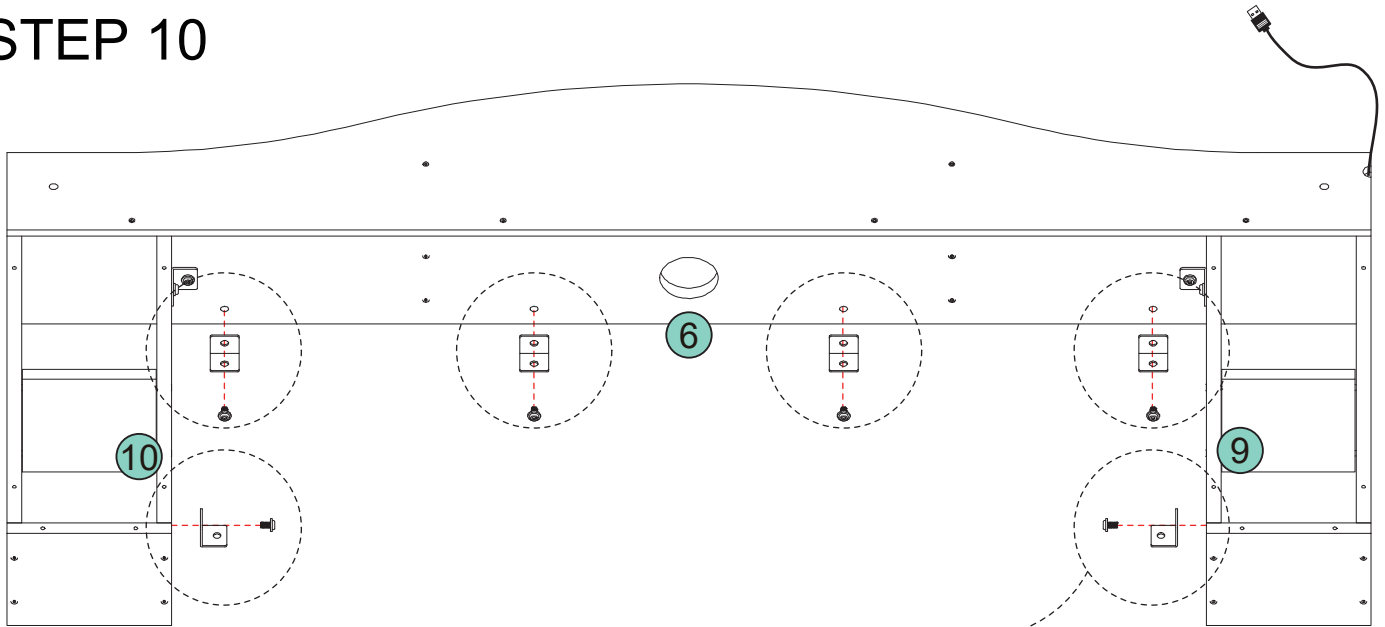
STEP 10

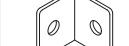

N x 1  4mm	
A x 6  1/4"x13mm	17 x 6 

75%
tighten

STEP 11

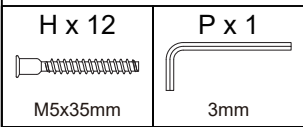
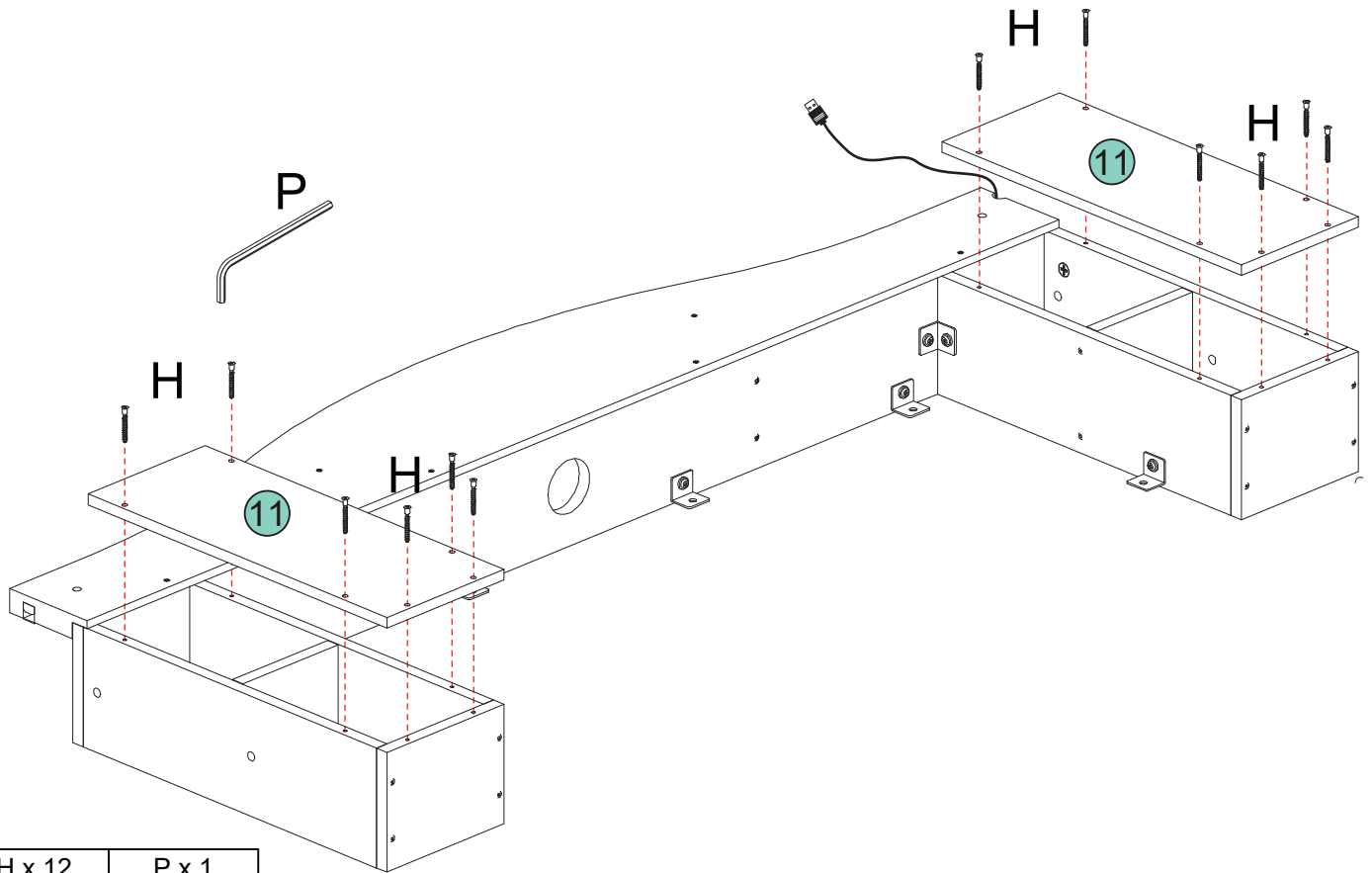

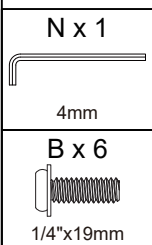
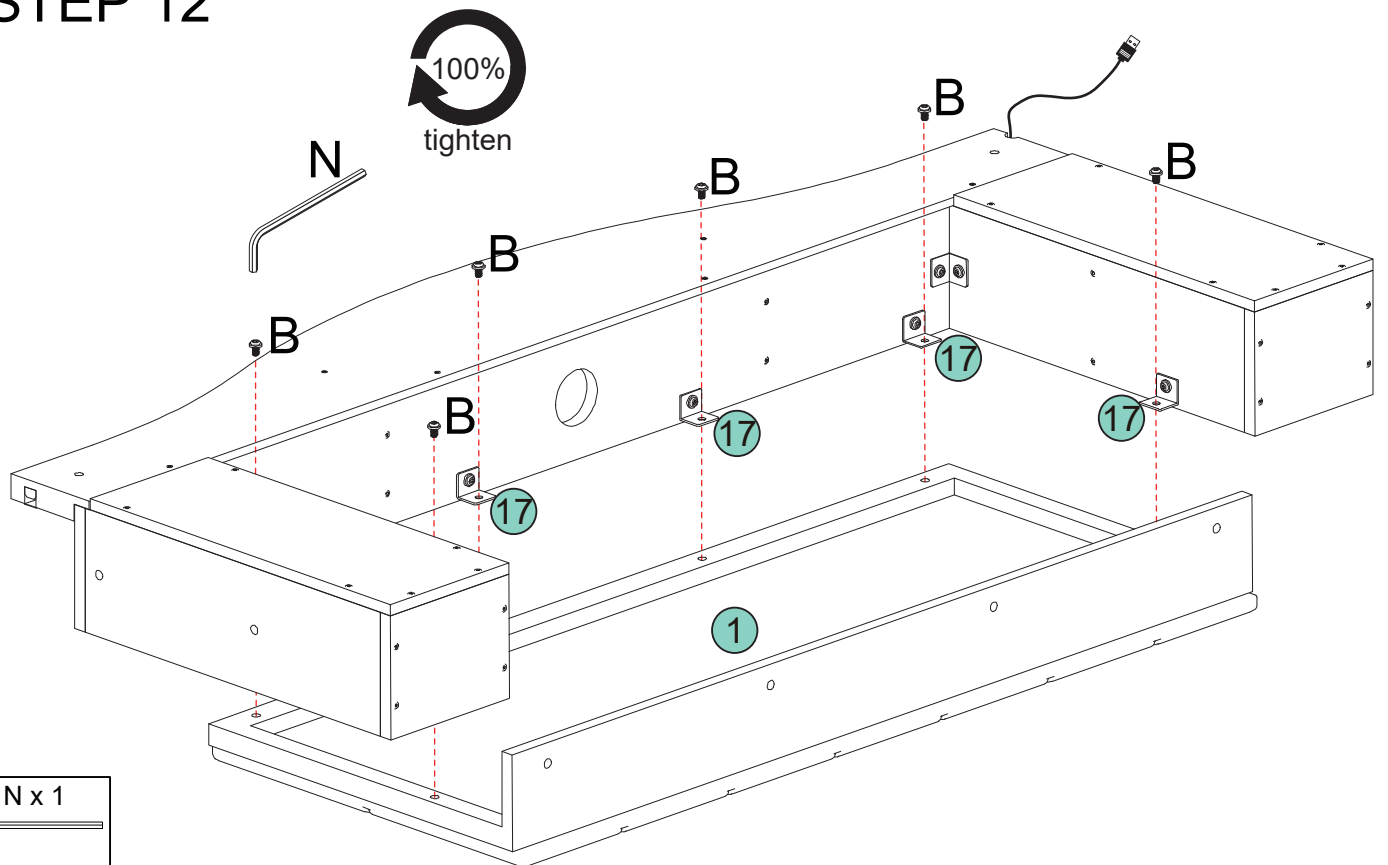

STEP 12



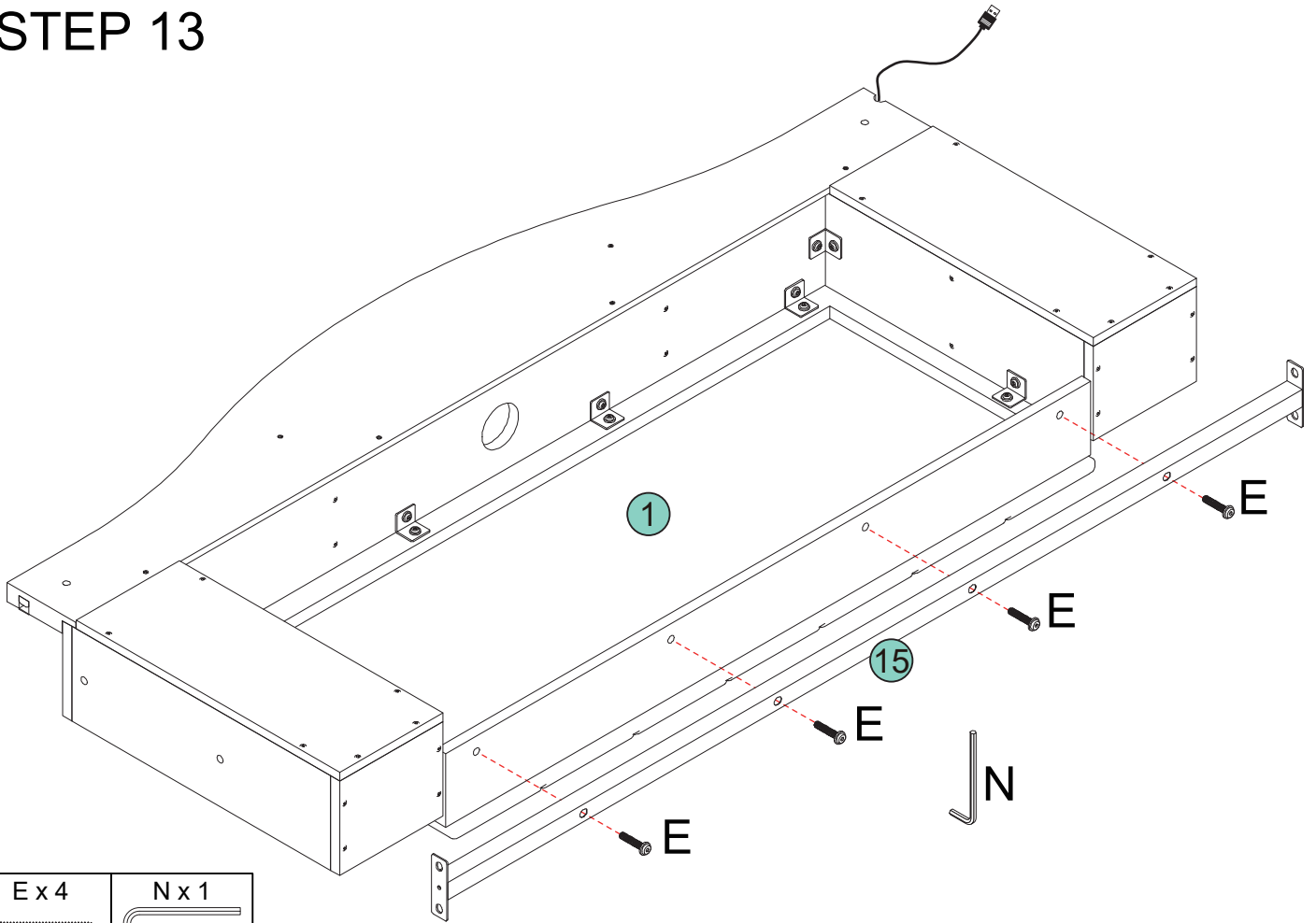



STEP 13

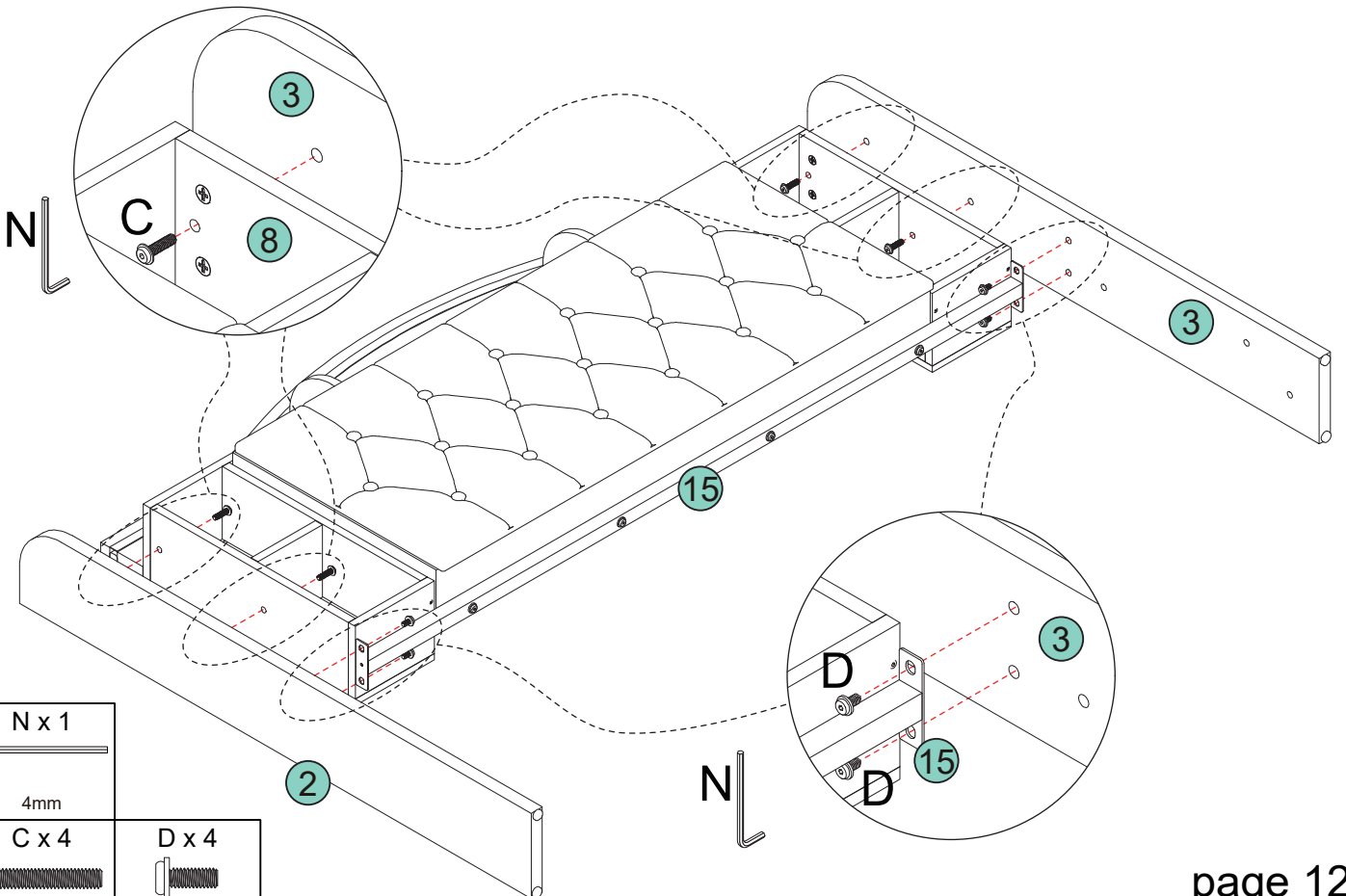

E x 4	N x 1
	
5/16"x40mm	4mm



STEP 14



N x 1	
	
4mm	
C x 4	D x 4
	
5/16"x35mm	5/16"x16mm

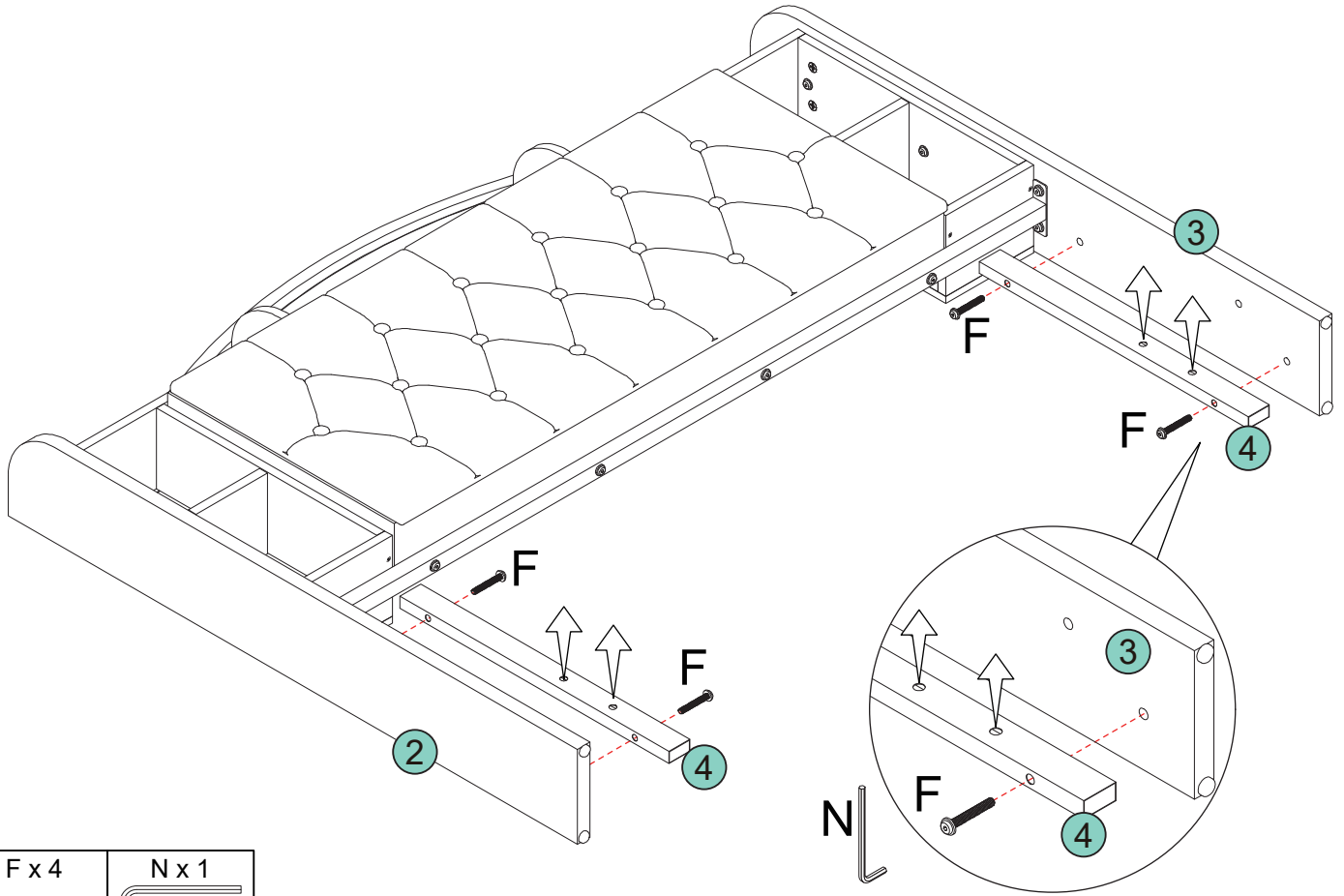

STEP 15

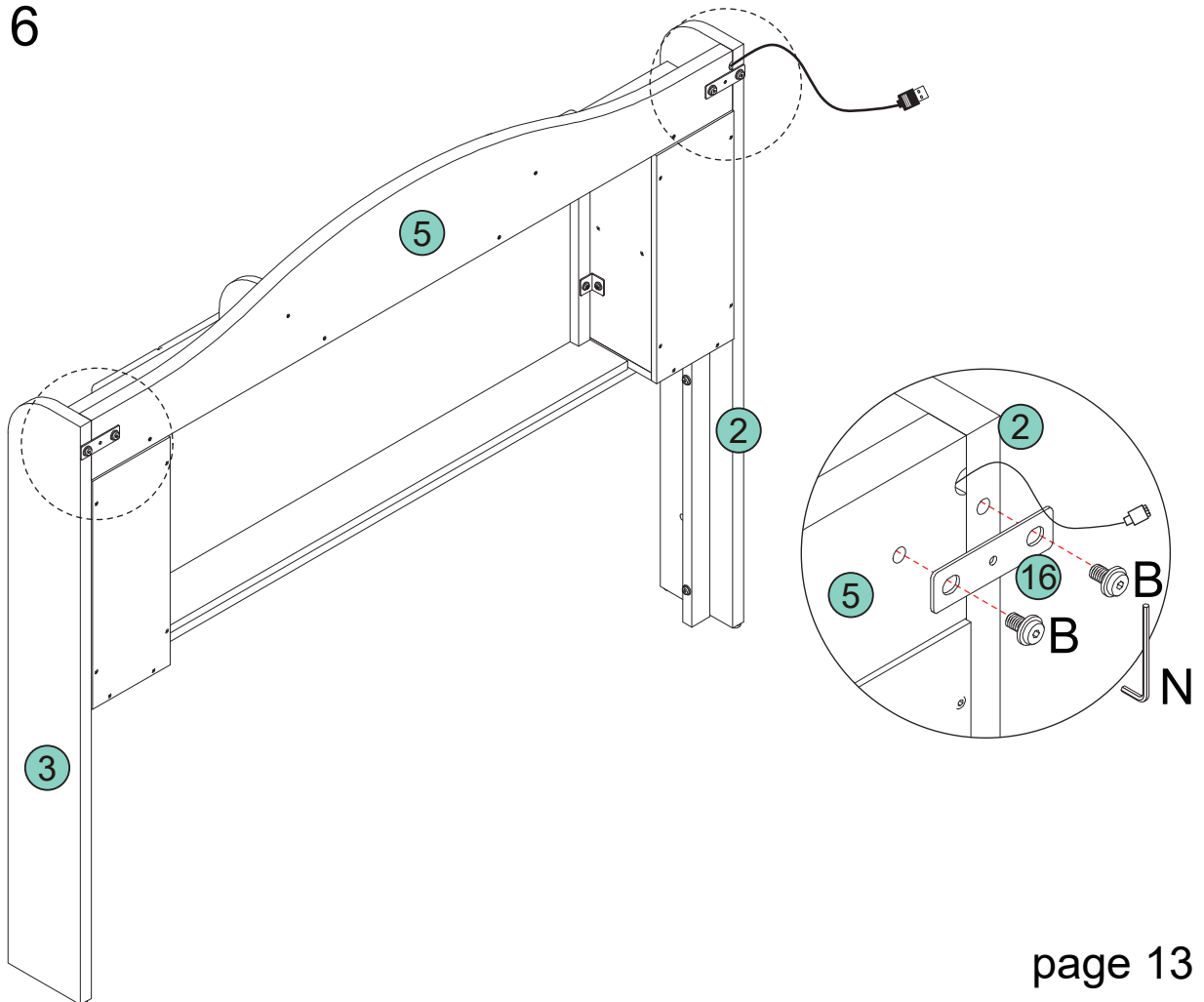

F x 4  5/16"x55mm	N x 1  4mm
--	--

STEP 16

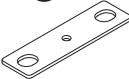

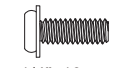
16 x 2 
N x 1  4mm
B x 4  1/4"x19mm

STEP 17

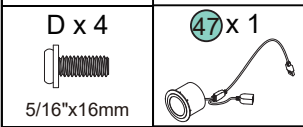
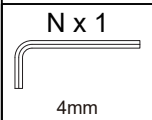
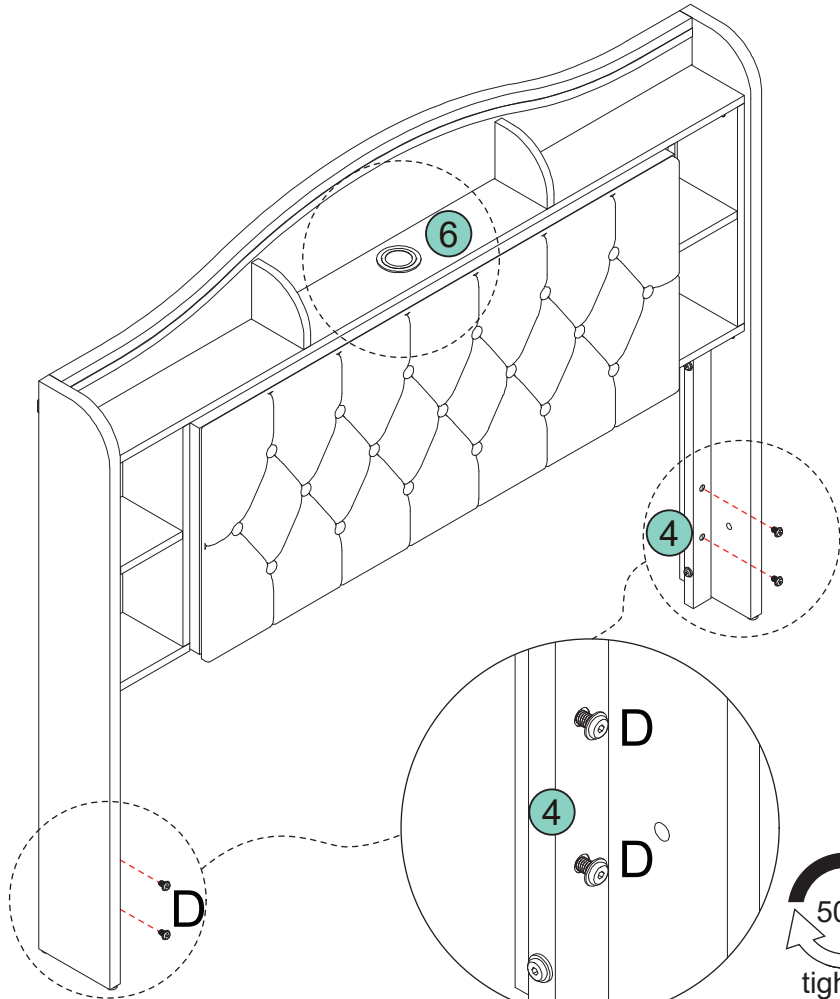
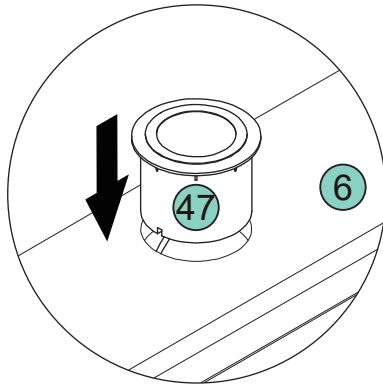

STEP 18

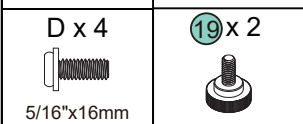
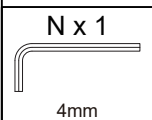
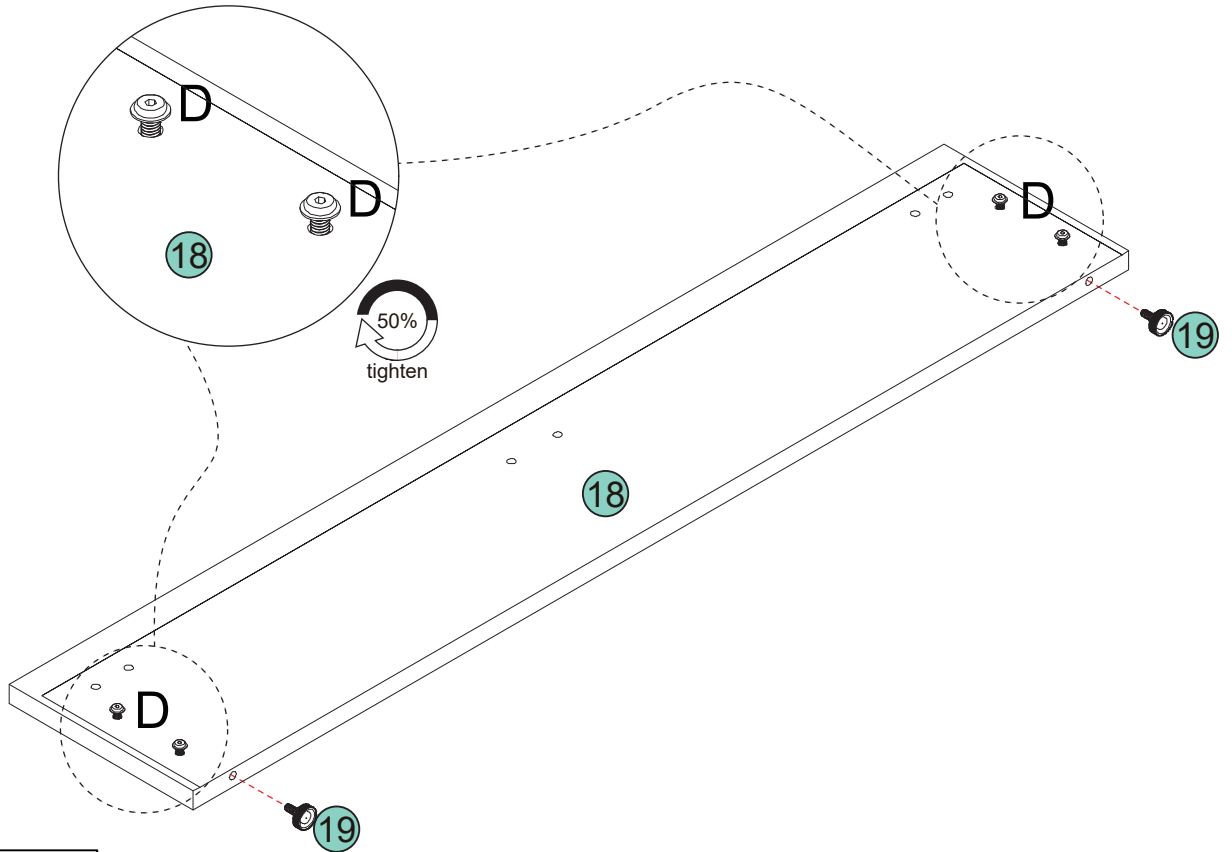

STEP 19

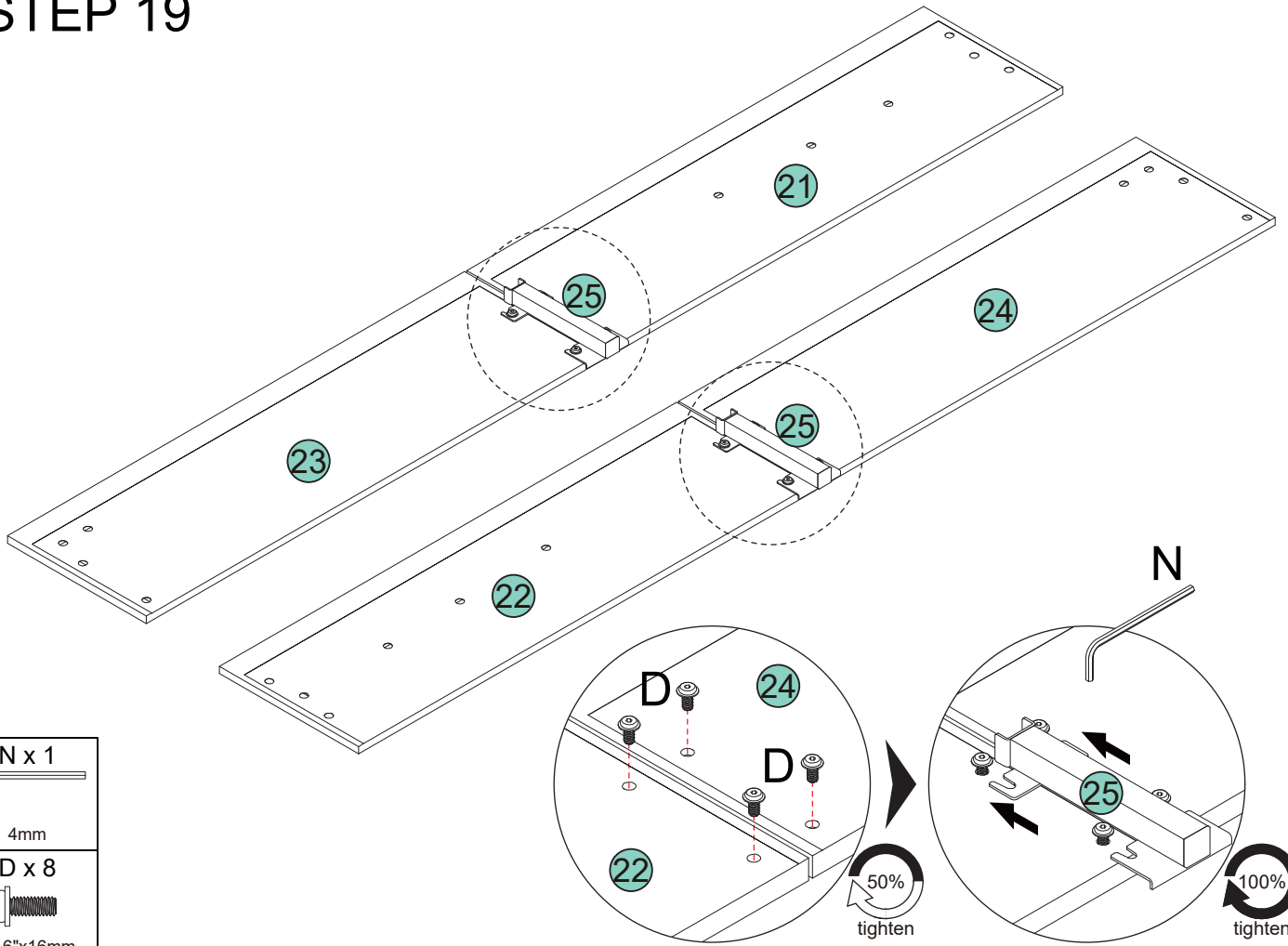

STEP 20

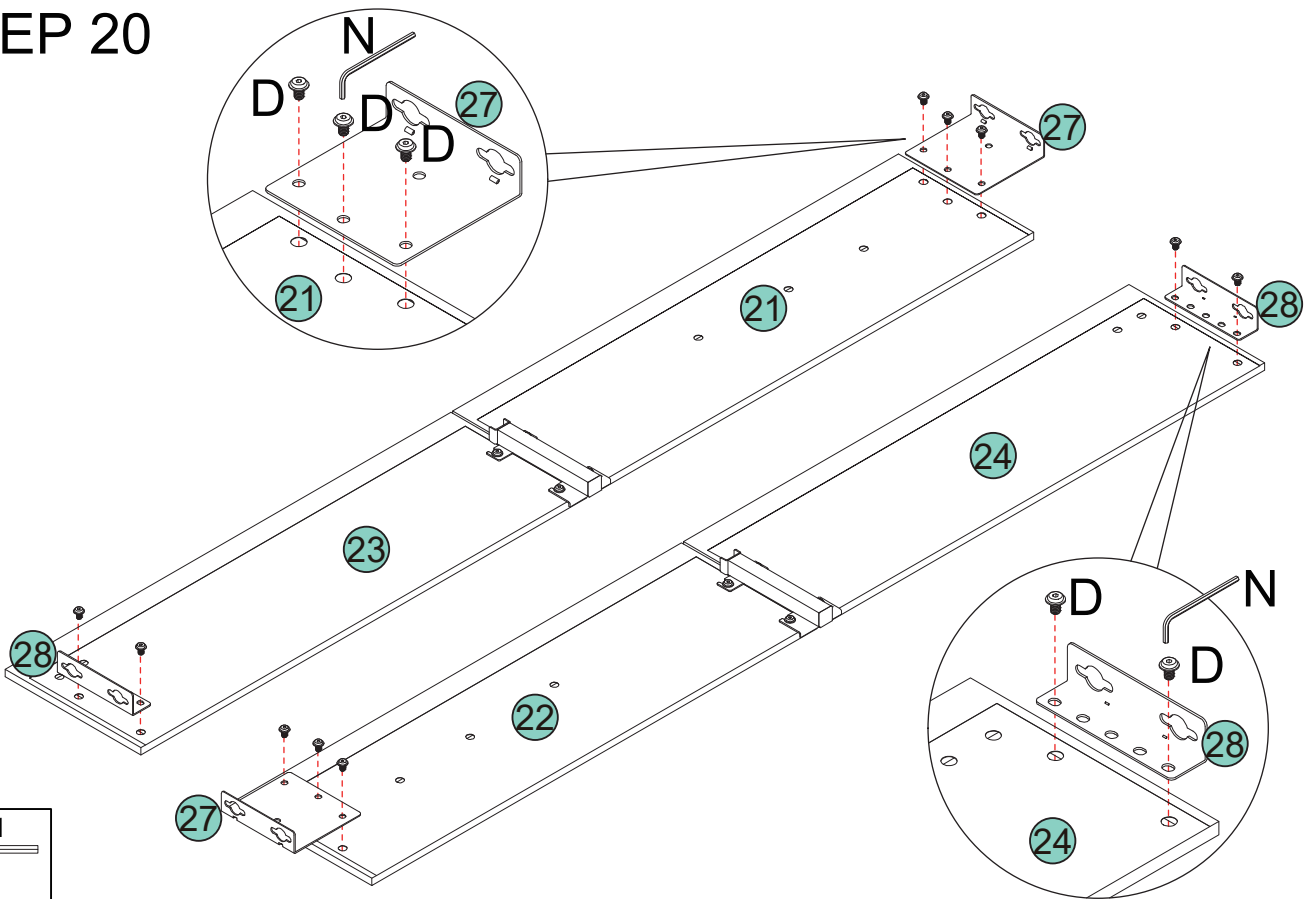

STEP 21

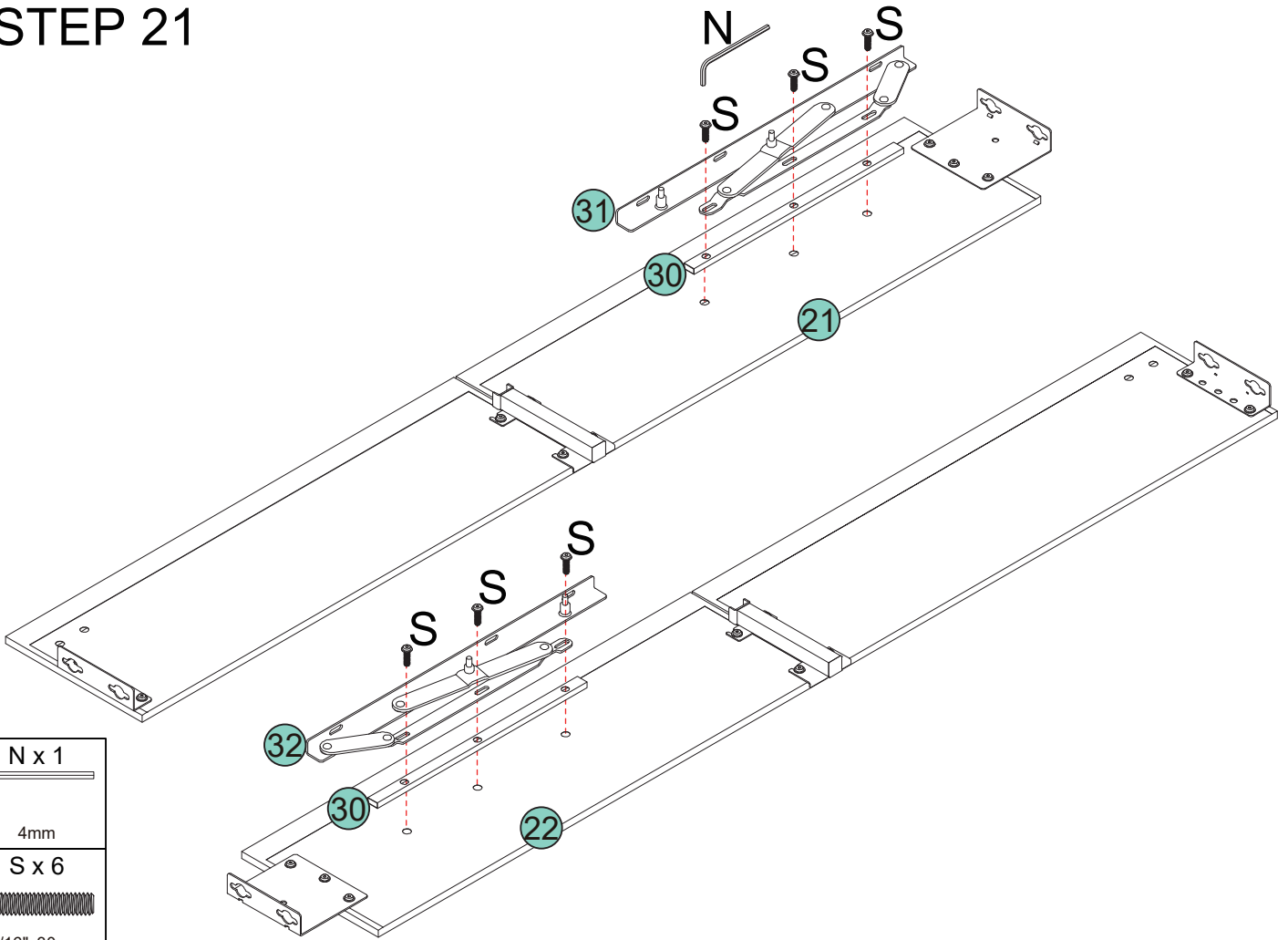

STEP 22

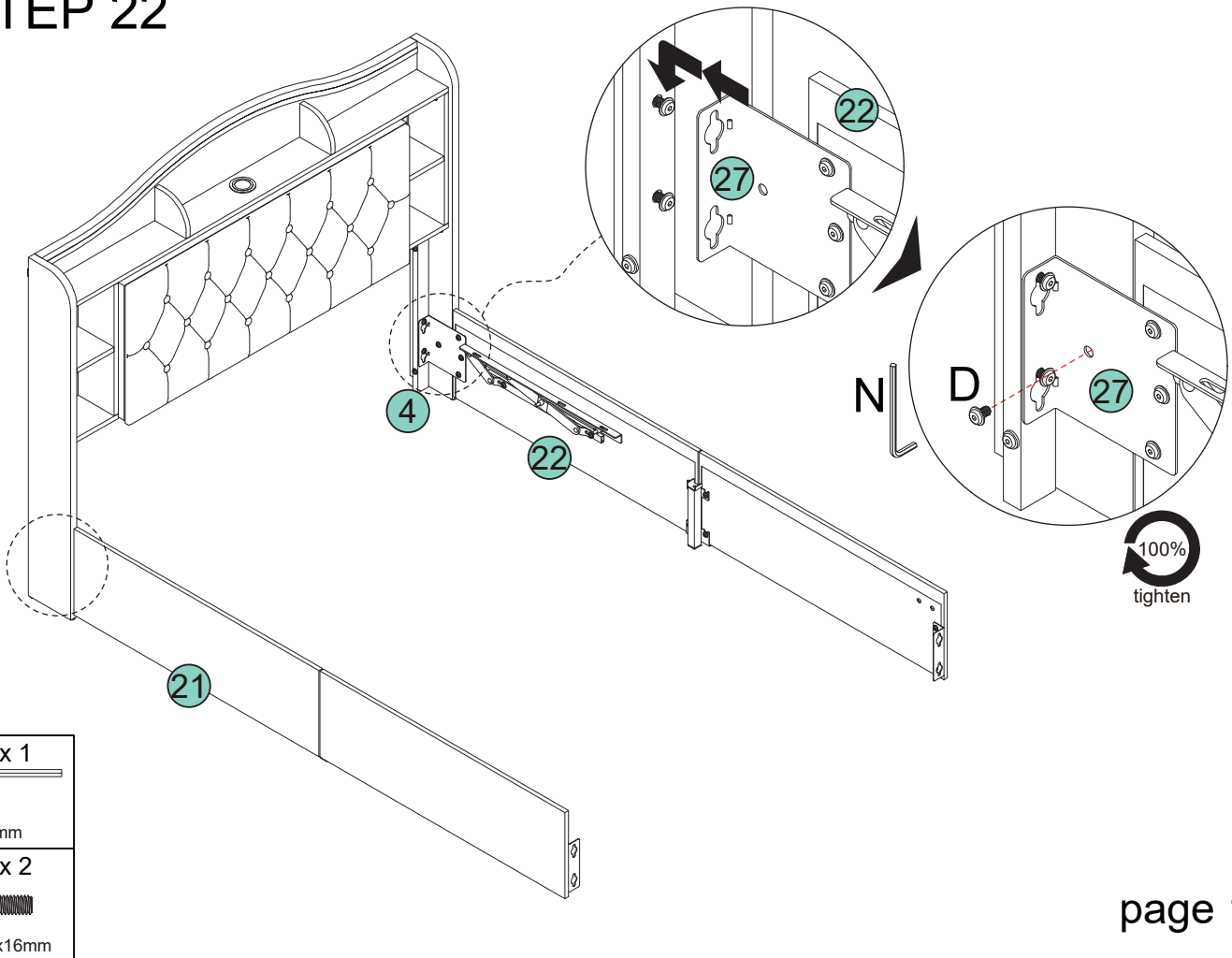

STEP 23

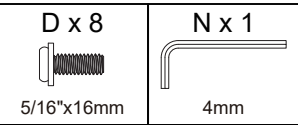
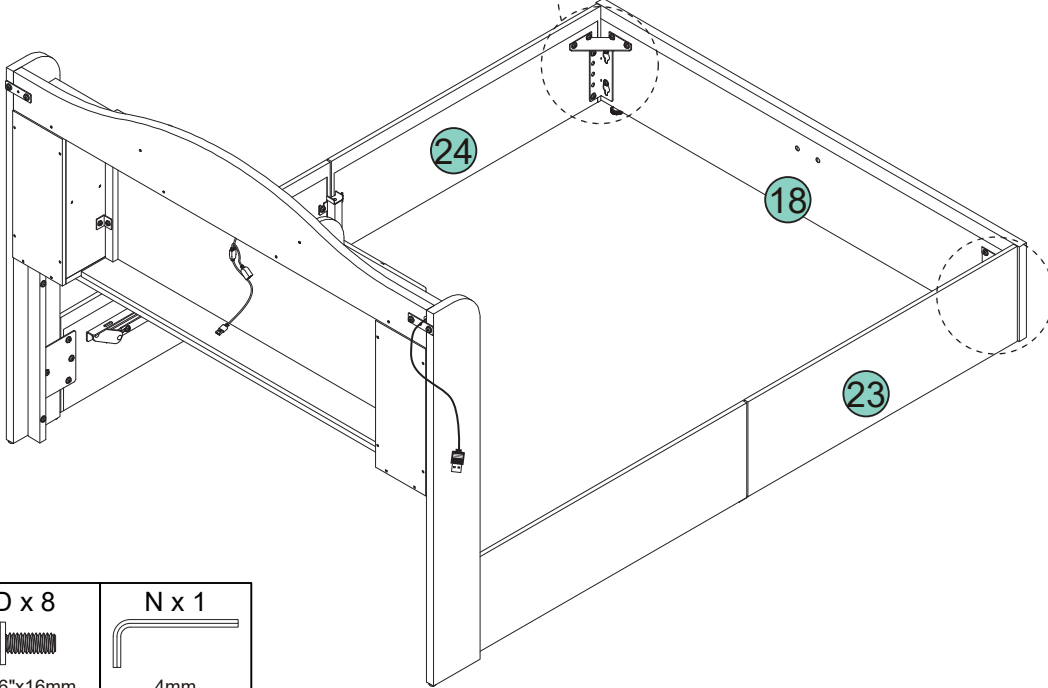
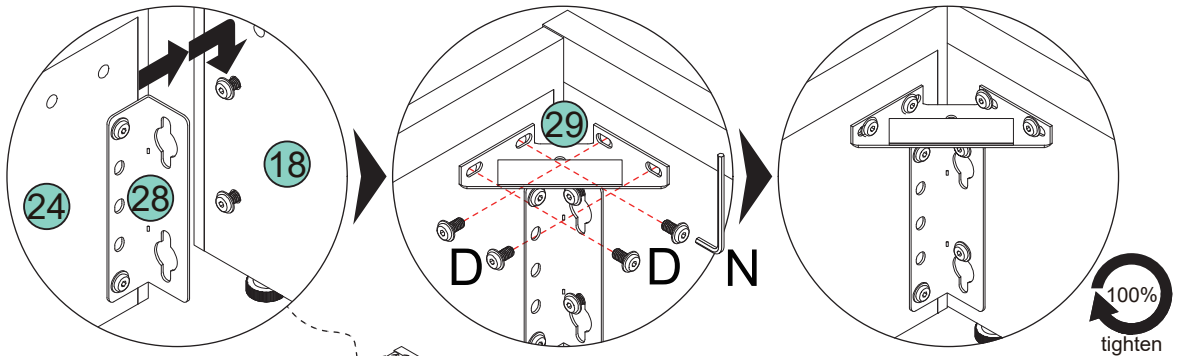

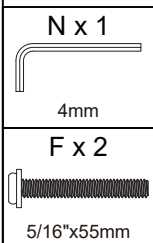
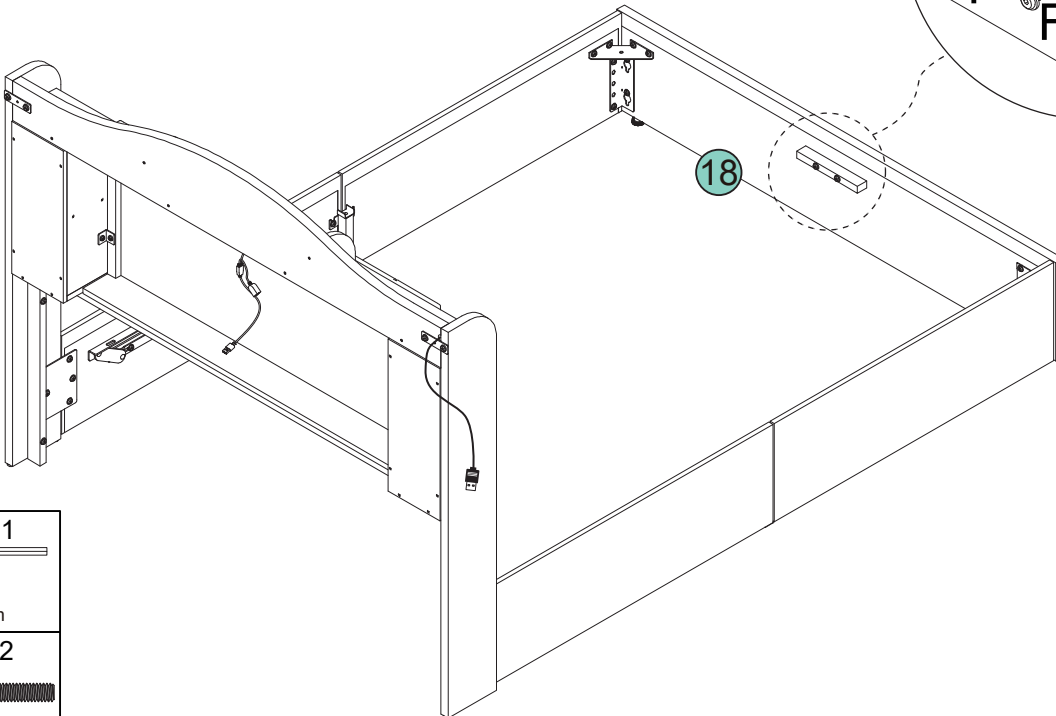
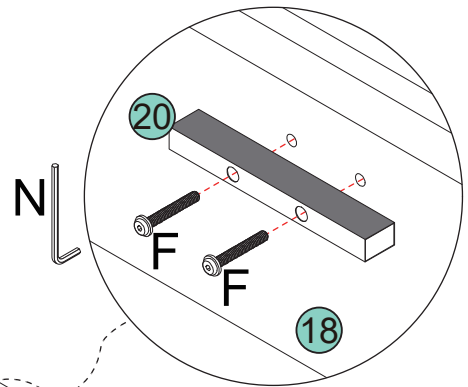

STEP 24

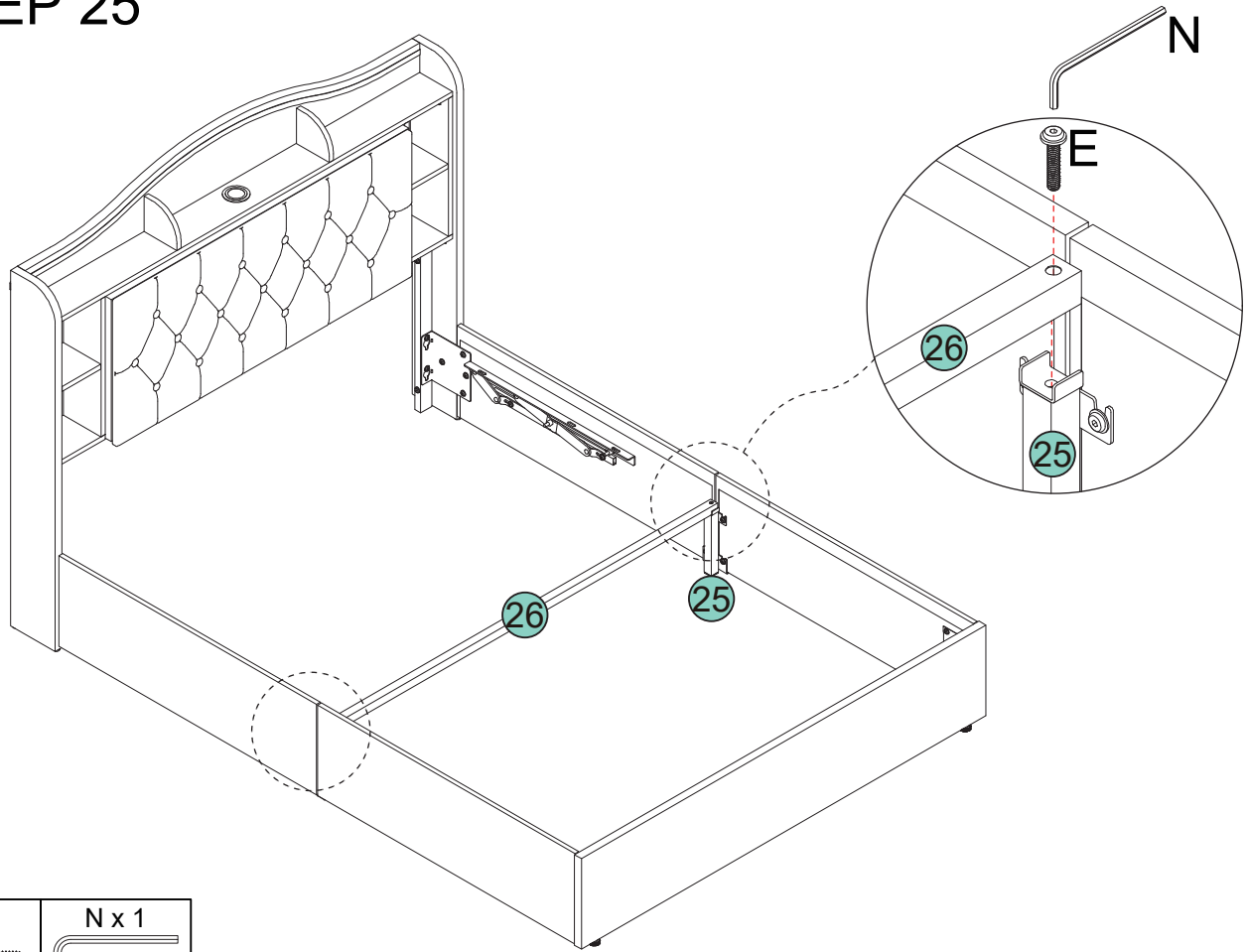

STEP 25



E x 2	N x 1
	
5/16"x40mm	4mm

STEP 26

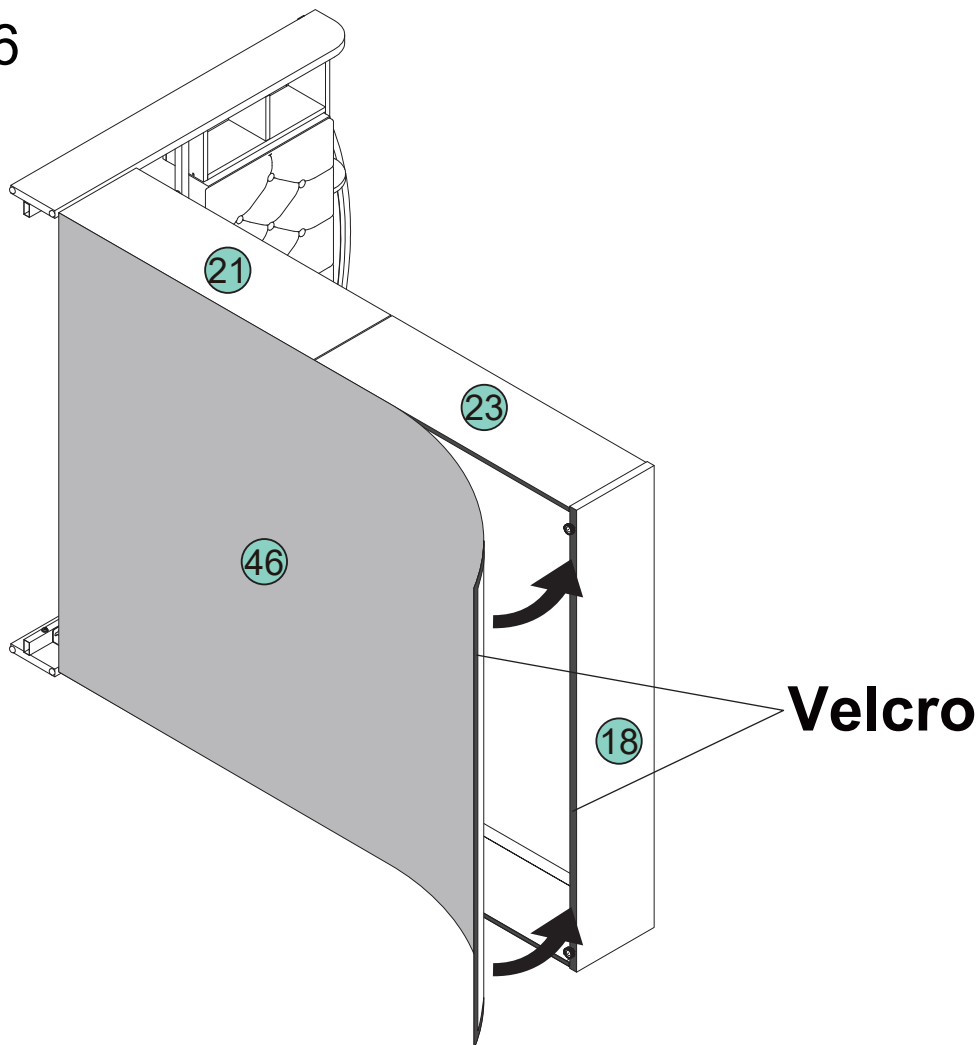

STEP 27

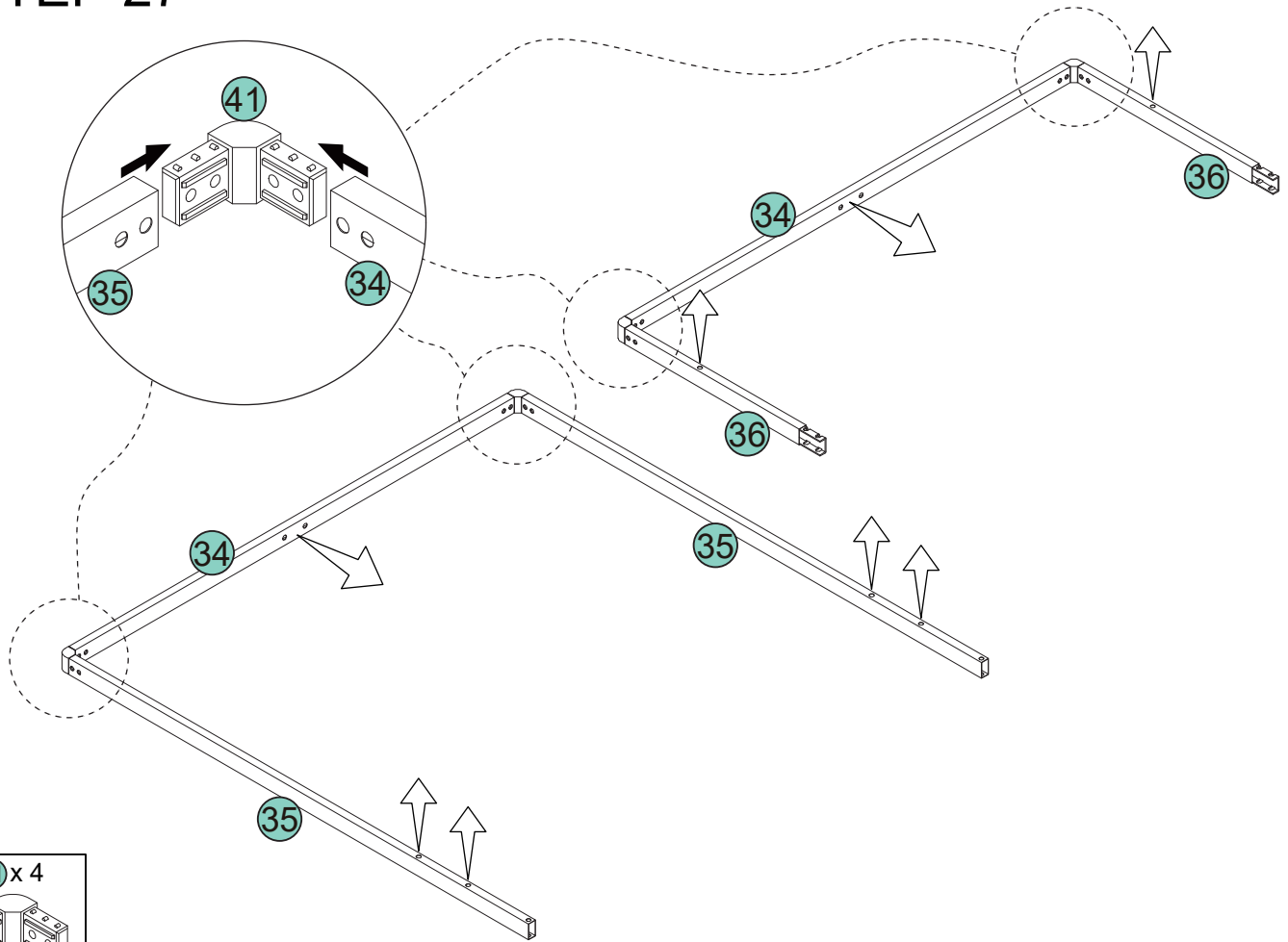

STEP 28

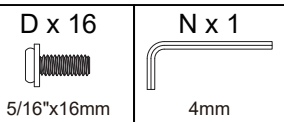
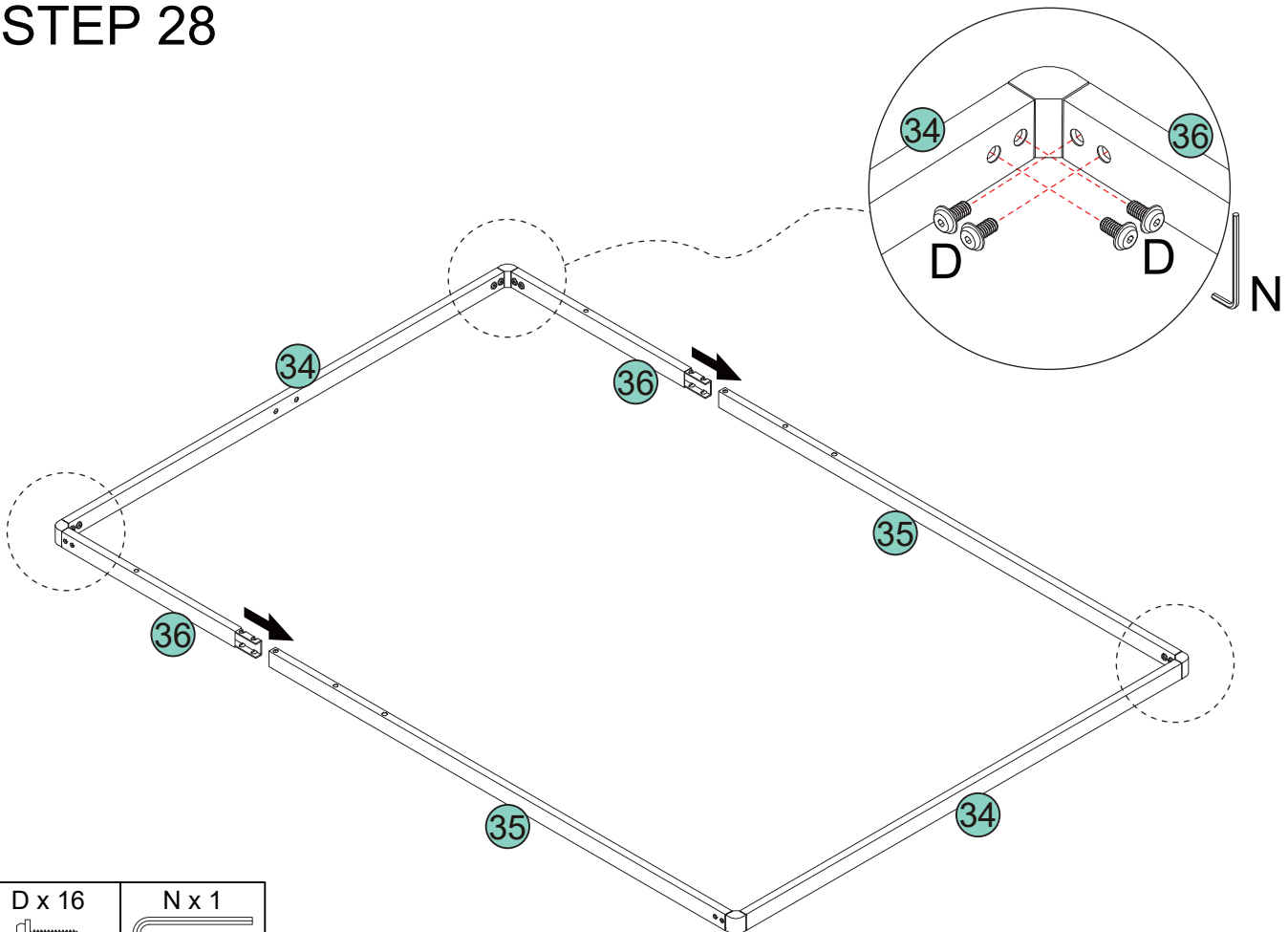

STEP 29

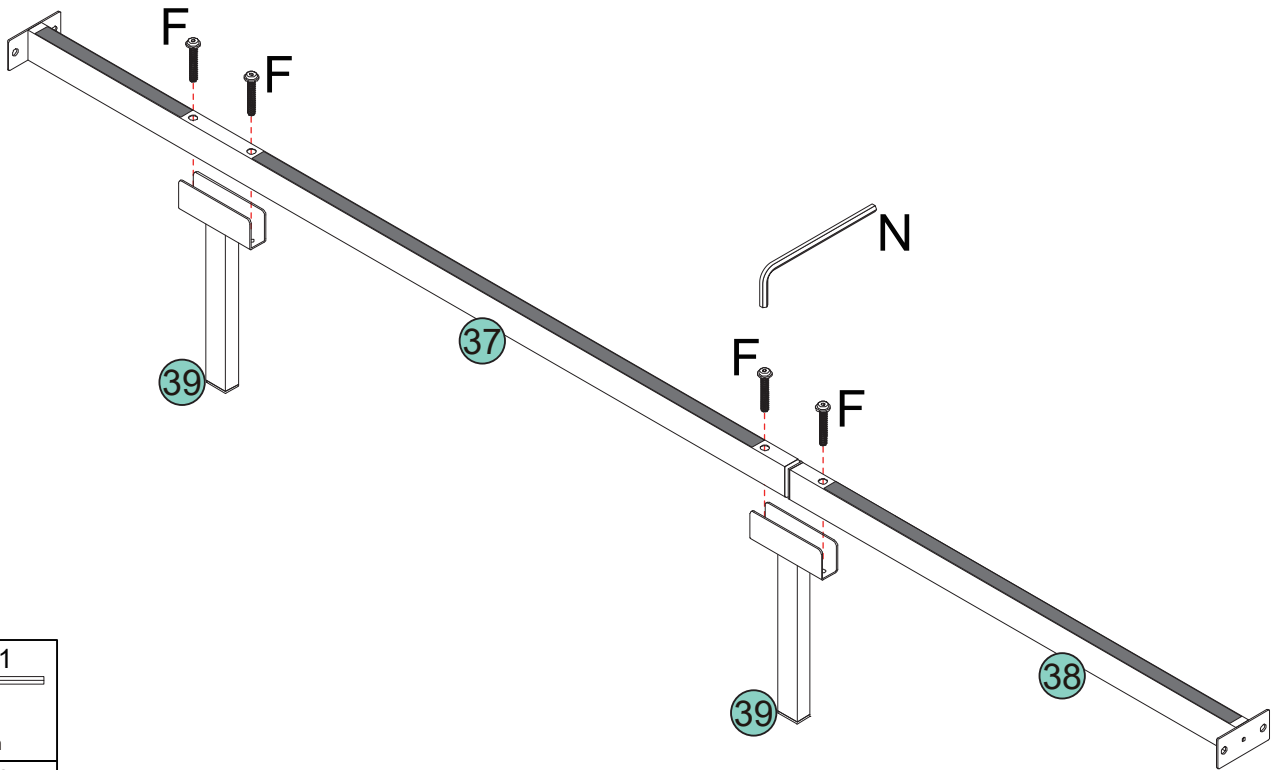

- N x 1
4mm
- F x 2
5/16"x55mm

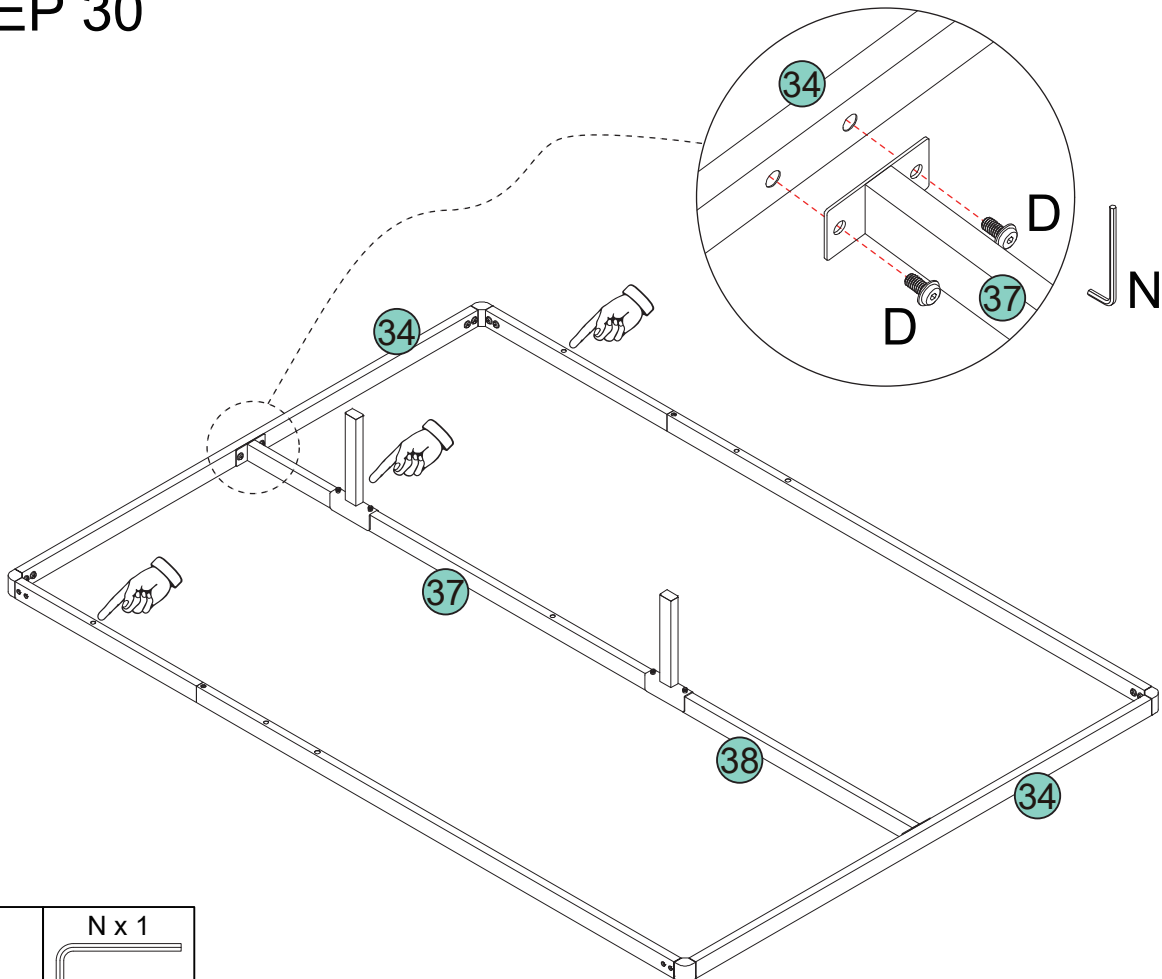

STEP 30



- D x 4
5/16"x16mm
- N x 1
4mm

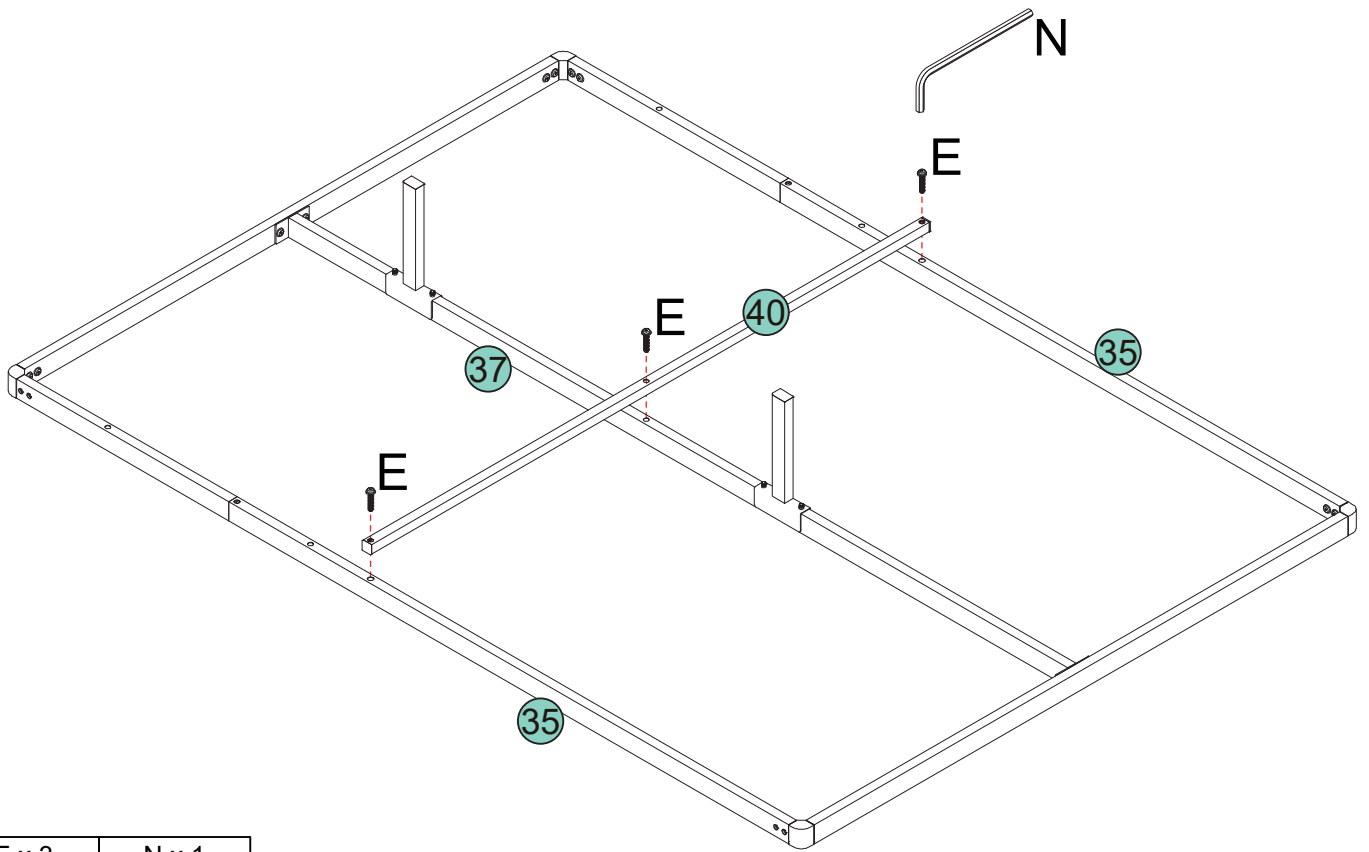



STEP 31

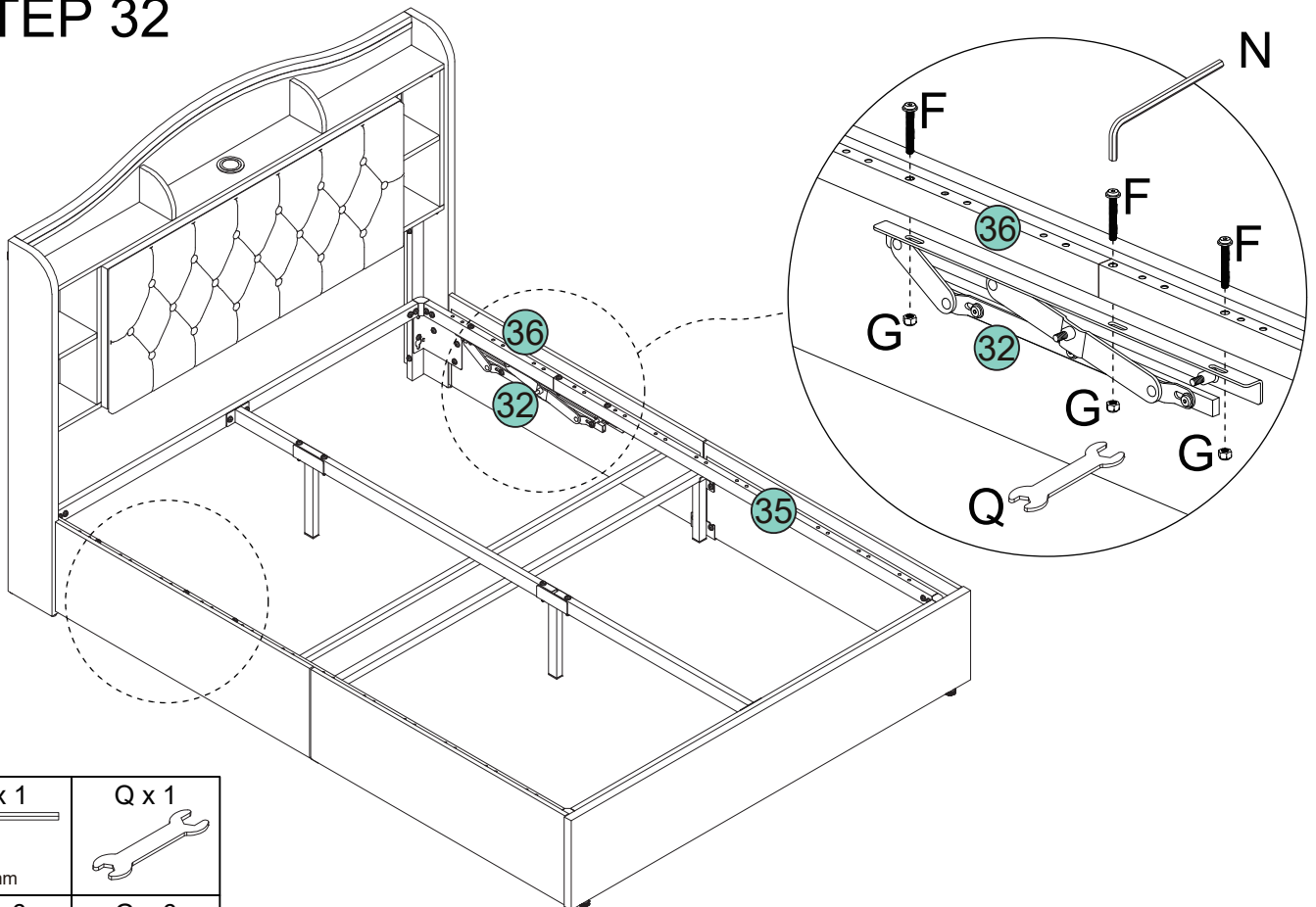

E x 3	N x 1
	
5/16"x40mm	4mm

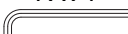
STEP 32



N x 1	Q x 1
	
4mm	
F x 6	G x 6
	
5/16"x55mm	5/16"

STEP 33

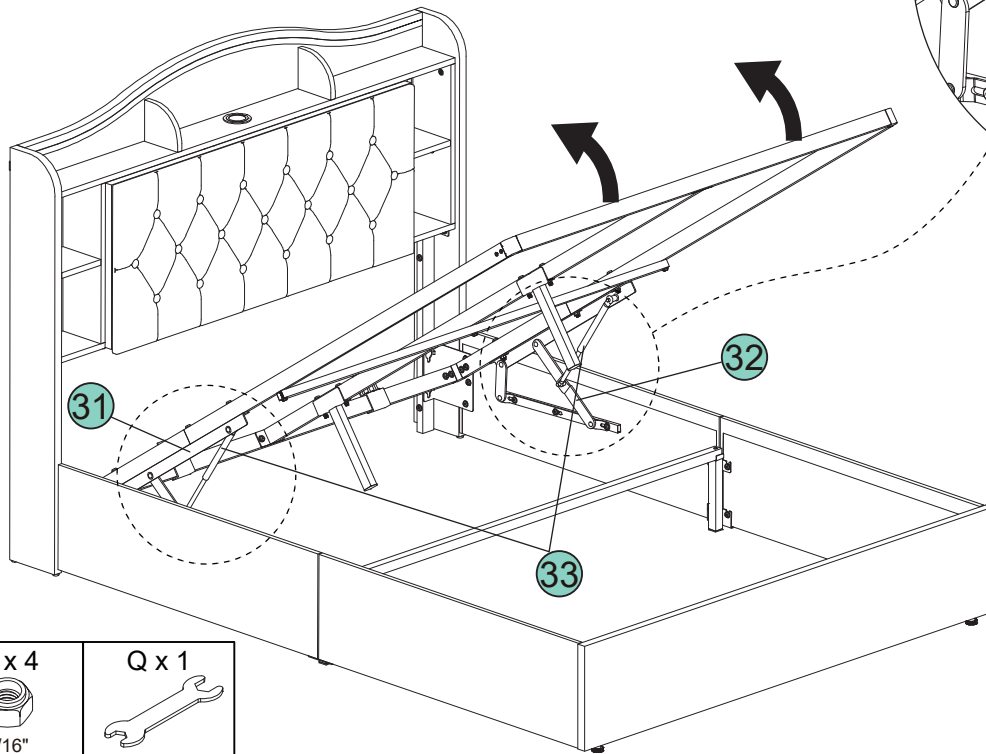
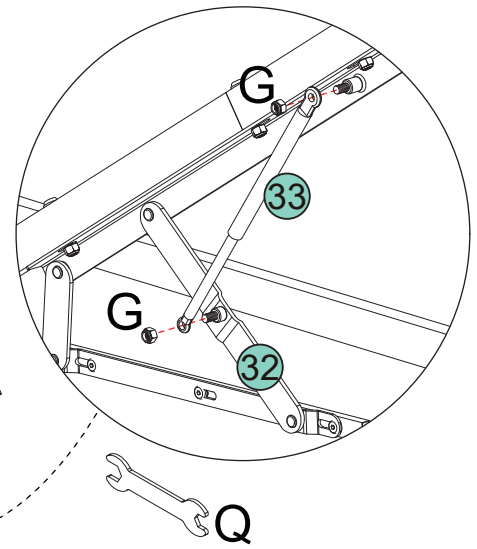
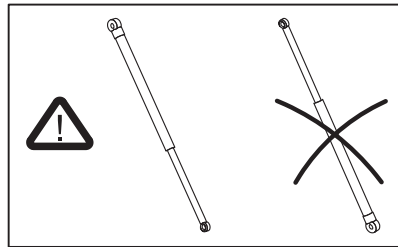

G x 4



5/16"

Q x 1

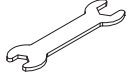

STEP 34

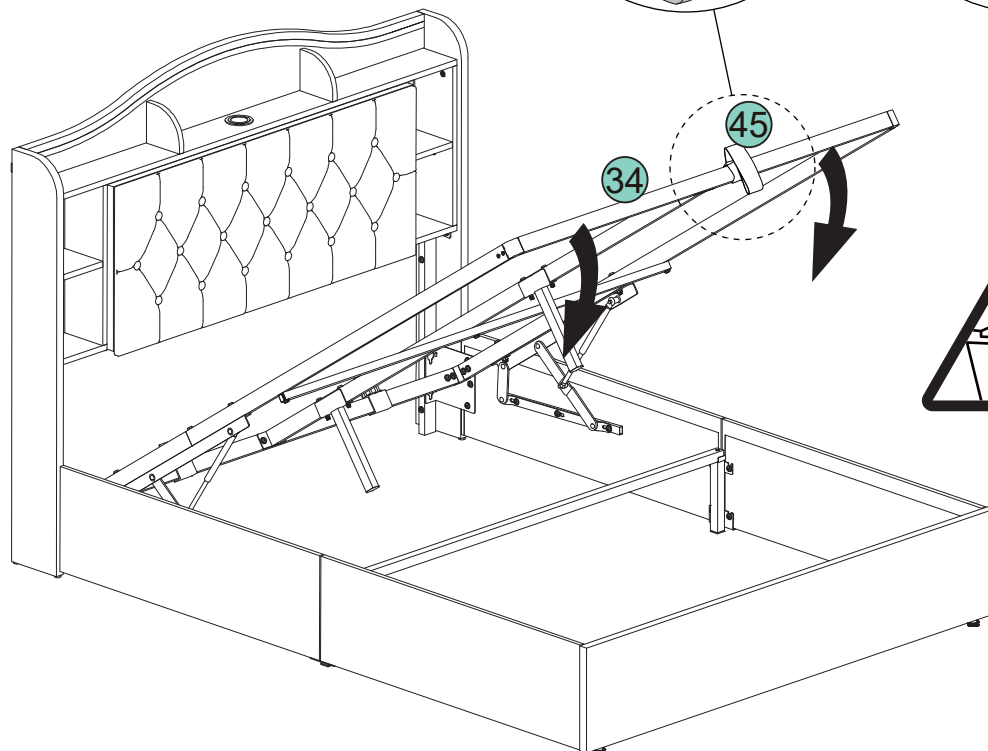
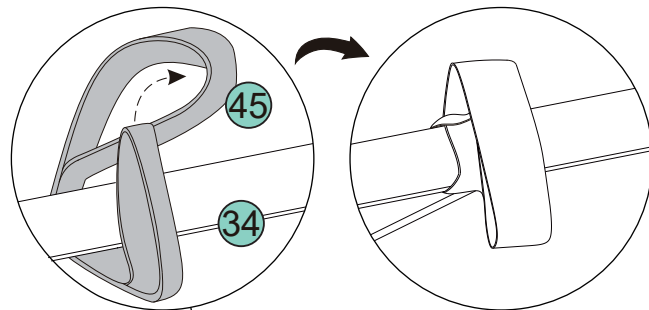

STEP 35

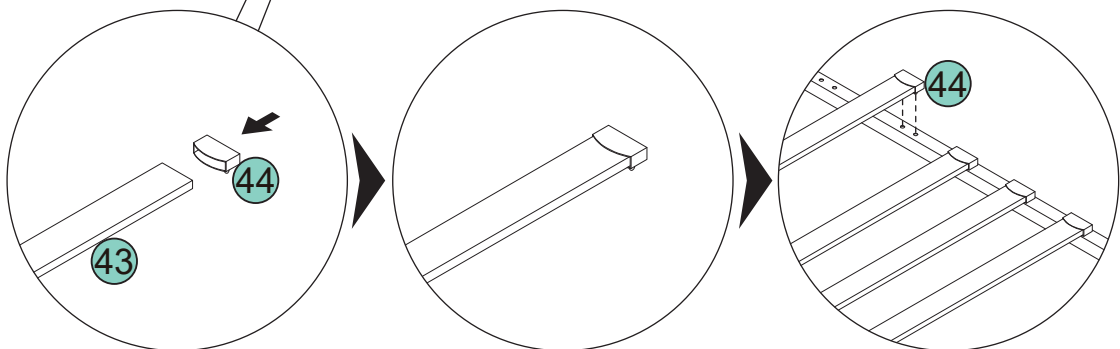
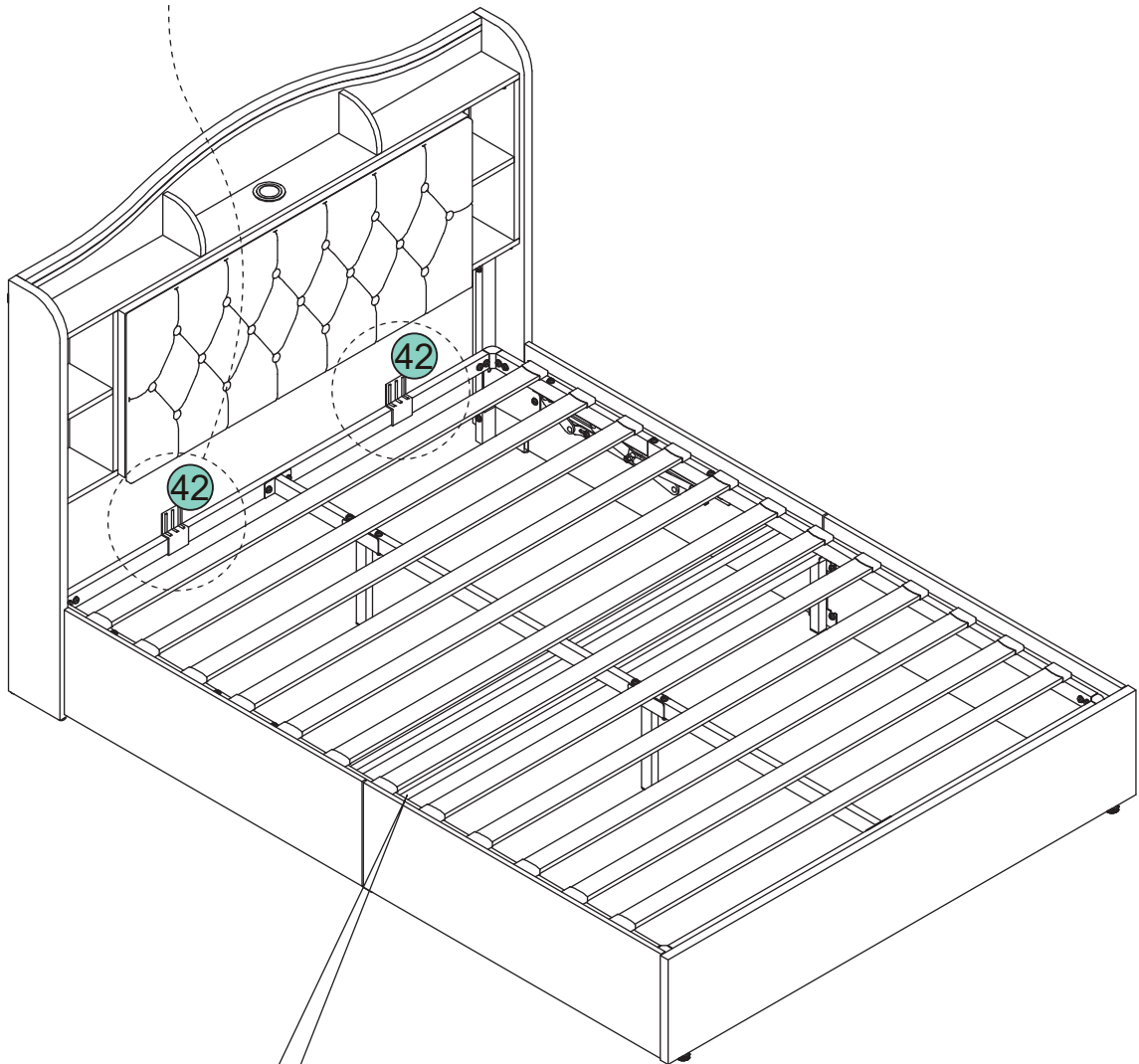
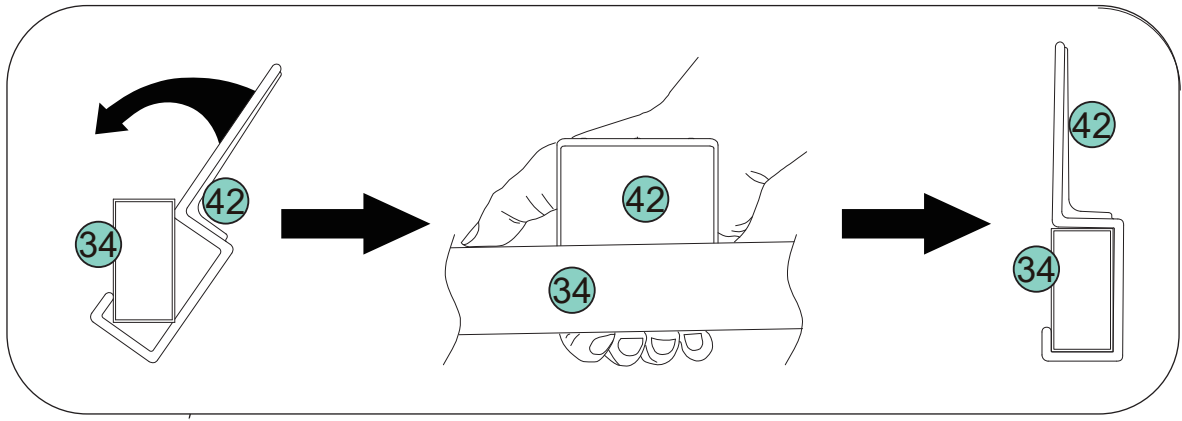

STEP 36

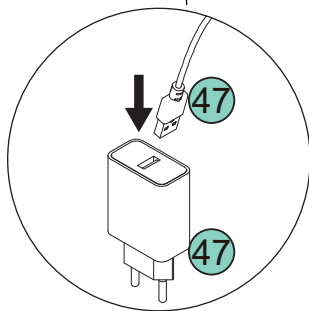
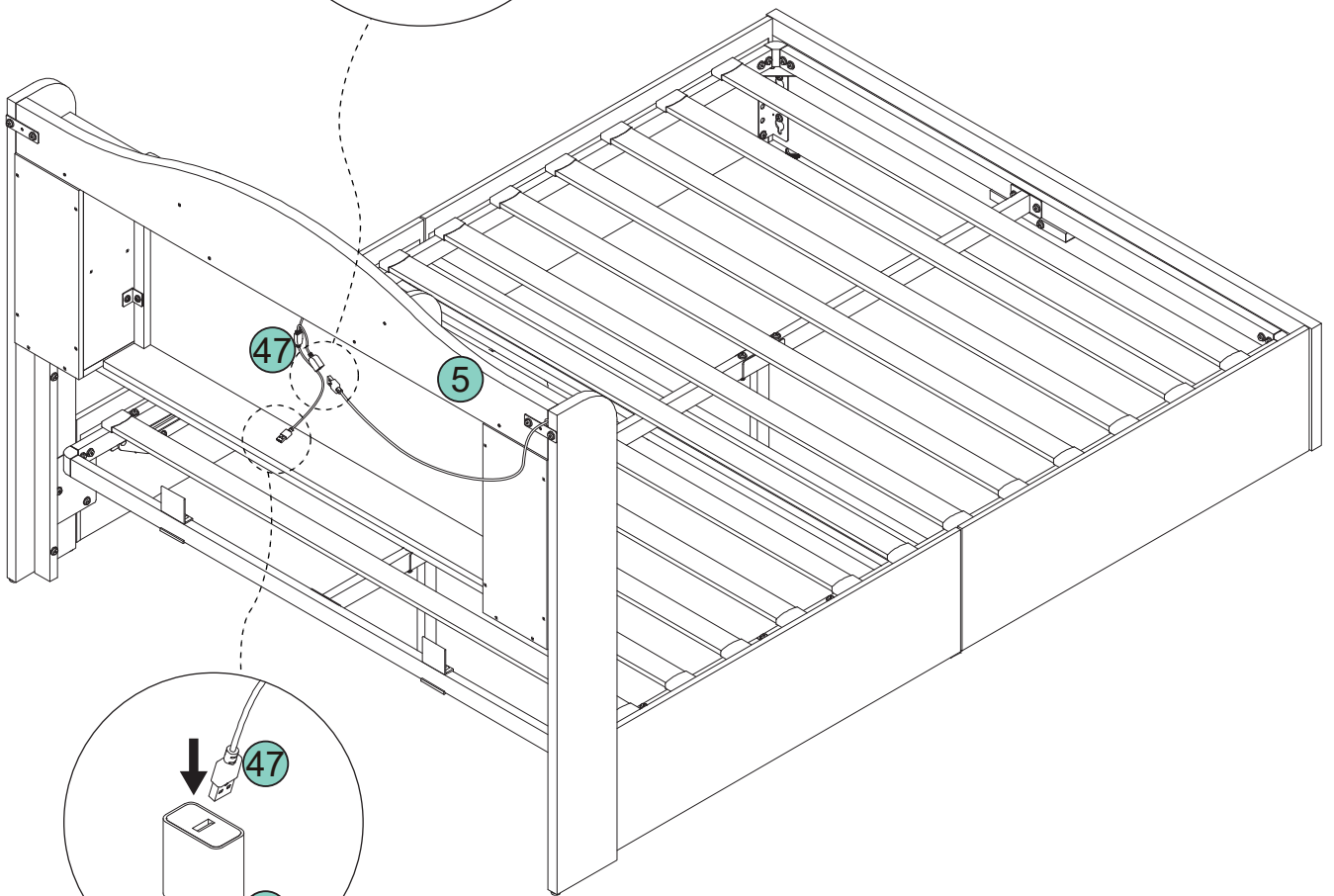
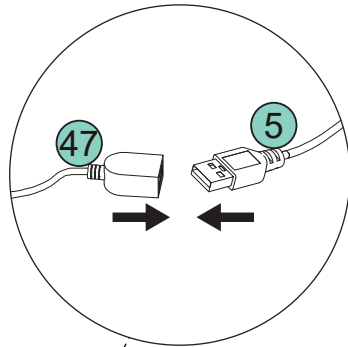
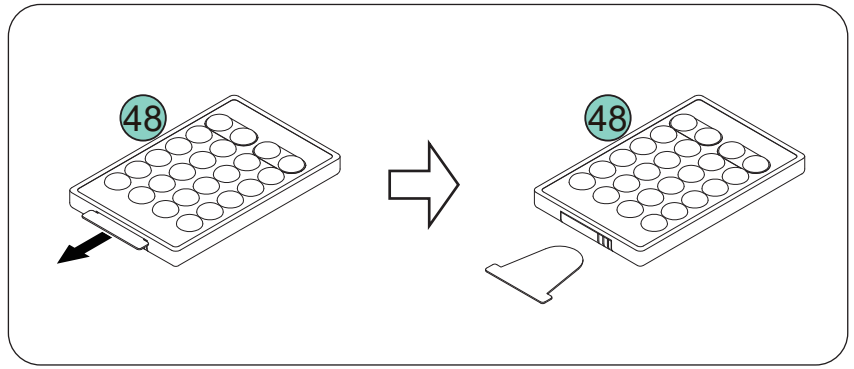

47 x 1



48 x 1

