











Assembly Instructions

Caution: You must read this before you proceed

Care & Maintenance

	<ul style="list-style-type: none">● Not for commercial use. For residential use only.
	<ul style="list-style-type: none">● Do not put hot items directly on furniture surface.
	<ul style="list-style-type: none">● Do not clean furniture with harsh cleansers or polish.
	<ul style="list-style-type: none">● Do not place furniture under direct sunlight.
	<ul style="list-style-type: none">● Do not place furniture near heating or cooling vents.
	<ul style="list-style-type: none">● Do not write on furniture without a padded barrier to protect the surface.
	<ul style="list-style-type: none">● Do not place furniture outside . For indoor use only.
	<ul style="list-style-type: none">● Stains may be removed with mild soap solution and damp cloth.
	<ul style="list-style-type: none">● Children should not climb or jump on the furniture.
	<ul style="list-style-type: none">● Dust and pick-up spills using a clean, non-colored, lint-free cloth.

QUEEN BED

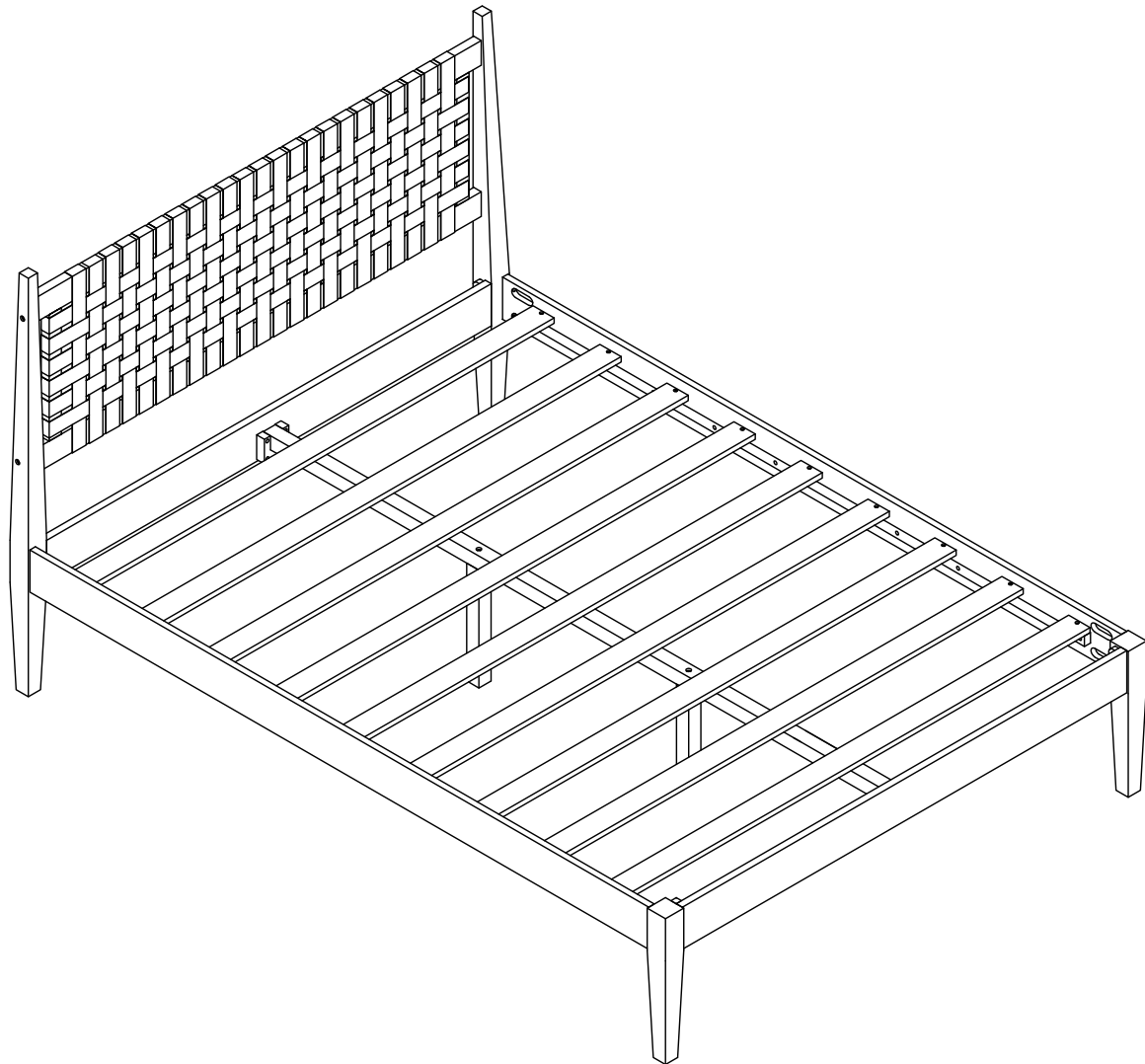
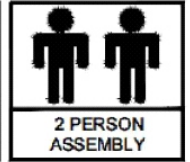
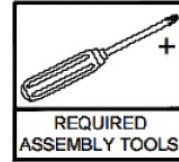

WARNING

STRANGULATION HAZARD.

NEVER place bed near windows where cords from blinds or drapes may strangle a child.
NEVER suspend strings over bed.
NEVER place items with a string, cord, or ribbon, such as hood strings or pacifier cords, around a child's neck. These items may catch on bed parts.
ALWAYS follow assembly instructions.



WARNING!

Not intended for children under the age of six. **INFANTS HAVE DIED FROM BECOMING ENTRAPPED IN BEDS.** Openings in and between bed parts can entrap the neck and head of a small child. NEVER use bed for child under the age of six.

The mattress must be appropriately sized for the bed. If the mattress is undersized, dangerous gaps can exist and a person can become entrapped or entangled in the frame and suffocate.

Note: This Bed is NOT a TOY.

Keep your child/children at bay during the assembly process.





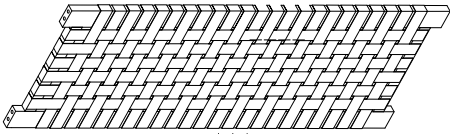
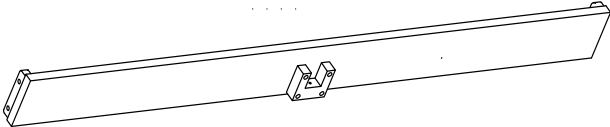
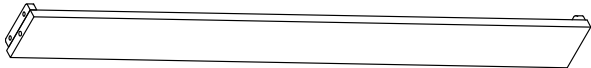
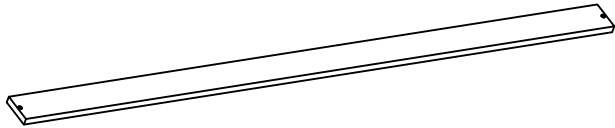

The BED is HEAVY.

To prevent injury to yourself or damage to the product a minimum of two adults are required whenever moving or lifting it.

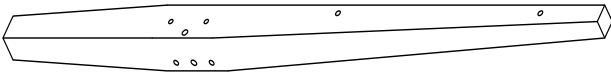



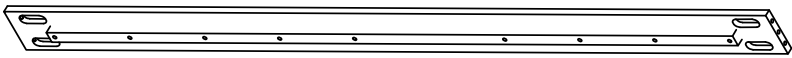

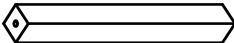
Part List BOX 1 OF 2

Label	Picture	Description	Qty
A		Headboard	1
D		Cross Panel	1
E		Footboard	1
L		Slat	9

Part List BOX 2 OF 2

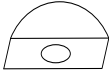
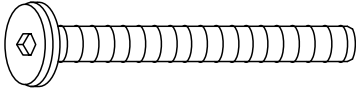
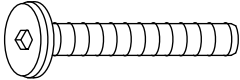
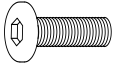
Label	Picture	Description	Qty
B		Headboard Leg-L	1
C		Headboard Leg-R	1
F		Footboard Leg -L	1
G		Footboard Leg -R	1
H		Side Panel - L	1
I		Side Panel - R	1
J		Slats Support	1
K		Center Leg	2

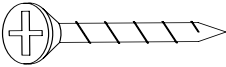
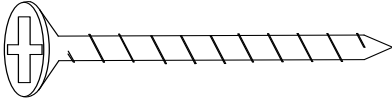
Hardware List - (BOX 1)

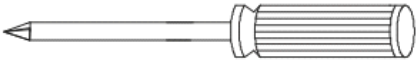
Label	Picture	Description	Qty
①		Wooden Dowel ∅ 10 x 30	12
②		T Nut ∅ 9 x 12	4
③		Half moon Nut 12 x 20	8
④		Long Bolt 1/4" x 80	4
⑤		Middle Bolt 1/4" x 60	10
⑥		Short Bolt 1/4" x 38	8
⑦		Flat washer 1/4" x 13	12
⑧		Spring washer 1/4" x 13	12
⑨		Flat screw M4 x 25 extra =4pc	22
⑩		Flat screw M4 x 40	2
⑪		Allen Wrench K4 x 80 extra =1pc	2
⑫		Screwdriver (Not provided)	1

Assembly Preparation

Before Beginning Assembly:

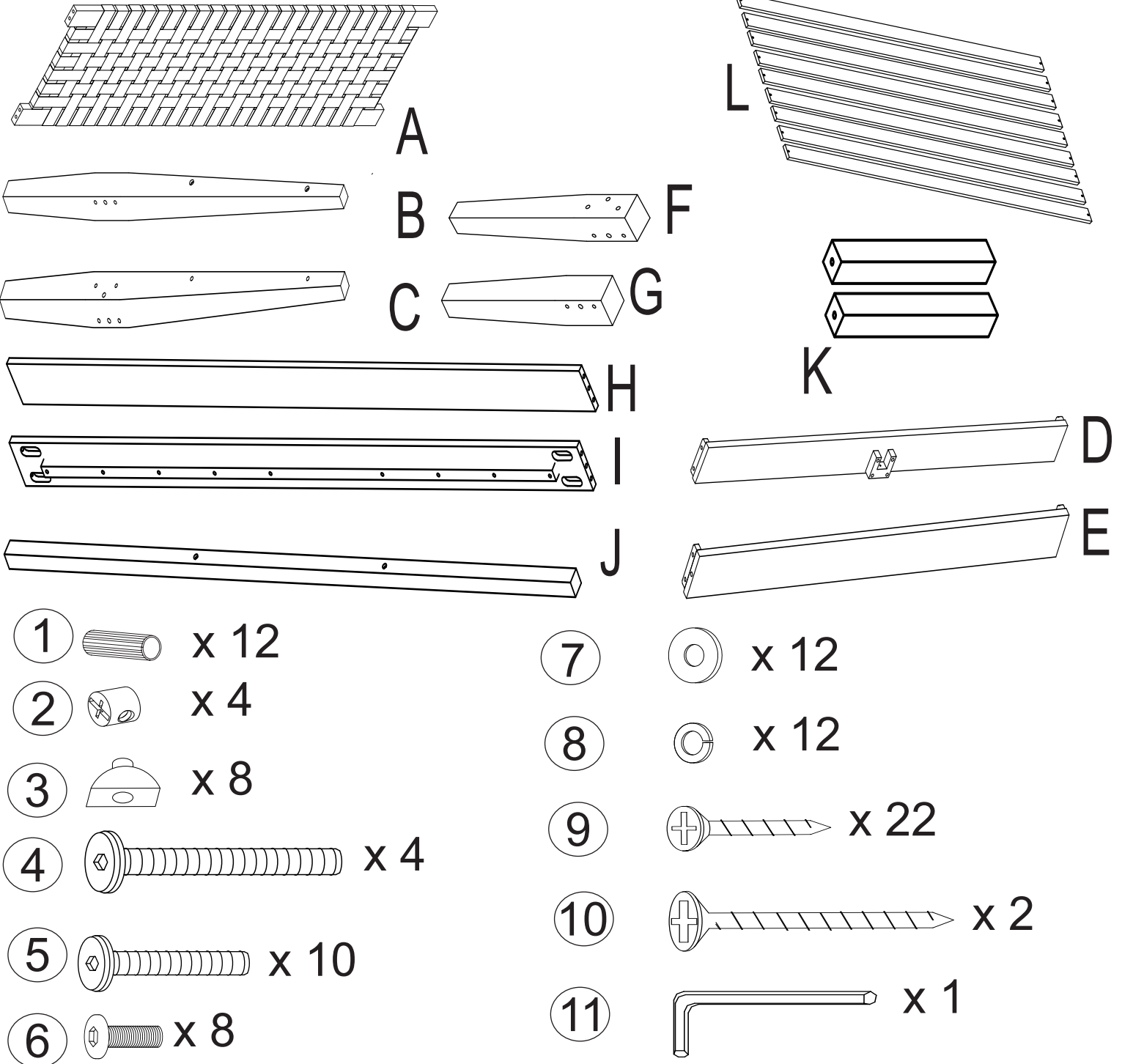

• Read instructions, cover to cover-



• Have 2 adults on hand for assembly-



• Do not assemble on flooring or carpet-



• Assemble on a clean non-marring surface (packing foam)-



• Save all packaging until finished-

Assembly Steps

Overview

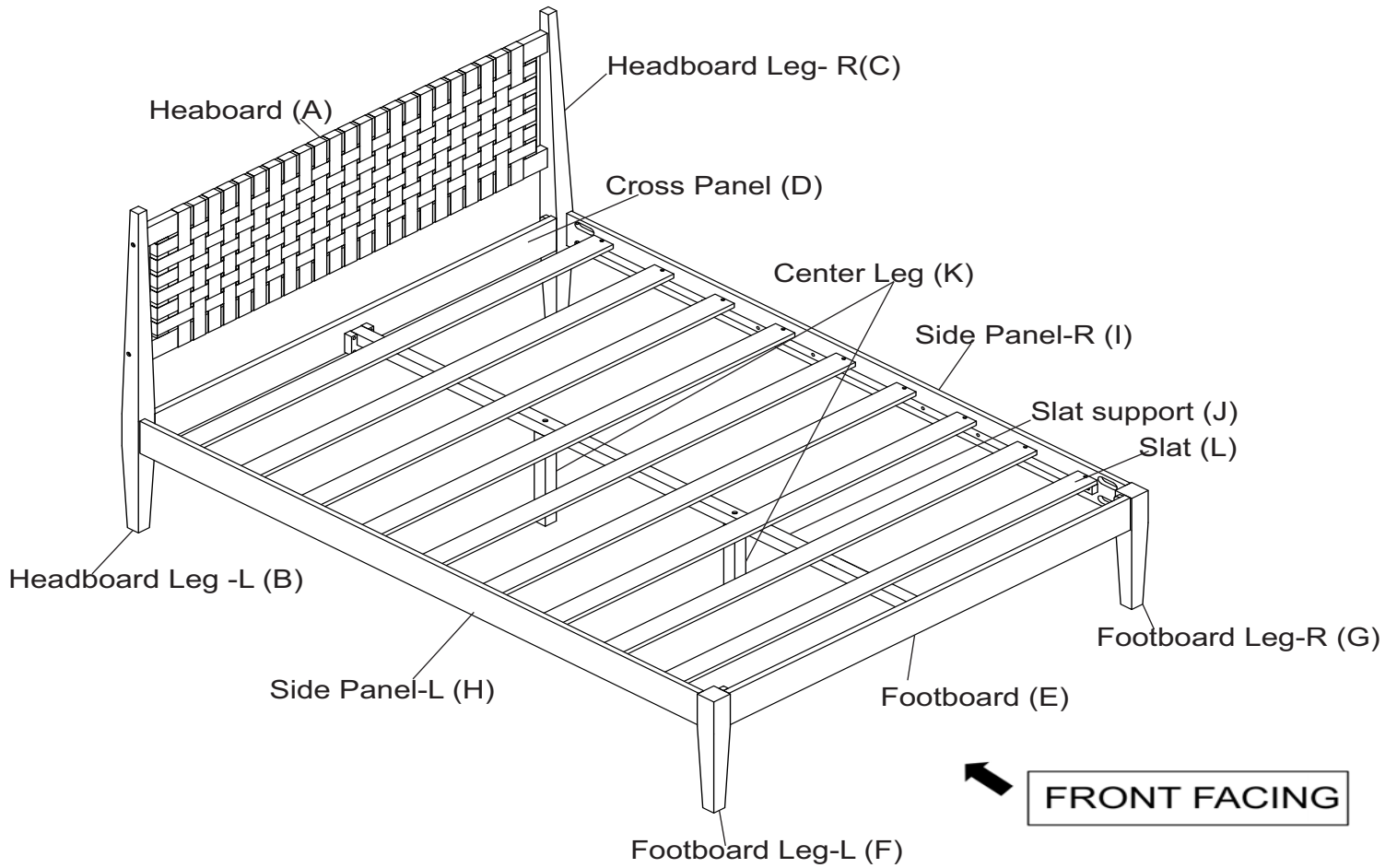

This Bed has multiple parts and may require up to 30 minutes to assemble. To give you an overview of the Bed parts, the above picture is provided to help you put the various parts into perspective. Please read through the instructions below to familiarise yourself with the parts and steps before assembly.



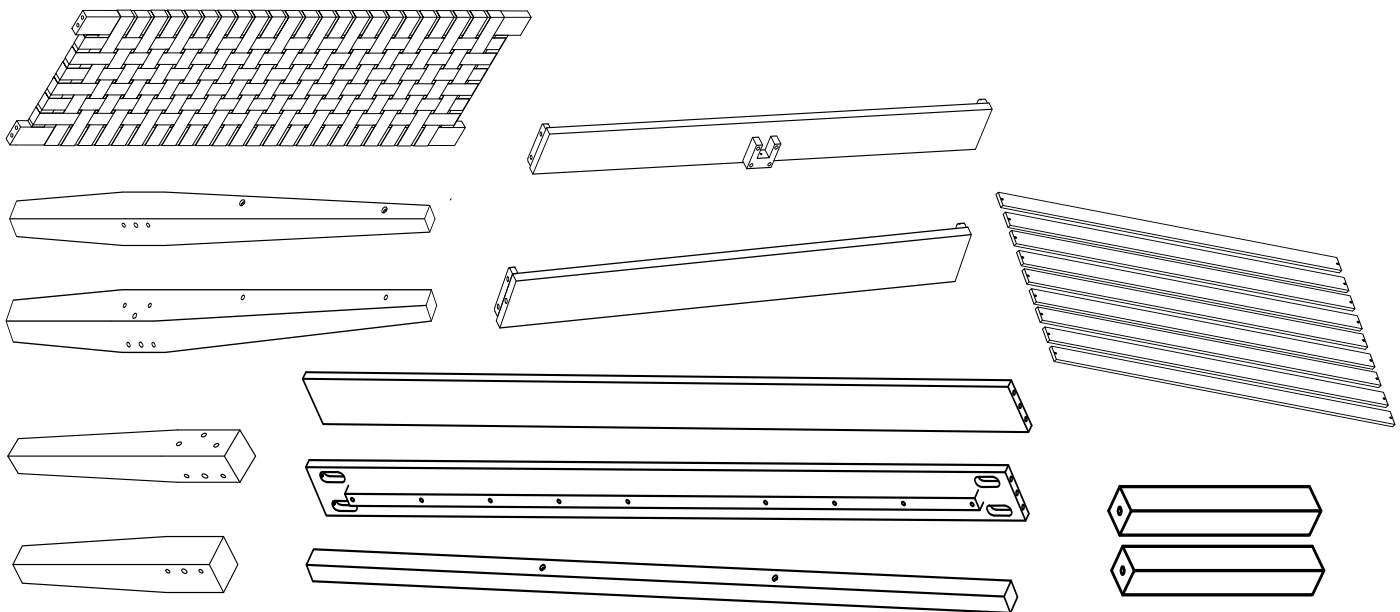



Step 1

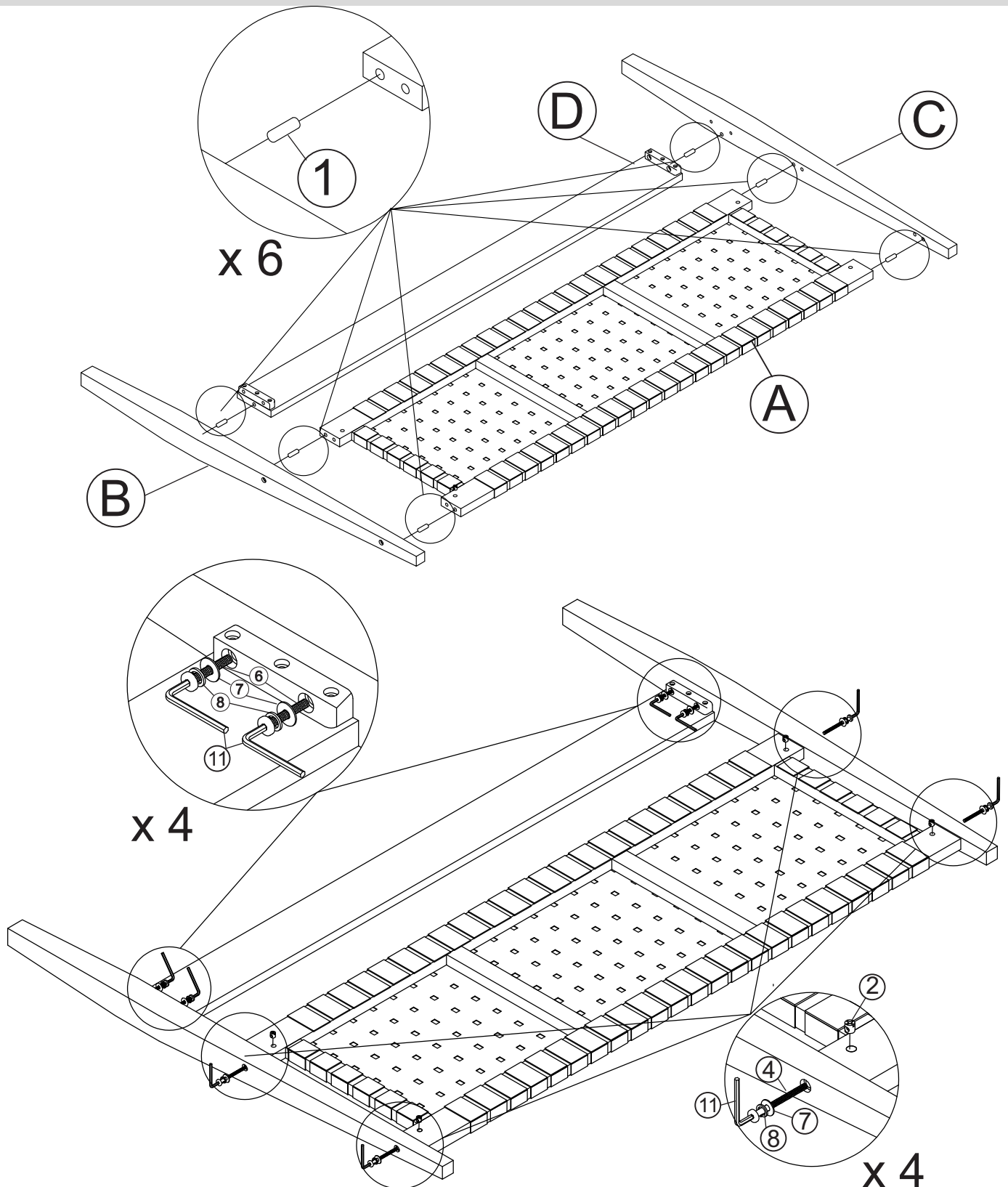

Unpack and place all parts on a clean, non-marring surface.

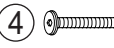
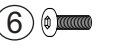
Step 2



 <p>① Wooden dowel x 6</p>	 <p>② T nut x 4</p>	 <p>④ Long Bolt x 4</p>	 <p>⑥ Short Bolt x 4</p>	 <p>⑦ Flat washer x 8</p>	 <p>⑧ Spring washer x 8</p>	 <p>⑪ Allen Key x 1</p>
---	--	--	---	--	--	--

Align the mounting position of Headboard (A) ,Cross Panel (D) and two Headboard Legs (B) & (C) with wooden dowel (①).

Attach the Headboard Legs (B) and (C) to Headboard (A) by using a Long Bolt (④),Spring Washers (⑧) and Flat Washers (⑦)with Allen Wrench(⑪), Attach the Headboard Legs (B) and (C) to Cross Panel (D) by using a short Bolt (⑥),Spring Washers (⑧) and Flat Washers (⑦)with Allen Wrench(⑪) .

Step 3

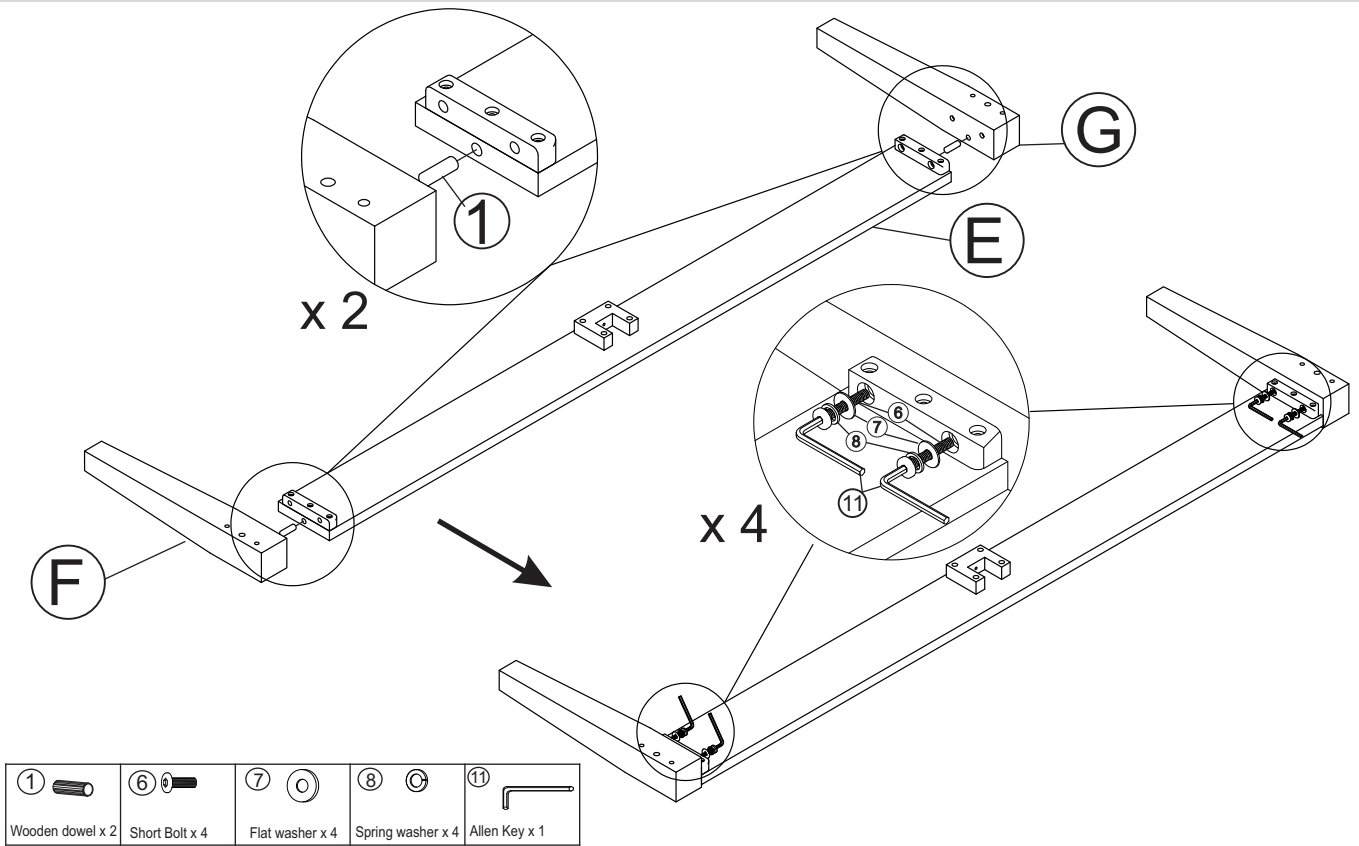

Align the the mounting position of the Footboard (E) and two Footboard Legs (F) & (G) with wooden dowel (1). Attach two Footboard Legs (F) & (G) to Footboard (E) by using a short Bolt (6), Spring Washers (8) and Flat Washers (7) with Allen Wrench (11).

Step 4

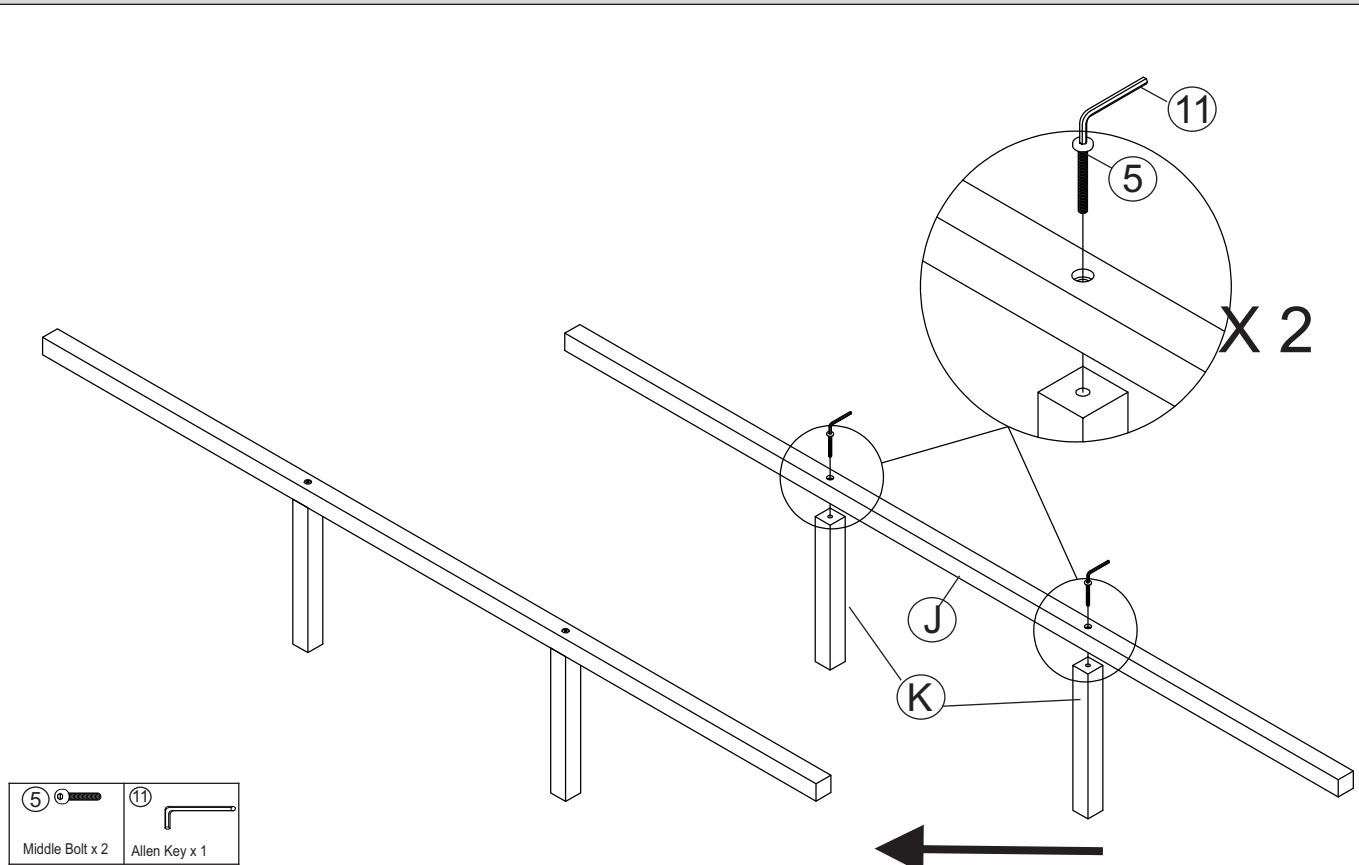

Attach the Center Leg (K) to the Slat Support (J) by Middle Bolt (5) with Allen Wrench (11).

Step 5

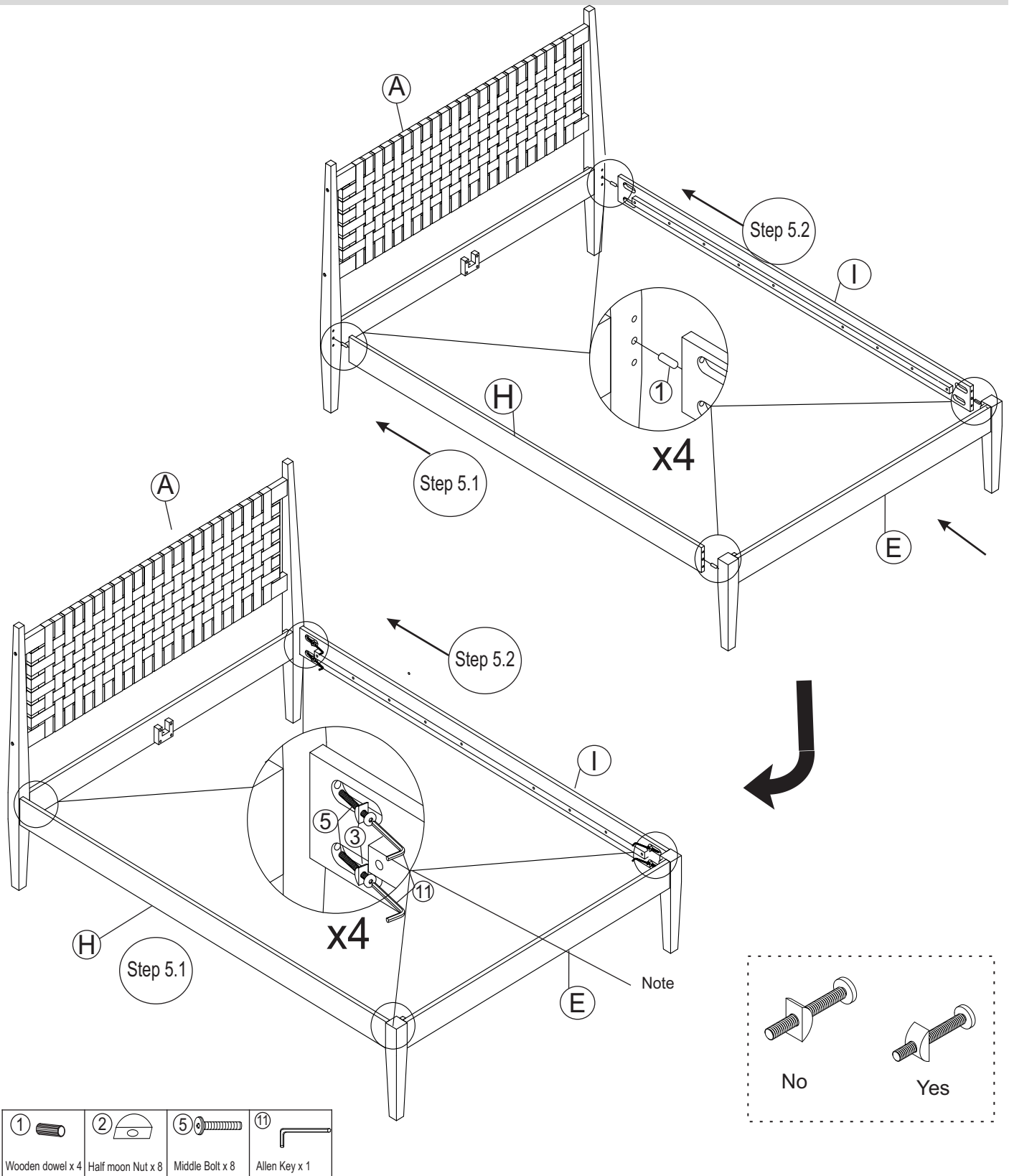

With the help from you partner, stand the assembled headboard(A) as shown in picture above.

5.1 Align the mounting position of Side Panel (H), the assembled headboard (A) and Footboard (E) with Wooden dowel (①), attach the Side Panel (H) to the assembled headboard (A) and Footboard (E) by using Bolts (⑤), Half moon nut (③) with Allen Wrench (⑪).

5.2 Repeat the same step to attach Side Panel (I) to the assembled headboard (A) and Footboard (E).

DO NOT FULLY TIGHTEN BOLTS.

Step 6

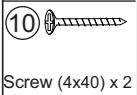
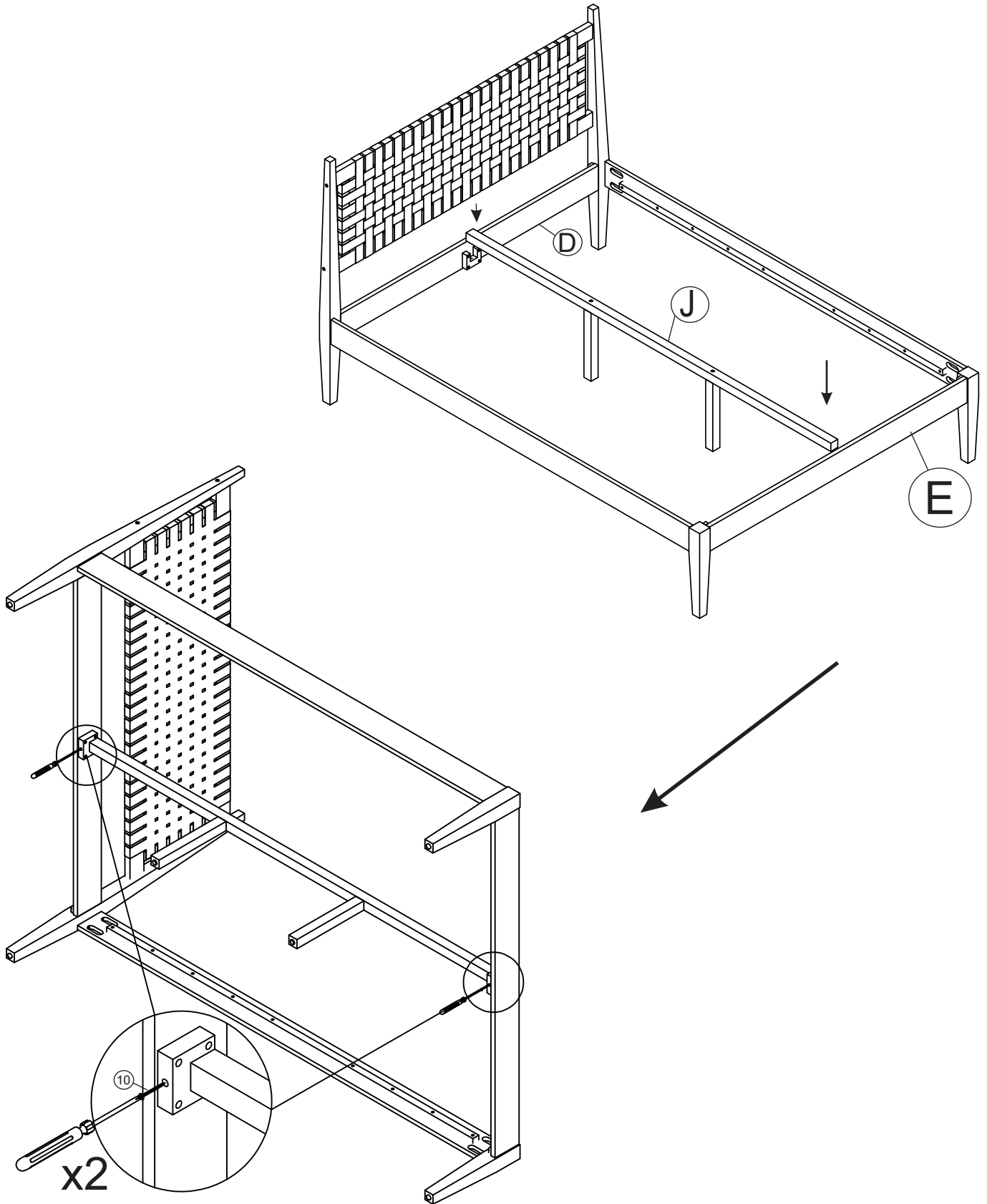

Attach the Slat support (J) to the Cross Panel (D) and Footboard (E) by using Screw (⑩) and Screwdriver (Not Provided).

Step 7

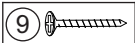
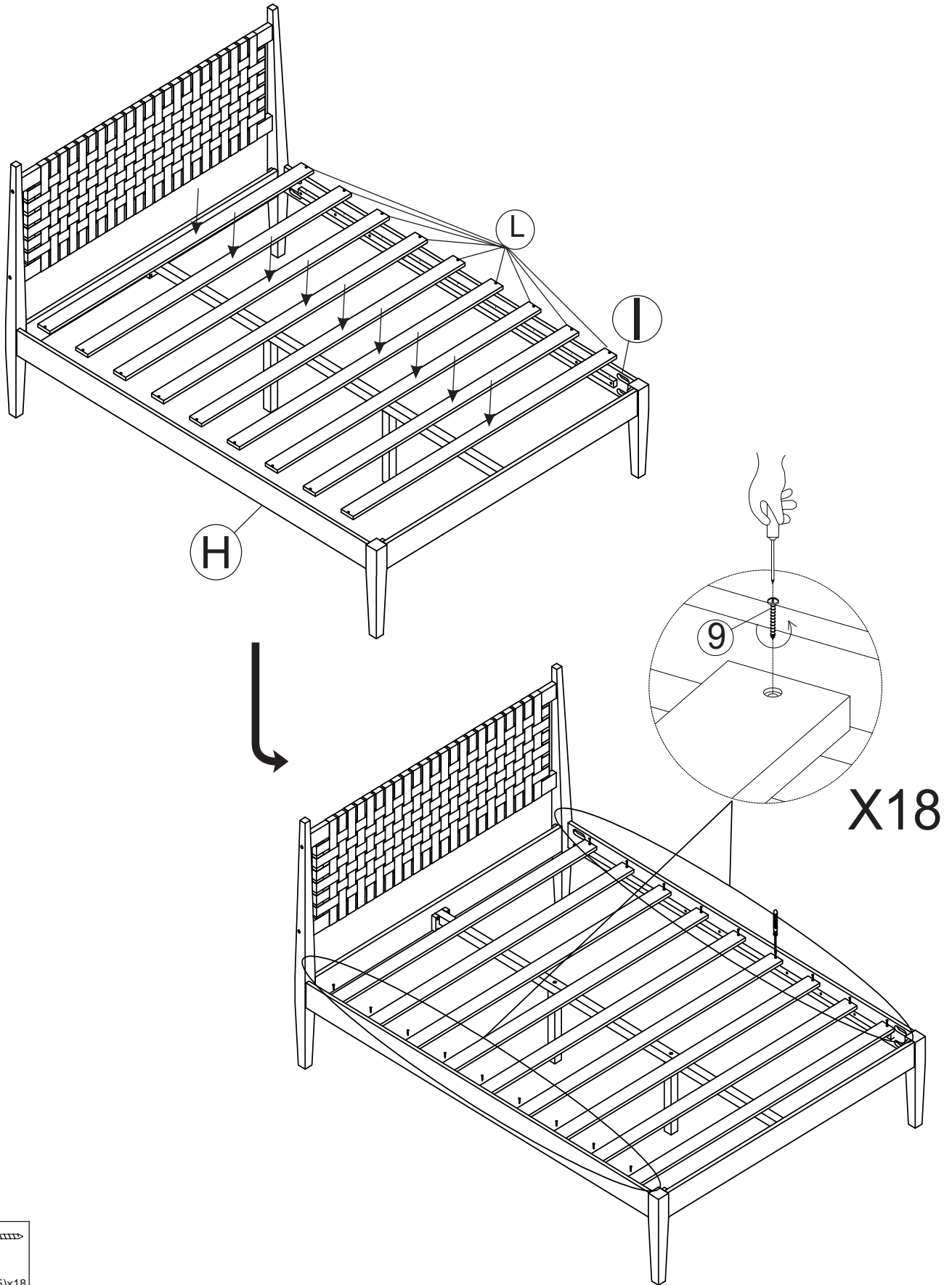

Screw (4x25)x18

And now for the final step !

Attach all slats (L) to the rail on Side Panel (H) & Side Panel (I) by using Screws (9) and Screwdriver (Not Provided).

Step 8

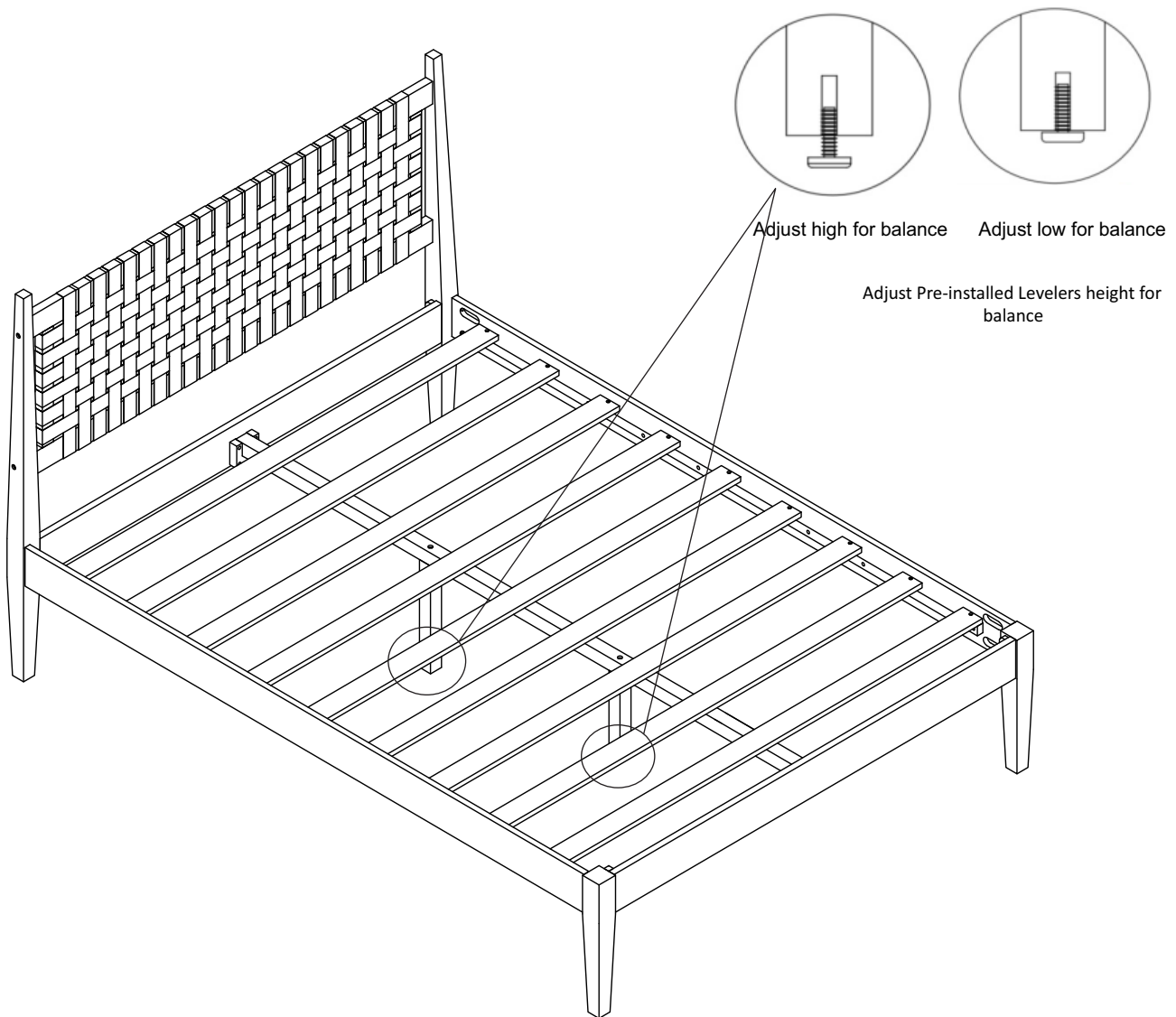

- Place the Bed on a **LEVEL SURFACE**.
- In a sequential manner, gradually tighten all Bolts until evenly secured.
- **When tightening these bolts, tighten sequentially. DO NOT tighten any bolt fully and then towards the next one. This would cause the frame to warp.**
- **Inspect the Bed and make sure all parts are adequately connected.**
- With assistance from your adult partner, adjust the Levelers to desired height to avoid wobbles.
- To adjust the Levelers, get assistance from an adult partner to lift/ lean and hold the Bed while you are working.
- Your Bed is ready for use.
- **This Bed can only be used on a flat, level surface.**