

ASSEMBLY INSTRUCTION

SKU CODE: (WF302293-WF302294)

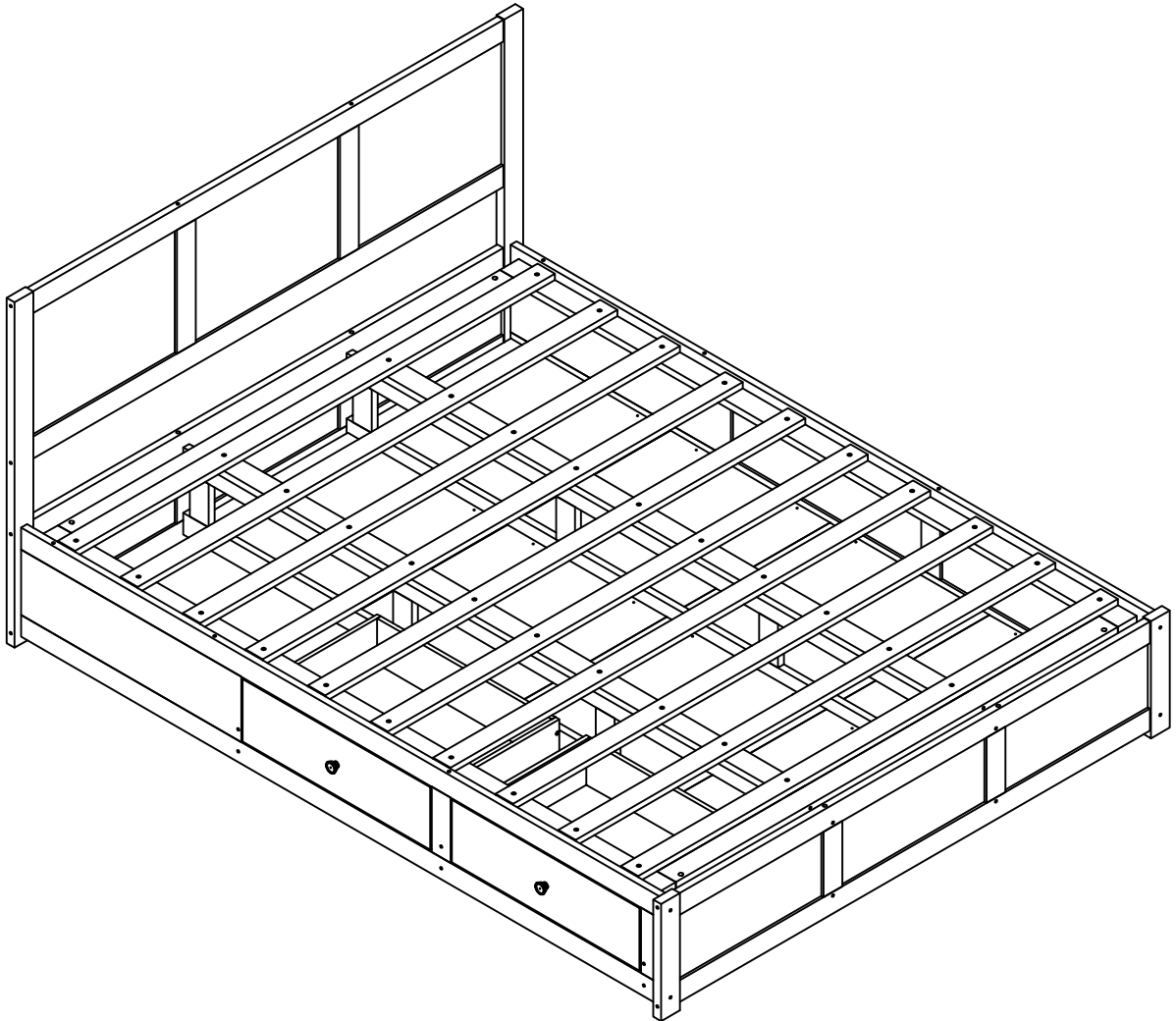





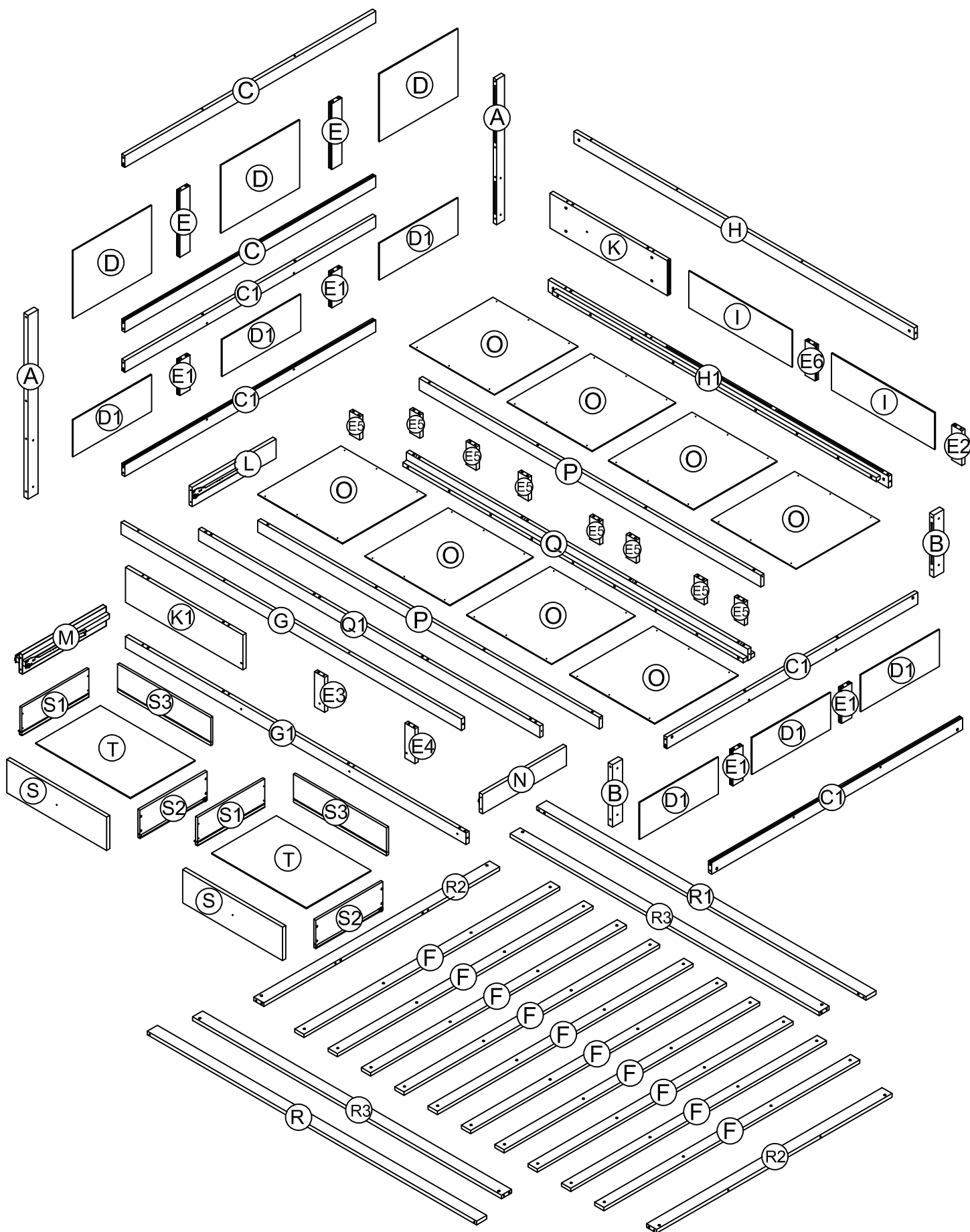

! SAFETY WARNINGS !

1. This bed is designed for use QUEEN Mattress 80 inch Long 60 inch Wide.
2. Always use the recommended size mattresses or mattress supports, or both, to help prevent the likelihood of entrapment or falls.
3. Do not allow horseplay on or under the bed and prohibit jumping on the bed
4. Do not use substitute parts. Contact the manufacturer or dealer for replacement parts.
5. Keep these instructions for future reference

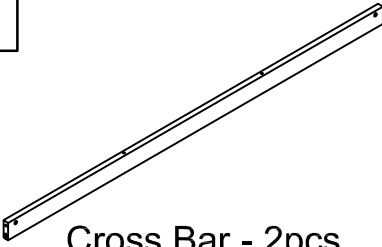
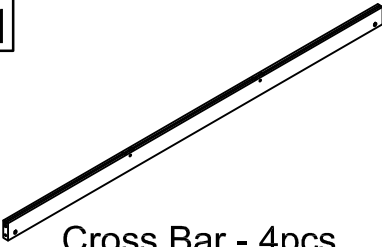
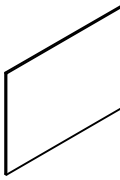
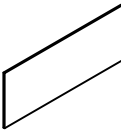



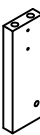

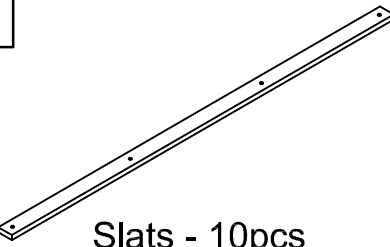
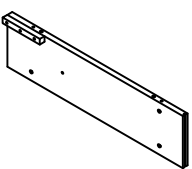
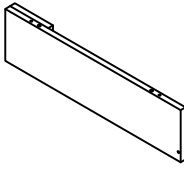
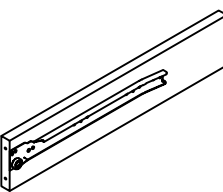
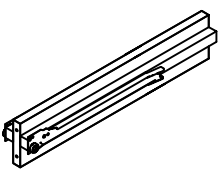
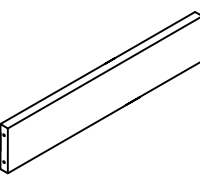
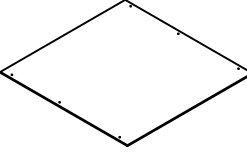
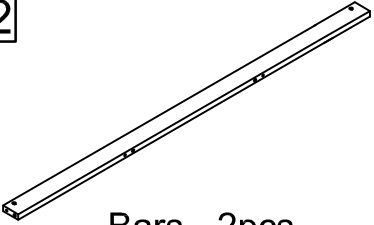
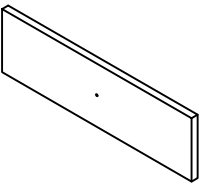
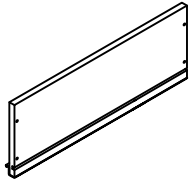
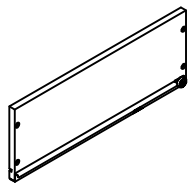
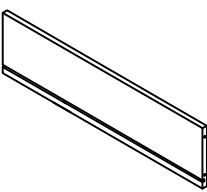
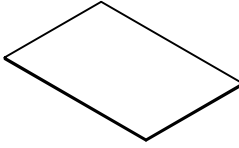
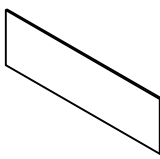

ASSEMBLY INSTRUCTION

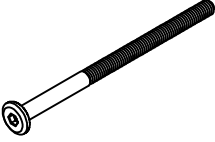
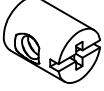
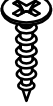

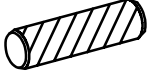
Part List (WF302293)

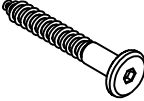
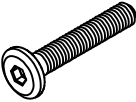
<p>C</p>  <p>Cross Bar - 2pcs</p>	<p>C1</p>  <p>Cross Bar - 4pcs</p>	<p>D</p>  <p>Head Panels - 3pcs</p>
<p>D1</p>  <p>Back Panels - 6pcs</p>	<p>E1</p>  <p>Vertical Bar - 4pcs</p>	<p>E2</p>  <p>Vertical Bar - 1pcs</p>
<p>E3</p>  <p>Vertical Bar - 1pcs</p>	<p>E4</p>  <p>Vertical Bar - 1pcs</p>	<p>E5</p>  <p>Vertical Bar - 8pcs</p>
<p>E6</p>  <p>Vertical Bar - 1pcs</p>	<p>F</p>  <p>Slats - 10pcs</p>	<p>K</p>  <p>Sides Right - 1pcs</p>
<p>K1</p>  <p>Sides Left - 1pcs</p>	<p>L</p>  <p>Panels - 1pcs</p>	<p>M</p>  <p>Panels - 1pcs</p>
<p>N</p>  <p>Panels - 1pcs</p>	<p>O</p>  <p>Panels - 8pcs</p>	<p>R2</p>  <p>Bars - 2pcs</p>
<p>S</p>  <p>Draws - Front Panels - 2pcs</p>	<p>S1</p>  <p>Draws - Sides Panels - 2pcs</p>	<p>S2</p>  <p>Draws - Sides Panels - 2pcs</p>
<p>S3</p>  <p>Draws - Back Panels - 2pcs</p>	<p>T</p>  <p>Draws - Panels - 2pcs</p>	<p>I</p>  <p>Sides Panels - 2pcs</p>

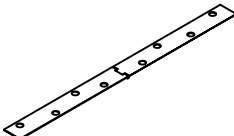
Hardware List

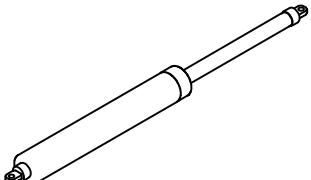
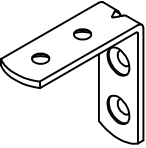
<p>1</p>  <p>Ø1/4" x 60mm Hex-Head bolts 8pcs</p>	<p>2</p>  <p>Ø1/4" x 100mm Hex-Head bolts 44pcs</p>	<p>3</p>  <p>Ø11.5 x 15 mm Horizontal-Hole bolts 52pcs</p>
<p>4</p>  <p>M4 x 20 mm Wood Screws 72pcs</p>	<p>5</p>  <p>M4 x 30 mm Wood Screws 56pcs</p>	<p>6</p>  <p>M4 x 50 mm Wood Screws 16pcs</p>
<p>7</p>  <p>Ø10 x 30 mm Wood Dowel 80pcs</p>	<p>8</p>  <p>M4 x 35 mm Bulong 2pcs</p>	<p>9</p>  <p>Wood Knob 2pcs</p>
<p>10</p>  <p>Ø1/4" x 50 mm Wood Screws 20pcs</p>	<p>11</p>  <p>Ø1/4" x 30mm Hex-Head bolts 4pcs</p>	<p>12</p>  <p>Disk Washer 2pcs</p>
<p>13</p>  <p>Hinge Long 2pcs</p>	<p>14</p>  <p>Allen Key 1pcs</p>	<p>15</p>  <p>Piston 2pcs</p>
<p>16</p>  <p>Steel Bracket 4pcs</p>		

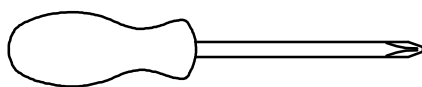

Assembly Tools Required (Not Included)

Part List (WF302294)

A



Headboard - 2pcs

B



Footboard - 2pcs

E



Vertical Bar - 2pcs

G



Sides Bar - 1pcs

G1

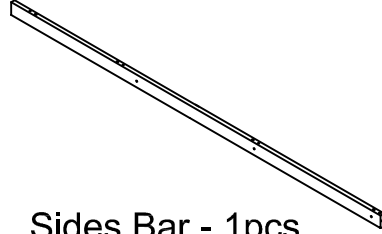

Sides Bar - 1pcs

H



Sides Bar - 1pcs

H1



Sides Bar - 1pcs

P



Sides Bar - 2pcs

Q



Sides Bar - 1 pcs

Q1



Sides Bar - 1pcs

R



Bars Left - 1pcs

R1

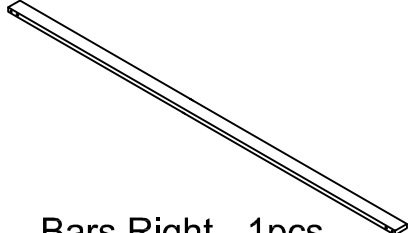

Bars Right - 1pcs

R3

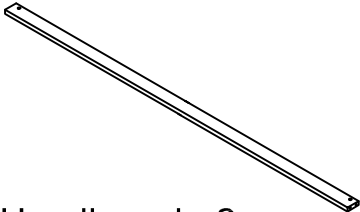

Headboard - 2pcs

STEP 1: Following below illustration.

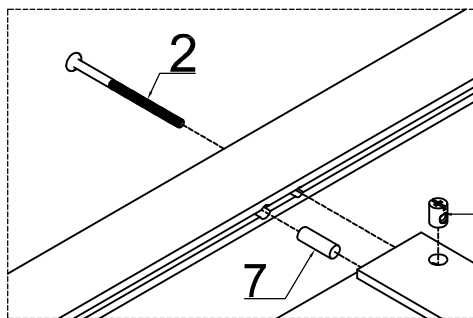

2		3		7	
4pcs		4pcs		4pcs	

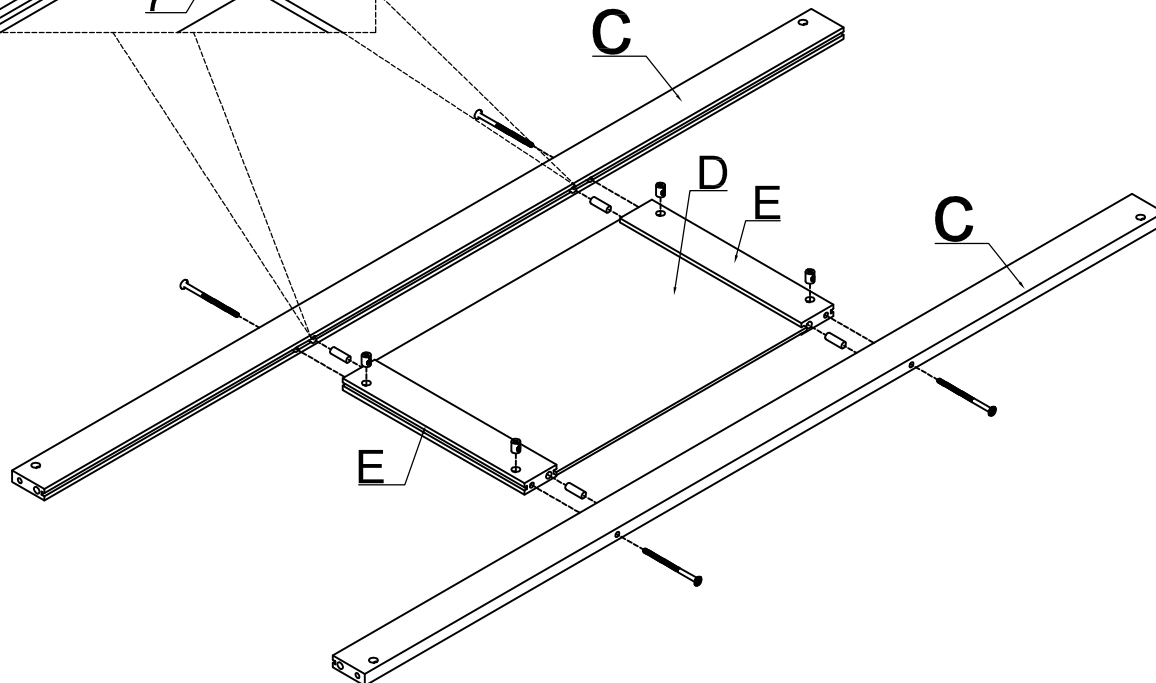

STEP 1-1: Following below illustration.

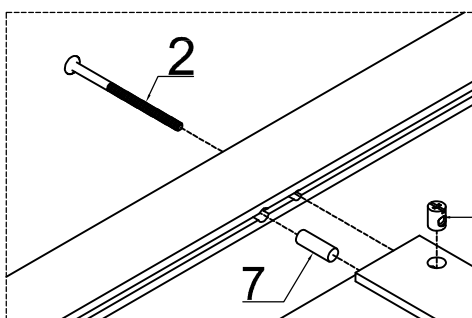

2		3		7	
4pcs		4pcs		4pcs	

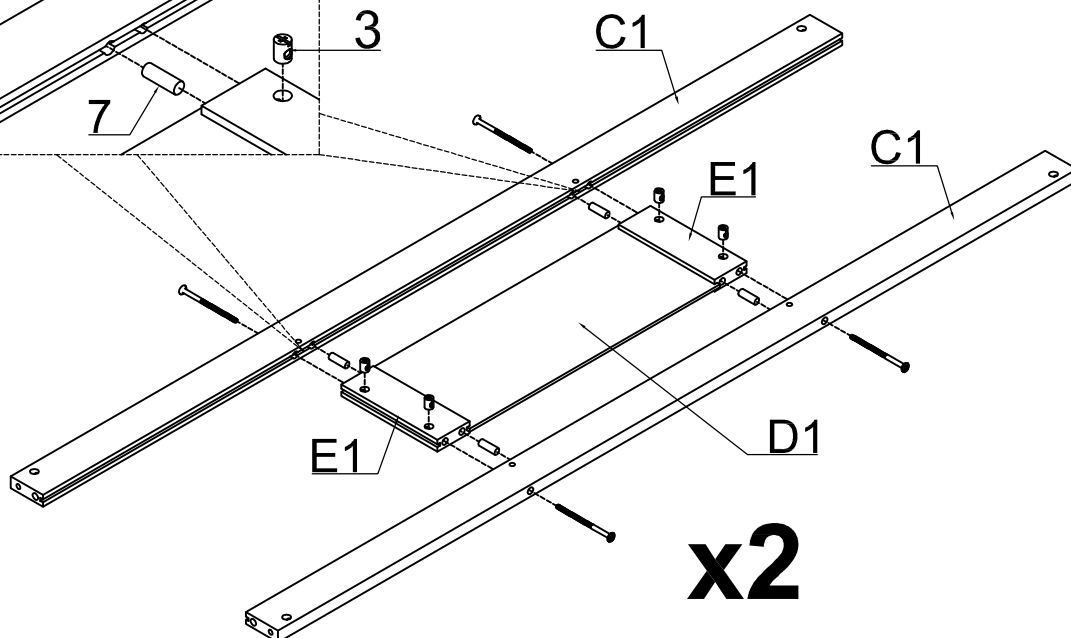

STEP 2: Following below illustration.

2	3	7
8pcs	8pcs	8pcs

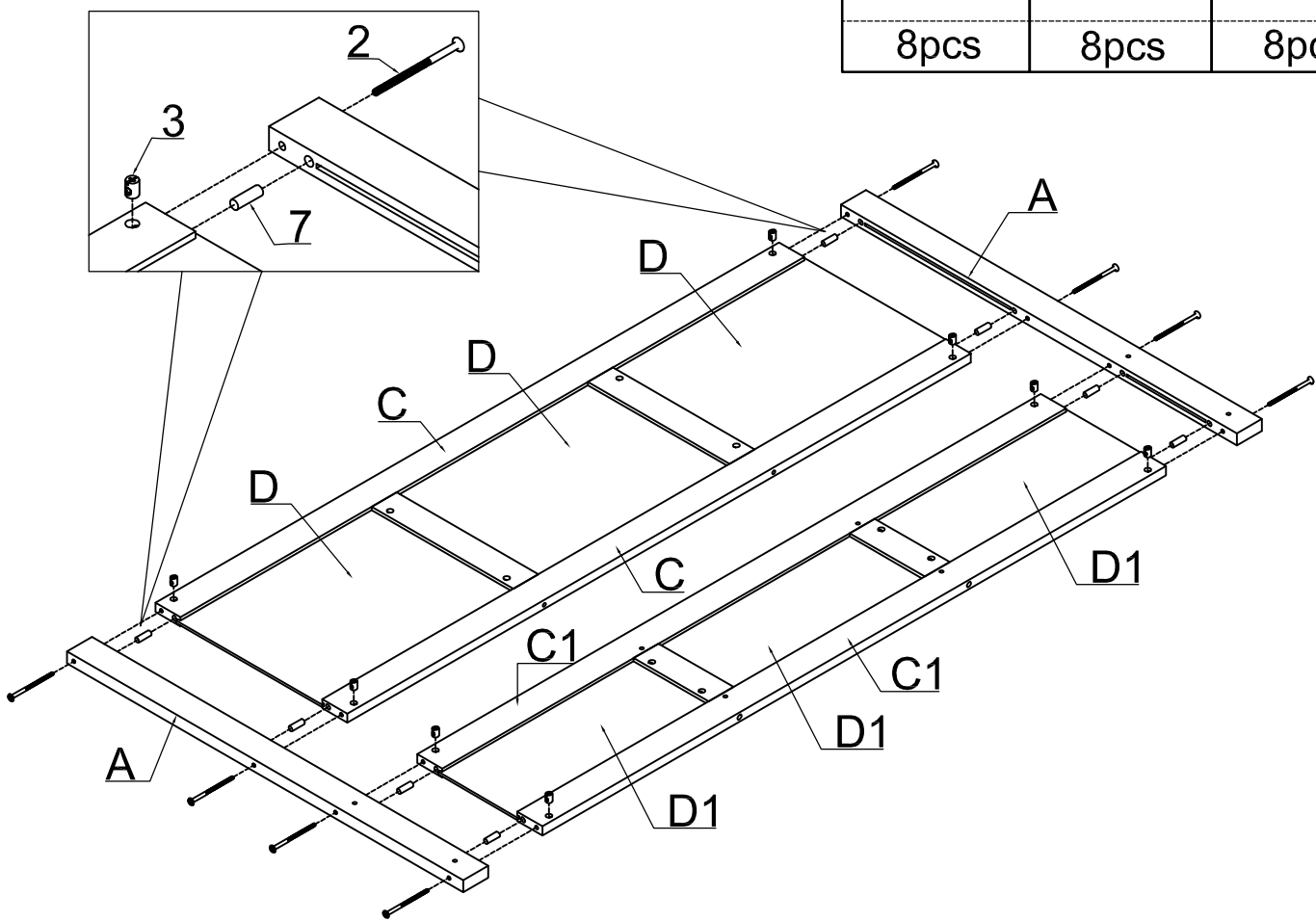

STEP 2-1: Following below illustration.

2	3	7
4pcs	4pcs	4pcs

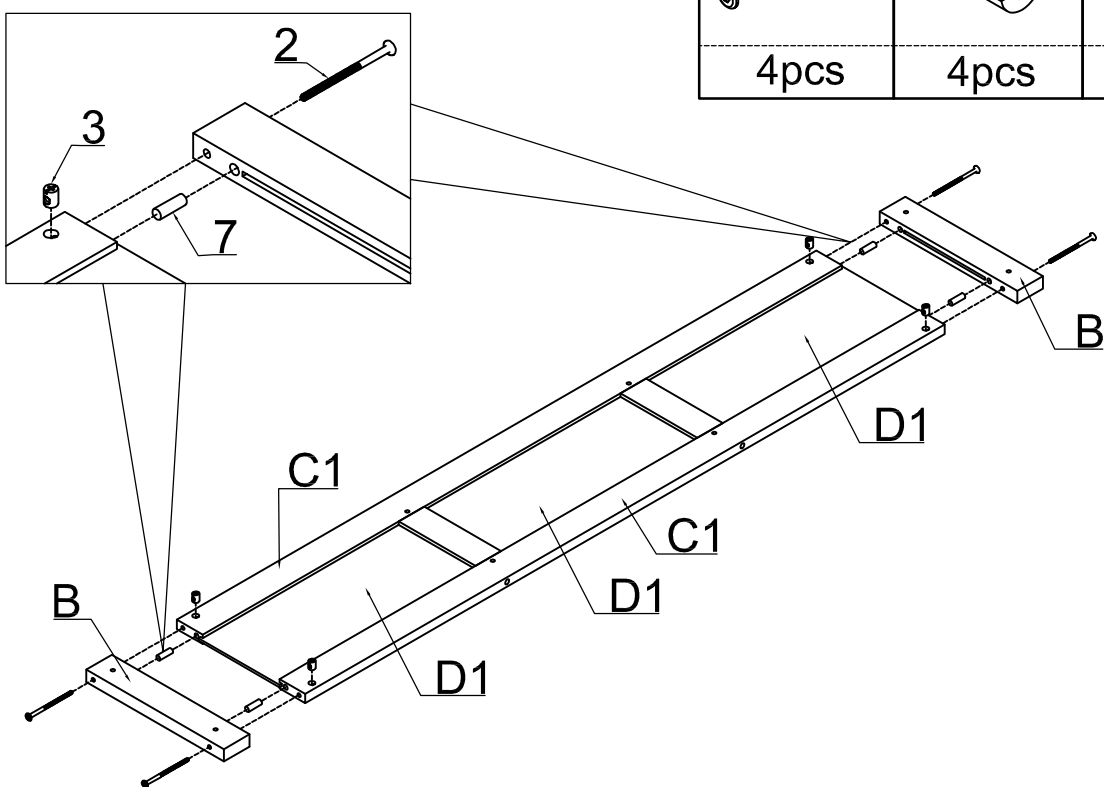

STEP 3: Following below illustration.

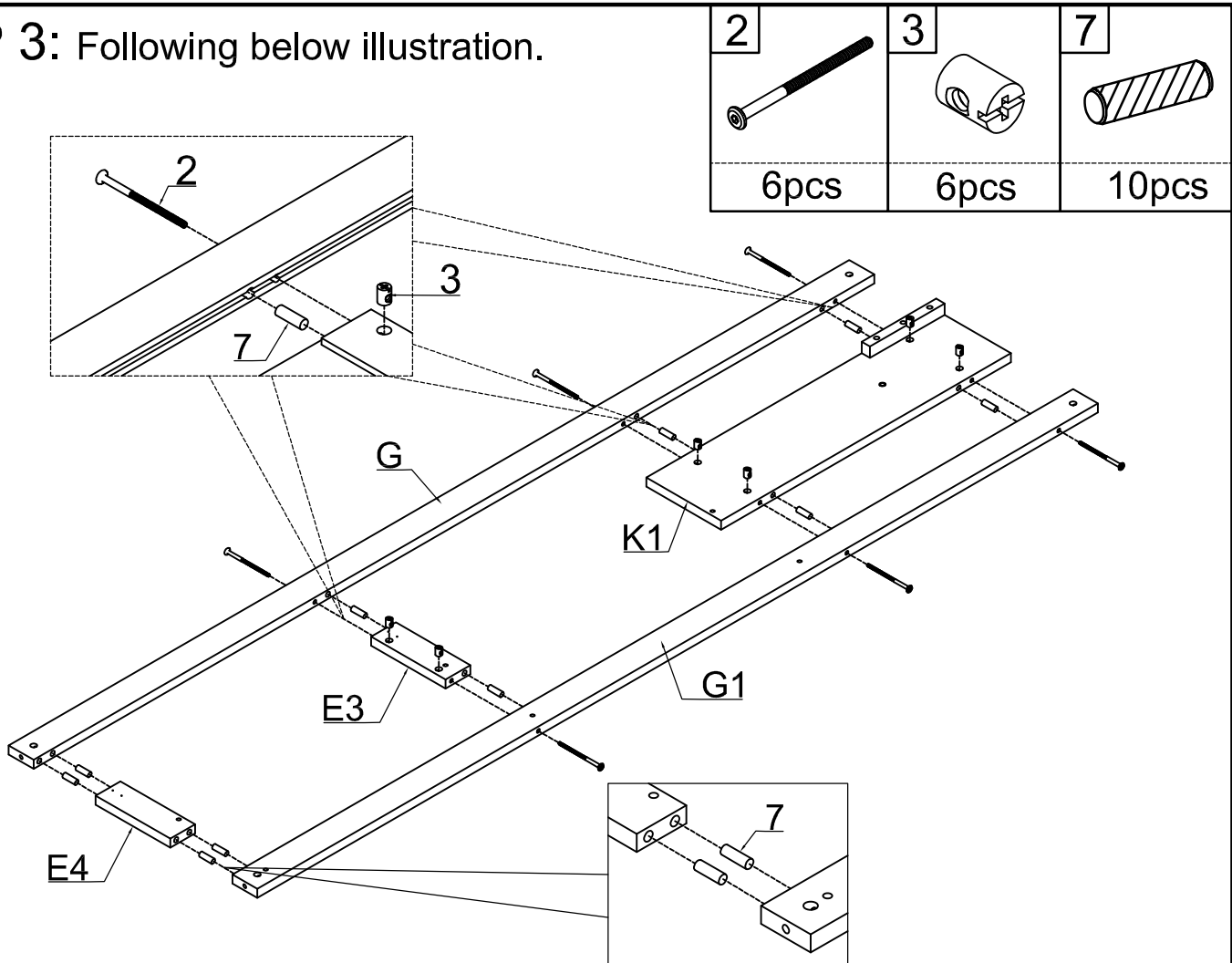

STEP 3-1: Following below illustration.

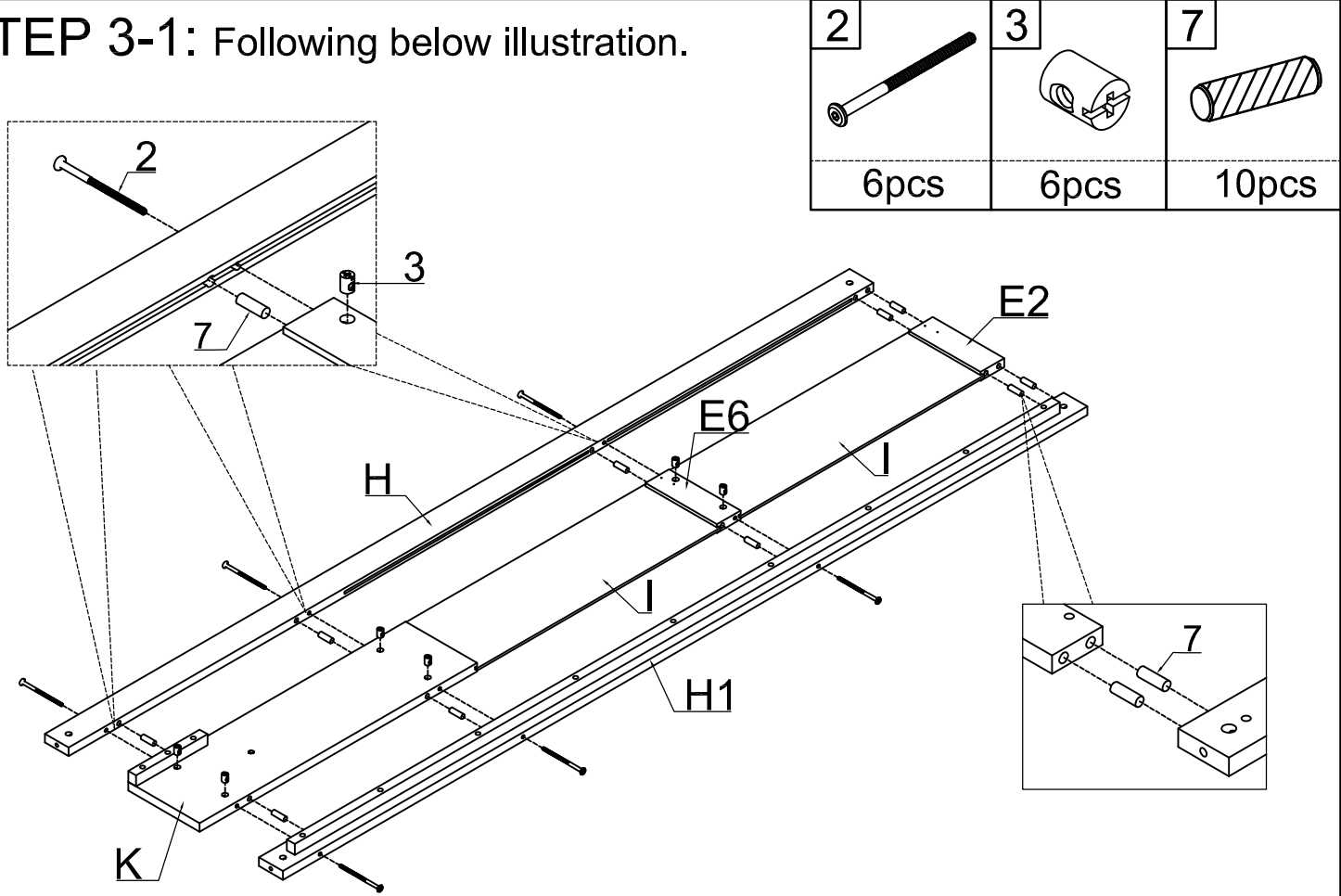

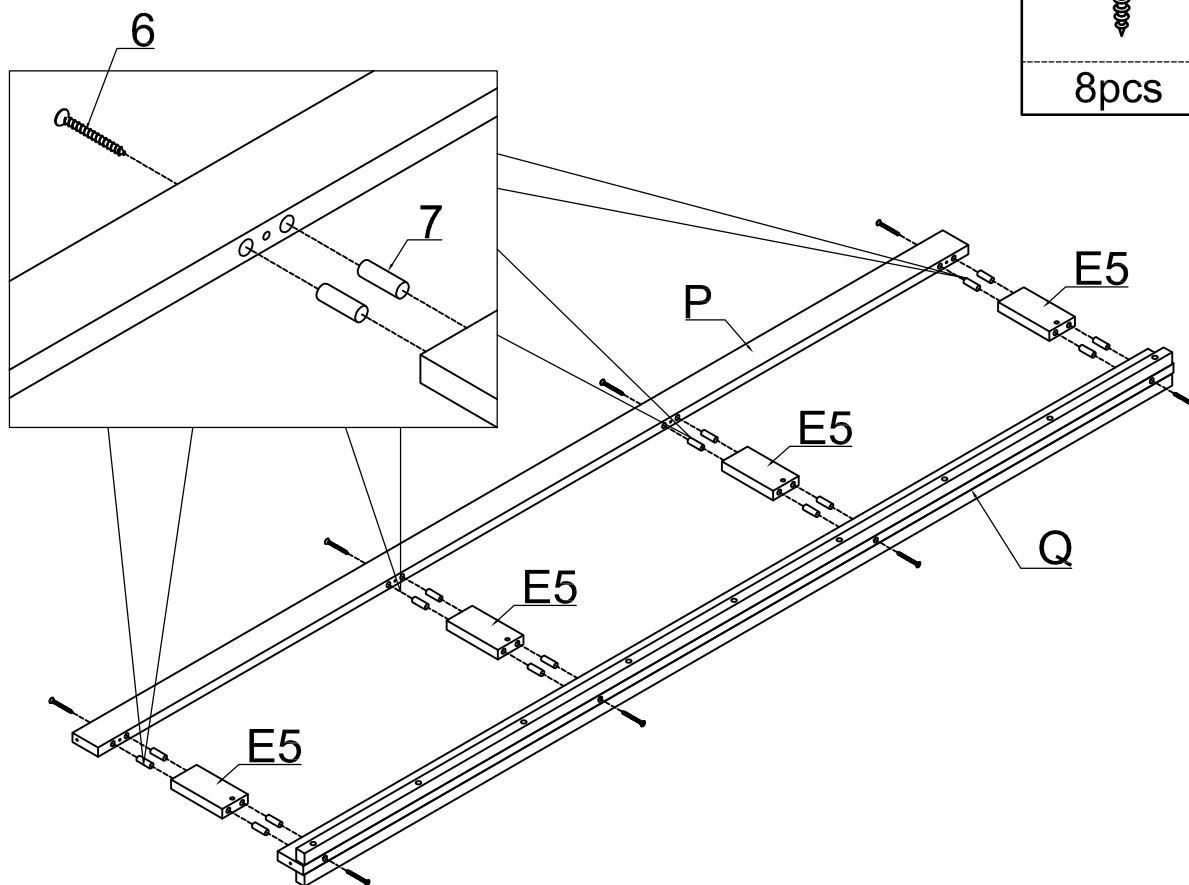

STEP 4: Following below illustration.

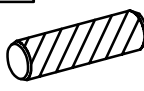

6		7	
8pcs		16pcs	

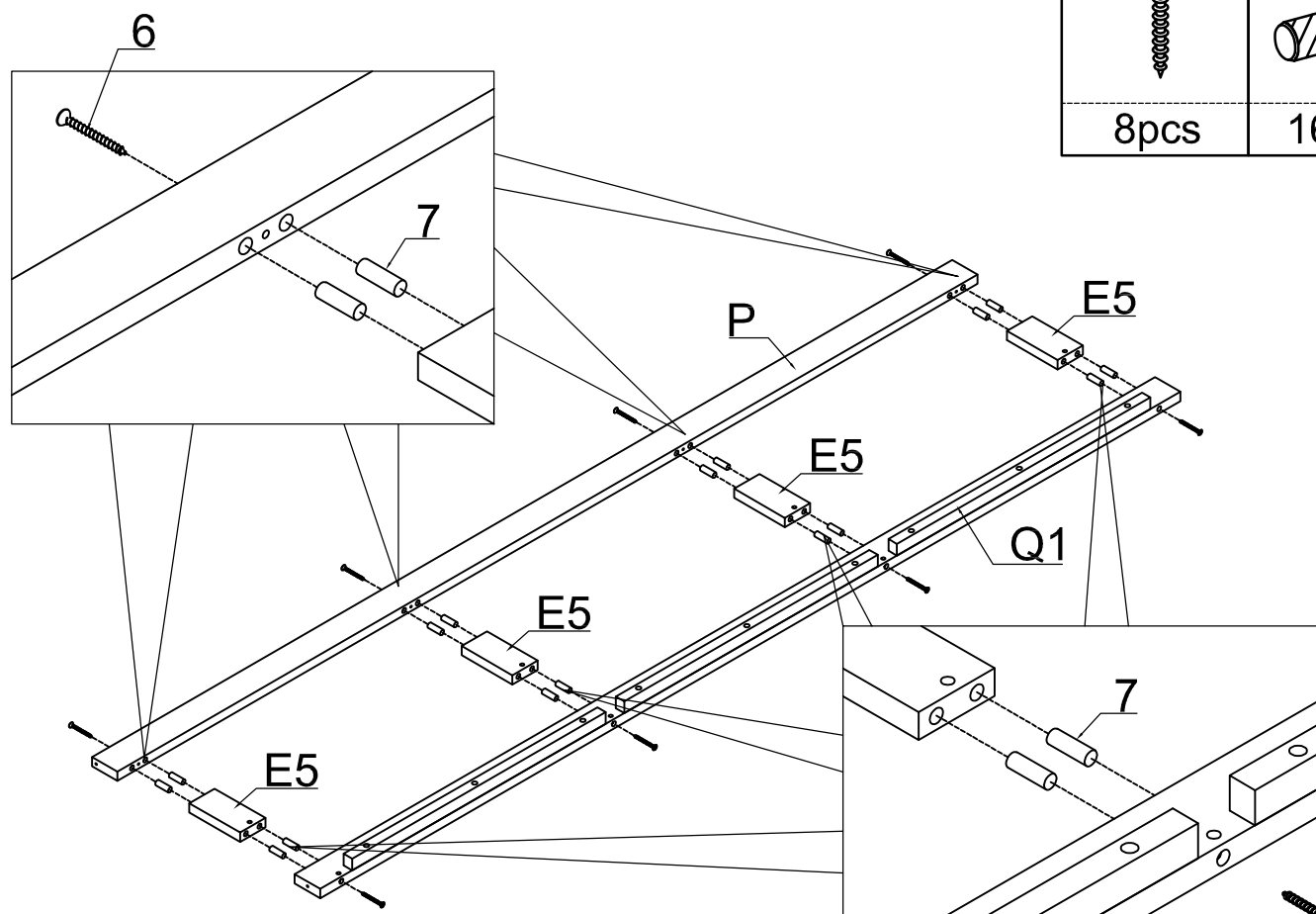
STEP 4-1: Following below illustration.

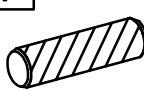

6		7	
8pcs		16pcs	

STEP 5: Following below illustration.

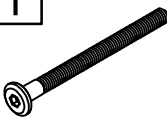
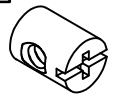
1	3
	
8pcs	8pcs

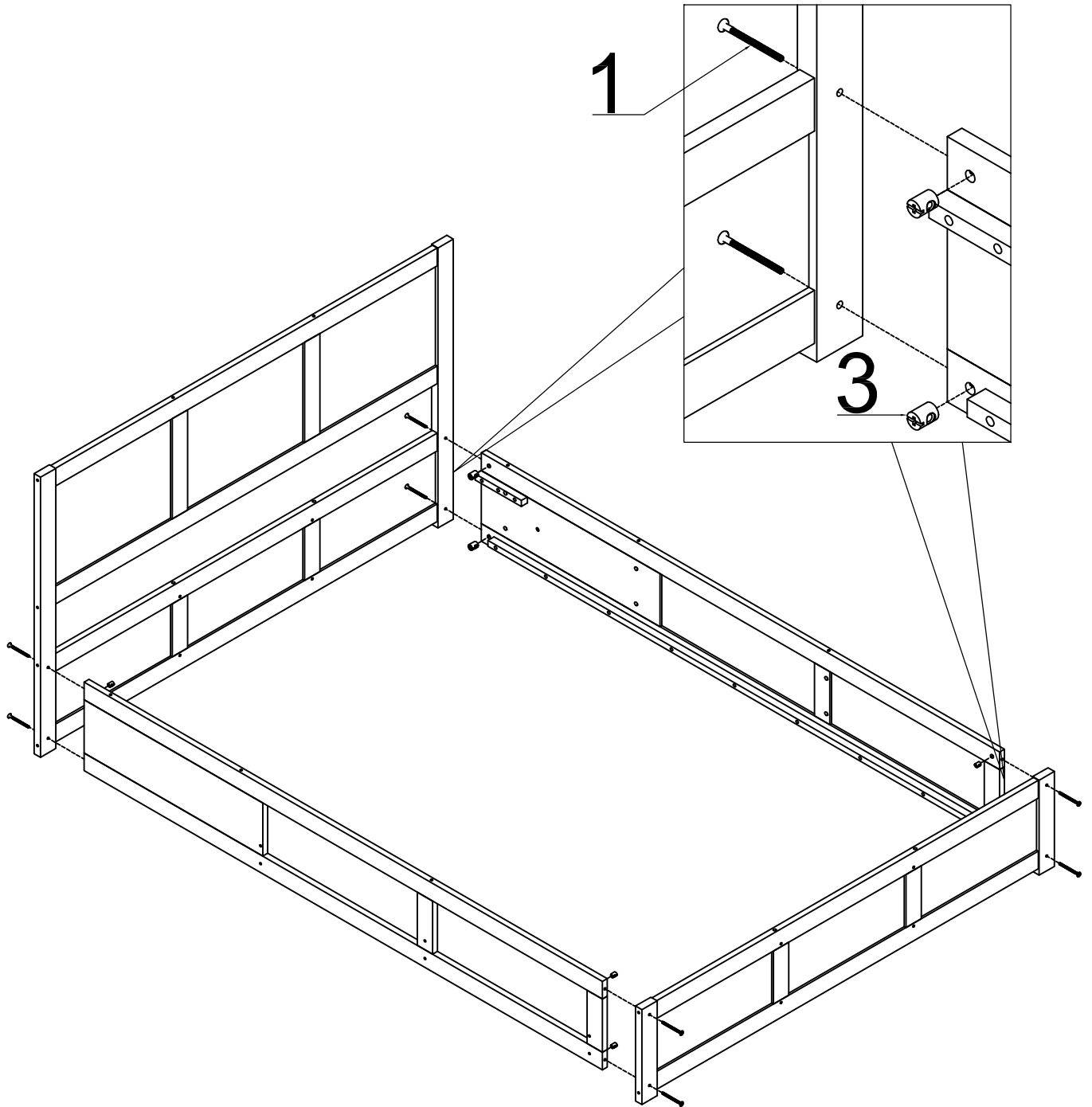

STEP 6: Following below illustration.

10

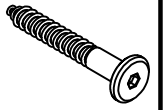

8pcs

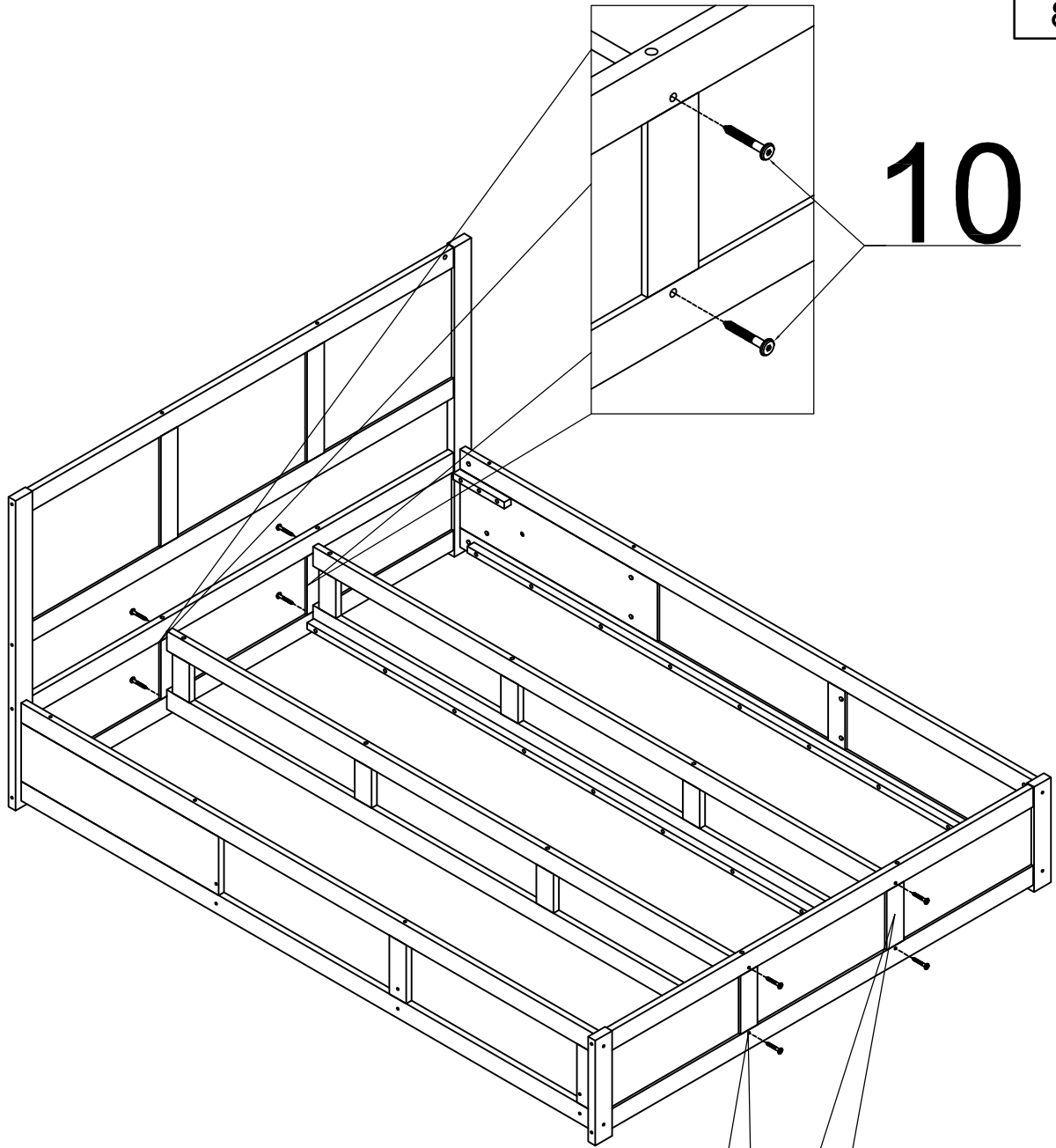

10

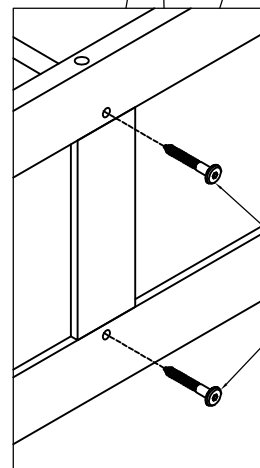

10

STEP 7: Following below illustration.

10

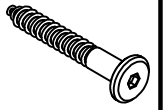

12pcs

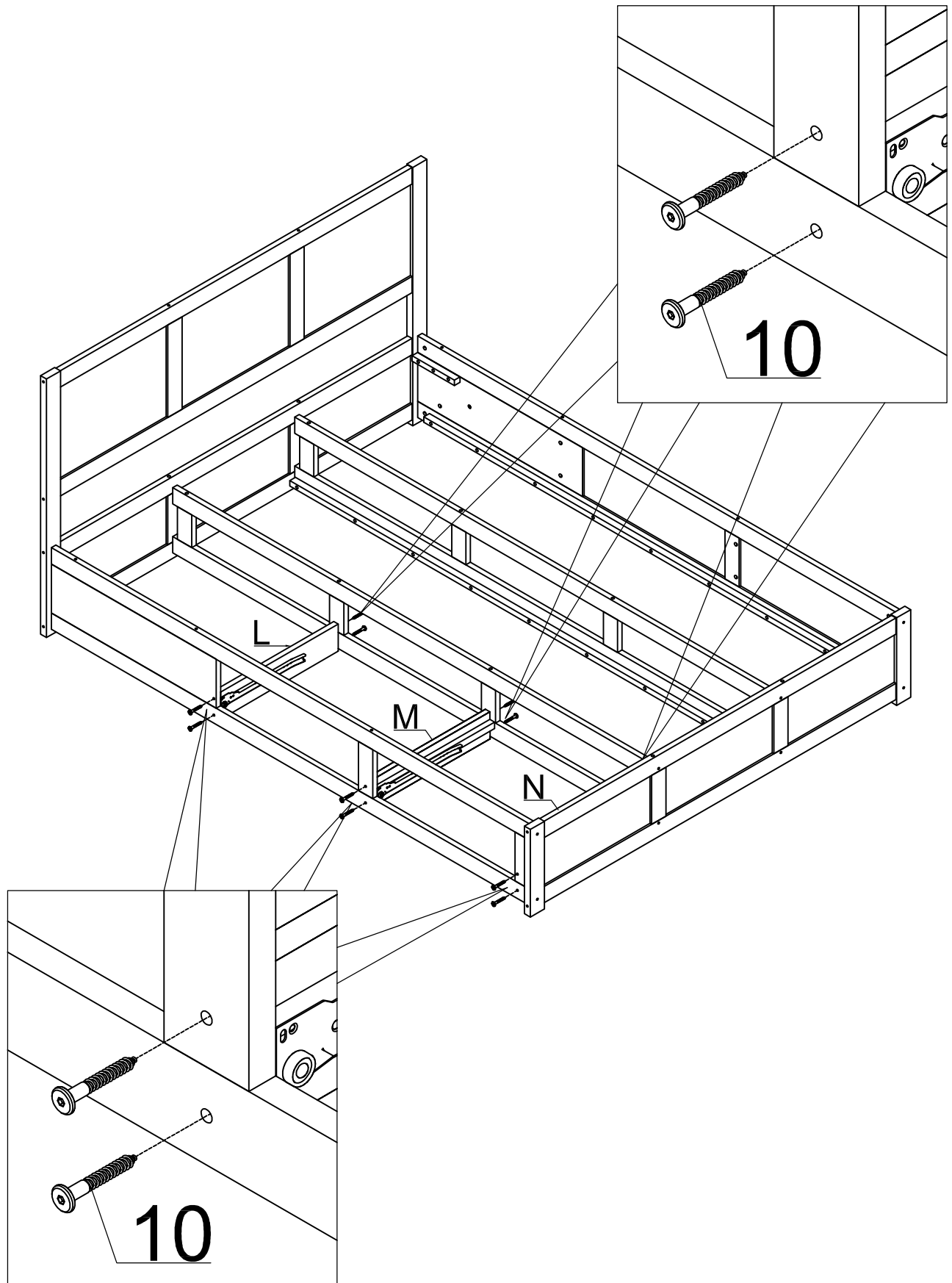

STEP 7: Following below illustration.

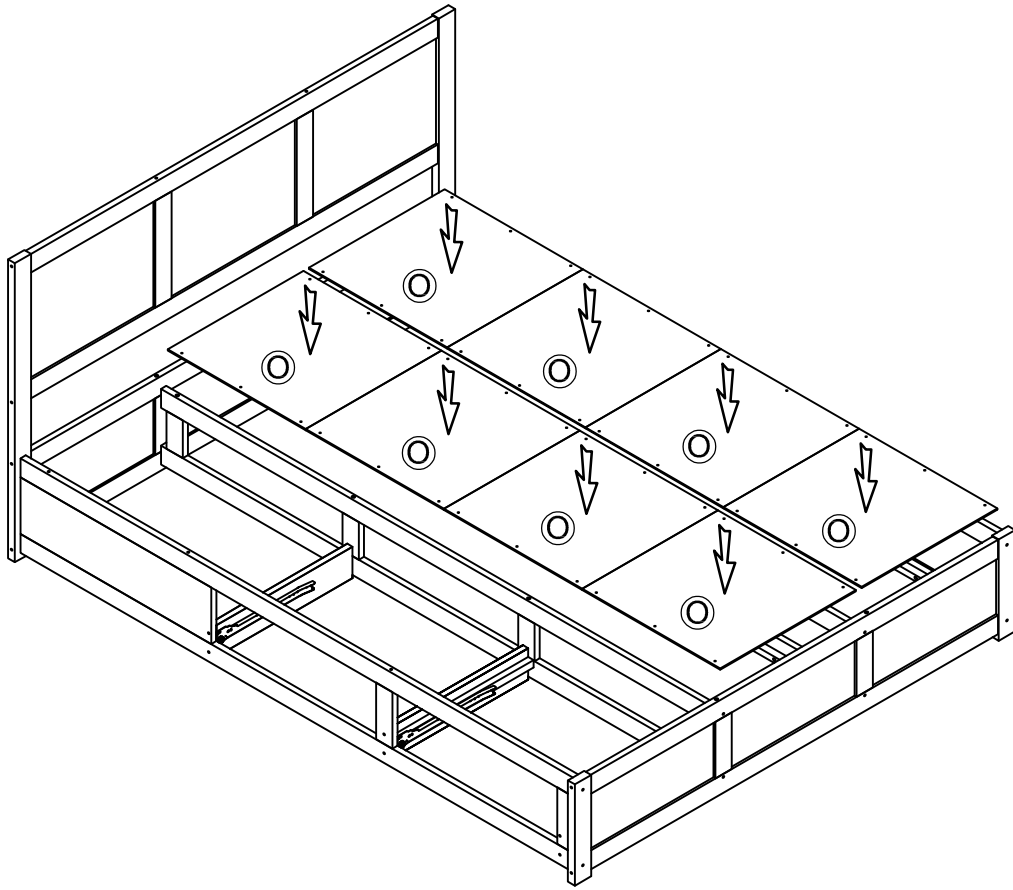

STEP 7-1: Following below illustration.

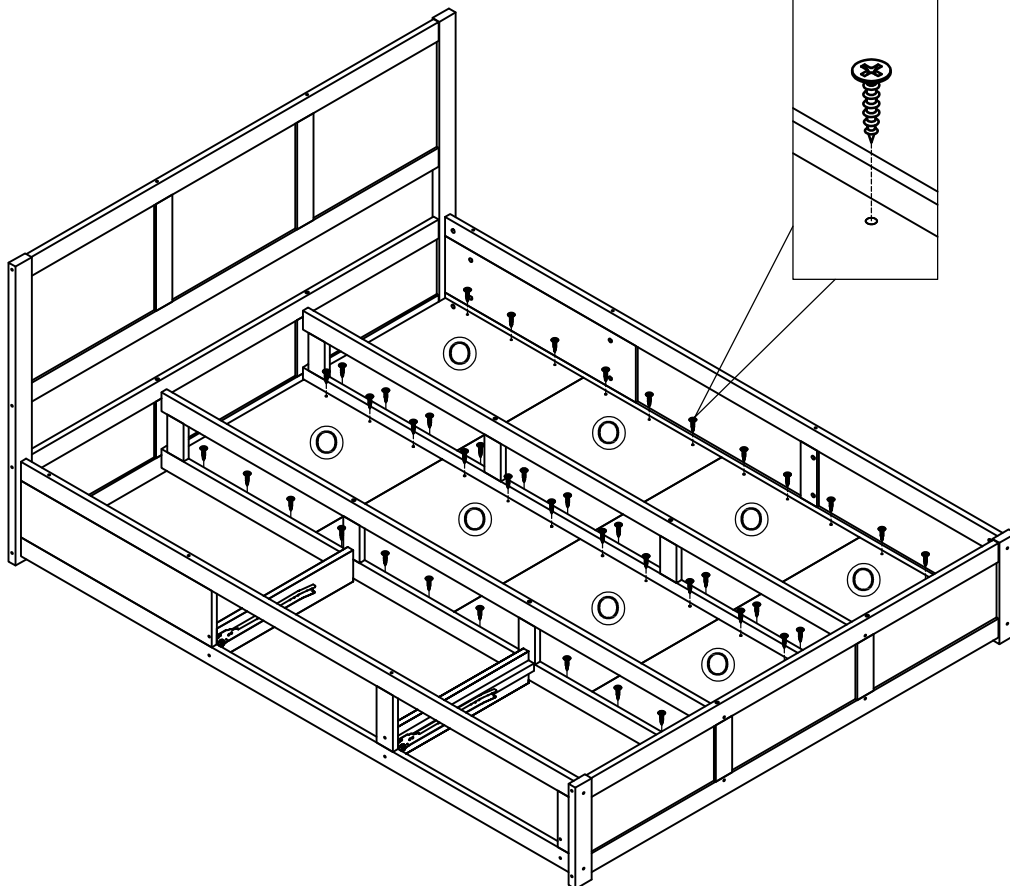

4



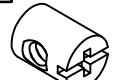
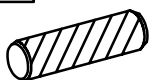

48pcs

STEP 8: Following below illustration.

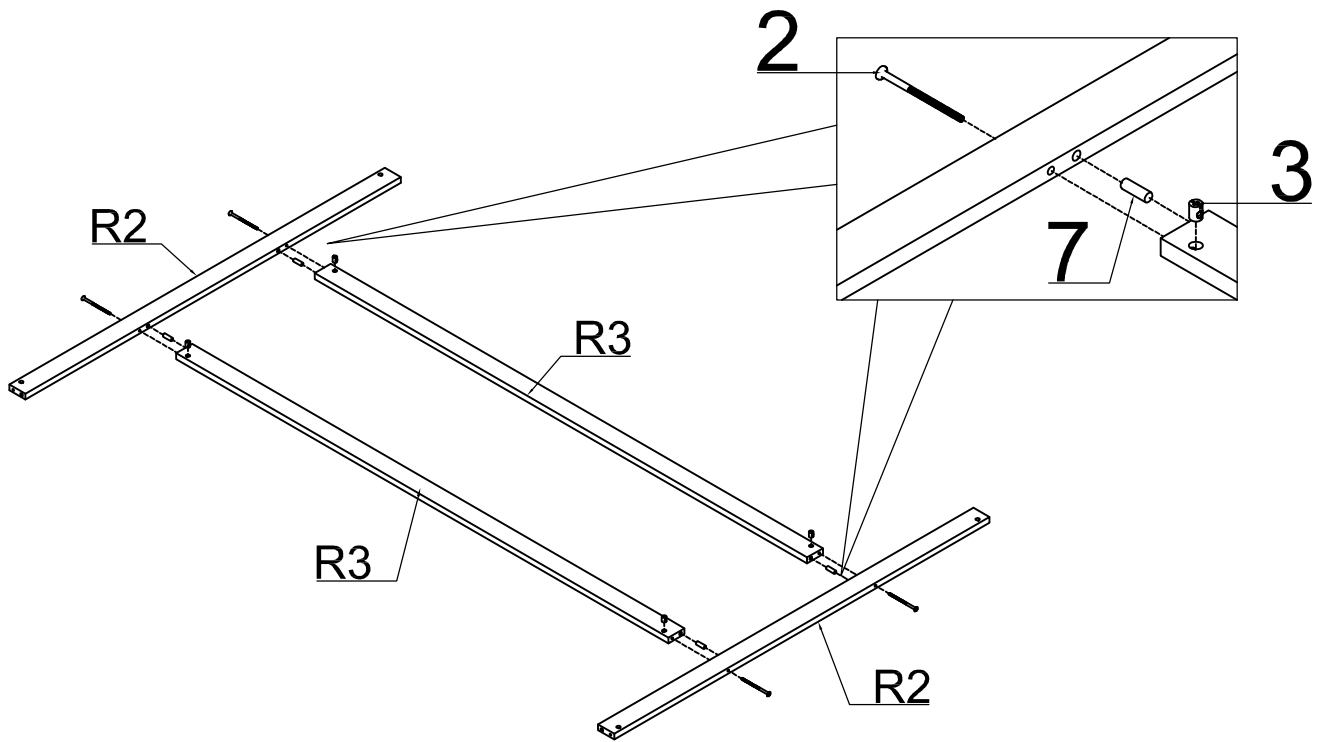
2	3	7
		
4pcs	4pcs	4pcs

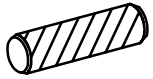

STEP 8-1: Following below illustration.

2	3	7
		
4pcs	4pcs	4pcs

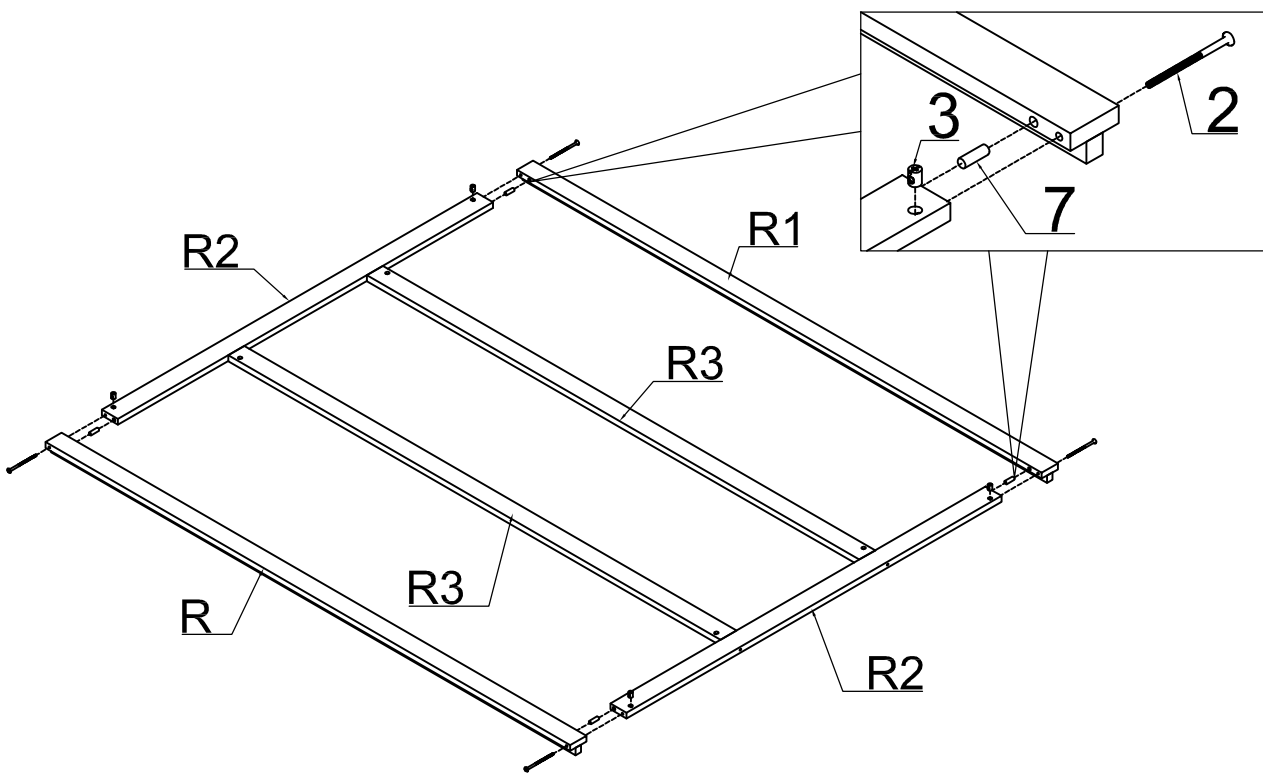

STEP 9: Following below illustration.

5



40pcs

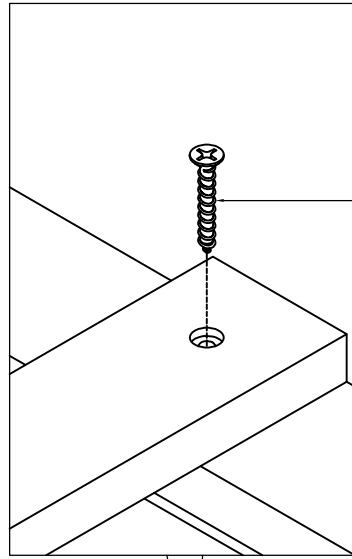

5

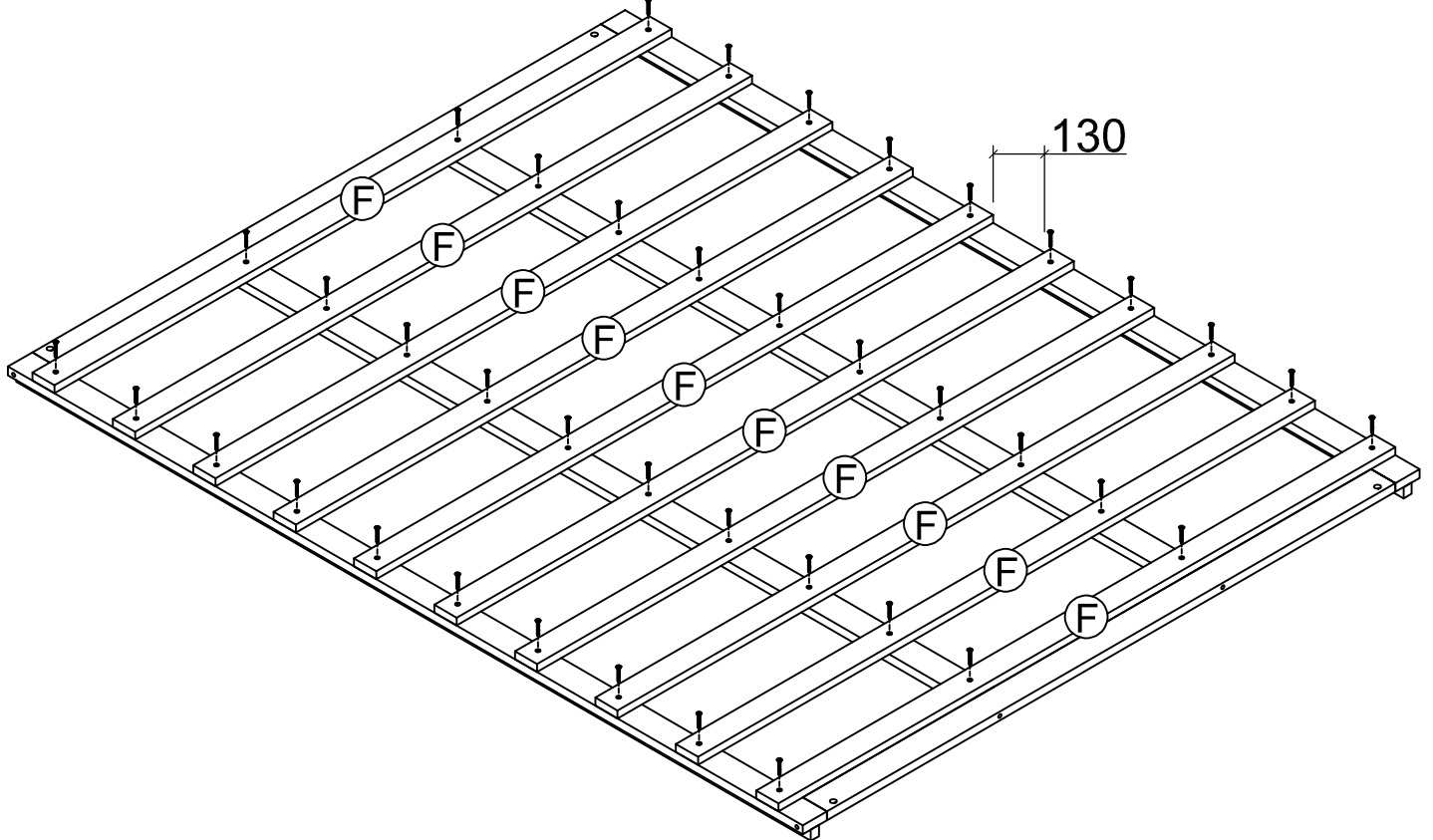

STEP 10: Following below illustration.

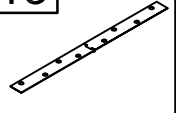
4		13	
16pcs		2pcs	

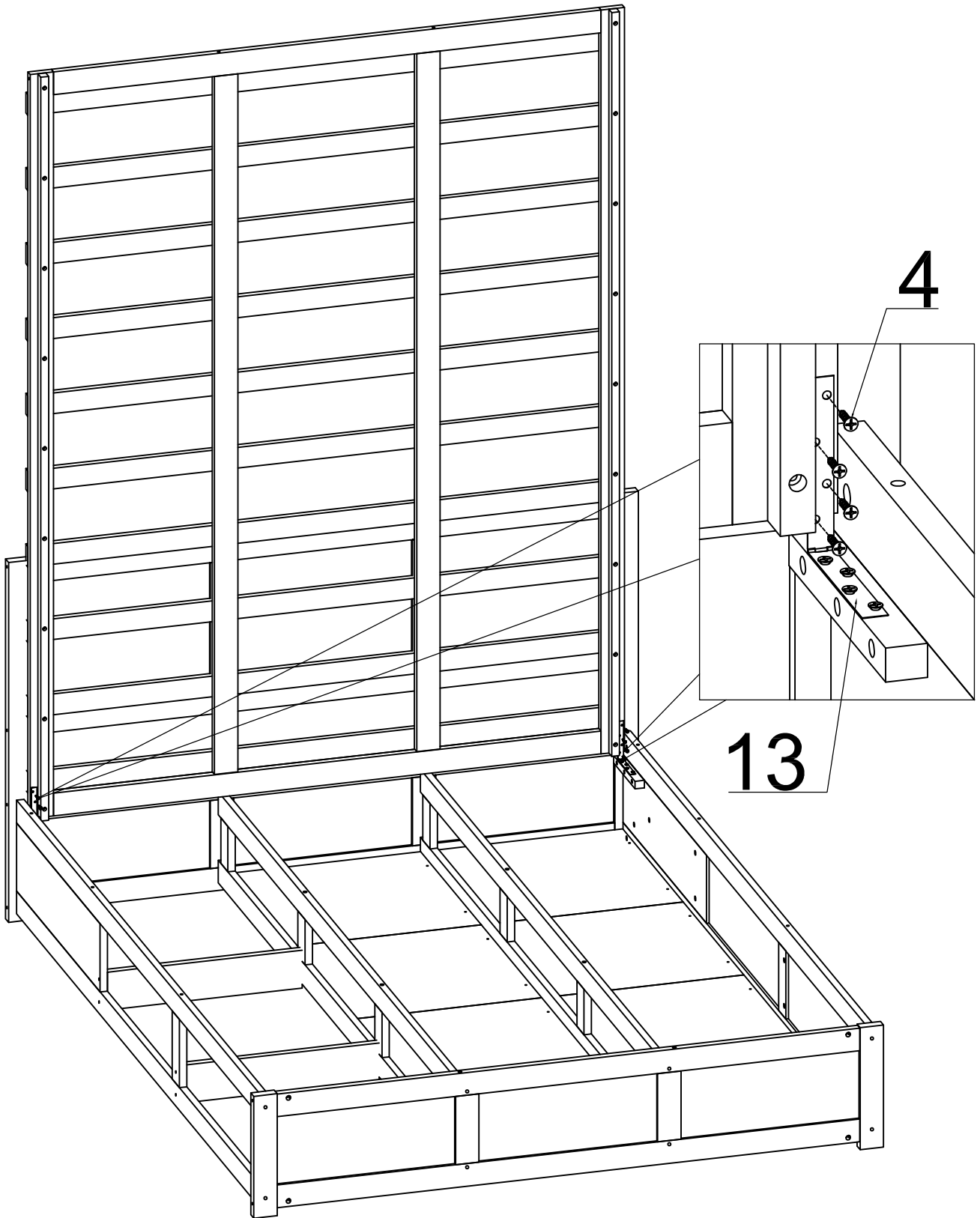

STEP 11:

Following below illustration.

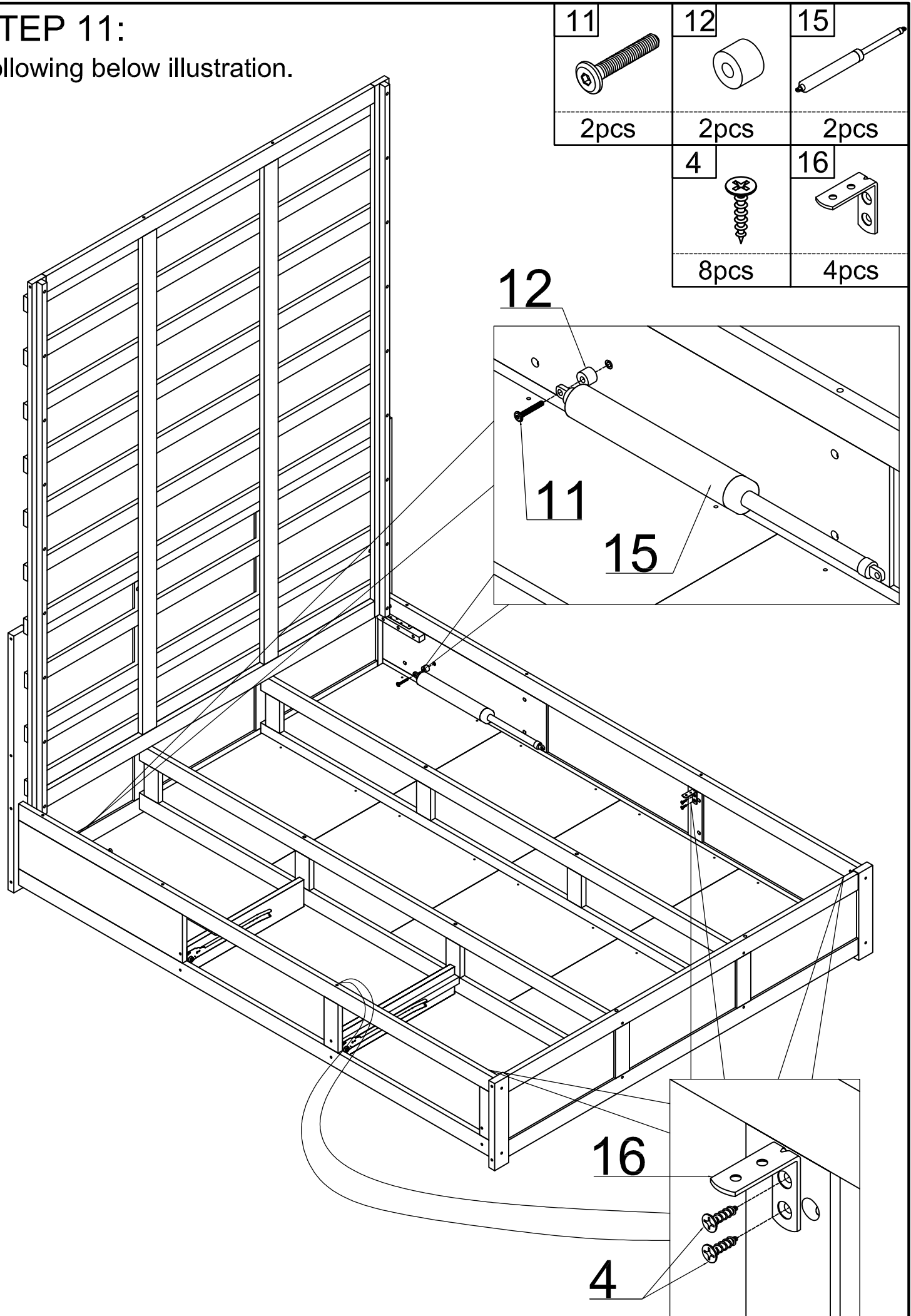

STEP 12: Following below illustration.

11

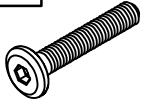

2pcs

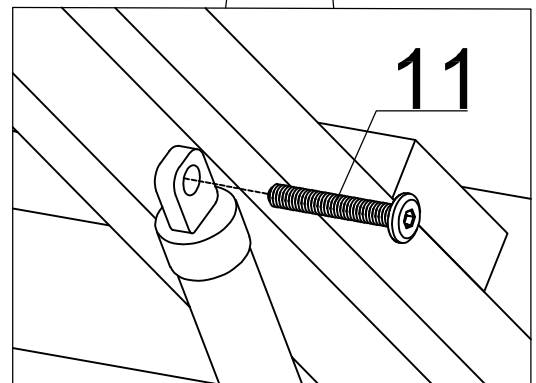
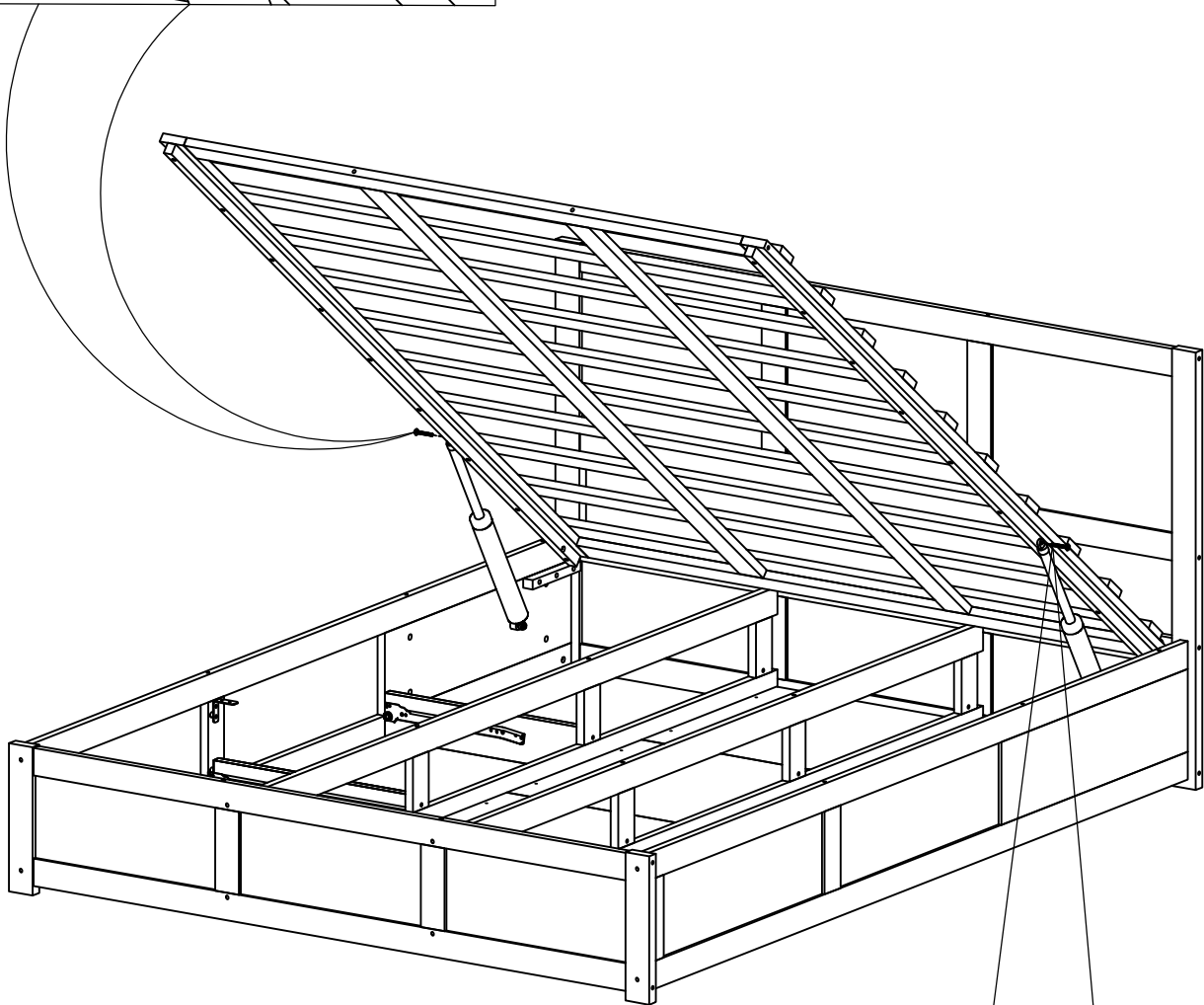
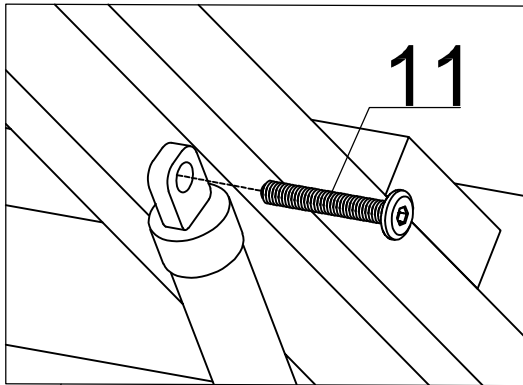

STEP 13: Following below illustration.

5



8pcs

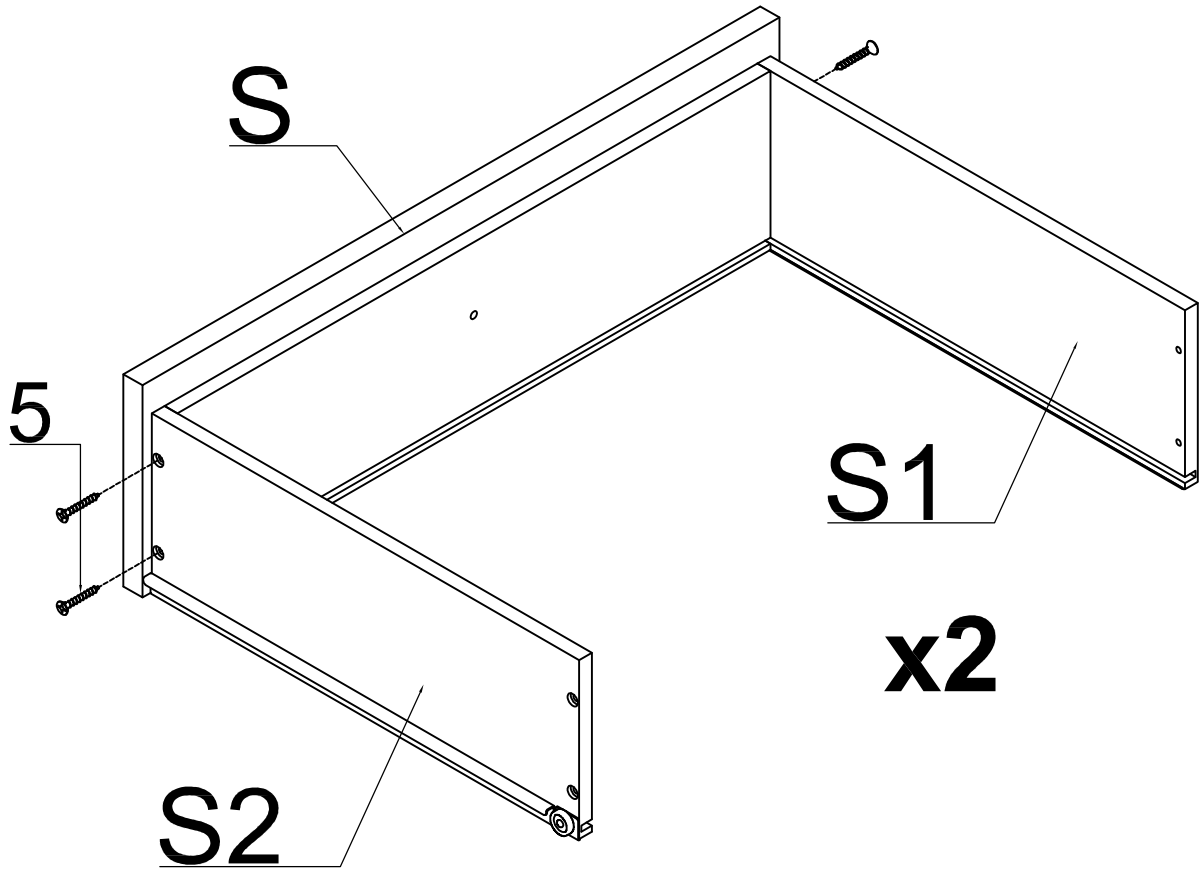

STEP 13-1: Following below illustration.

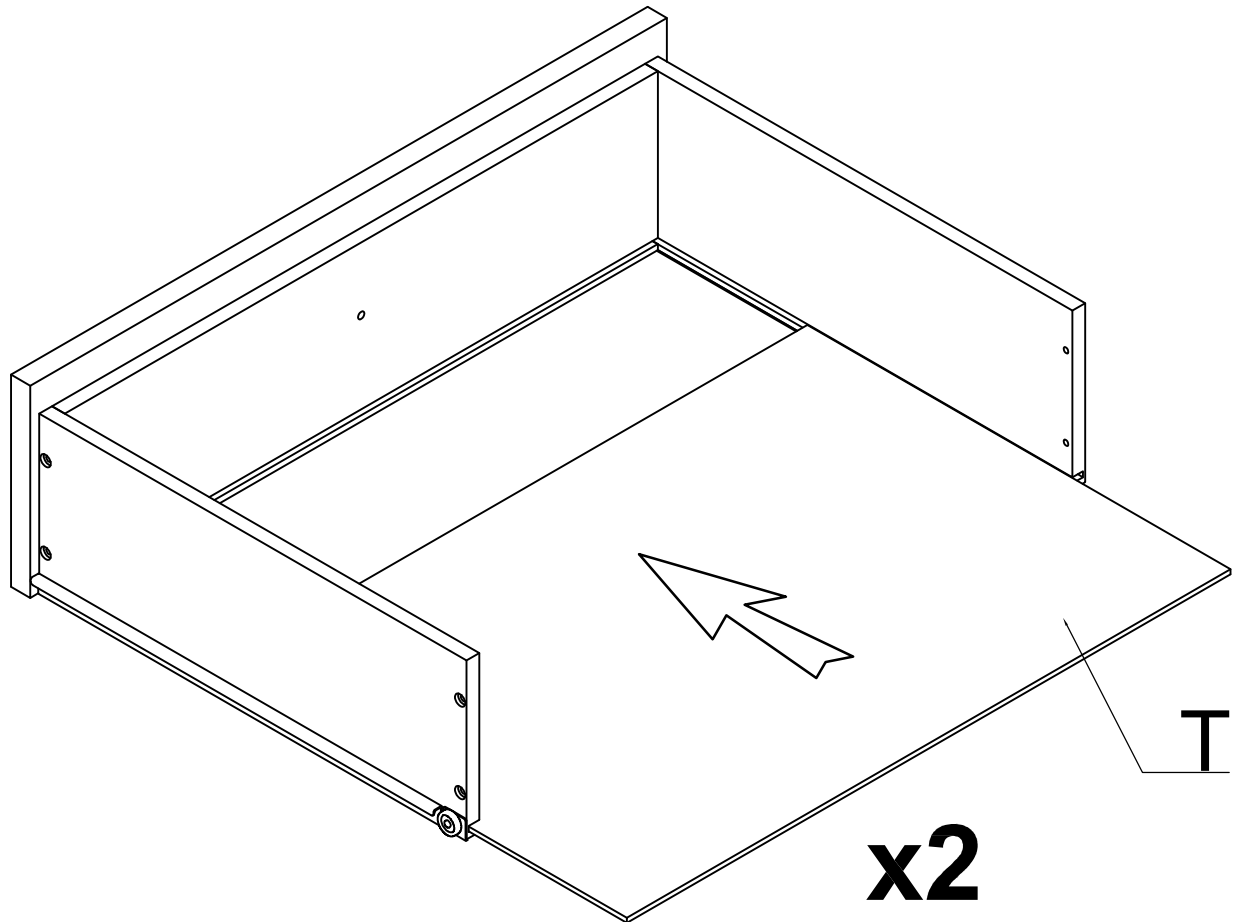

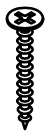

STEP 14: Following below illustration.

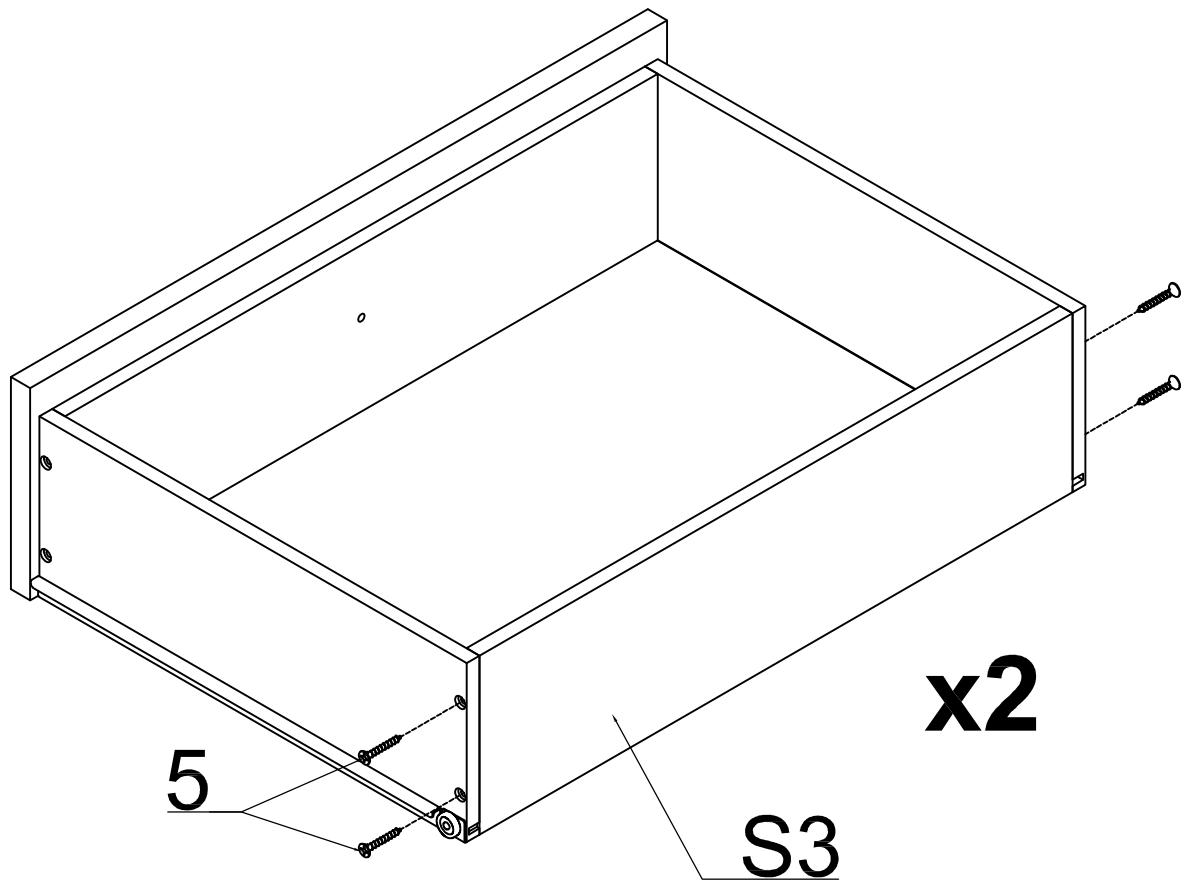
5	
8pcs	



STEP 14-1: Following below illustration.

8		9	
2pcs		2pcs	

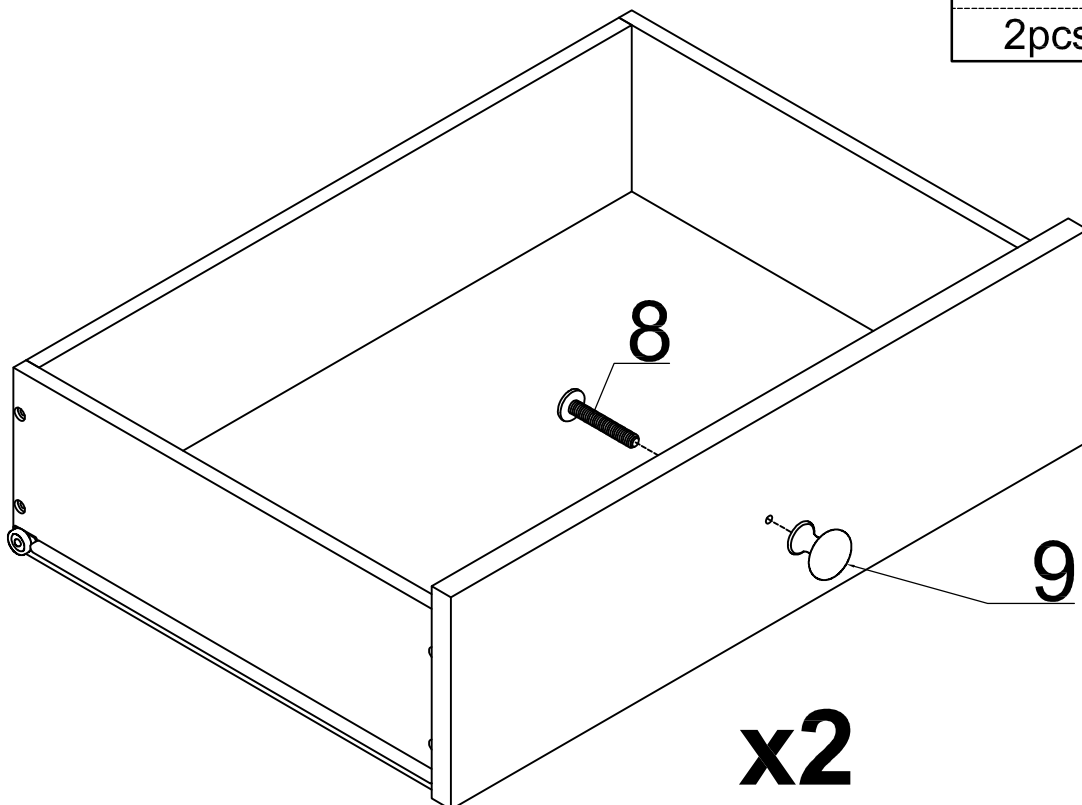

FINISH

