

Assembly Instructions

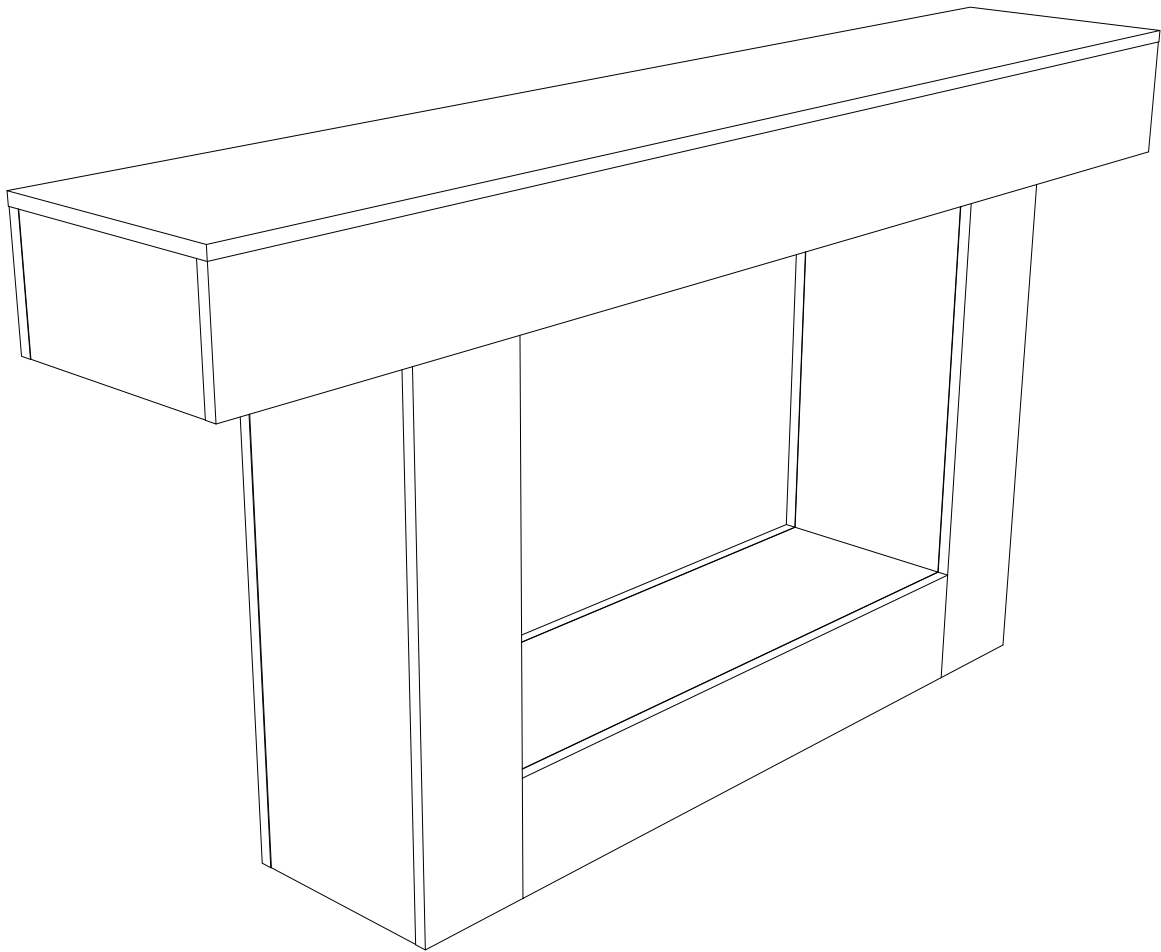

Porch Table

EN - Contact us. We're here to help you.

FR - Contactez-nous. Nous vous aiderons.

DE - Rufen Sie uns an. Wir sind hier, um zu helfen.

IT - Contattateci. Siamo qui per aiutarvi.

ES - Contáctanos, estamos aquí para ayudarte.

EN - We prioritize your satisfaction. Any issues with your product like missing or damaged parts, please keep the package, take photos of the packaging and the product, and contact us quickly.

DE - Ihre Zufriedenheit steht bei uns an erster Stelle. Bei Problemen mit Ihrem Produkt, wie fehlenden oder beschädigten Teilen, bewahren Sie bitte die Verpackung auf, machen Sie Fotos von der Verpackung und dem Produkt und kontaktieren Sie uns schnell.

IT - Diamo priorità alla vostra soddisfazione. In caso di problemi con il prodotto, come parti mancanti o danneggiate, si prega di conservare la confezione, scattare foto dell'imballaggio e del prodotto e contattarci rapidamente.

FR - Votre satisfaction est notre priorité. En cas de problème avec votre produit, comme des pièces manquantes ou endommagées, veuillez conserver l'emballage, prendre des photos de l'emballage et du produit et nous contacter rapidement.

ES - Su satisfacción es nuestra prioridad primordial. Si tiene algún inconveniente con este producto, como faltantes o dañadas, estamos aquí para ayudarte. Guarda el embalaje original y toma fotos luego contáctanos lo antes posible.

Warm Tips

EN

1. Carefully read and keep these instructions for later.
2. Before assembling, ensure all parts and accessories are there.
3. Assemble on a soft, smooth surface like a carpet to avoid scratches.
4. Don't fully tighten the screws until everything is correctly in place.

DE

1. Lesen Sie diese Anleitung sorgfältig durch und bewahren Sie sie für später auf.
2. Stellen Sie vor dem Zusammenbau sicher, dass alle Teile und Zubehörteile vorhanden sind.
3. Montieren Sie es auf einer weichen, glatten Oberfläche wie einem Teppich, um Kratzer zu vermeiden.
4. Ziehen Sie die Schrauben nicht vollständig an, bis alles richtig sitzt.

IT

1. Leggere attentamente e conservare le presenti istruzioni.
2. Prima di procedere al montaggio, accertarsi che tutte le parti e gli accessori siano presenti.
3. Montare su una superficie morbida e liscia, come un tappeto, per evitare graffi.
4. Non serrare completamente le viti finché tutto non è stato posizionato correttamente.

FR

1. Lisez attentivement ces instructions et conservez-les.
2. Avant de procéder à l'assemblage, assurez-vous que toutes les pièces et tous les accessoires sont présents.
3. Effectuez l'assemblage sur une surface douce et lisse, comme un tapis, pour éviter les rayures.
4. Ne serrez pas complètement les vis tant que tout n'est pas correctement en place.

ES

1. Lea atentamente estas instrucciones y consévelas para más adelante.
2. Antes de ensamblar, asegúrese de que todas las piezas y accesorios estén en su lugar.
3. Ensamble sobre una superficie suave y lisa, como una alfombra, para evitar rayones.
4. No ajuste completamente los tornillos hasta que todo esté correctamente colocado.

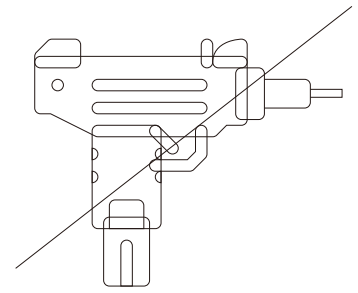
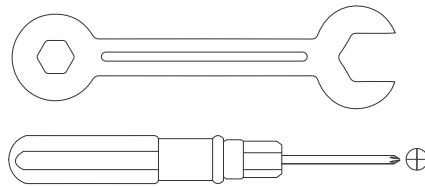
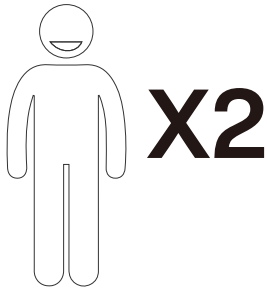

EN - We recommend using hand tools for assembly.

If an electric screwdriver is used, reduce its power to protect the product.

DE - Wir empfehlen die Verwendung von Handwerkzeugen für die Montage.

Wenn ein elektrischer Schraubendreher verwendet wird, reduzieren Sie die Leistung, um das Produkt zu schützen.

IT - Per l'assemblaggio si consiglia di utilizzare utensili manuali.

Se si utilizza un cacciavite elettrico, ridurne la potenza per proteggere il prodotto.

FR - Nous recommandons d'utiliser des outils manuels pour l'assemblage.

Remarque: Si un tournevis électrique est utilisé, réduisez sa puissance pour protéger le produit.

ES - Recomendamos utilizar herramientas manuales para el montaje.

Si se utiliza destornillador eléctrico, reduzca la potencia y el par de torsión para evitar dañar el producto.

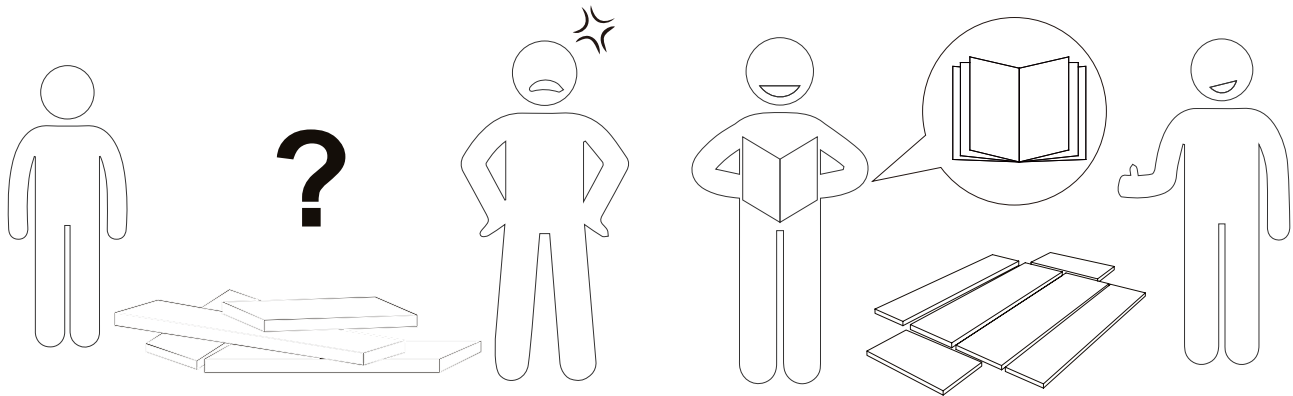

EN - AVOID SCRATCHES

In order to avoid scratching, this furniture should be assembled on a soft surface, such as a rug.

DE - KRATZER VERMEIDEN

Um Beschädigungen vorzubeugen, sollte dieses Möbelstück auf einer weichen Unterlage, z.B. einem Teppich zusammgebaut werden.

IT - EVITARE I GRAFFI

Per evitare di graffiarlo, questo mobile deve essere montato su una superficie morbida, ad esempio un tappeto.

FR - ÉVITER LES RAYURES

Pour éviter tout dommage, ce meuble doit être assemblé sur une surface souple, par exemple un tapis.

ES - EVITA ARAÑAZOS

Para evitar daños, este mueble debe montarse sobre una superficie blanda, por ejemplo, la alfombra.

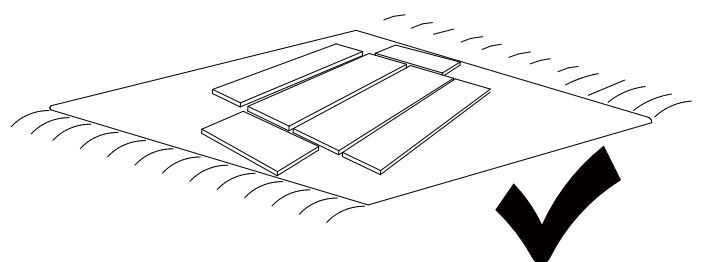
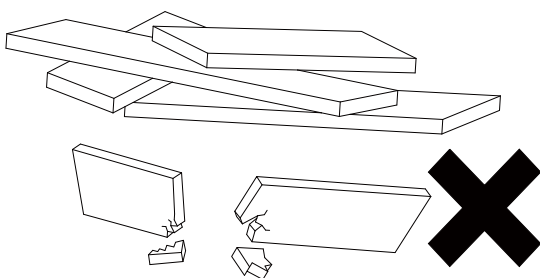

EN - (Install tip-over restraint provided)

Use of tip-over restraints may only reduce but not eliminate, the risk of tip-over.

DE - (Installieren Sie eine Kippsicherung)

Die Verwendung von Kippsicherungen kann das Risiko eines Kippens zwar reduzieren, aber nicht vollständig beseitigen.

IT - (Installare il sistema di ritenuta antiribaltamento in dotazione)

L'uso di dispositivi di sicurezza antiribaltamento può solo ridurre, ma non eliminare, il rischio di ribaltamento.

FR - Installer les Sangles Anti-Basculement

L'utilisation de sangles anti-basculement peut réduire le risque de basculement, mais ne peut pas l'éliminer.

ES - Al utilizar el destornillador eléctrico, reduzca la potencia y el par para evitar dañar los muebles.

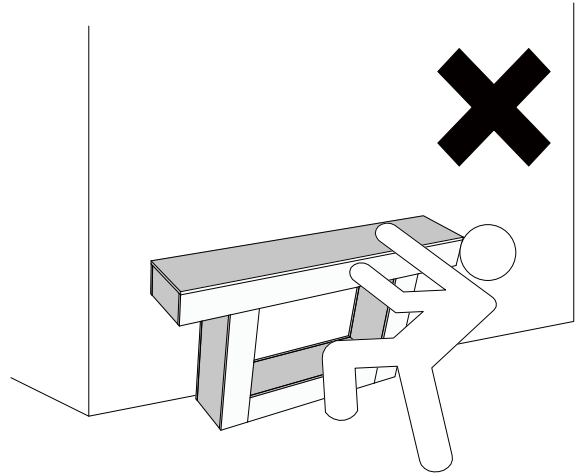
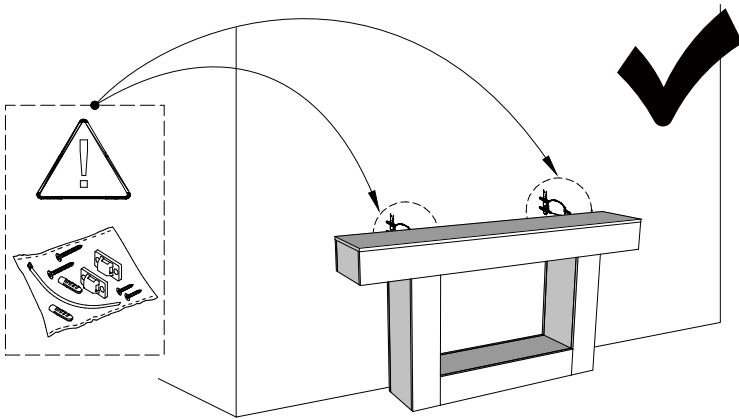

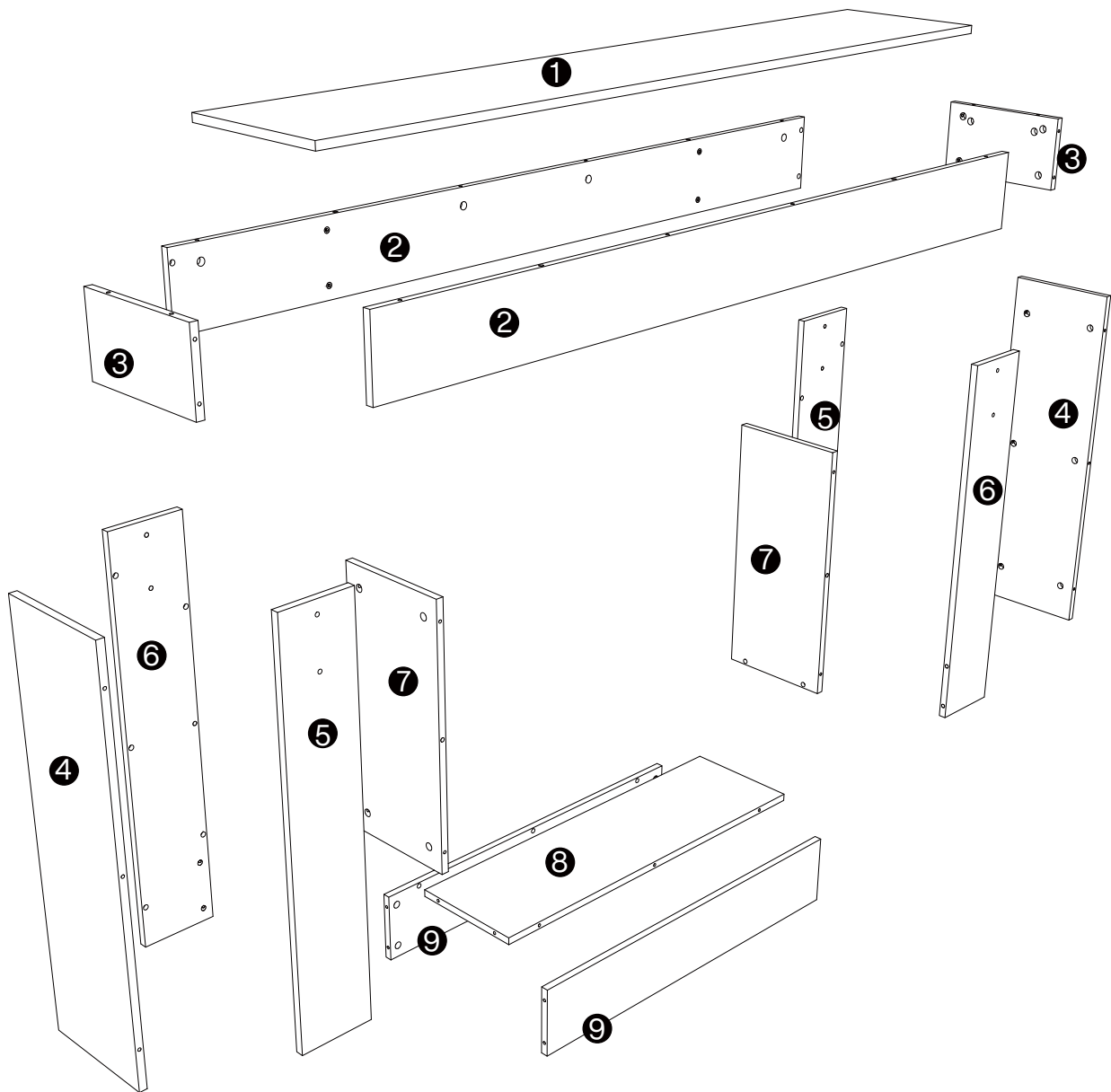

⚠ Caution

EN - Check all parts. Most board parts are labeled on the edge.
Contact us for a free replacement if any are damaged or missing.





DE - Bitte überprüfen Sie alle Teile. Die meisten Platineile sind am Rand beschriftet.
Bitte kontaktieren Sie uns für einen kostenlosen Ersatz, falls etwas fehlt oder beschädigt ist.

IT - Controllare tutte le parti. La maggior parte delle parti della scheda sono etichettate sul bordo.
Contattateci per ottenere una sostituzione gratuita se uno di essi è danneggiato o mancante.

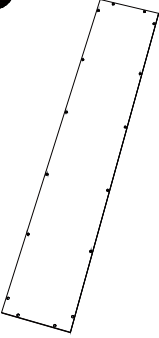
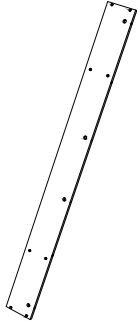
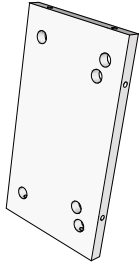
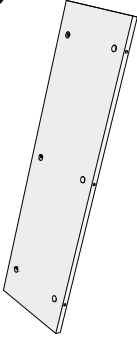
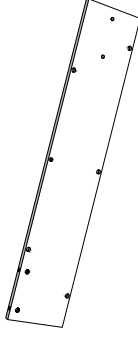
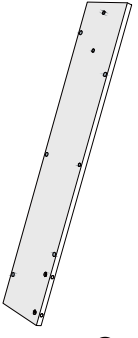
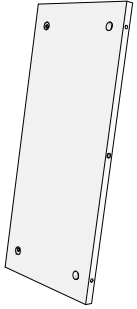
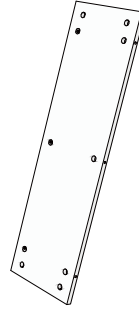
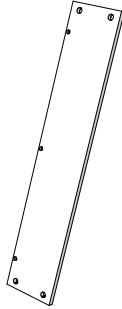
FR - Vérifiez toutes les pièces. La plupart des pièces de la carte sont étiquetées sur le bord.
Contactez-nous pour un remplacement gratuit si l'une d'entre elles est endommagée ou manquante.

ES - Asegúrate de que todas las piezas estén incluidas. La mayoría de las piezas de la tabla están etiquetadas y estampadas en el borde sin rematar.
Contáctanos para obtener un reemplazo gratuito si encuentras piezas dañadas o faltantes.

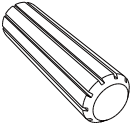
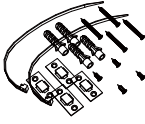
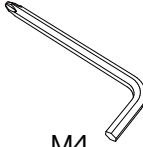
<p>1</p>  <p>1 pc</p>	<p>2</p>  <p>2 pcs</p>	<p>3</p>  <p>2 pcs</p>	<p>4</p>  <p>2 pcs</p>	<p>5</p>  <p>2 pcs</p>
<p>6</p>  <p>2 pcs</p>	<p>7</p>  <p>2 pcs</p>	<p>8</p>  <p>1 pc</p>	<p>9</p>  <p>2 pcs</p>	

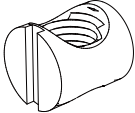
A	B	C	D	E	F	G
 <p>Ø15x12mm</p>	 <p>M6x40mm</p>	 <p>Ø8x30mm</p>		 <p>M4</p>		 <p>M6</p>
58 pcs	58 pcs	8 pcs	1 pc	1 pc	8 pcs	8 pcs

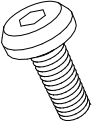
H
 <p>M6x25mm</p>
8 pcs

EN - Installation of Cams and Pins

Read each step carefully before starting. Each step of instruction should be performed in the correct order. If these steps are not followed in sequence, assembly difficulties may occur.

DE - Installation von Nocken und Bolzen

Lesen Sie jeden Schritt sorgfältig durch, bevor Sie beginnen. Es ist sehr wichtig, dass jeder Schritt der Anleitung in der korrekten Reihenfolge ausgeführt wird. Sonst, wird es zu Montageschwierigkeiten kommen.

IT - Installazione di camme e perni

Leggere attentamente ogni fase prima di iniziare. Ogni fase delle istruzioni deve essere eseguita nell'ordine corretto. Se questi passaggi non vengono seguiti in sequenza, possono verificarsi difficoltà di montaggio.

FR - Installation des comes et des axes

Lisez attentivement chaque étape avant de commencer. Chaque étape des instructions doit être effectuée dans le bon ordre. Si ces étapes ne sont pas suivies dans l'ordre, des difficultés d'assemblage peuvent survenir.

ES - Instalación de levas y pernos

Lea cada paso detenidamente antes de comenzar. Es fundamental realizar cada paso de las instrucciones en el orden correcto. De lo contrario, podrían surgir dificultades de instalación.

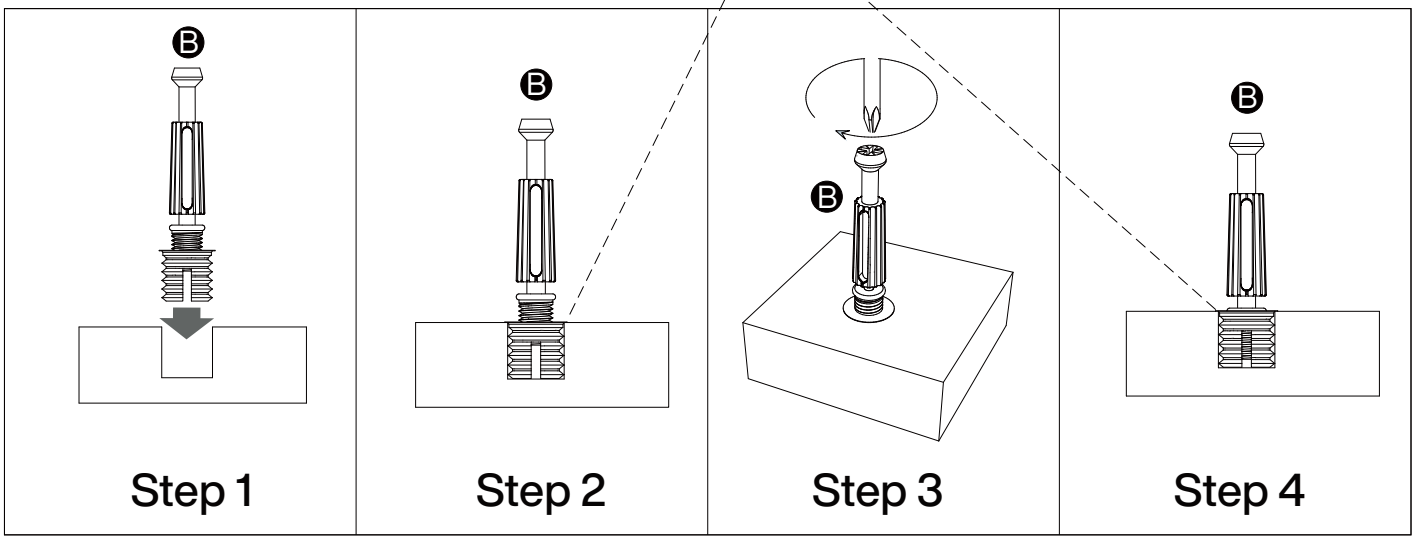
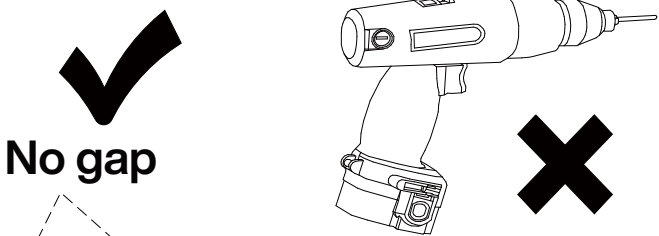

EN - Screw the pin into the hole. Set the cams correctly by aligning the head of the cams with the lock pins. Lock the cam by turning the cam head with a screwdriver until it is tightened. Please do not use an electric screwdriver to assemble the unit.

DE - Schrauben Sie den Bolzen in das Loch. Um die Nocken richtig einzustellen, stellen Sie sicher, dass der Pfeil auf der Nocke zur Lochöffnung des Bolzens zeigt, den sie verriegelt. Verriegeln Sie die Nocke, indem Sie den Nockenkopf mit einem Schraubendreher drehen, bis er festgezogen ist. Bitte verwenden Sie keinen elektrischen Schraubendreher zum Zusammenbau der Einheit.

IT - Avvitare il perno nel foro. Bloccare la camma ruotando la testa della camma con un cacciavite fino a serrarla. Non utilizzare un cacciavite elettrico per assemblare l'unità.

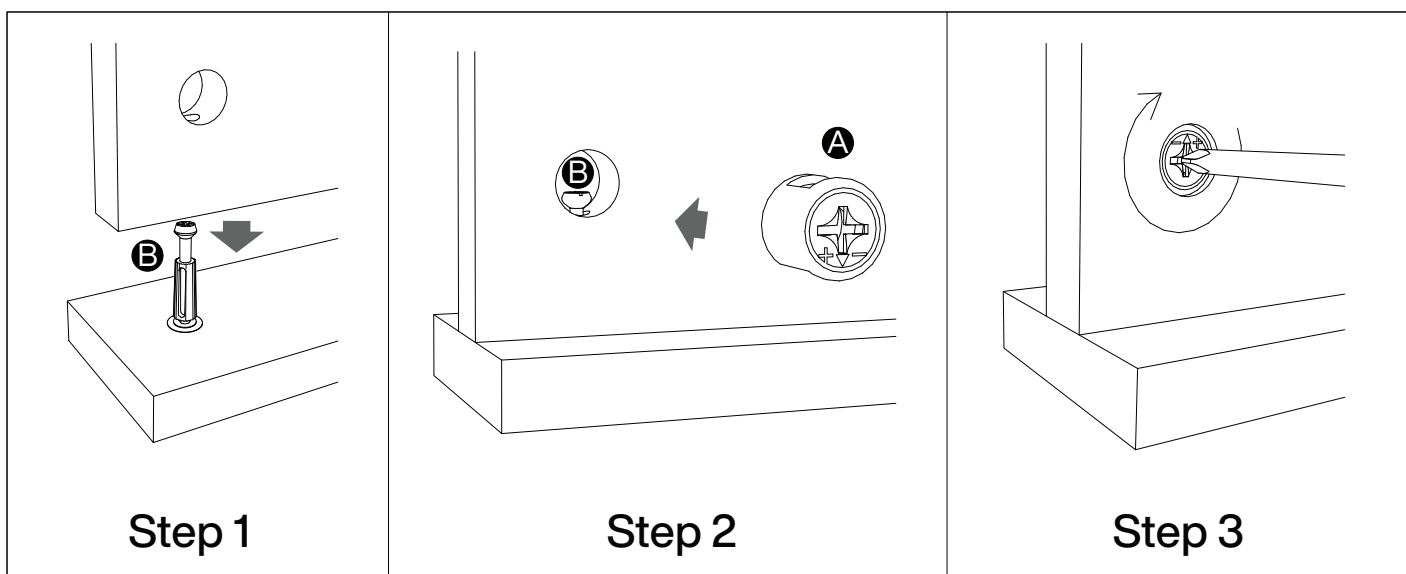

FR - Vissez la goupille dans le trou. Réglez correctement les came en alignant leur tête avec les goupilles de verrouillage. Verrouillez la came en tournant la tête de came à l'aide d'un tournevis jusqu'à ce qu'elle soit serrée. N'utilisez pas de tournevis électrique pour assembler l'appareil.

ES - Atornille el perno en el orificio. Para ajustar correctamente las levas, asegúrese de que la flecha de la leva apunte a la abertura del perno que bloquea. Bloquee la leva girando la cabeza de la leva con un destornillador hasta que esté apretada. No utilice un destornillador eléctrico para ensamblar la unidad.

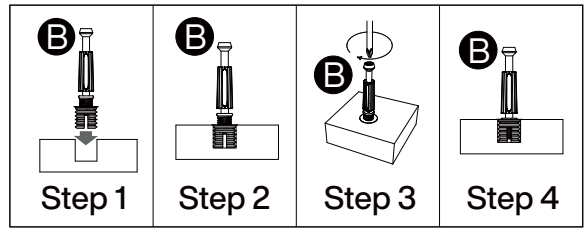

1

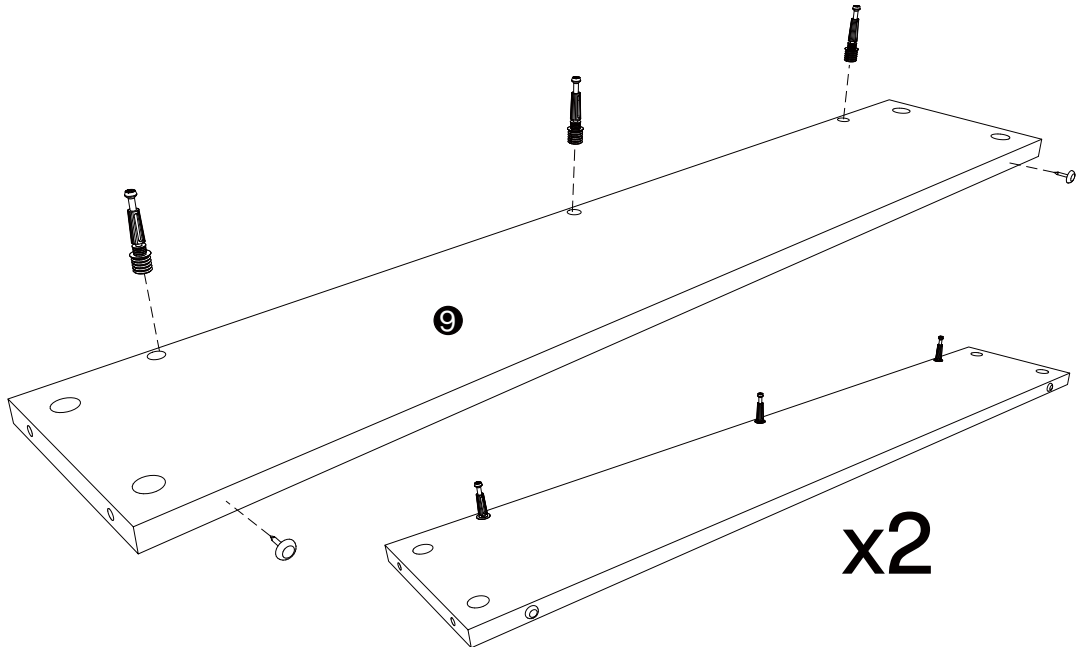

B

M6x40mm
6 pcs
F

4 pcs

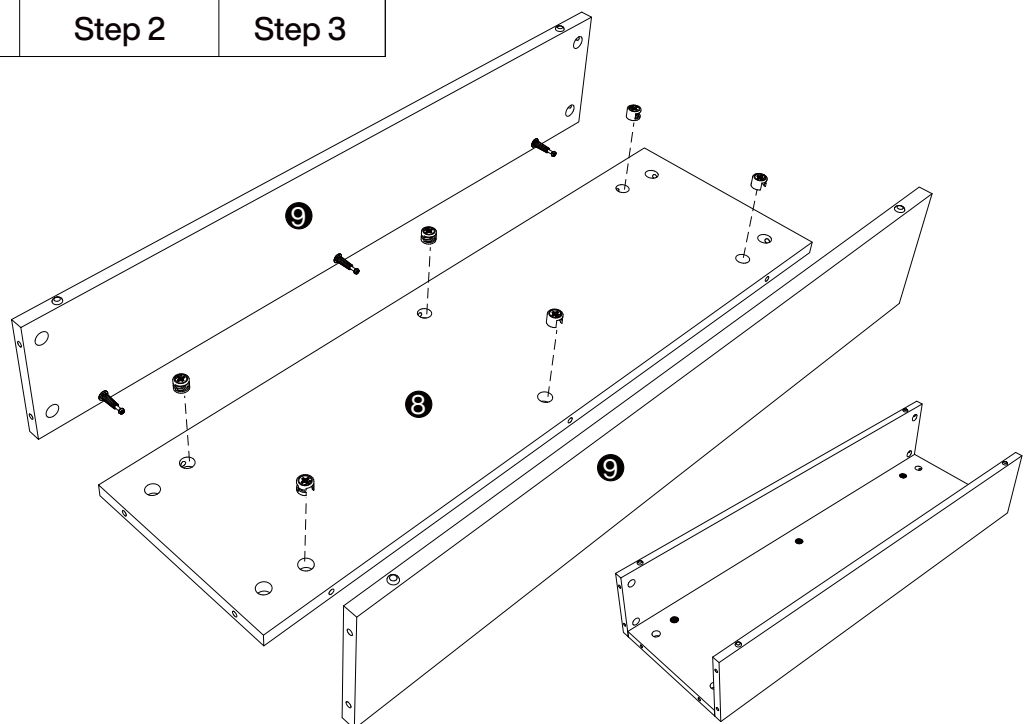
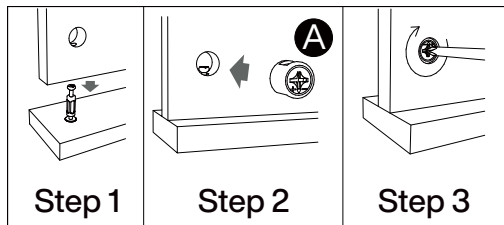



2



A

Ø15x12mm
6 pcs

3

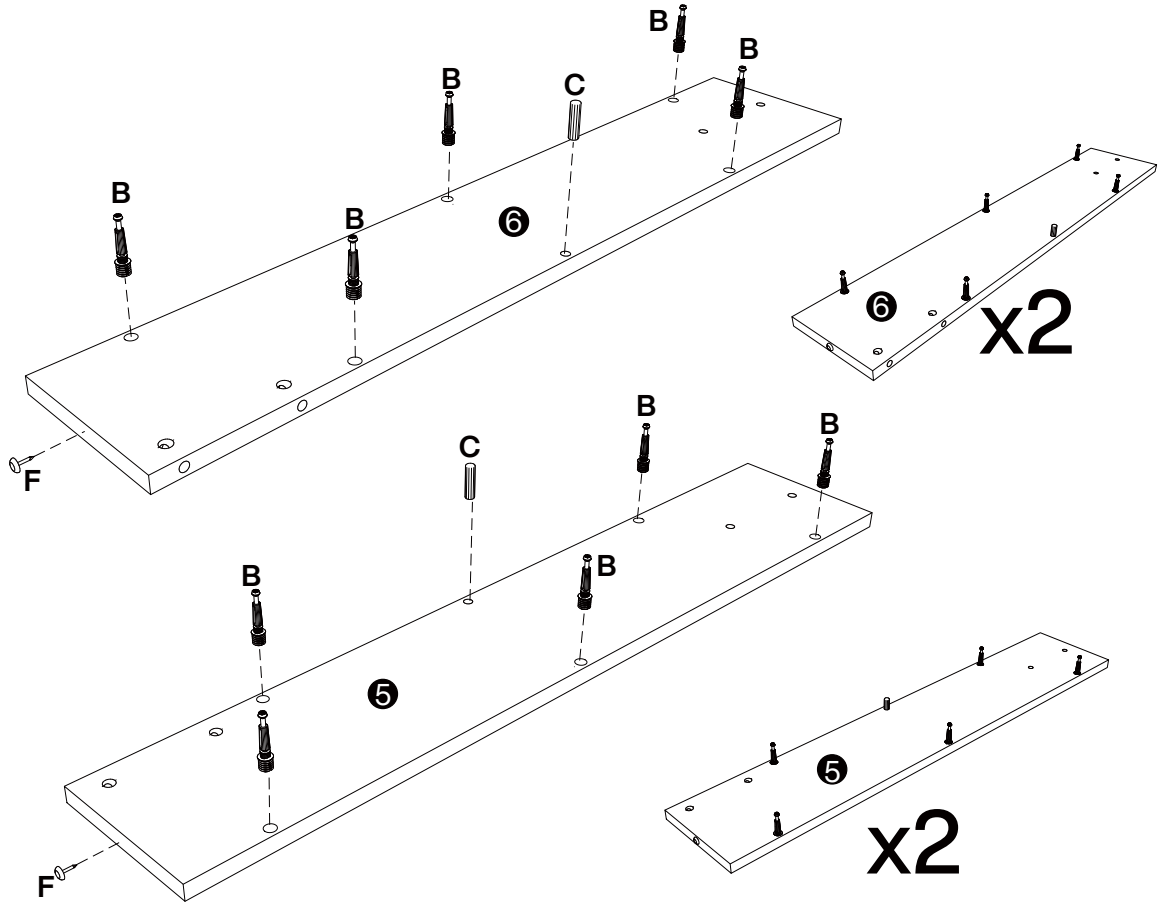
B

M6x40mm 20 pcs
C

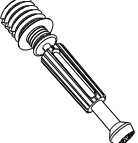
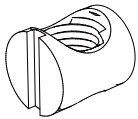
Ø8x30mm 4 pcs
F

4 pcs

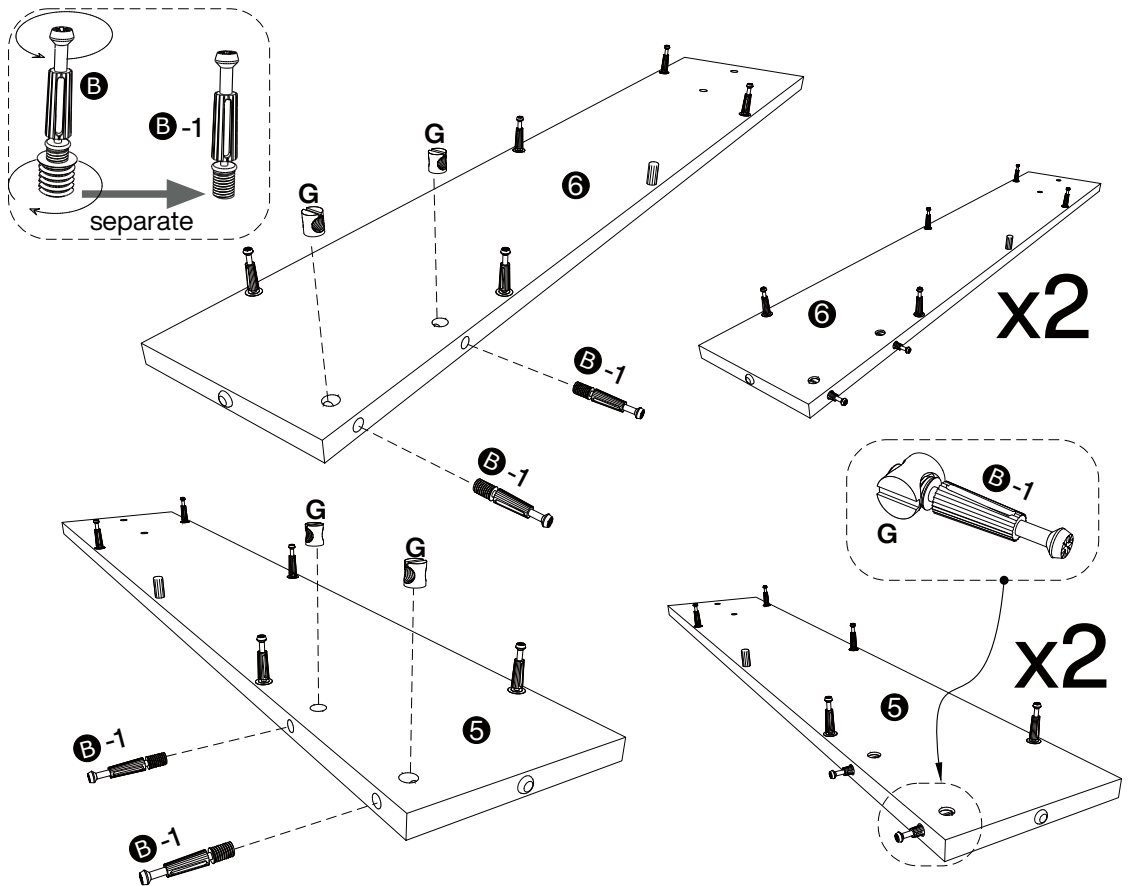

4

B

M6x40mm 8 pcs
G

M6 8 pcs

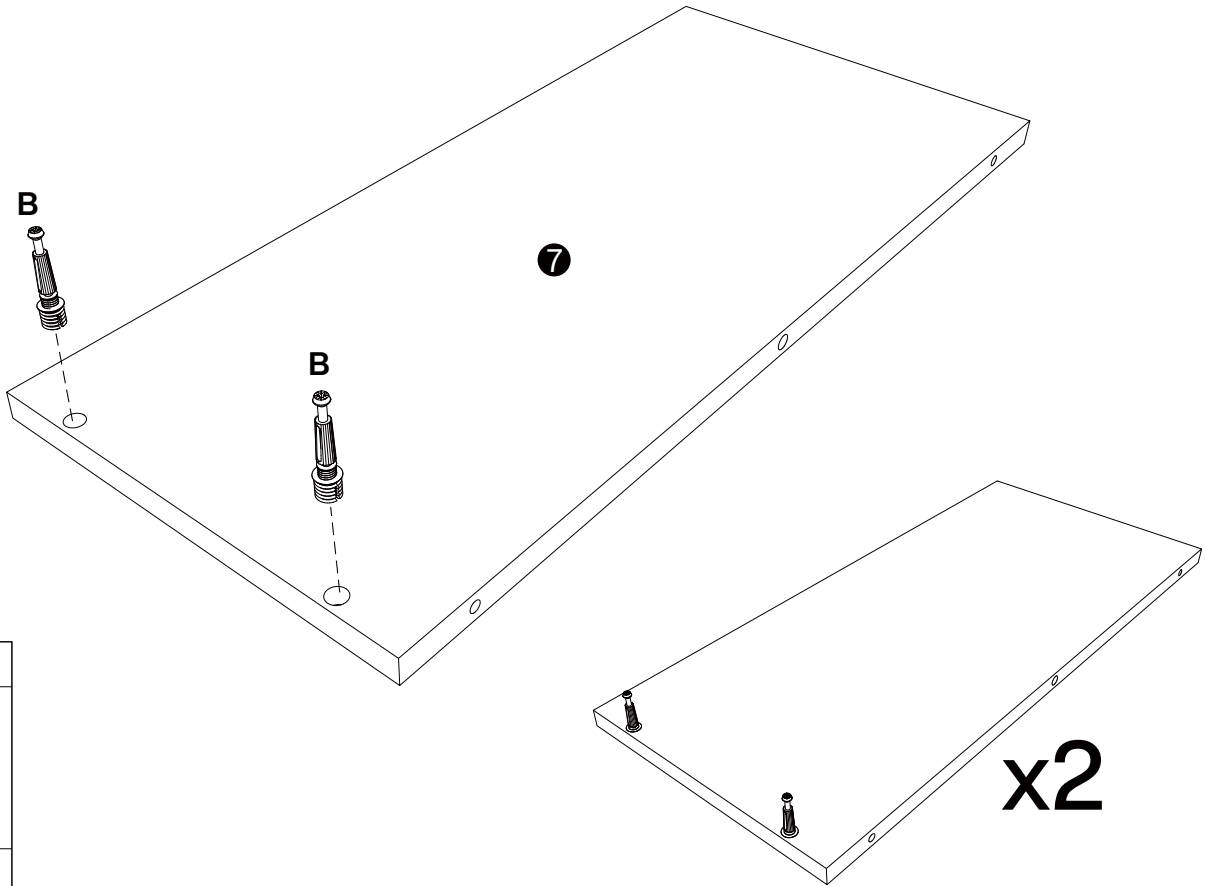

5



B

M6x40mm
4 pcs

6

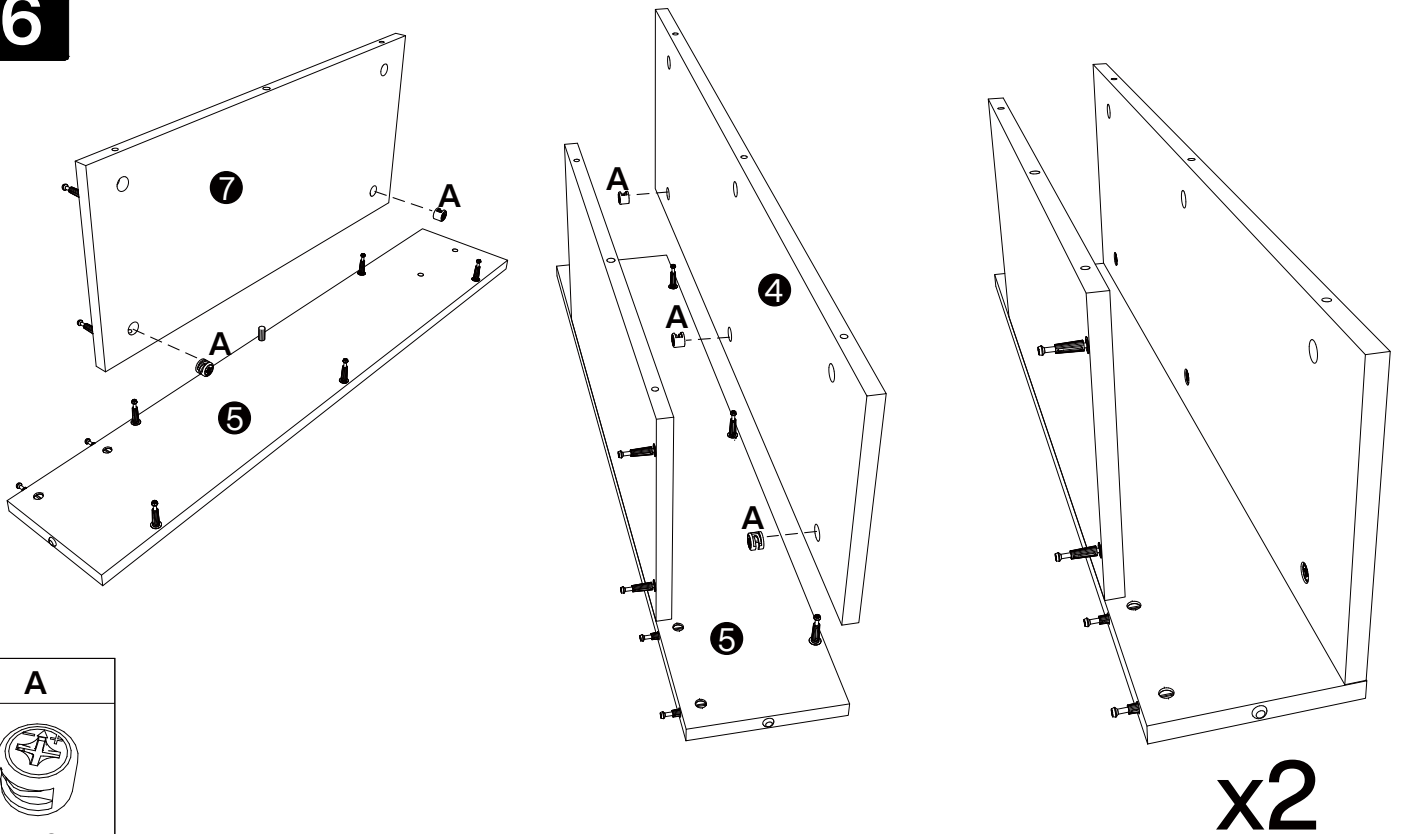

A

Ø15x12mm
10 pcs

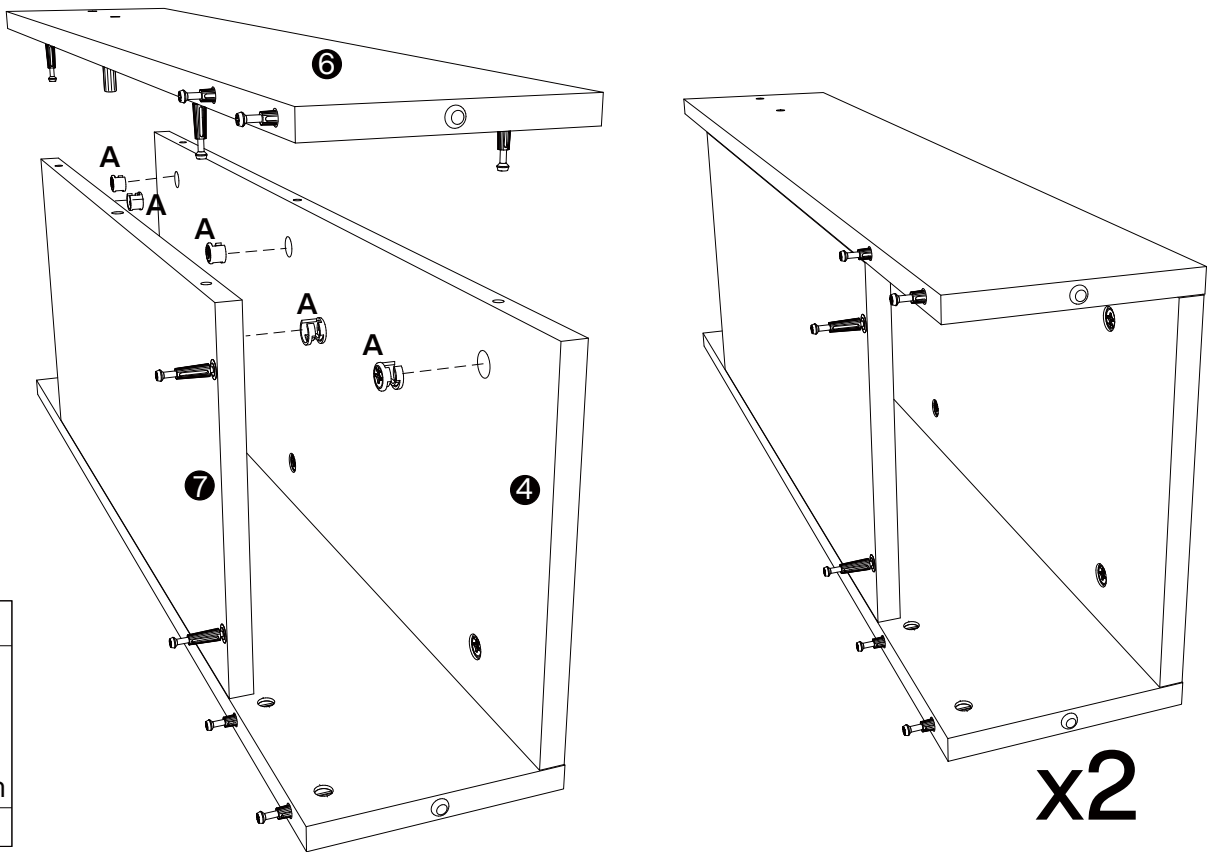

7

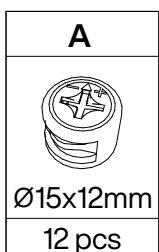
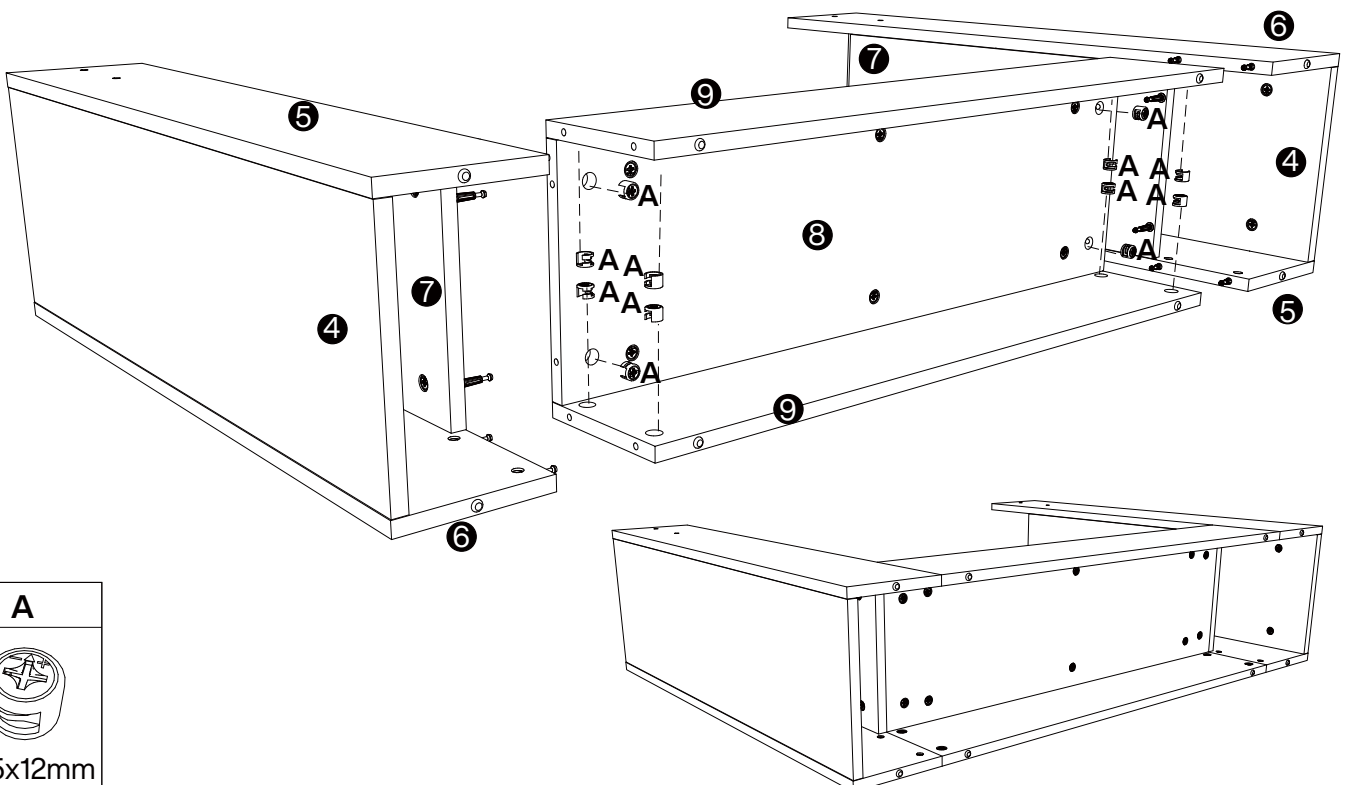

8



9

B

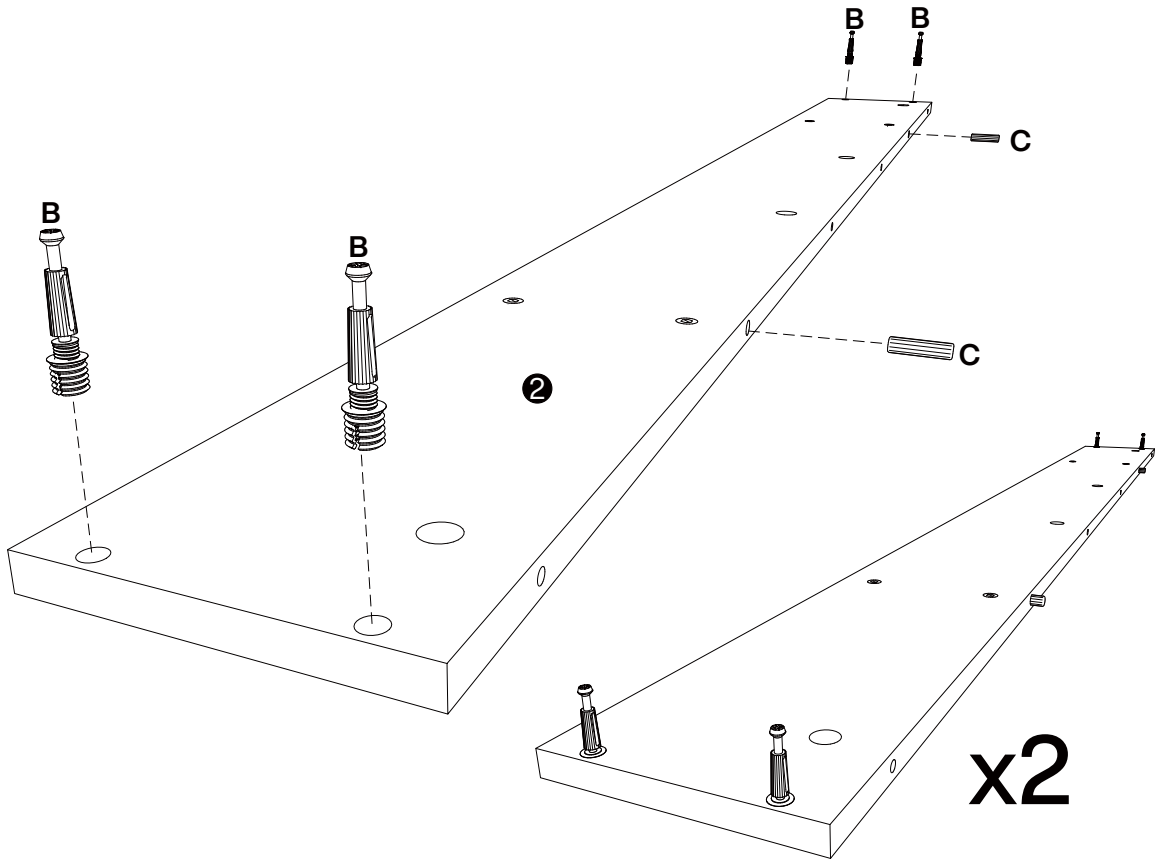
M6x40mm
8 pcs
C

Ø8x30mm
4 pcs

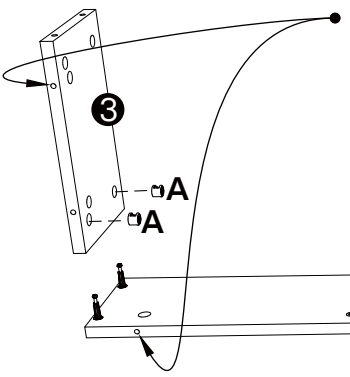

10

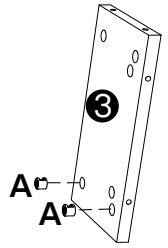

EN - Pay attention to the hole position
DE - Bitte achten Sie auf die Lochposition
IT - Prestare attenzione alla posizione del for
FR - Attention à la position du trou
ES - Por favor, preste atención a la posición del agujero.

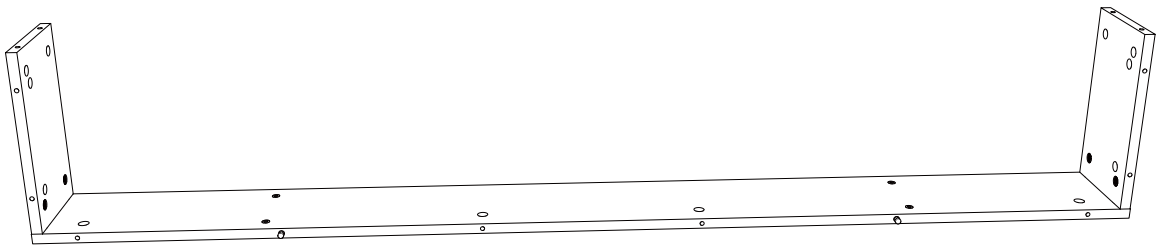

A

Ø15x12mm
4 pcs



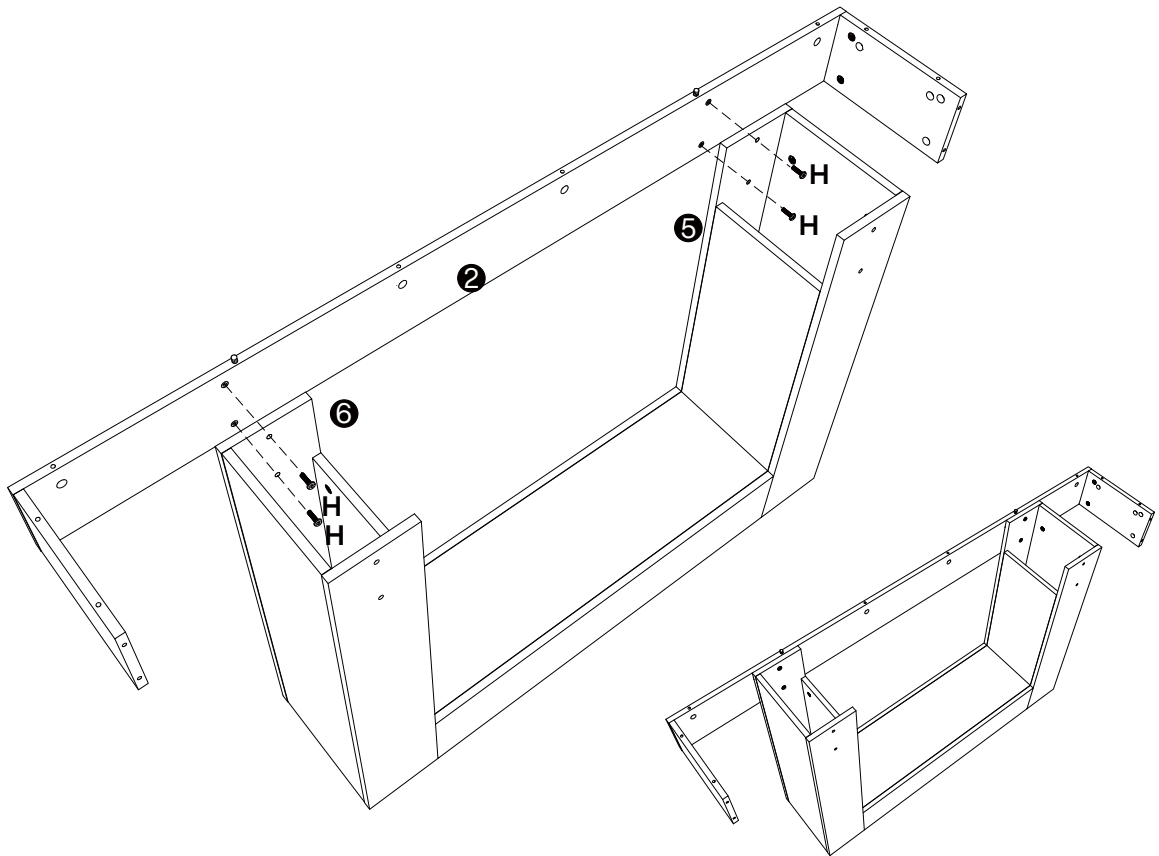

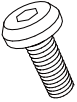
11

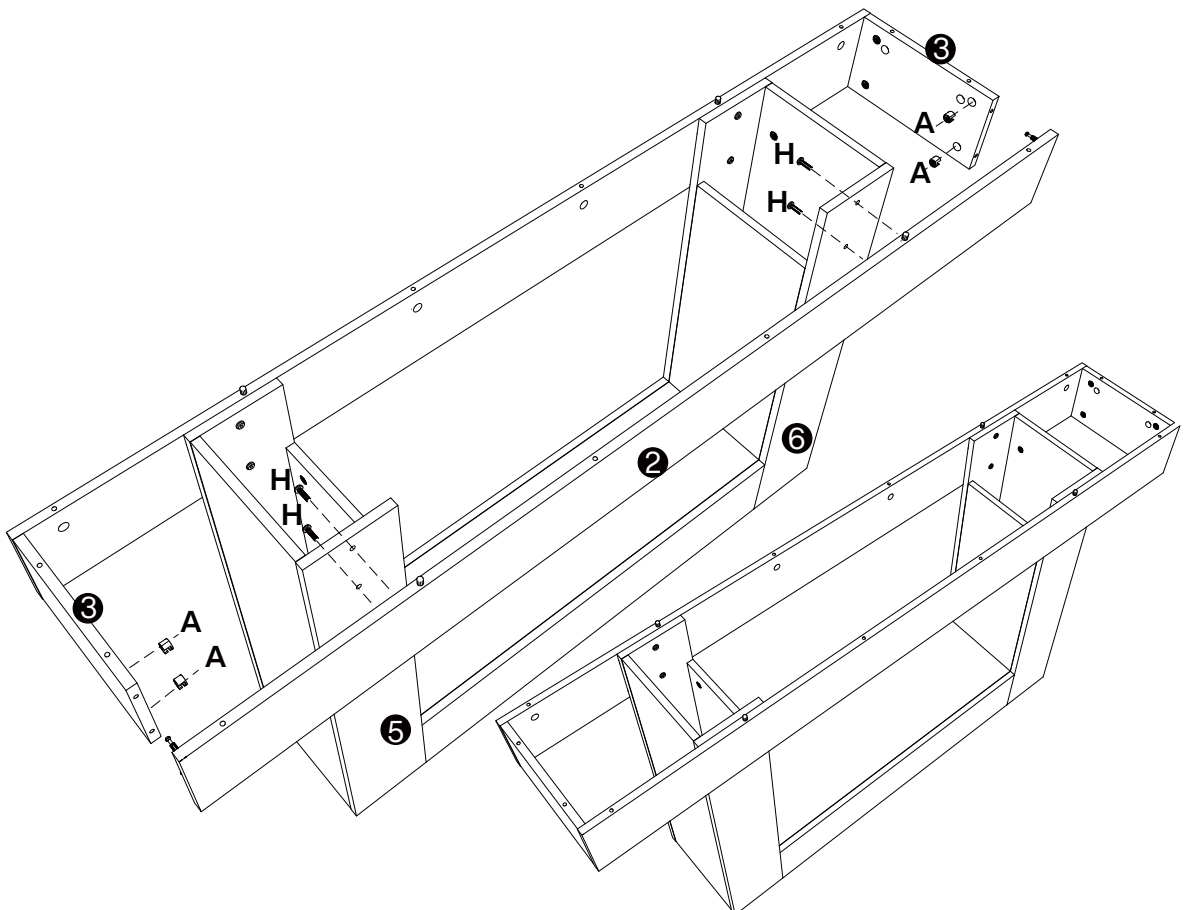

H

M6x25mm
4 pcs

12

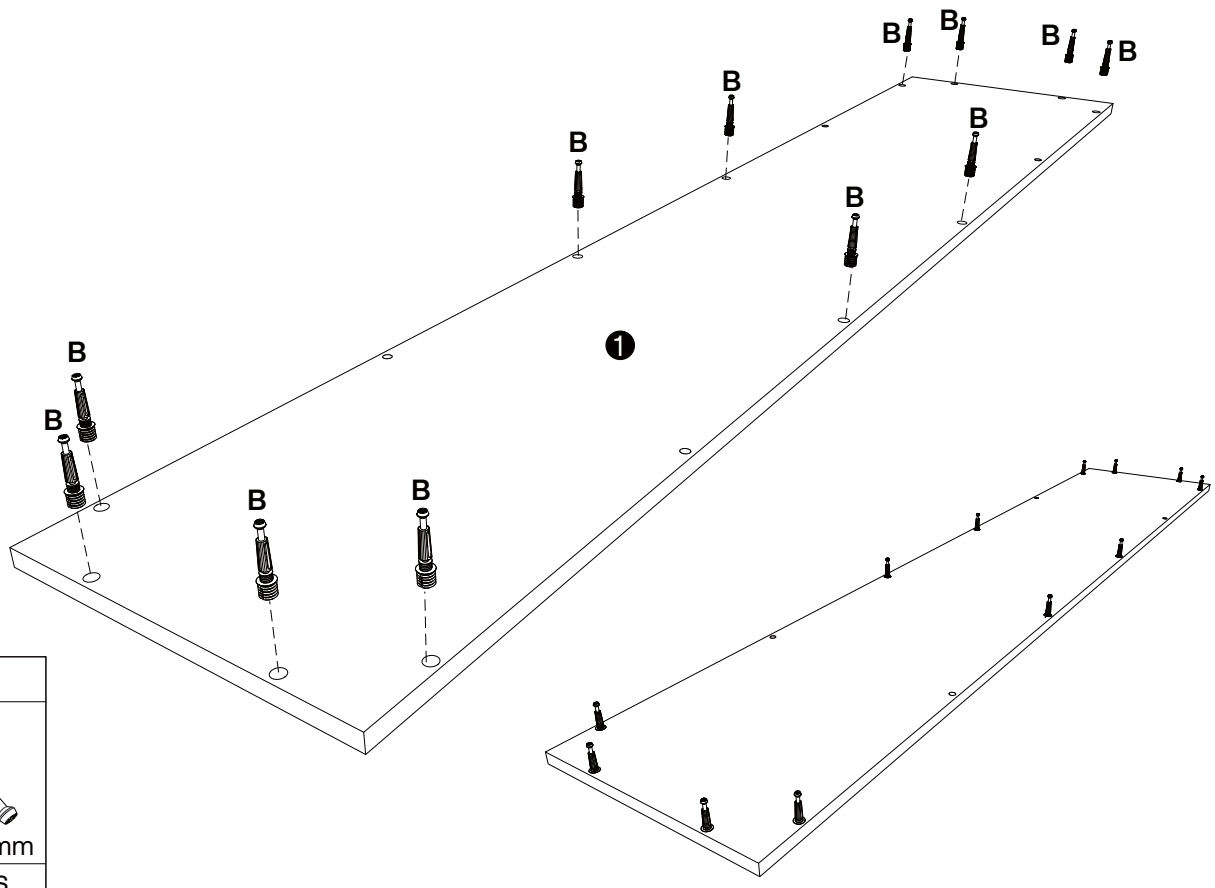

A

Ø15x12mm
4 pcs
H

M6x25mm
4 pcs

13



B

M6x40mm
12 pcs

14

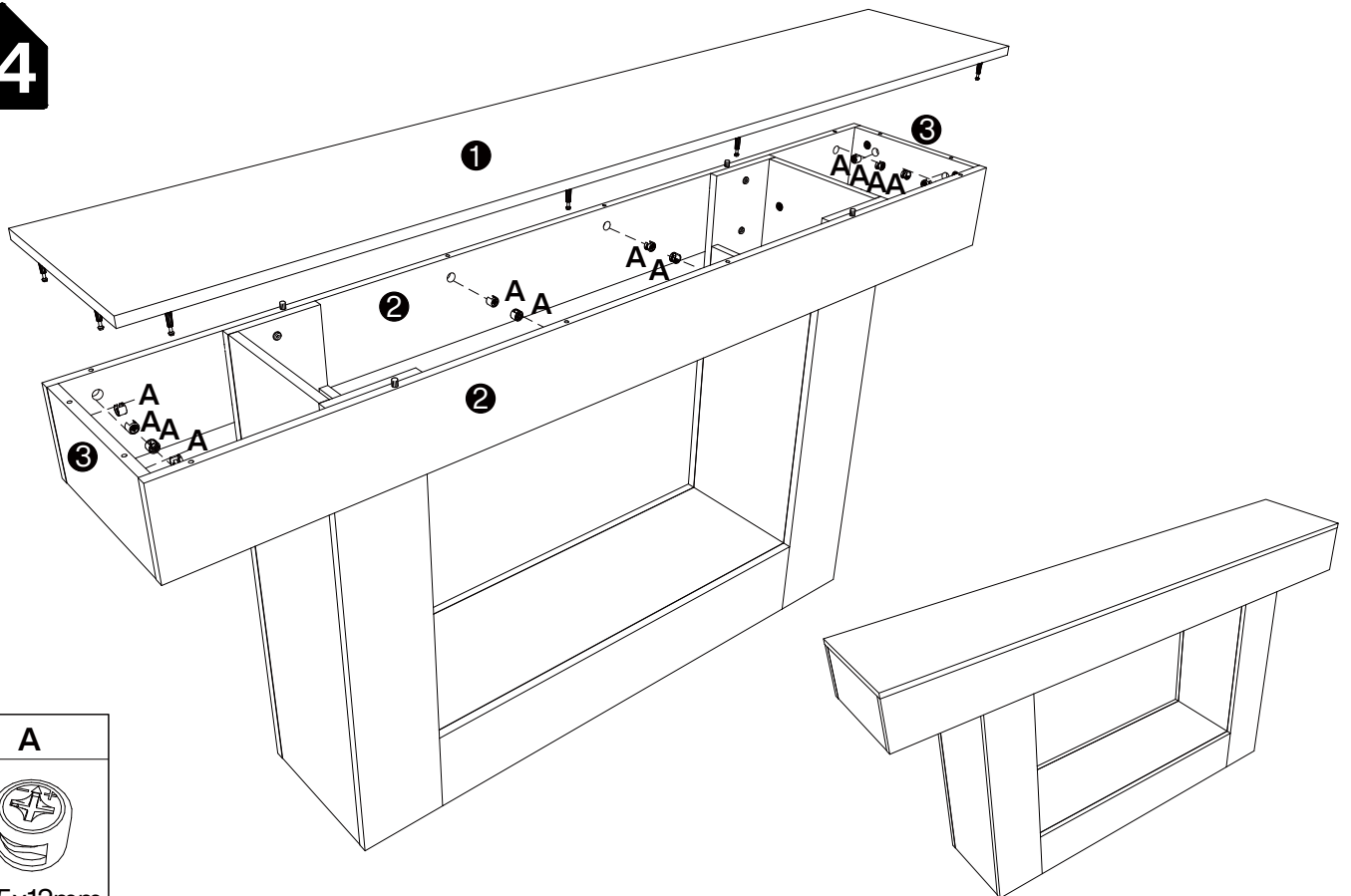

A

Ø15x12mm
12 pcs

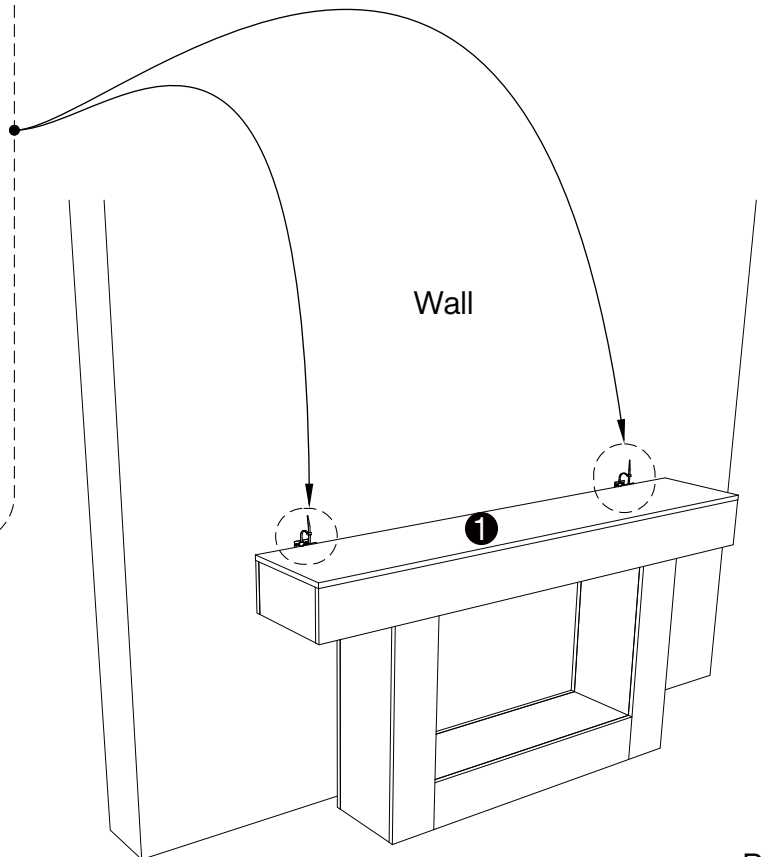
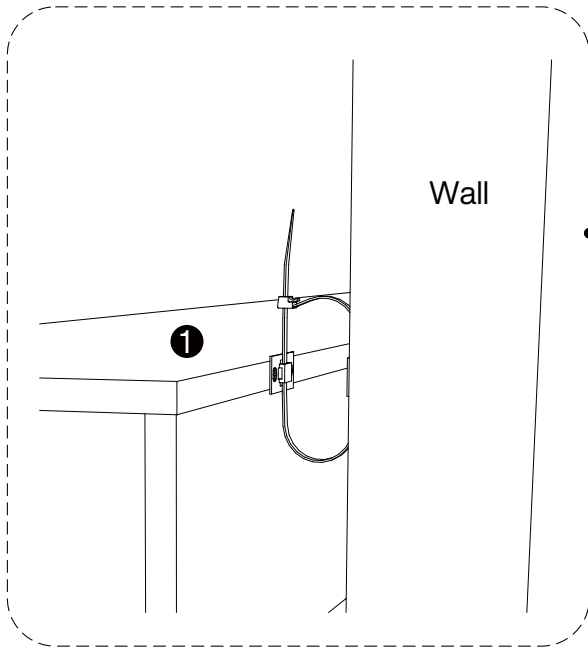
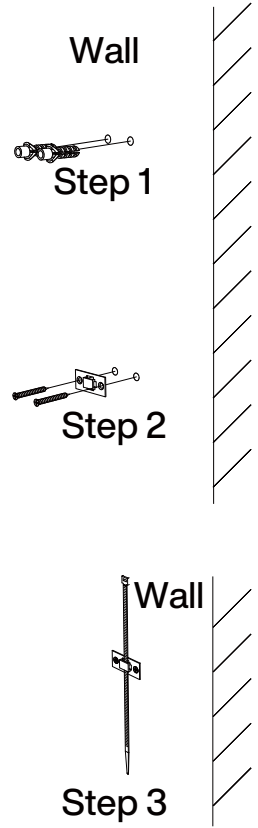
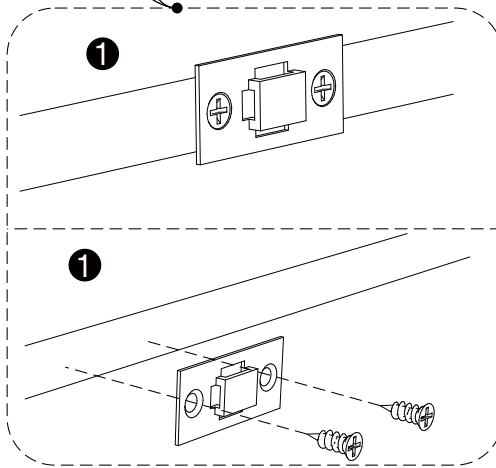
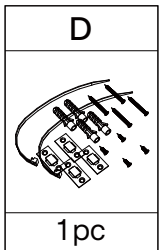
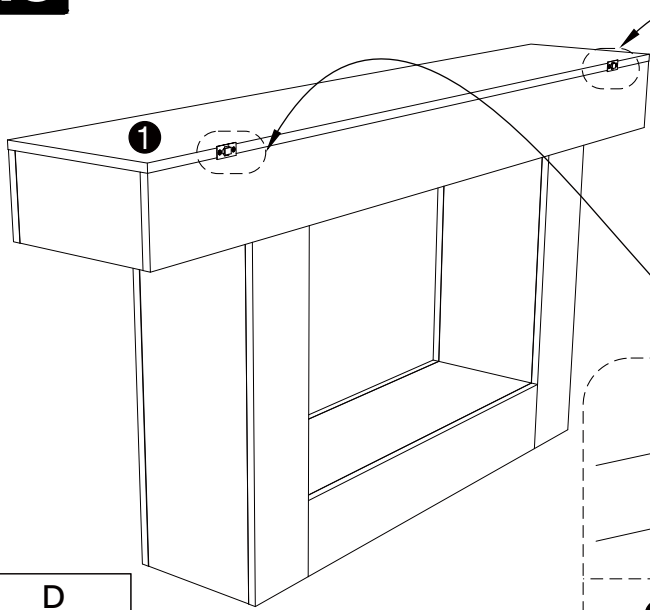
15

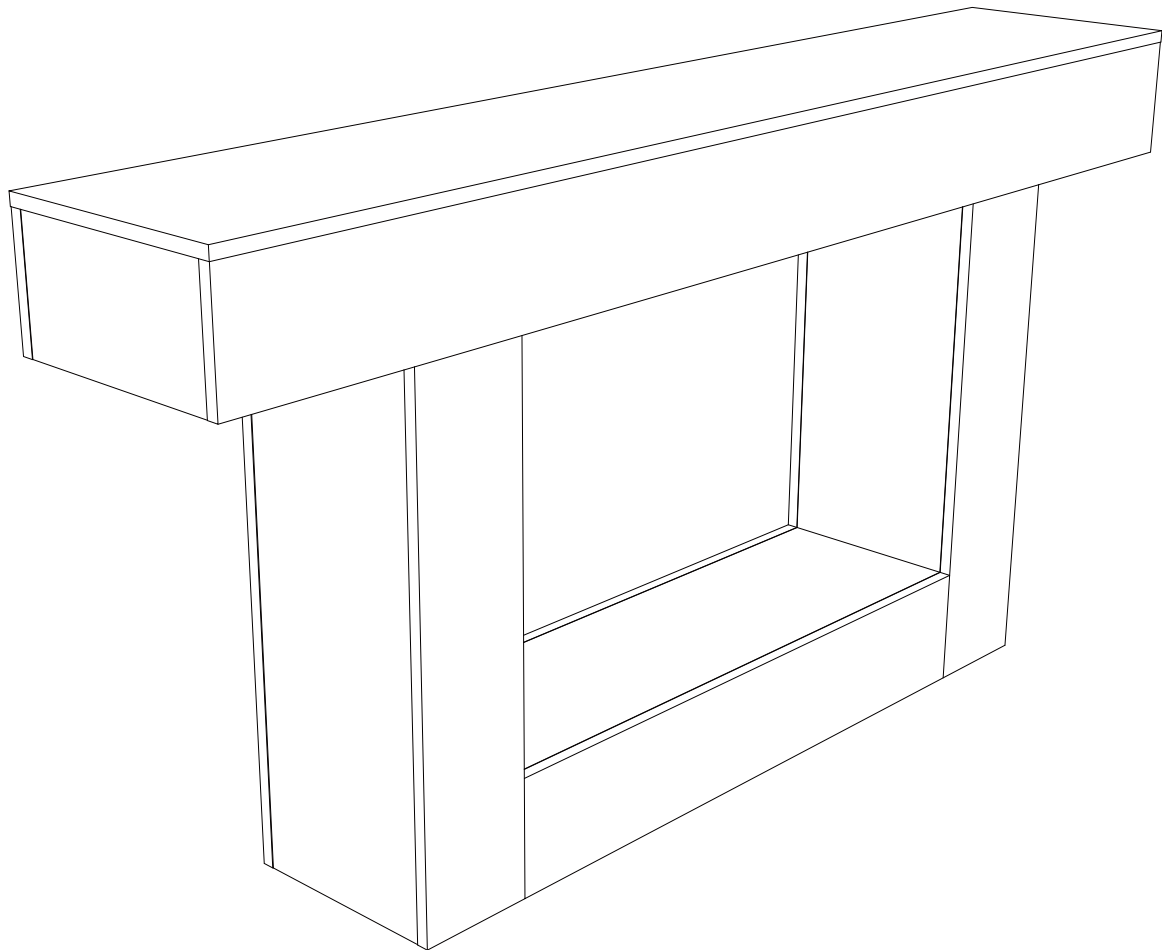



- EN** - Don't press hard on the table edge.
- DE** - Bitte drücken Sie nicht zu fest auf die Tischkante.
- IT** - Non premere con forza sul bordo del tavolo.
- FR** - N'appuyez pas trop fort sur le bord de la table.
- ES** - No presione demasiado el borde de la mesa.