

Please check contents **before** assembly. If any items are missing or damaged, **do not take the unit back to the store.**

**LOG CHAIR & LOVE SEAT COMPONENTS**

Preassembled Back

1 Left Front Leg 26" Long

1 Right Front Leg 26" Long

2 Back Legs 26" Long

Preassembled Seat

2 Chair Arms

2 Leg Braces

**NOTE: Cracks or Checks in logs are part of the natural beauty of cedar logs and should not be considered defects.**

**LOG CHAIR & LOVE SEAT HARDWARE**  
(Shown smaller than actual size)

Fourteen 2 1/2" screws

**TOOLS REQUIRED**

Rubber Mallet

Block of Wood & Hammer

7/16" socket or wrench

#2 Phillips Screwdriver

7/16" Socket

Optional power drill

**NOTE:**

- Read all instructions before starting.
- The two differences between the chair and the love seat are the length of the seat and back.
- Do not completely tighten any screws until the unit is fully assembled and setting on a level surface.
- Use a rubber mallet (or a block of wood between the hammer and the unit) to drive doweled ends into holes as far as possible.

**TIPS**

- A battery operated or electric drill will make assembly faster and easier.
- Use a good quality penetrating oil or wood deck sealer with a UV inhibitor & an anti-fungal. (Make sure product is intended for outdoor use.)
- If staining or finishing before assembling, tape off all dowel ends. (Finishes will cause the dowels to swell, making assembly difficult.)

**STEP 1** Lay assembled seat on floor. Insert dowel end of uprights on assembled back into holes on the back seat rail, adjust uprights in or out as needed to align properly. Do not tap on seat back with hammer.

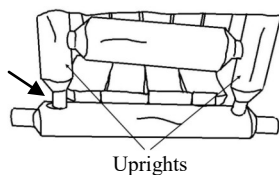

Tap uprights in or out until dowel drops into hole.

To keep the seat rail from splitting, lay the back on the floor and drive the seat onto the doweled ends by hitting on the bottom of the seat assembly.

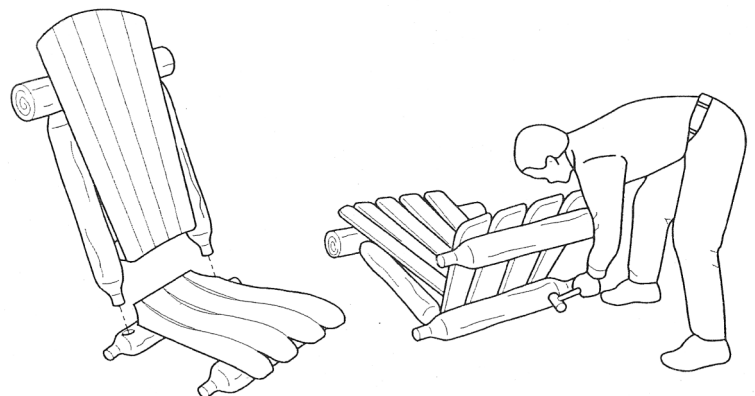

figure 1

STEP 2 Make a right leg set and a left leg set by inserting dowel end of back leg into angled hole of front leg. The drilled holes on each leg should face the same direction as shown in figure 2. Put arms onto legs by inserting dowel end of front legs into the hole in the arms. Drive arm onto leg assembly as far as possible.

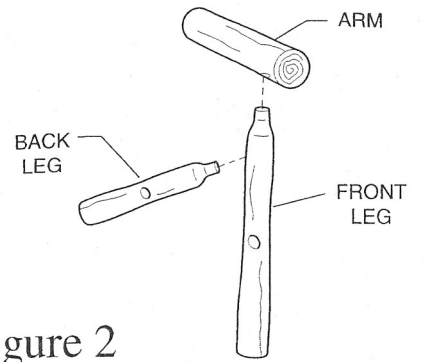

figure 2

STEP 3 Lay back and seat assembly on its side and insert dowel ends of seat rail into holes on leg sets. Drive legs on as far as possible. Turn assembly over and repeat procedure for the other side.

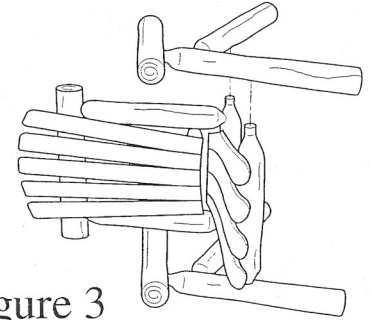

figure 3

STEP 4 Set chair in upright position on a level surface and when legs are in proper position, bring ARM in against UPRIGHT. Tighten the preinstalled lag screws into the pilot hole in the arm with a wrench or socket. Secure doweled joints in place with screws perpendicular to the doweled ends as shown in figure 4 and figure 6. Repeat procedure for other side.

STEP 5 Tilt chair back and screw a brace on each side of front leg to chair bottom as shown in figure 5.

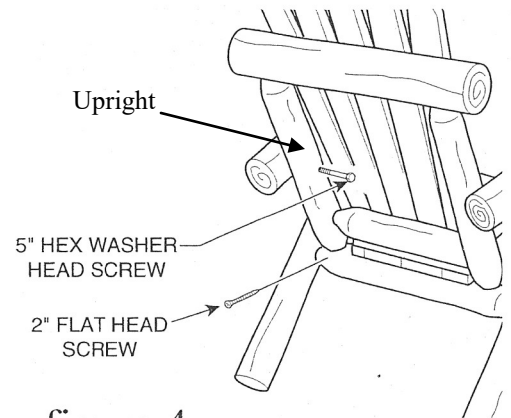

figure 4

STEP 6 Set unit on a level surface and tighten down all lag screws firmly to secure unit. Secure all dowel joints in place with screws perpendicular to the doweled end as shown in figure 6.

Your chair is now assembled and ready for finish or immediate use.

Check all joints for tightness before and during each usage season.

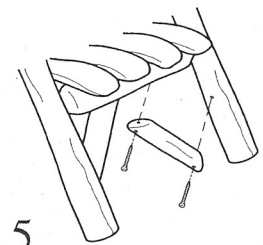

figure 5

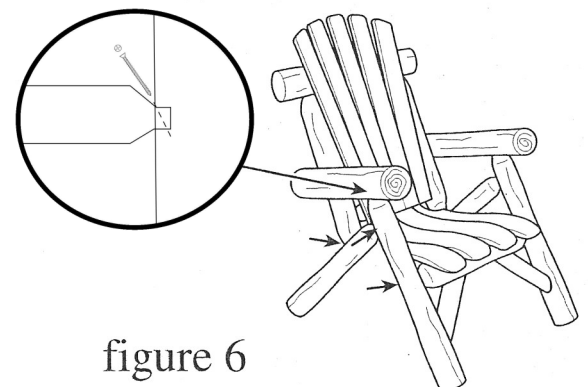

figure 6