

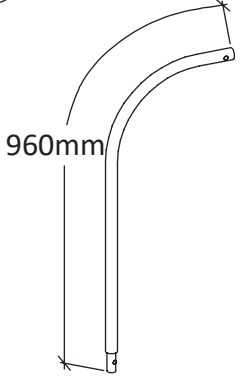

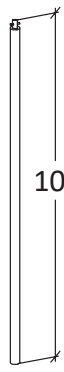

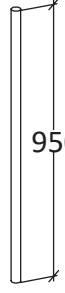

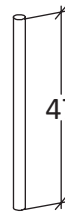

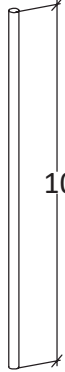
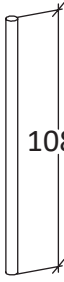

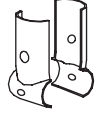
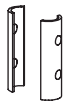
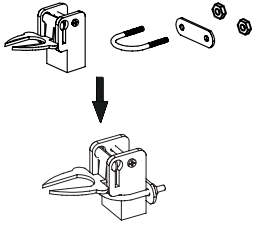
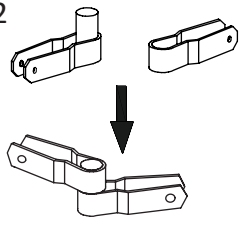
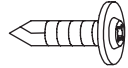

<p>① x8</p>  <p>960mm</p> <p><math>\frac{960}{37.8}</math></p>	<p>② x29</p>  <p>1050mm</p> <p><math>\frac{1050}{41.3}</math></p>	<p>③ x11</p>  <p>950mm</p> <p><math>\frac{950}{37.4}</math></p>	<p>④ x2</p>  <p>475mm</p> <p><math>\frac{475}{18.7}</math></p>
<p>⑤ x1</p>  <p>1000mm</p> <p><math>\frac{1000}{39.4}</math></p>	<p>⑦ x6</p>  <p>1080mm</p> <p><math>\frac{1080}{42.5}</math></p>	<p>Ax2</p>  <p>1050mm</p> <p><math>\frac{1050}{41.3}</math></p>	<p>Bx1</p>  <p>395mm</p> <p><math>\frac{395}{15.6}</math></p>
<p>Cx28</p> 	<p>Dx40</p> 	<p>Ex1</p> 	<p>Fx1</p> 
<p>Gx2</p> 	<p>Hx38</p>  <p>M4x <math>\frac{16}{0.6}</math></p>	<p>Ix4</p>  <p>M10x <math>\frac{40}{1.6}</math></p>	<p>Jx42</p>  <p>M6x <math>\frac{35}{1.4}</math></p>
<p>Kx6</p>  <p><math>\frac{300}{11.8}</math></p>	<p>K1x3</p>  <p><math>\frac{500}{20.0}</math></p>	<p>Lx1</p> 	<p>Mx1</p> 
<p>Nx1</p> 	<p>Ox1</p> 	<p>Px2</p> 	

1 x2

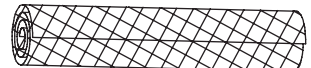

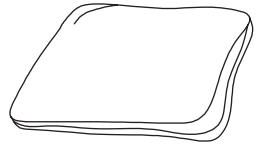
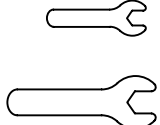
2 x2

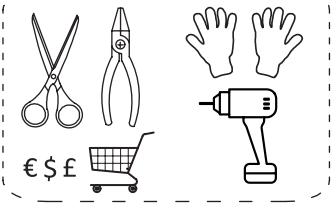
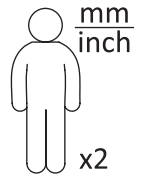
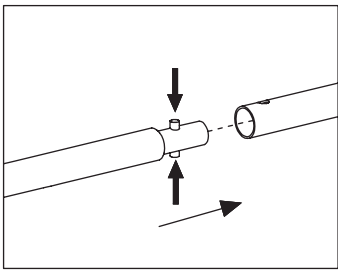
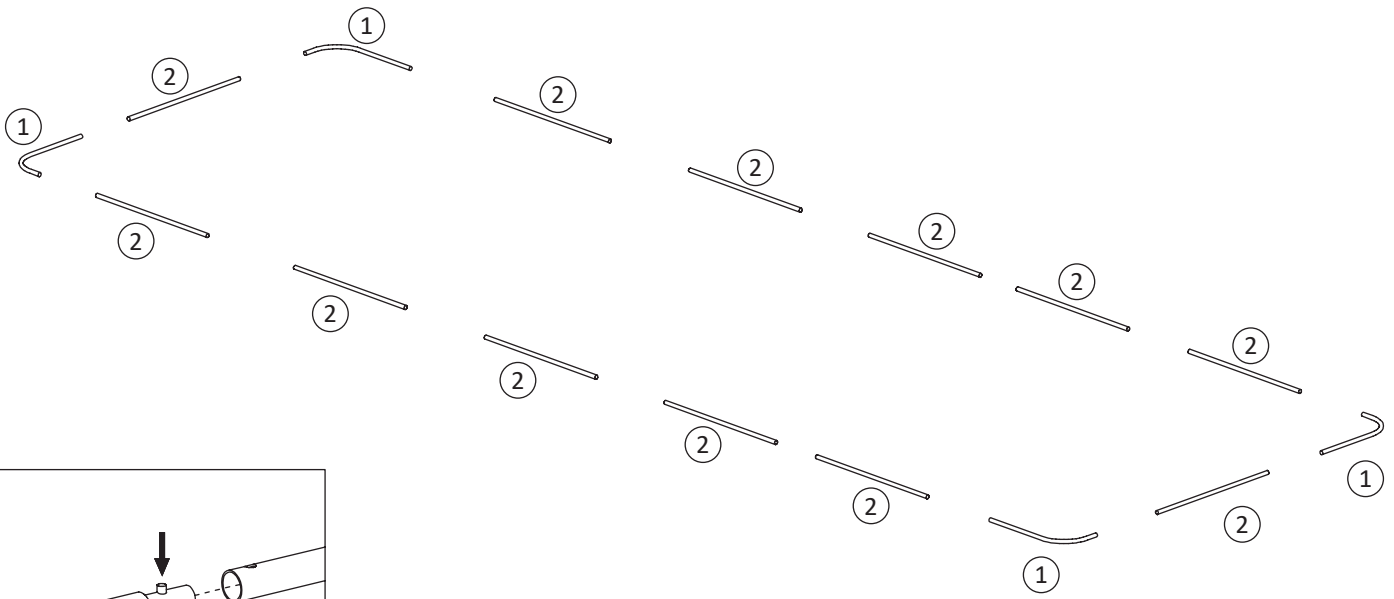
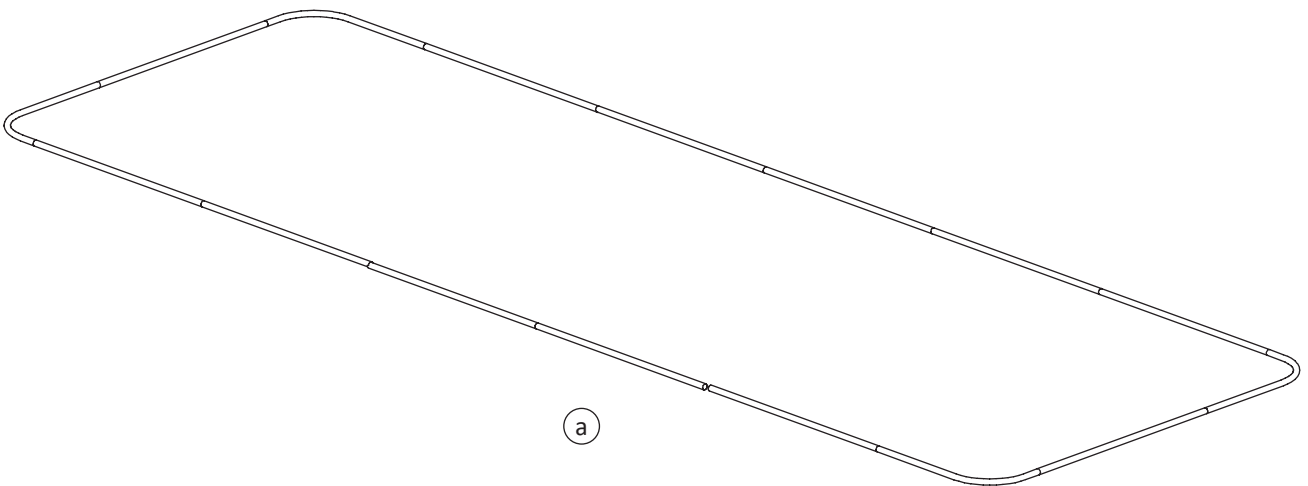

3

Jx11 

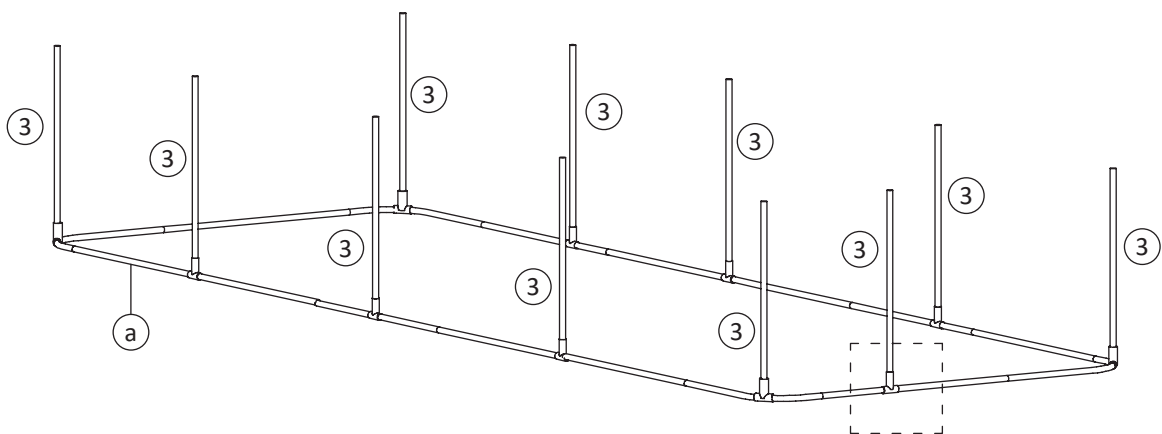

x11

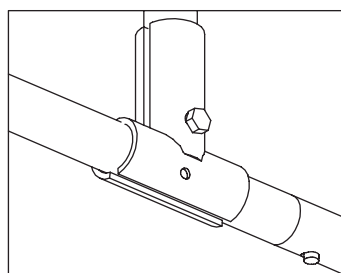
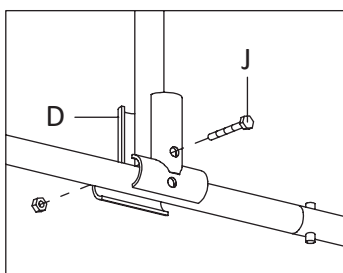

4

Jx11 

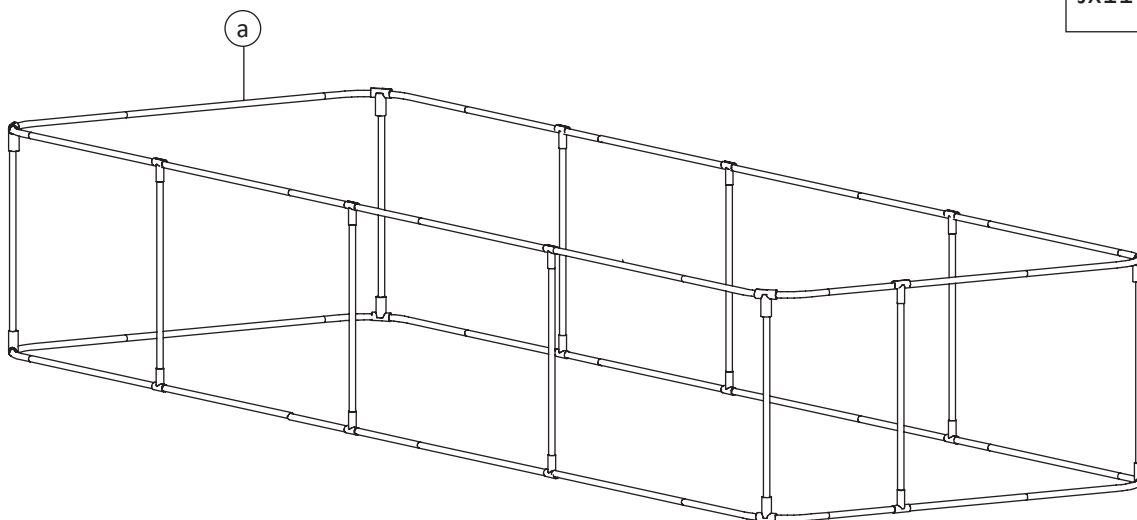

x11

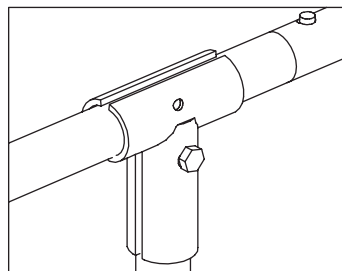
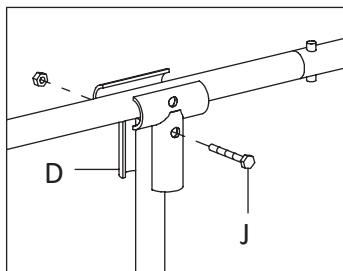

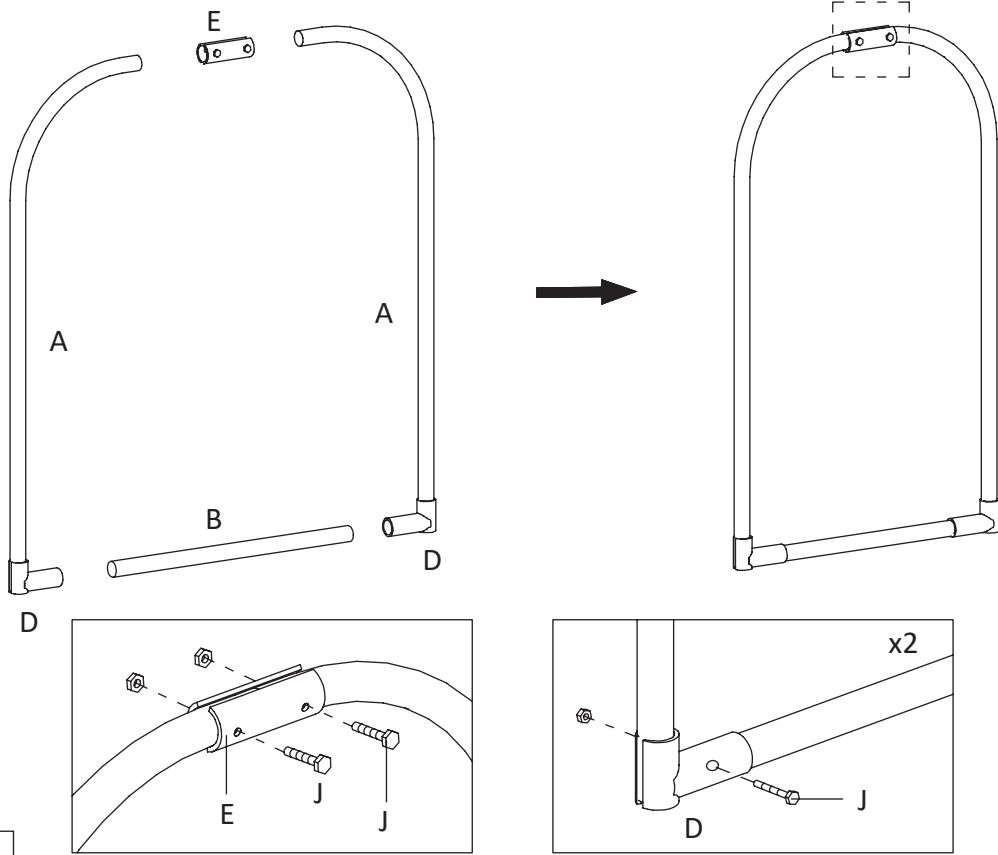

5



Jx4  

6

Ix4   Hx6 

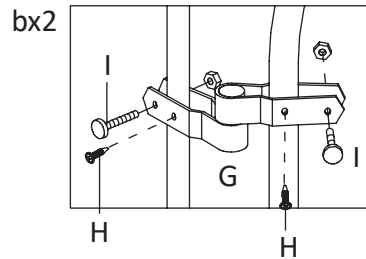
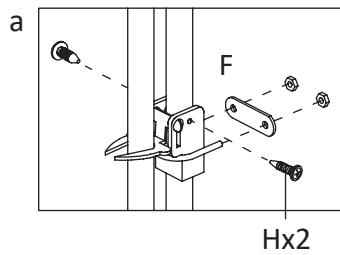
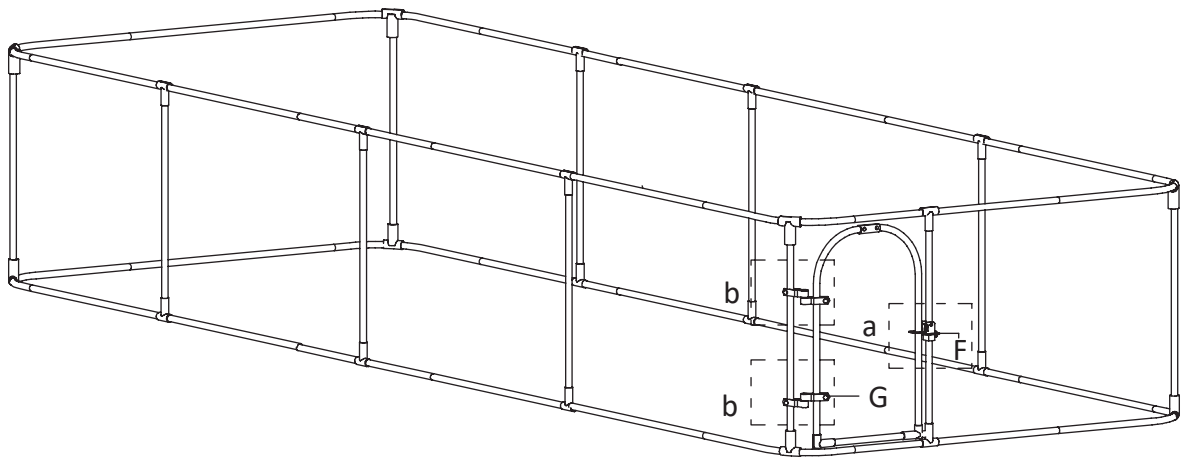

7

Jx2 

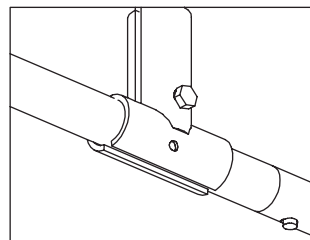
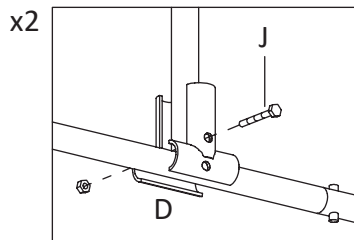
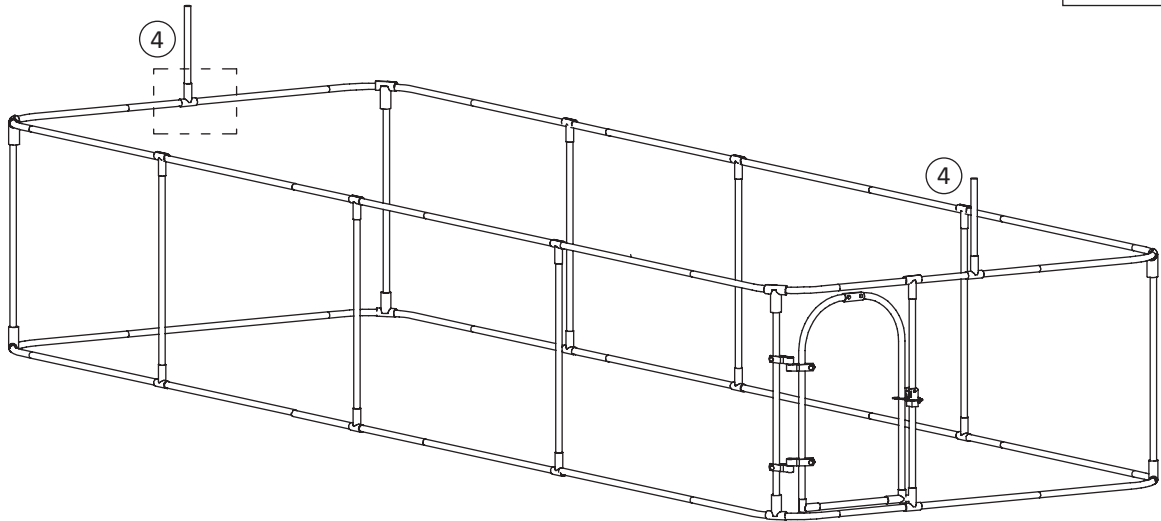

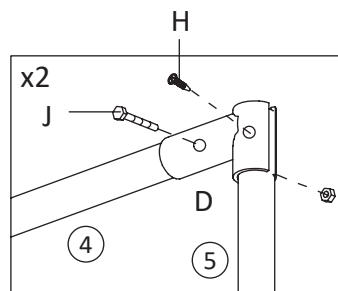
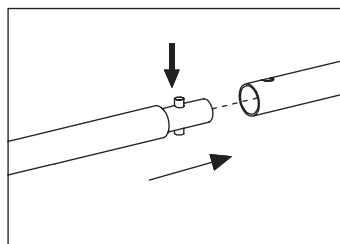
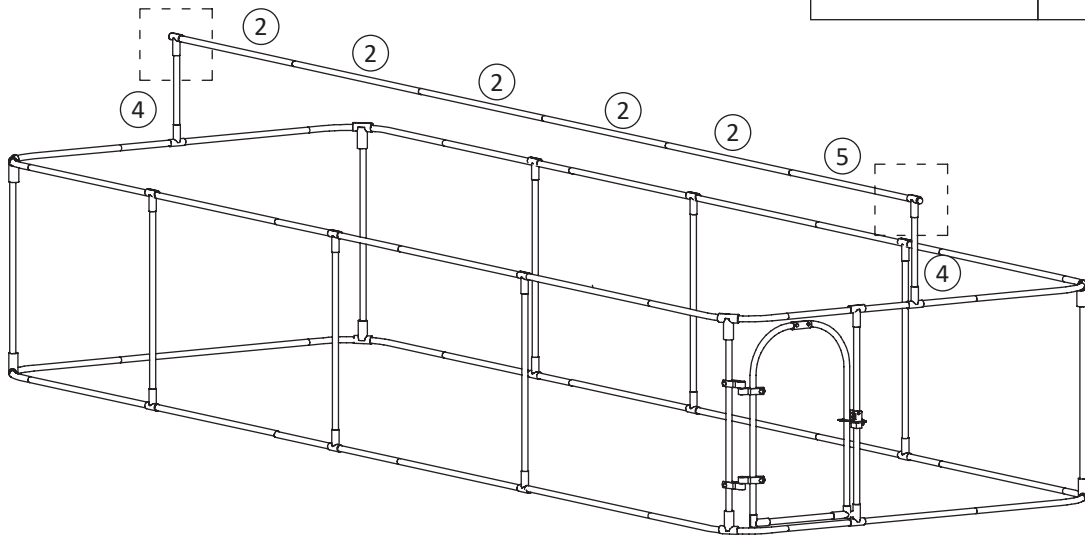

8

Jx2  Hx2 

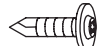

9

Jx12   Hx30 

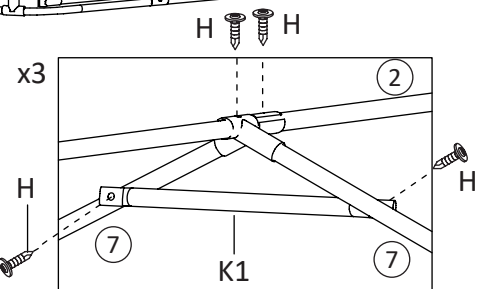
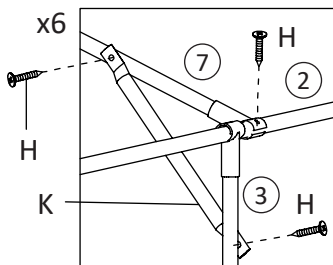
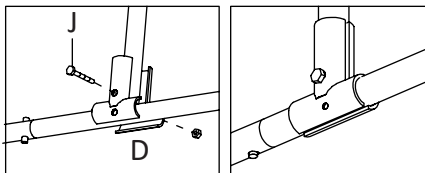
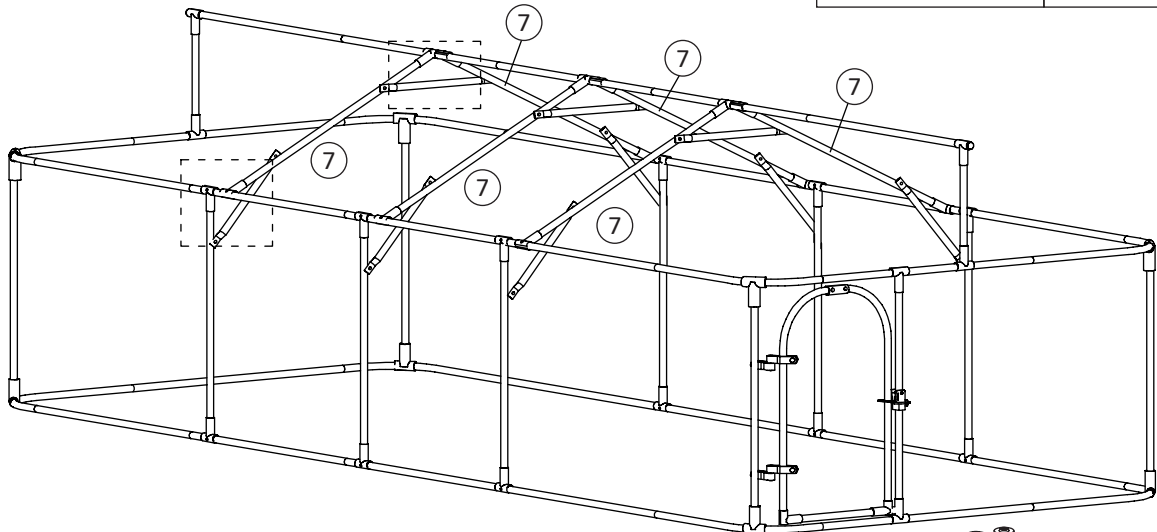

10

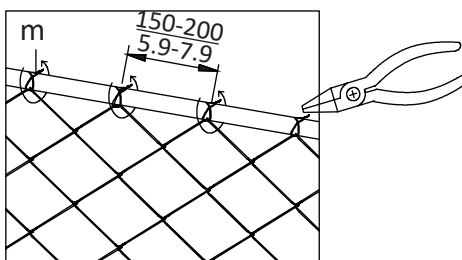
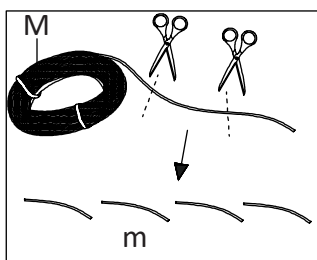
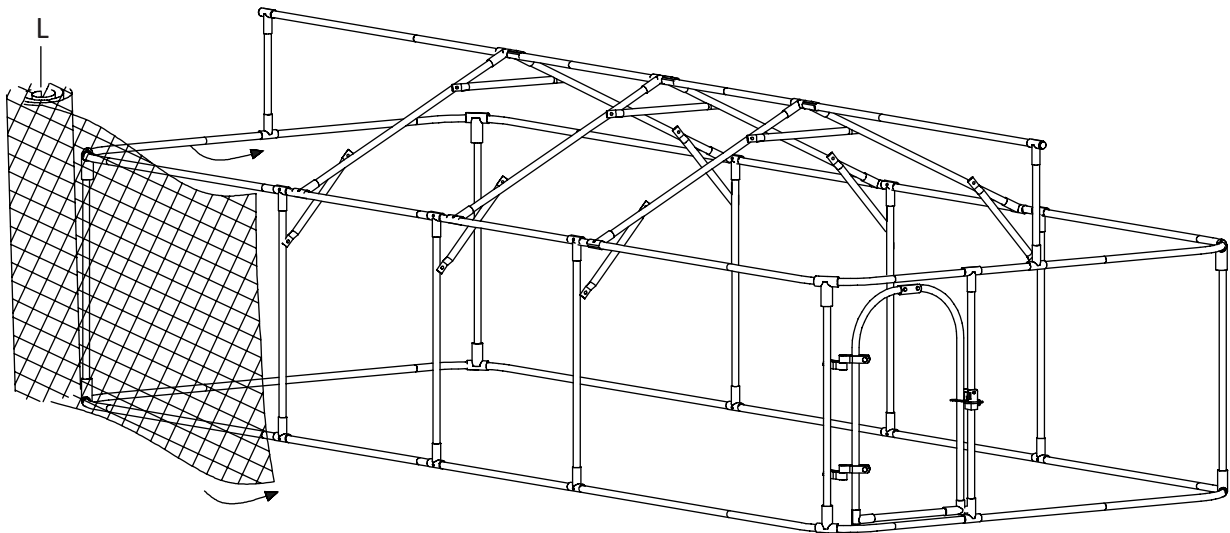

11

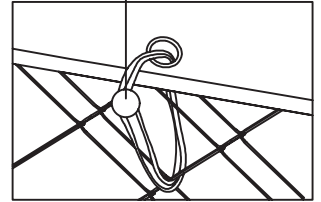
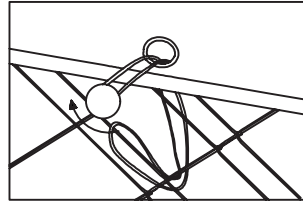
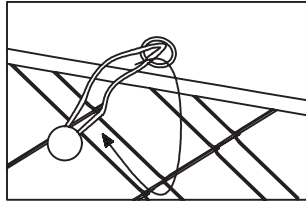
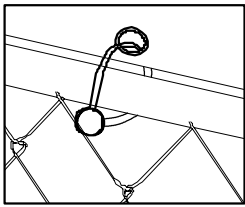
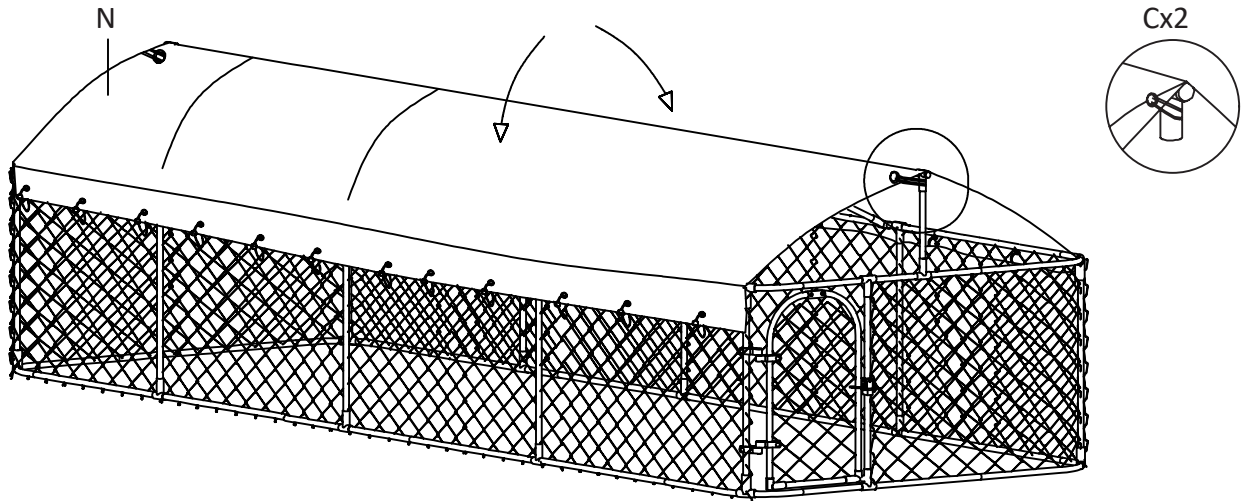

Cx26

12

Px2

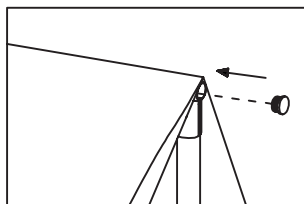
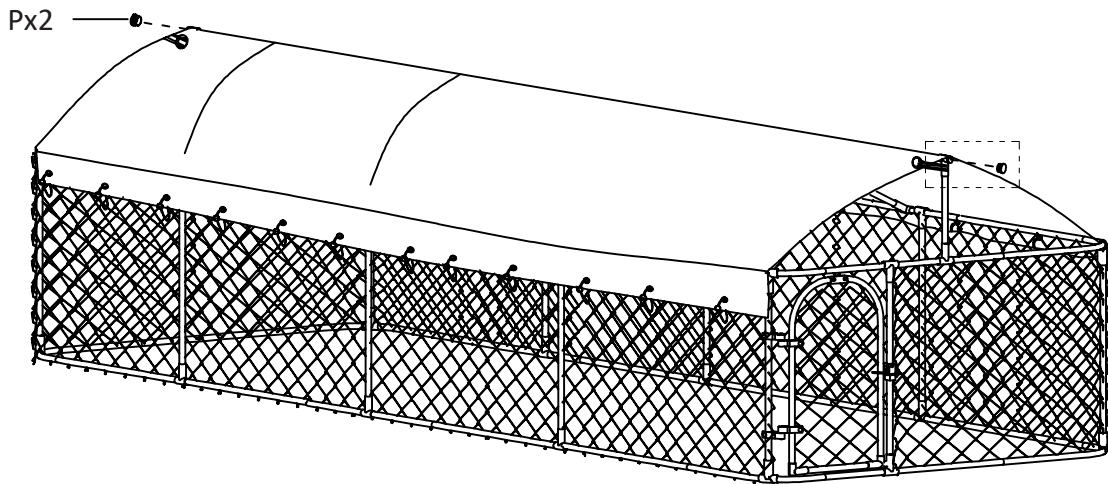

## EN

### Warning and personal safety

When assembling or cutting wire mesh, try using gloves or other protective materials to prevent stabbing your hands. You can also use pliers to flatten or bend the sharp edges or corners of the metal mesh inward or use protective materials such as tape to cover the sharp points.

## DE

### Warnung und persönliche Sicherheit

Tragen Sie Handschuhe oder andere Schutzmaterialien beim Zusammenbauen oder Schneiden von Maschendraht, um Schnittverletzungen an den Händen zu vermeiden. Sie können die scharfen Kanten oder Ecken des Metallgitters auch mit einer Zange abflachen oder nach innen biegen oder Schutzmaterialien wie Klebeband verwenden, um scharfe Spitzen abzudecken.

## FR

### Avertissement et sécurité personnelle

Lorsque vous assemblez ou coupez du grillage, essayez d'utiliser des gants ou d'autres matériaux de protection afin d'éviter de vous poigner les mains. Vous pouvez aussi utiliser des pinces pour aplatir ou plier vers l'intérieur les bords ou les coins pointus de la maille métallique ou utiliser des matériaux de protection tels que du ruban adhésif pour couvrir les points pointus.

## NL

### Waarschuwingen en persoonlijke veiligheid

Probeer bij het monteren of snijden van draadgaas handschoenen of ander beschermend materiaal te gebruiken, om te voorkomen dat u in uw handen steekt. U kunt ook een tang gebruiken om de scherpe randen of hoeken van het metaal gaas plat te maken of naar binnen te buigen, of u kunt beschermende materialen gebruiken om de scherpe punten te bedekken, bijvoorbeeld tape.

## IT

### Avvertenze e sicurezza personale

Durante l'assemblaggio o il taglio della rete metallica, provare a utilizzare guanti o altri materiali protettivi per evitare di ferirsi le mani. Si possono anche utilizzare delle pinze per appiattire o piegare i bordi taglienti o gli angoli della rete metallica verso l'interno oppure utilizzare materiali protettivi come il nastro adesivo per coprire le punte affilate.

## PL

### Ostrzeżenia i bezpieczeństwo

Podczas montażu lub przycinania siatki drucianej postaraj się nosić rękawice lub inny materiał ochronny, aby uniknąć zranienia rąk. Możesz także użyć szczypec, aby spłaszczyć lub zagiąć ostre krawędzie i rogi metalowej siatki, bądź użyć materiałów ochronnych takich jak taśma, aby osłonić ostre punkty.

## SE

### Varningar och personlig säkerhet

När du monterar eller skär trådnät, försök använda handskar eller annat skyddsmaterial för att förhindra att du sticker händerna. Du kan också använda tång för att platta eller böja de skarpa kanterna eller hörnen på metallnätet inåt eller använda skyddsmaterial som tejp för att täcka de vassa punkterna.

## ES

### Advertencias y seguridad personal

Al montar o cortar tela metálica, trate de usar guantes u otros materiales protectores para evitar pincharse las manos. También puede usar unos alicates para aplanar o doblar hacia dentro los bordes o esquinas afilados de la malla metálica o utilizar materiales protectores como cinta adhesiva para cubrir las puntas afiladas.

## DK

### Advarsel og personlig sikkerhed

Når du monterer eller klipper trådnæt, bør du bruge handsker eller andet beskyttelsesværn, så dine hænder ikke kommer til skade. Du kan også bruge en tang til at gøre de skarpe kanter flade eller til at bukke dem indad. Du kan ligeledes bruge beskyttende materiale såsom tape til at dække de skarpe punkter.

## NO

### Advarsel og personvern

Når du monterer eller skjærer trådnett, skal du bruke vernehansker eller andre beskyttende materialer for å unngå å stikke hendene. Du kan også bruke en tang til å flate ut eller bøye de skarpe kantene eller hjørnene på metallnettet innover eller bruke beskyttende materialer som tape for å dekke de skarpe punktene.

## PT

### Avisos e segurança pessoal

Ao montar ou ao cortar a rede de arame, tente usar luvas ou outros materiais de proteção para evitar perfurar as mãos. Também pode utilizar alicates para achatar ou dobrar as pontas ou os cantos afiados da rede de metal para dentro. Pode ainda optar por outros materiais de proteção, tais como fita adesiva para tapar os pontos afiados.

## RO

### Avertisment și siguranță personală

Când asamblați sau tăiați plasele de sârmă, încercați să folosiți mănuși sau alte materiale de protecție pentru a preveni înțeparea mâinilor. De asemenea, puteți folosi clești pentru a aplatiza sau îndoi marginile ascuțite sau colțurile plasei metalice spre interior sau puteți utiliza materiale de protecție, cum ar fi bandă, pentru a acoperi punctele ascuțite.

## SI

### Opozorilo in osebna varnost

Pri sestavljanju ali rezanju žične mreže poskusite uporabiti rokavice ali druge zaščitne materiale, da si ne zbodete rok. Ostre robove ali vogale kovinske mreže lahko sploščite ali upognete navznoter s kleščami ali pa ostre točke prekrijete z zaščitnim materialom, kot je trak.

## HU

### Figyelmeztetés és személyi biztonság

A drótháló összeszerelésekor vagy vágásakor viseljen kesztyűt vagy más védőeszközt, hogy ne sérüljön meg a kezét. A fémháló éles széleinek vagy sarkainak befelé lapításához vagy hajlításához fogót használhat, de az éles pontokat védőanyaggal, például szalaggal le is takarhatja.

## CZ

### Varování a osobní bezpečnost

Při montáži nebo stříhání drátěného pletiva používejte rukavice nebo jiné ochranné pomůcky, abyste si neporanili ruce. Ostré hrany nebo rohy kovového pletiva můžete také vyrovnat nebo ohnout dovnitř pomocí kleští, popřípadě použít k zakrytí ostrých bodů ochranné materiály, jako je např. páska.

## SK

### Varovania a osobná bezpečnosť

Aby ste si pri montáži alebo rezaní drôteného pletiva neporezali ruky, mali by ste použiť rukavice alebo iné ochranné materiály. Môžete tiež použiť kliešte na sploštenie alebo ohnutie ostrých hrán alebo rohov kovovej siete dovnútra. Alebo na zakrytie ostrých bodov môžete použiť ochranné materiály, ako je napríklad páska.

## IS

### Viðvaranir og persónulegt öryggi

Þegar þú setur vírnet saman eða klippir það, notaðu þá hanska eða annan hlífðarbúnað til að koma í veg fyrir meiðsli á höndum. Þú getur einnig notað tangir til að fletja eða beygja skarpar brúnir og horn á málmnetinu inn á við eða notað varnarefni á borð við límband til að hylgja skarpa fleti.