

**FloWise® DUAL FLUSH ELONGATED TOILET
WITH SEAT**

2479.216

- Vitreous china
- Meets definition for HET (High Efficiency Toilet)
- Low-consumption Dual Flush Toilet
- Qualifies in LEEDS Program
- Full flush 6.0 Lpf/1.6 gpf,
Partial flush 3.0 Lpf/0.8 gpf
- Elongated wash down bowl
- Internal trapway fully-glazed,
2-1/4" (57mm) trapway
- Concealed trapway bowl
- Chrome-plated top mounted push
button actuator
- Sanitary Dam on bowl
- Includes color-matched plastic seat and cover
- 100% factory flush tested
- 2 color matched bolt caps
- 2 year warranty

2479.516

- Same as above, except with tank
with Aquaguard liner

Separate Component Parts:

- 3067.216** Elongated Bowl
- 4035.216** Unlined Tank
- 4035.516** Tank with Aquaguard Liner

Alternate Tank Configurations Available:

- 4035.516** Lined Tank

Nominal Dimensions:

31-1/4" x 17" x 30-1/8"
(794 x 432 x 765mm)

Fixture and seat only, supply by others

Compliance Certifications -

Meets or Exceeds the Following Specifications:

- ASME A112.19.2M
- CSA B45 series
- City of Los Angeles Supplemental
Purchase Specification
- UNAR
- US EPA WaterSense Specification for HETS

To Be Specified:

- Color: White
- Supply with stop:

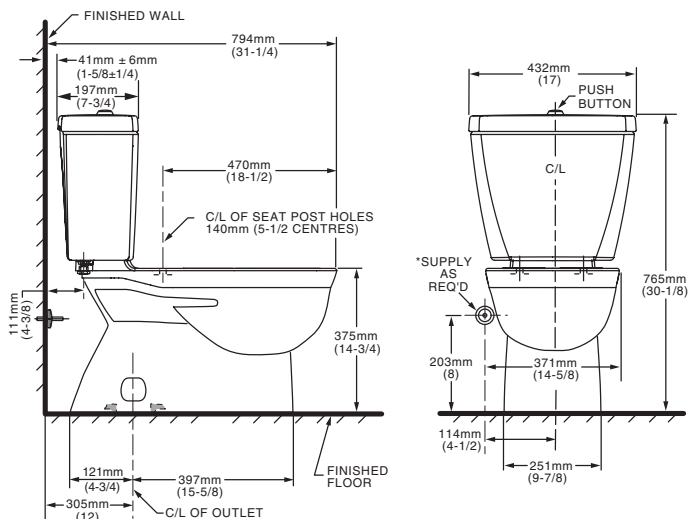

NOTES:

THIS TOILET IS DESIGNED TO ROUGH-IN AT A MINIMUM DIMENSION OF 305MM (12") FROM FINISHED WALL TO C/L OF OUTLET. SUPPLY NOT INCLUDED WITH FIXTURE AND MUST BE ORDERED SEPARATELY.

* DIMENSION SHOWN FOR LOCATION OF SUPPLY IS SUGGESTED. FOR ADDITIONAL INFORMATION REFER TO INSTALLATION INSTRUCTIONS SUPPLIED.

IMPORTANT: Dimensions of fixtures are nominal and may vary within the range of tolerance established by ANSI Standard A112.19.2 These measurements are subject to change or cancellation. No responsibility is assumed for use of superseded or voided pages

