

Ⓐ 1X Seat Back With Armrest

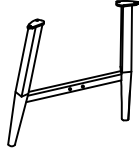

Ⓑ 1X Seat Plate&Front Legs



Ⓒ 1X Back Legs



Ⓓ 1X Support Tube

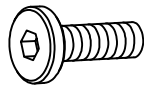

Ⓔ 6X Screw M6X18

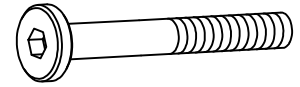

Ⓕ 4X Screw M6X50



Ⓖ 10X Washer



Ⓖ 10X Plastic Cap







Ⓗ 1X Seat Cushion

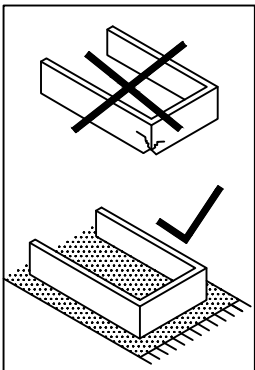

Ⓙ 1X Hex Wrench





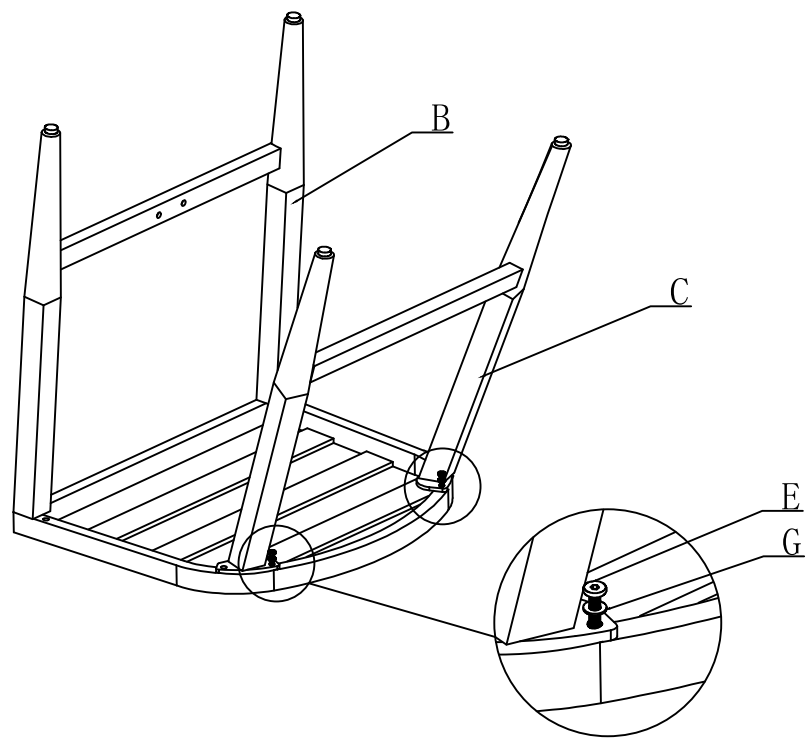

1

- (B) 1X 
- (C) 1X 
- (E) 2X M6X18 
- (G) 2X 
- (J) 1X 

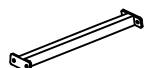



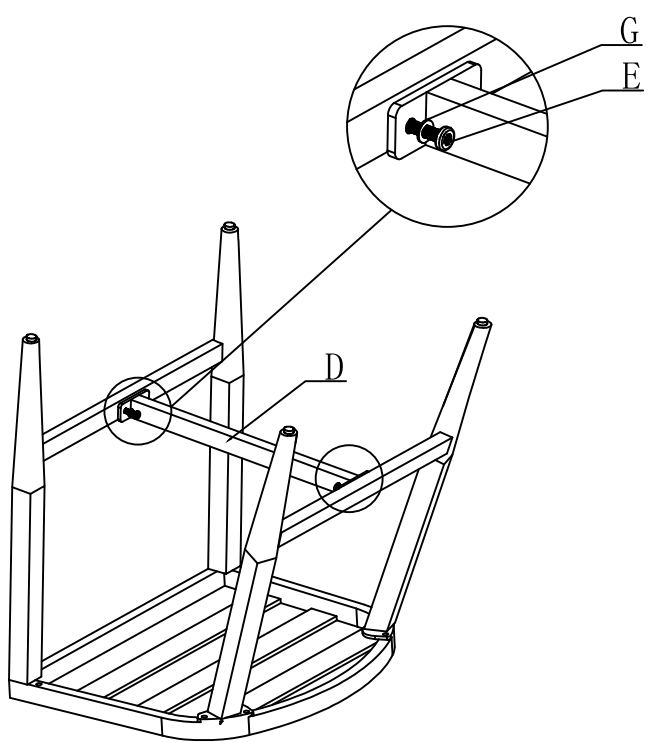

Attach Part #C to Part #B with 2 washers #G and 2 screws #E.

- (D) 1X 
- (E) 4X M6X18 
- (G) 4X 
- (J) 1X 



Connect Part #B and Part #C with Part #D, then secure with 4 washers #G and 4 screws #E.

- (A) 1X 
- (F) 4X M6X5 
- (G) 4X 
- (J) 1X 

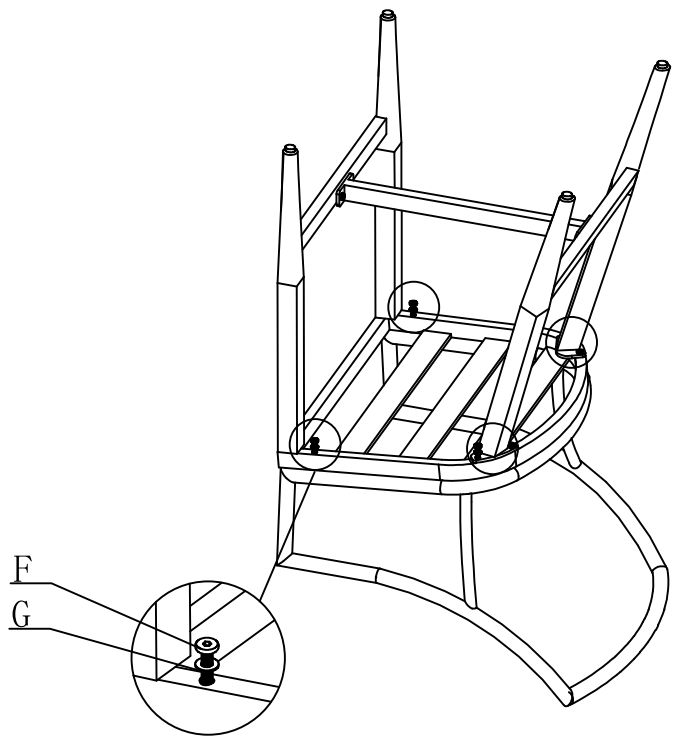

Align Part #A with the seat plate, then secure with 4 washers #G and 4 screws #F.

- (H) 1 X 

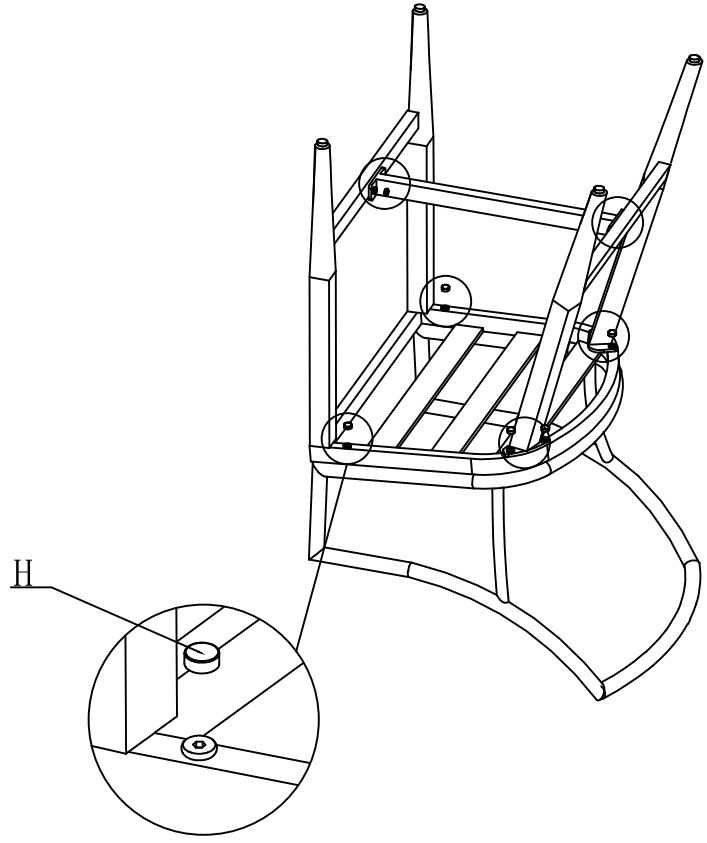

Make sure all 10 screws are tightened, then cover with 10 plastic caps #H.



Ⓡ 1X

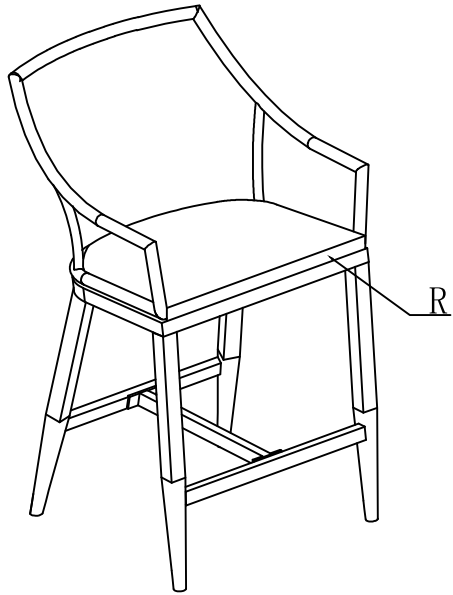

Put Part #R on the seat plate.

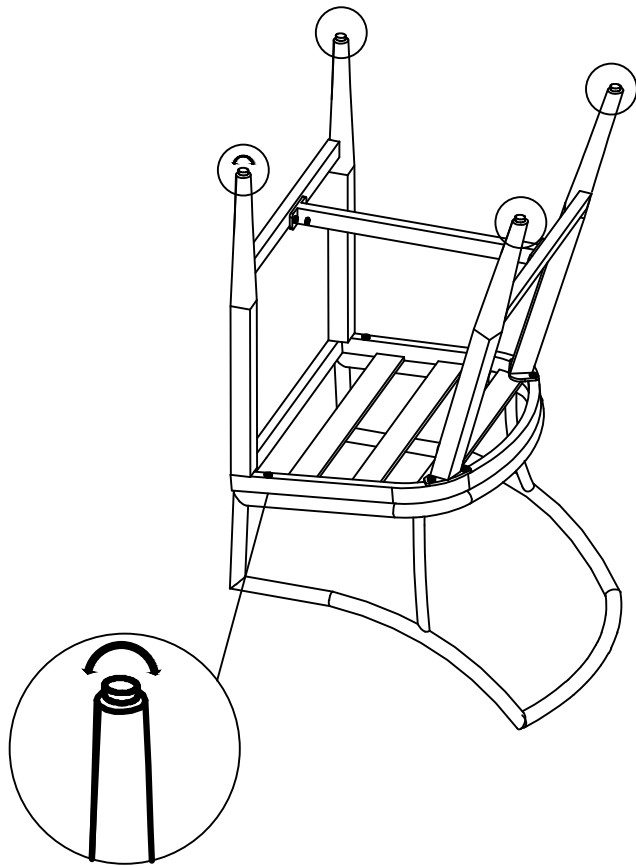

4

Adjustable feet pads.