

ASSEMBLY INSTRUCTIONS

EEI-7039

V0.16.04.24

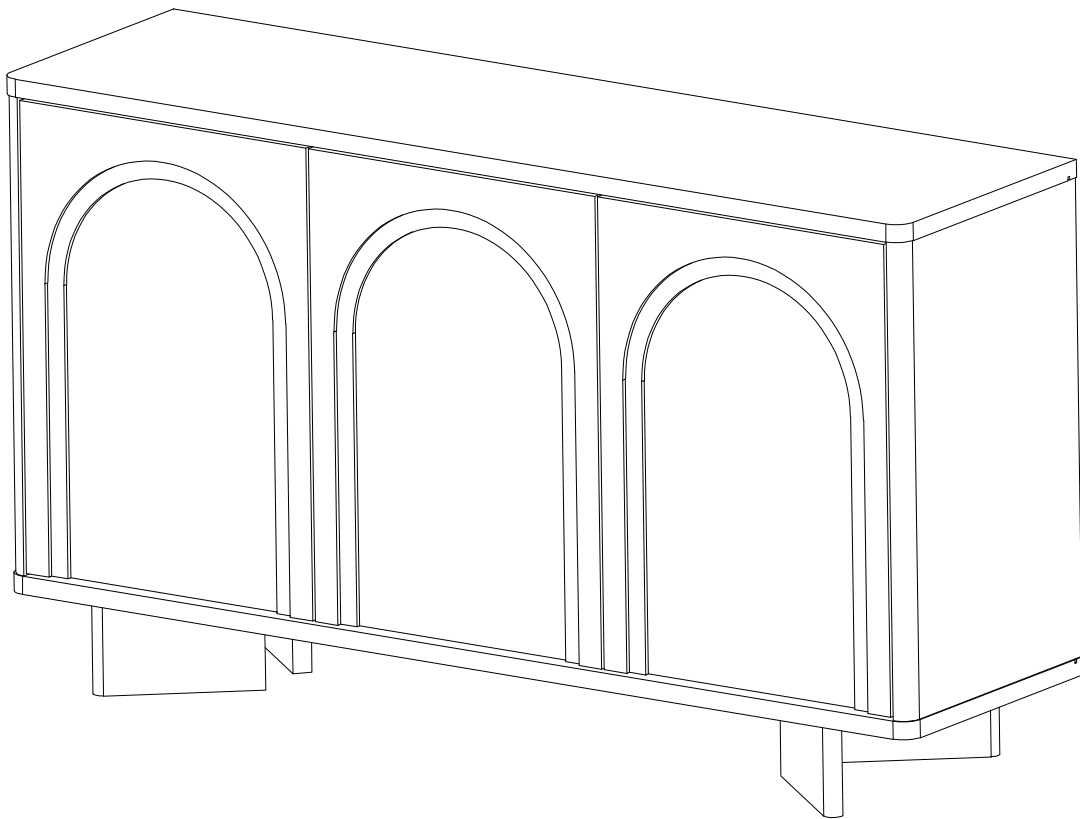

Questions? Contact us!

609.256.9000 • cs@modway.com
www.modway.com

***modway**

Let's get started!

*modway



Read through all of the instructions before starting



Care instructions are listed in the last step of this manual



Approx. 60 minutes assembly time



Make sure you have all parts and components before discarding any packing materials



2 people recommended for assembly

Only use hand tools to assemble this item. Do not use power tools.

Do not tighten bolts or screws completely until all hardware is lined up and inserted into the holes.

Do not over-tighten screws and bolts to avoid stripping the hardware or cracking the item.

Assemble your item on a flat, carpeted area, with plenty of space to work. This will prevent damage and scratches to your floors or the item while you're assembling the product.

Keep all components and packaging out of reach of children or animals to avoid risk of choking or suffocation.

Furniture components:

1	Side Panel Left	x1
2	Side Panel Right	x1
3	Top Panel	x1
4	Bottom Panel	x1
5	Divider Panel Left	x1
6	Divider Panel Right	x1
7	Adjustable Shelf Left / Right	x2
8	Adjustable Shelf Center	x1
9	Support Panel Leg	x2
10	Support Panel Leg	x2
11	Door Panel Left	x1
12	Door Panel Right / Center	x2
13	Back Panel Left / Right	x2
14	Back Panel Center	x1

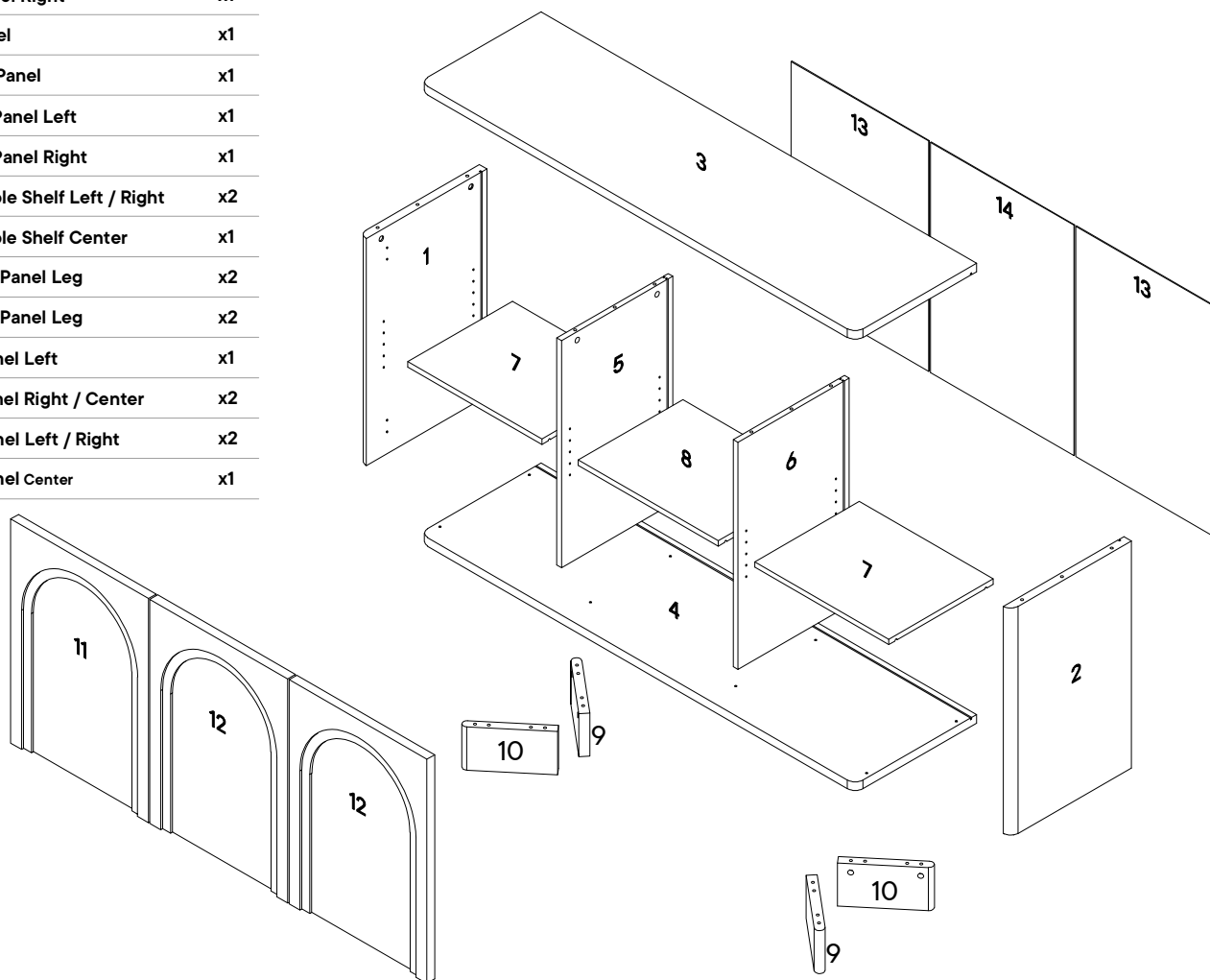



Wait!

Missing parts or hardware? Need assistance?

Contact us before returning your item. We're here to help!

609.256.9000 • cs@modway.com

Provided hardware:

A.		Screw M3.5 x 15 mm	x24
B.		Screw M6 x 13 mm	x12
C.		Screw M6 x 40 mm	x8
D.		Wood Dowel Ø8 x 25 mm	x4
E.		Wood Dowel Ø8 x 35 mm	x8
F.		Cam Bolt 20 x 5 mm	x16
G.		Cam Lock 15/15	x16
H.		Sft Cls Hinges 2/8" (Thin Cup)	x2
J.		Sft Cls Hinges 5/8" (Thin Cup)	x4
K.		Push Tool	x3
L.		Plastic Leg Stud	x8
M.		Shelf Pin	x12
N.		Allen Key	x1
P.		Wedge	x12
		Tipping Restraint Kit	x2

What you need:



You may also need:

+ Level
+ Hammer

Wait!

Missing parts or hardware? Need assistance?
Contact us before returning your item. We're here to help!
609.256.9000 • cs@modway.com

Step 1

HARDWARE

- E** Wood Dowel Ø8 x 35 mm x8
- F** Cam Bolt 20 x 5 mm x8

COMPONENTS

- 4** Bottom Panel x1
- 9** Support Panel Leg x2
- 10** Support Panel Leg x2

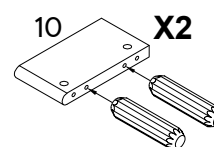
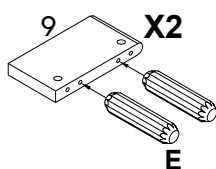
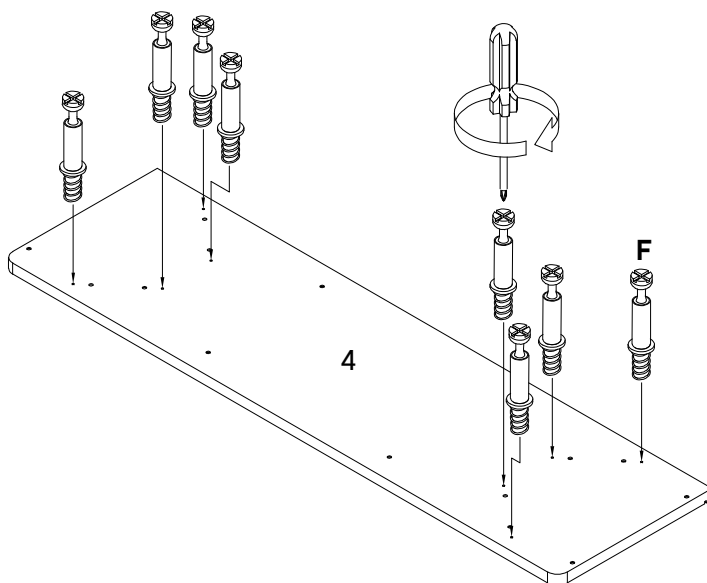

Step 2

HARDWARE

- G** Cam Lock 15/15 x8
- L** Plastic Leg Stud x8

COMPONENTS

- 4** Bottom Panel x1
- 9** Support Panel Leg x2
- 10** Support Panel Leg x2

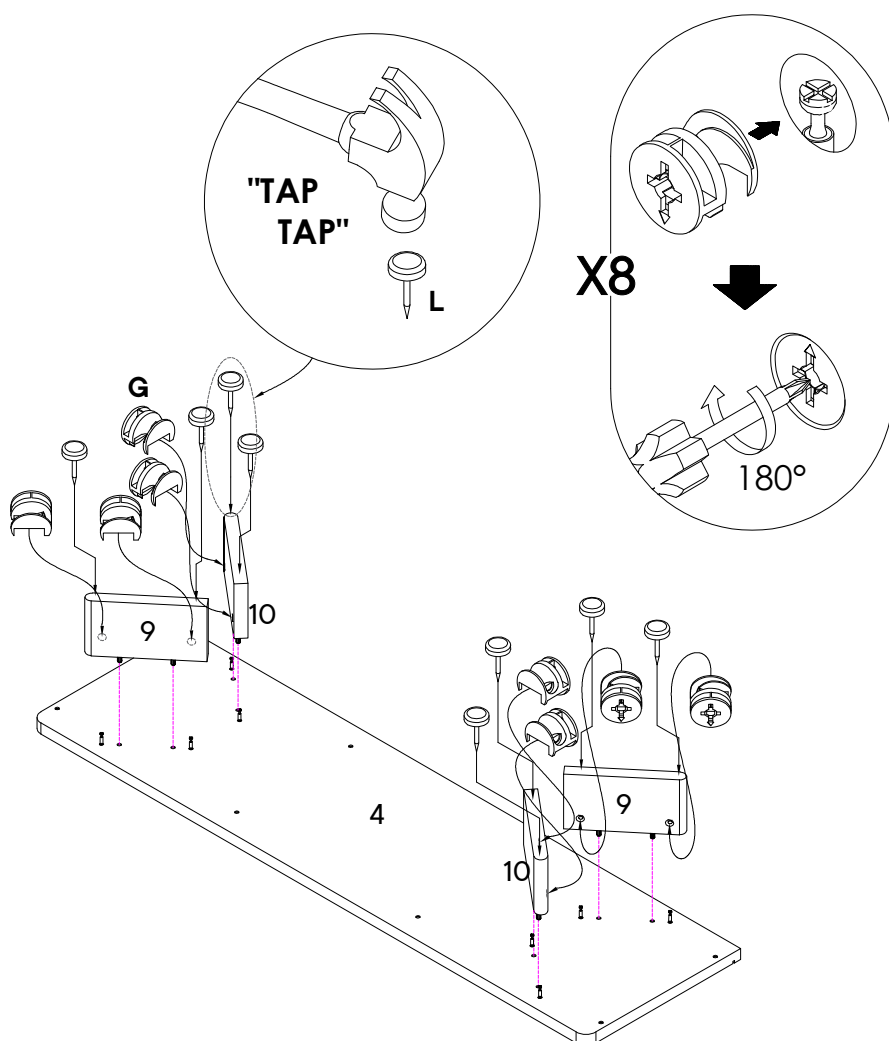

Step 3

HARDWARE

D Wood Dowel Ø8 x 25 mm x4

COMPONENTS

1 Side Panel Left x1

2 Side Panel Right x1

5 Divider Panel Left x1

6 Divider Panel Right x1

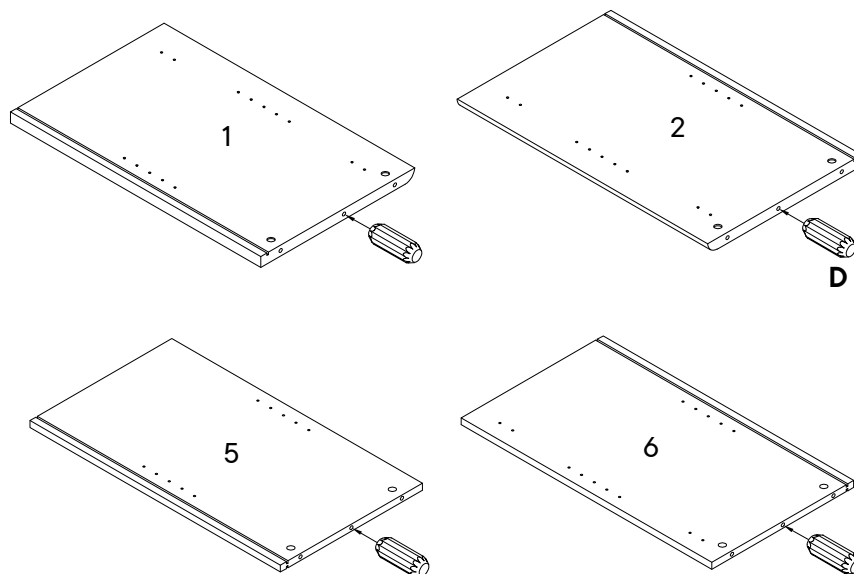

Step 4

HARDWARE

C Screw M6 x 40 mm x8

N Allen Key x1

COMPONENTS

1 Side Panel Left x1

2 Side Panel Right x1

4 Bottom Panel x1

5 Divider Panel Left x1

6 Divider Panel Right x1

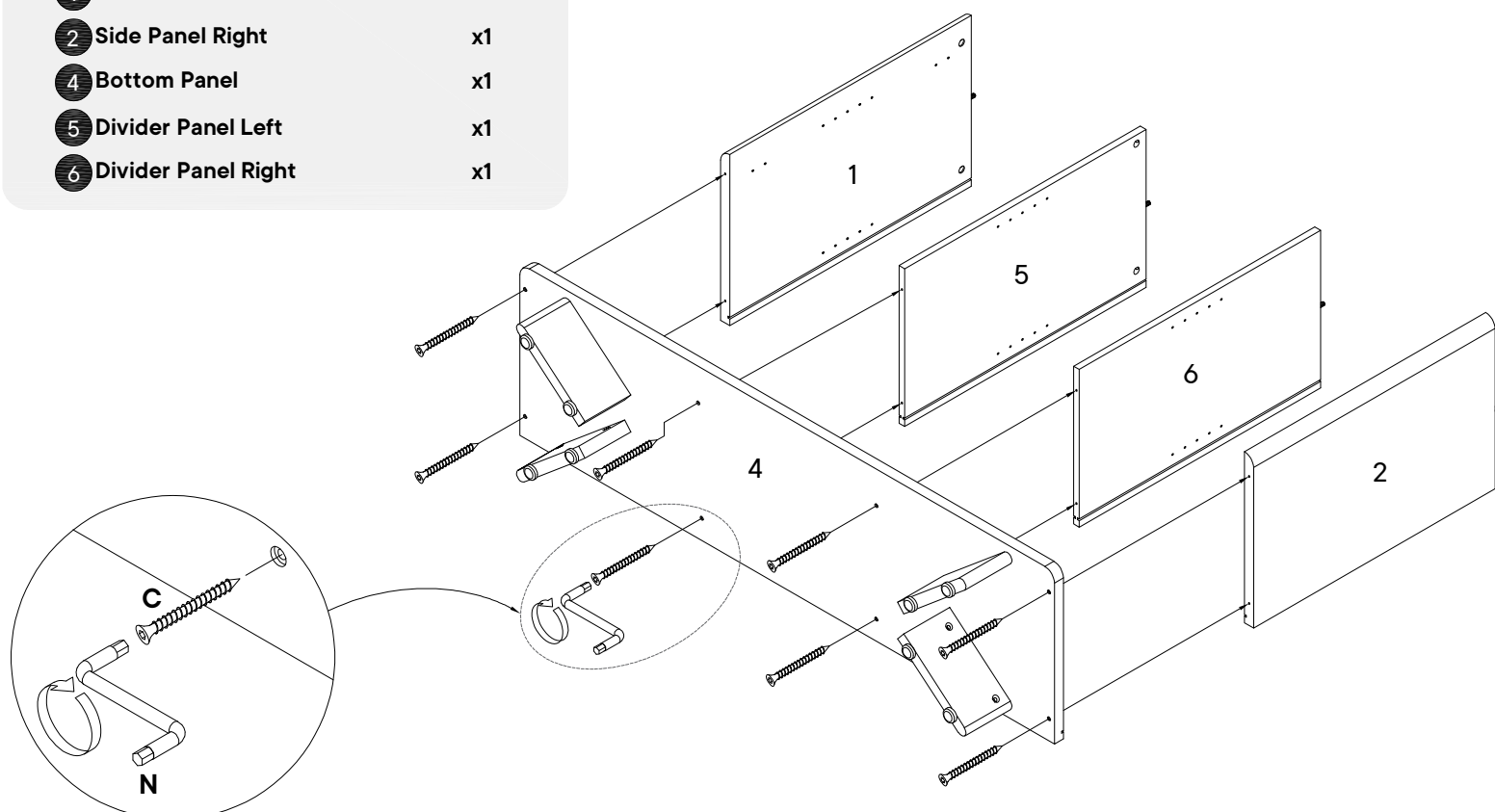

Step 5

COMPONENTS

- 13** Back Panel Left / Right x2
- 14** Back Panel Center x1

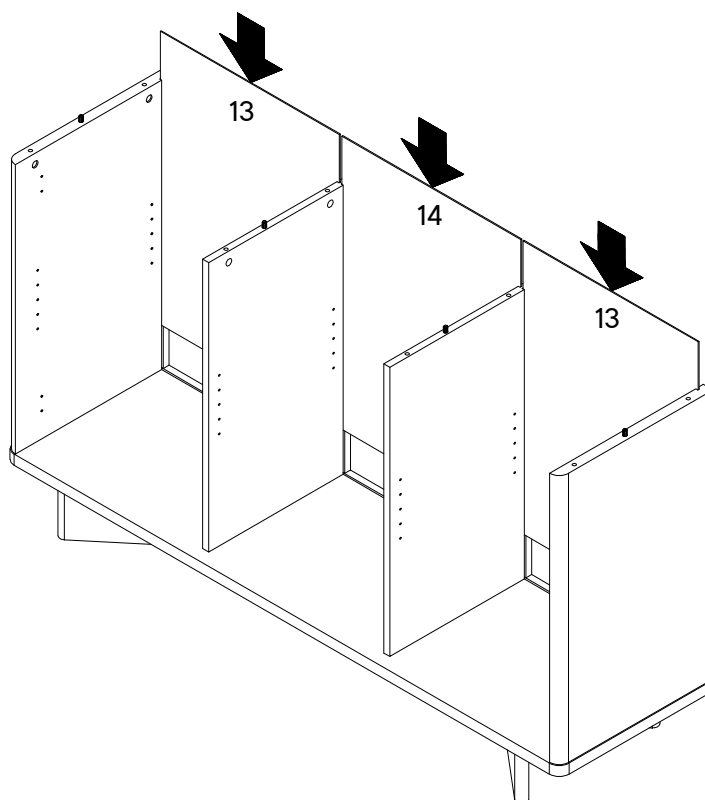

Step 6

HARDWARE

- F** Cam Bolt 20 x 5 mm x8
- K** Push Tool x3

COMPONENTS

- 3** Top Panel x1

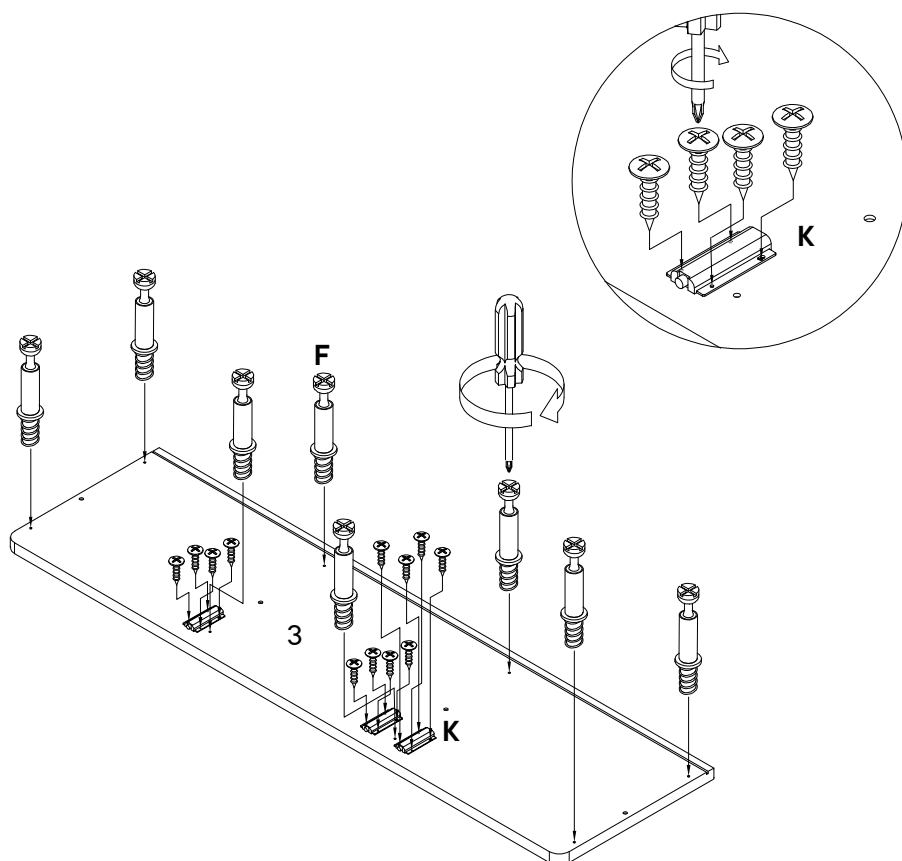

Step 7

HARDWARE

G Cam Lock 15/15 x8

COMPONENTS

1 Side Panel Left x1

2 Side Panel Right x1

3 Top Panel x1

5 Divider Panel Left x1

6 Divider Panel Right x1

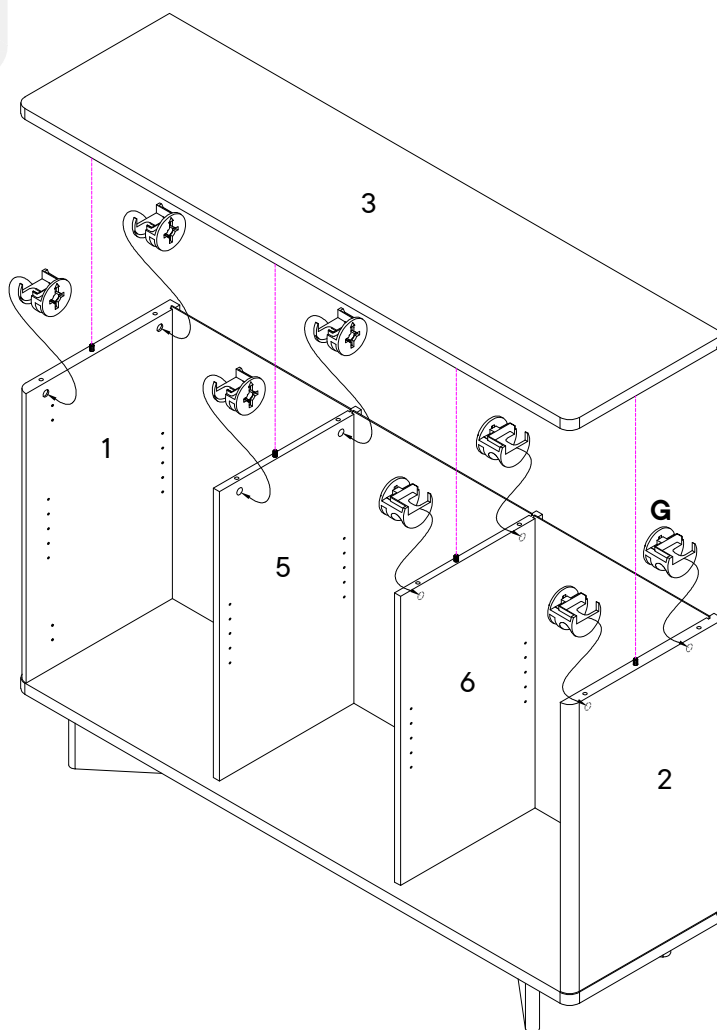
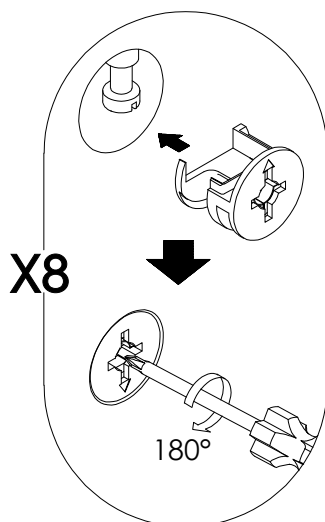

Step 8

HARDWARE

M Shelf Pin x12

COMPONENTS

7 Adjustable Shelf Left / Right x2

8 Adjustable Shelf Center x1

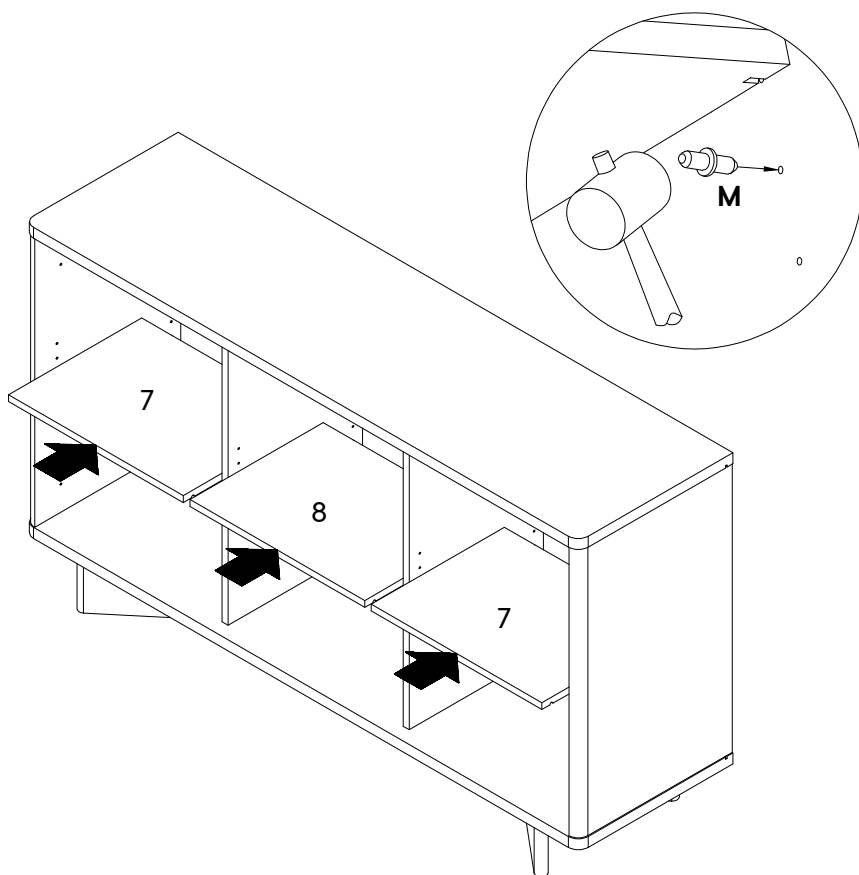

Step 9

HARDWARE

A Screw M3.5 x 15 mm x8

J Sft Cls Hinges 5/8" (Thin Cup) x4

K Push Tool x2

COMPONENTS

11 Door Panel Left x1

12 Door Panel Right / Center x1

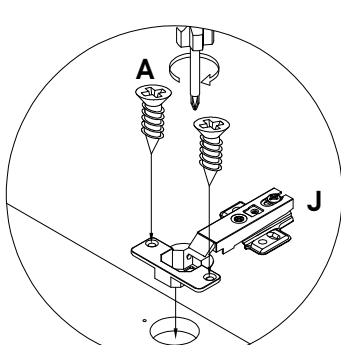
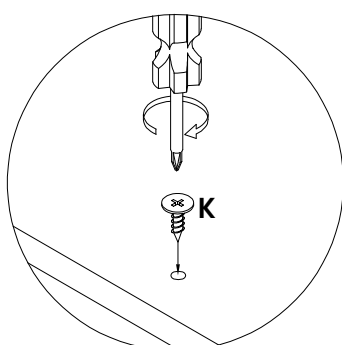
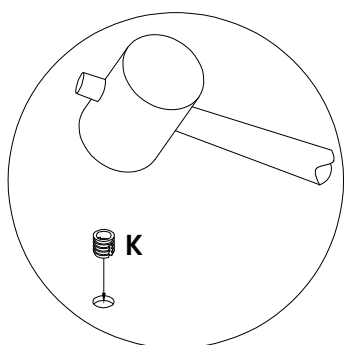
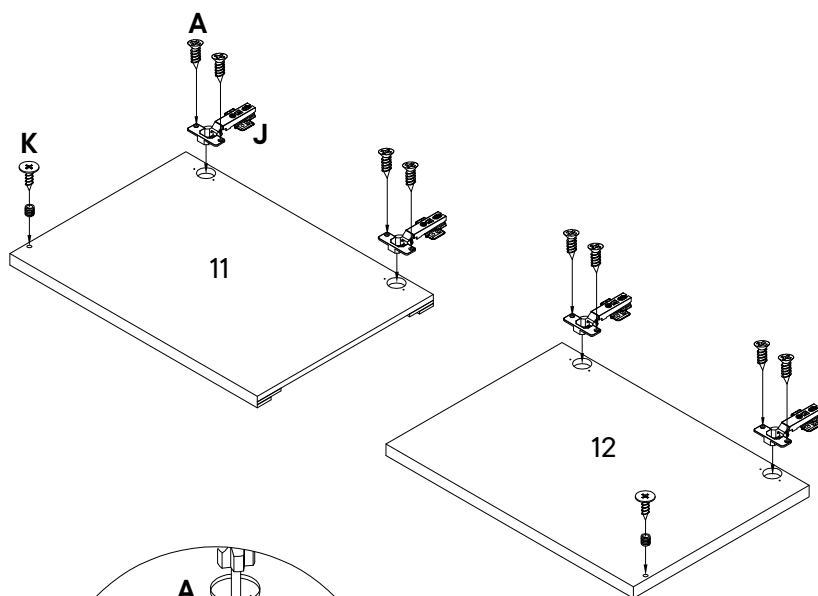

Step 10

HARDWARE

B Screw M6 x 13 mm x8

COMPONENTS

1 Side Panel Left x1

2 Side Panel Right x1

11 Door Panel Left x1

12 Door Panel Right / Center x1

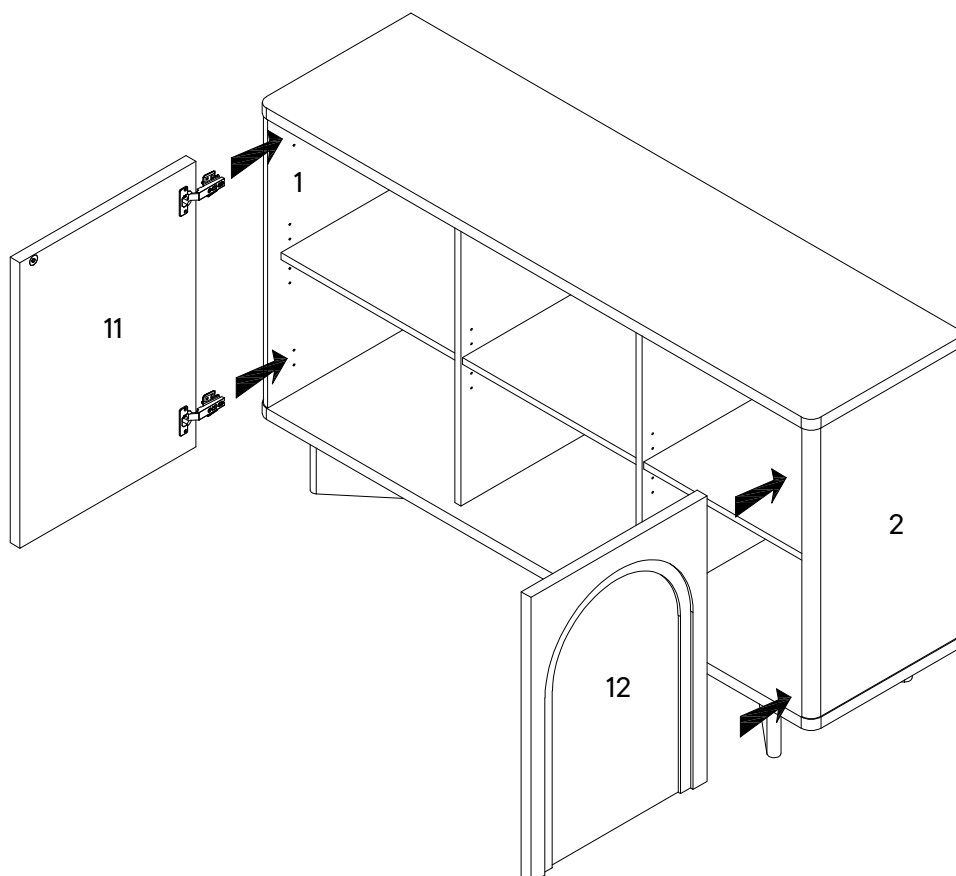
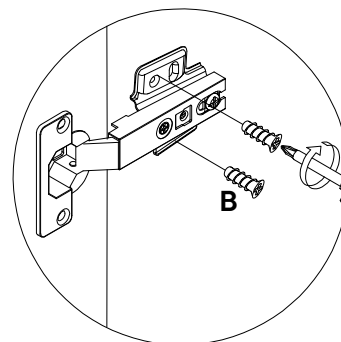

Left & Ride Door Alignment

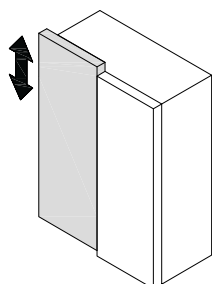
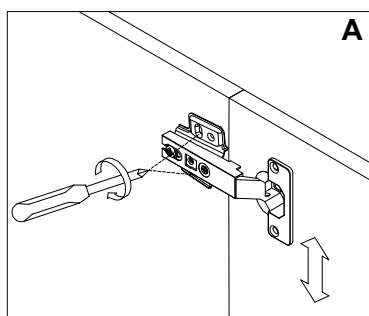
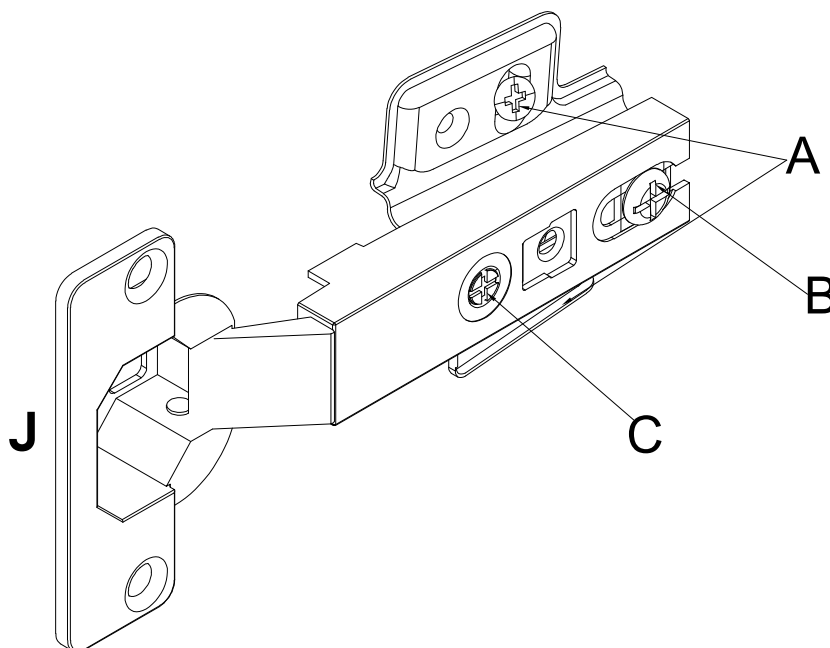

To Adjust the Vertical height.

Loosen the two screws "A" on both hinges. Two of them are usually in slotted holes which allows you to adjust up or down by few mm. Then tighten back up.

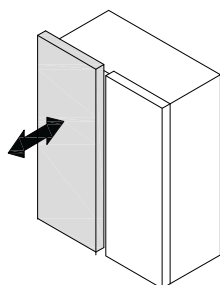
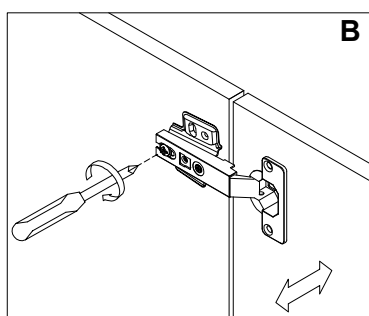

To Adjust depth.

Loosen Screw "B" and adjust door, if the door can not be adjusted, please loosen screw "C", then try again. Tighten screw "B" and "C".

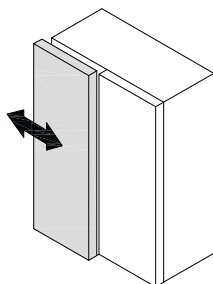
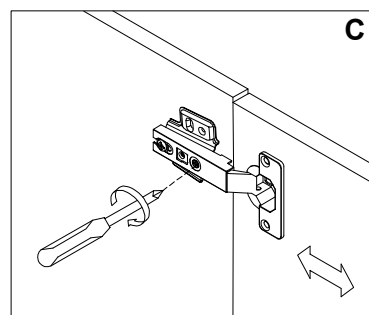

To Adjust side ways.

Turn screw "C" on BOTH hinges on each door.

Step 14

HARDWARE

- A** Screw M3.5 x 15 mm x4
- H** Sft Cls Hinges 2/8" (Thin Cup) x2
- K** Push Tool x1

COMPONENTS

- 12** Door Panel Right / Center x1

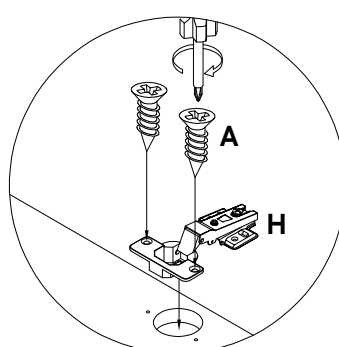
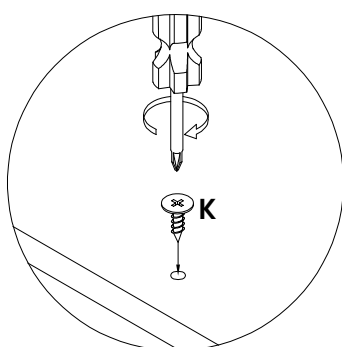
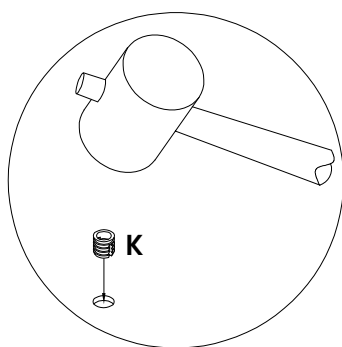
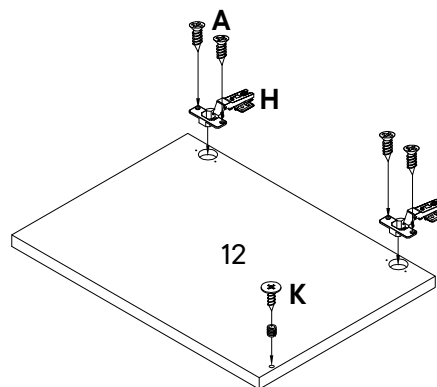

Step 15

HARDWARE

- B** Screw M6 x 13 mm x4

COMPONENTS

- 6** Divider Panel Right x1
- 12** Door Panel Right / Center x1

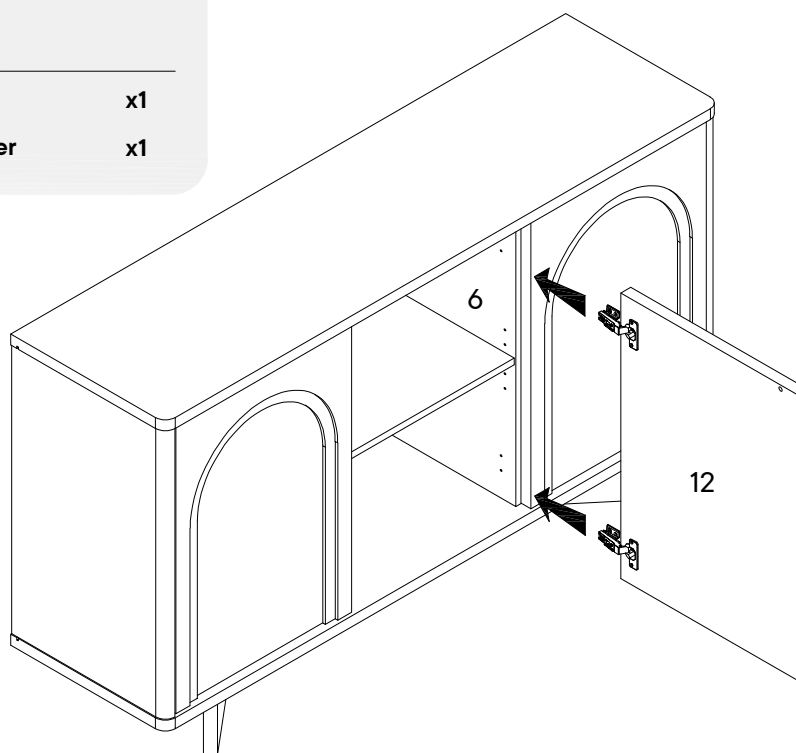
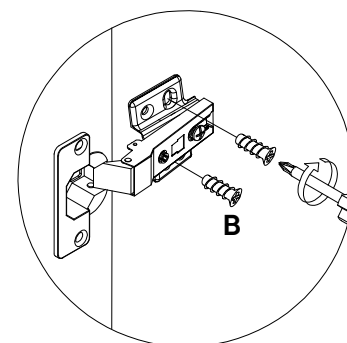

Middle Door Alignment

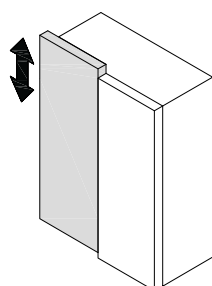
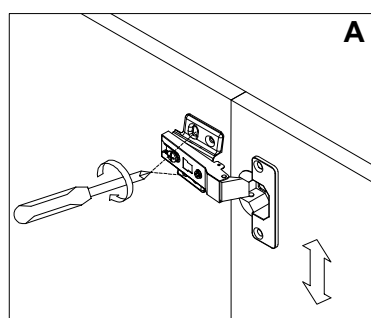
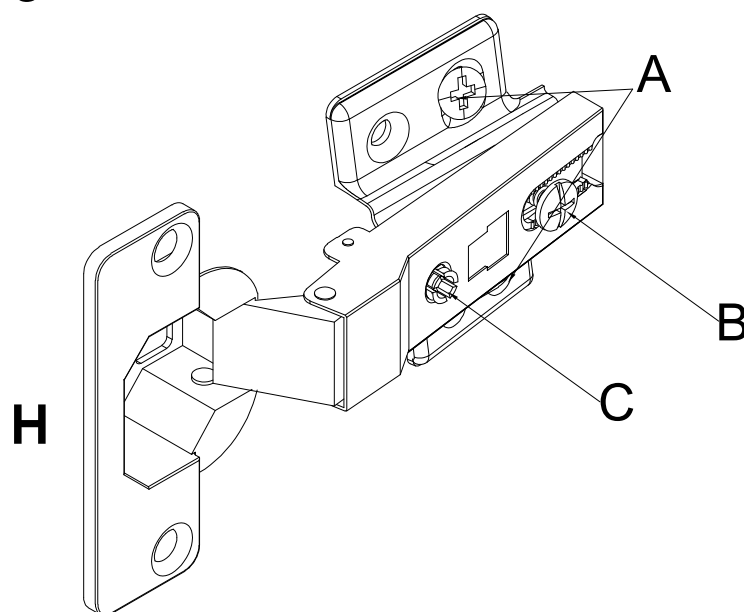

To Adjust the Vertical height.

Loosen the two screws "A" on both hinges. Two of them are usually in slotted holes which allows you to adjust up or down by few mm. Then tighten back up.

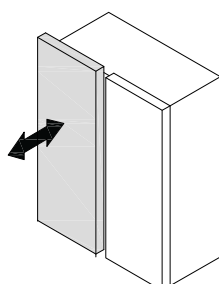
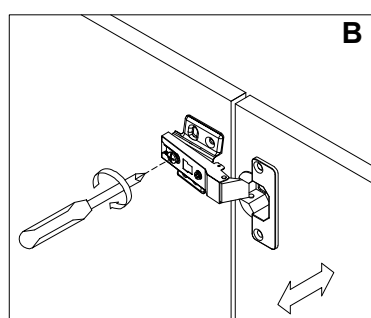

To Adjust depth.

Loosen Screw "B" and adjust door, if the door can not be adjusted, please loosen screw "C", then try again. Tighten screw "B" and "C".

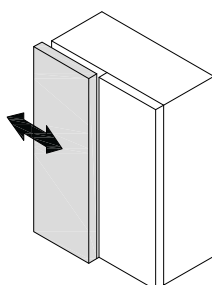
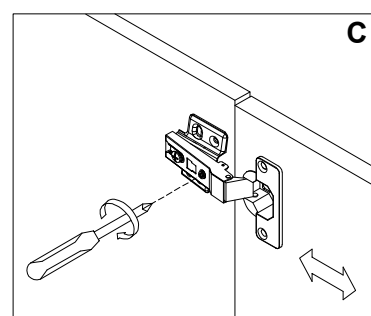

To Adjust side ways.

Turn screw "C" on BOTH hinges on each door.

Step 11

HARDWARE

- A** Screw M3.5 x 15 mm x12
- P** Wedge x12

COMPONENTS

- 13** Back Panel Left / Right x2
- 14** Back Panel Center x1

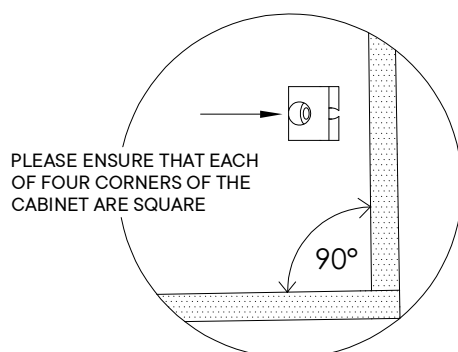
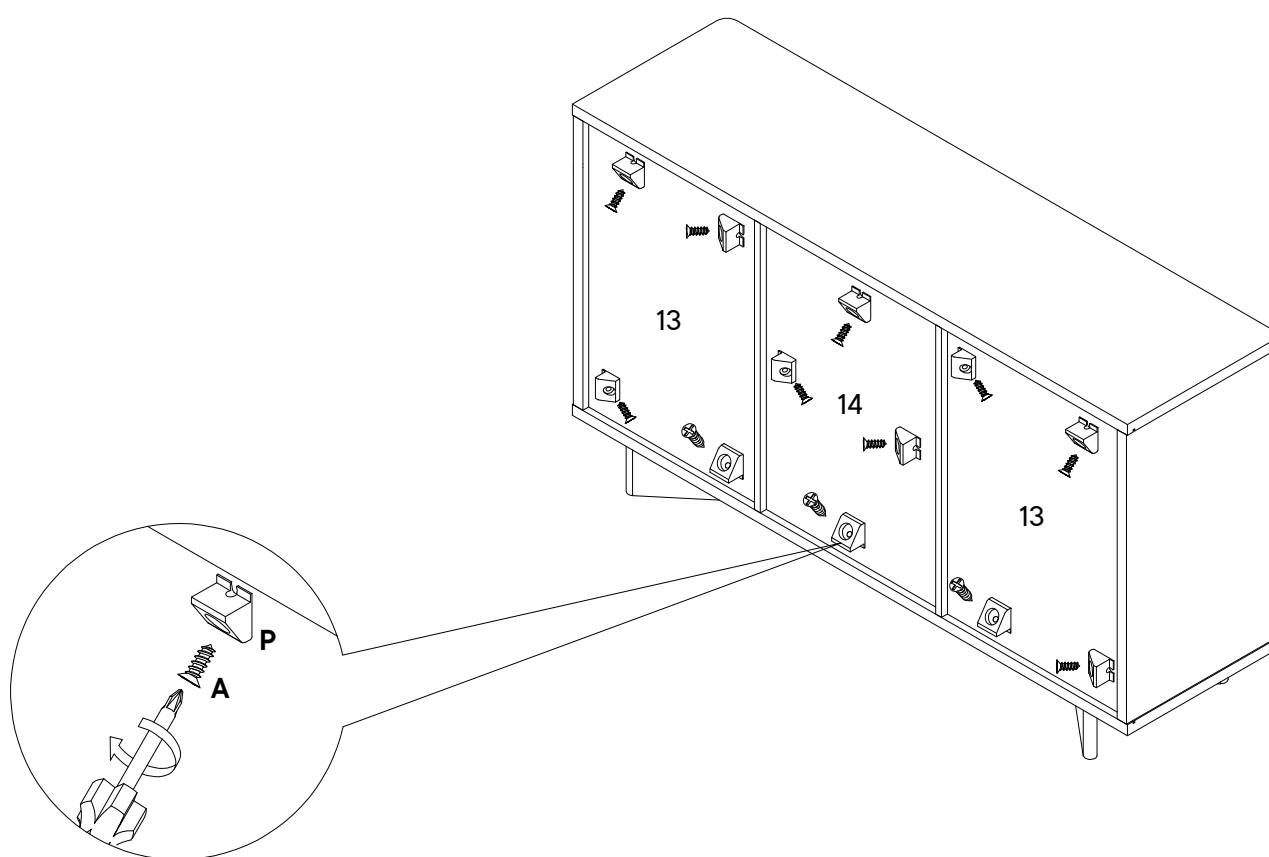

Great job!

Your New Sideboard is complete

♥ CARING FOR YOUR ITEM

Indoor use only

Not contract grade.

Clean using a non-abrasive cloth and a mild cleaner.

Never use harsh chemical, as they could damage the finish or integrity of the item.

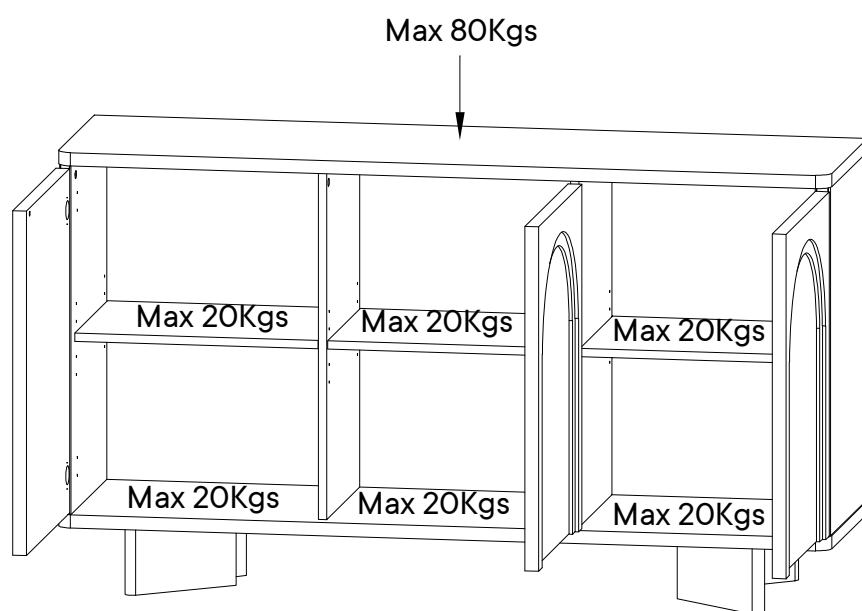

CONNECT WITH US!

Tag us [@modway_furniture](#) and [#modway](#) for a chance to be featured.

TIPPING RESTRAINTS KIT INSTALLATION GUIDANCE

This tipping restraint is not an earthquake restraint. If you wish to add the extra security of earthquake restraints, they must be purchased and installed separately.

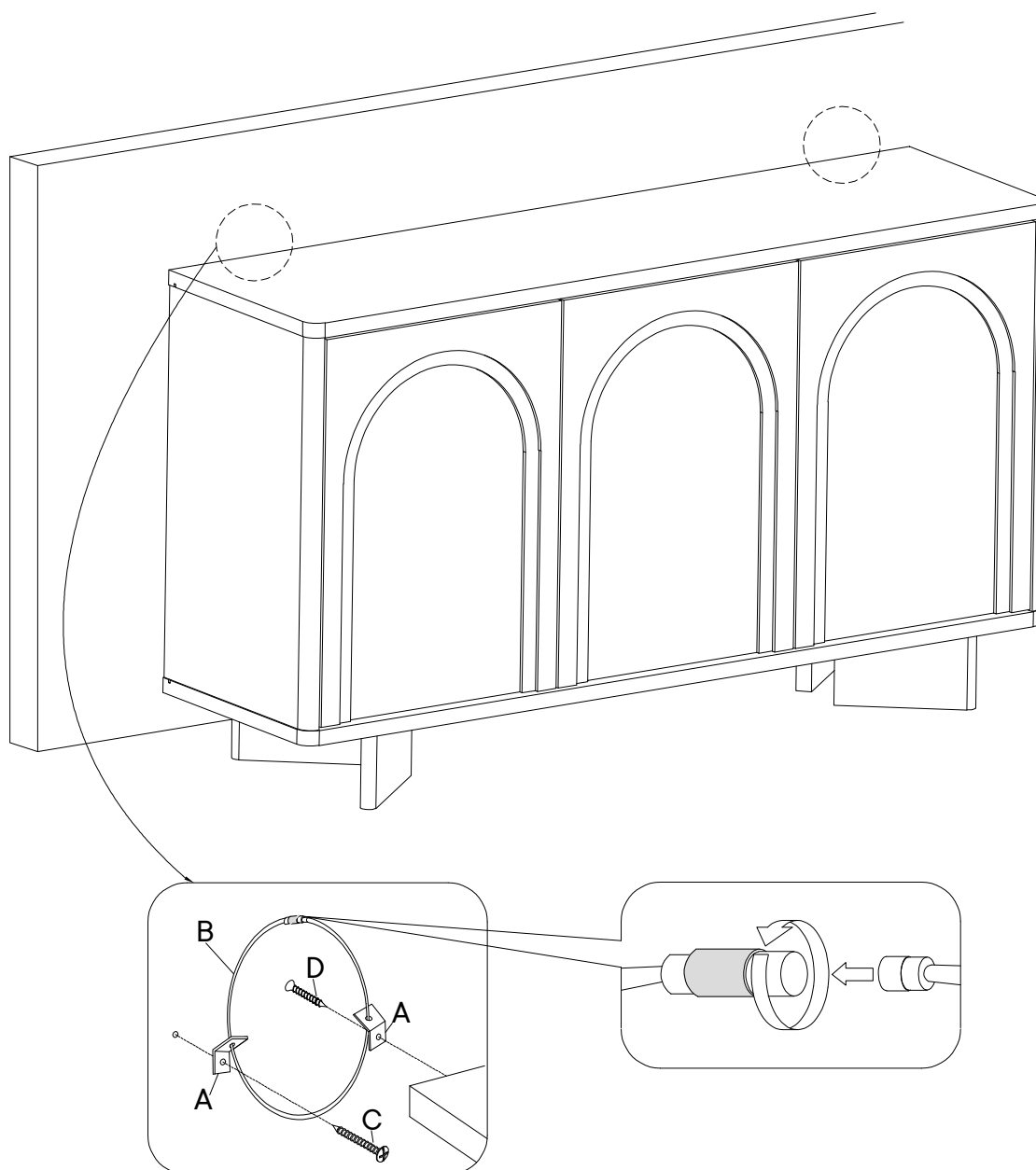
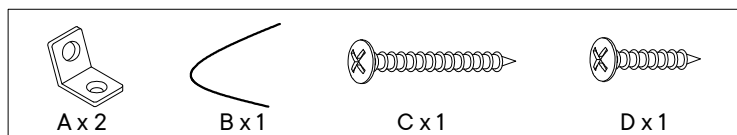

Installation Instructions :

1. Determine where the furniture is to be placed and find the center line of a wooden stud using a stud finder.
2. Drill a 1/8" pilot hole on the wooden stud approximately 3" below the height of unit top.
3. Attach one bracket (A) securely with screw (C) into the pilot hole on the wall.
4. Position the furniture in place and attach the other bracket (A) with screw (D) to the back edge of unit top in line with the bracket (A) on the wall.
5. Put the male end of the steel cable (B) through each bracket. Securely connect both ends together by turning the female connector clockwise.