

ASSEMBLY INSTRUCTIONS

LAYTON UPHOLSTERED BED

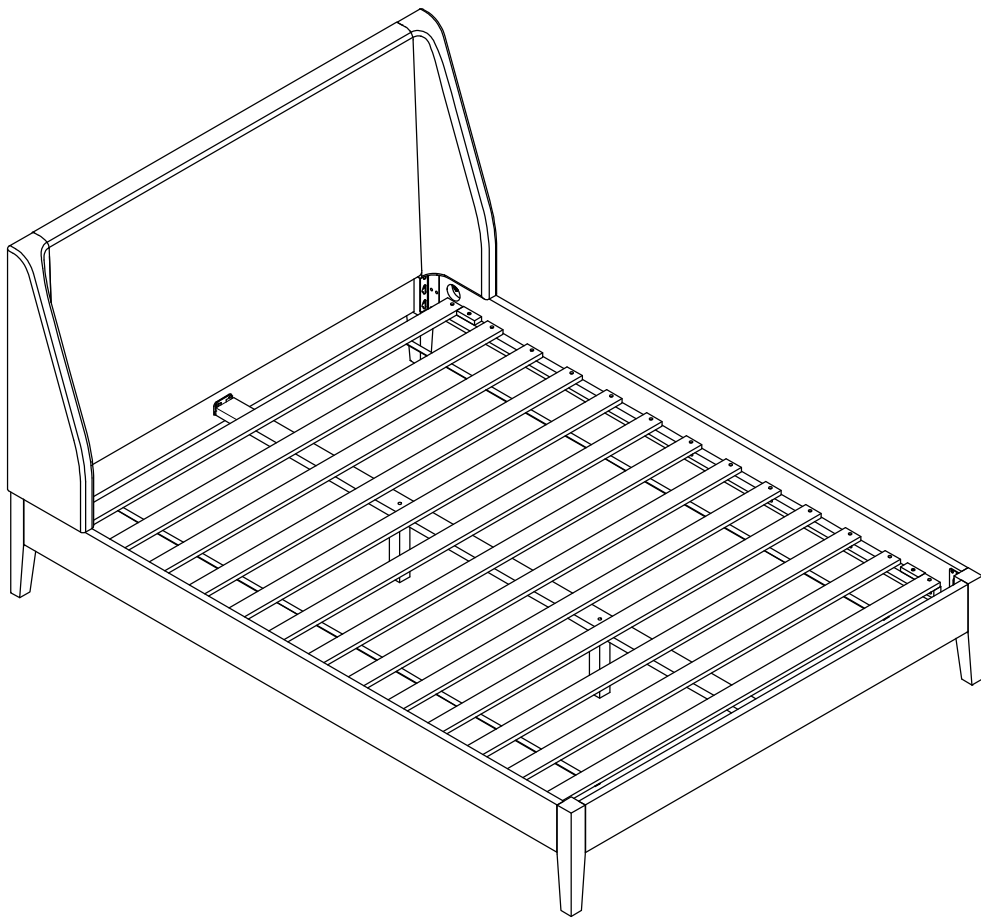

ASSEMBLY INSTRUCTIONS

Please kindly read these instructions carefully and keep for future reference. Refer to parts inventory for guidance, and ensure you have all pieces before starting.

When assembling, place all parts on a soft, clean, and flat surface such as a carpet to prevent scratches.

If you're having difficulty, our friendly Customer Care team is always here to help. **Call us at (310)-873-3380** during business hours, email support@adriaworkshop.com or chat live at www.adriaworkshop.com

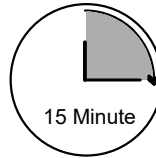



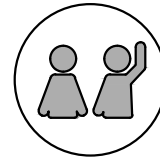

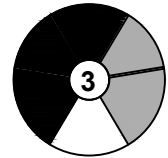

TIME



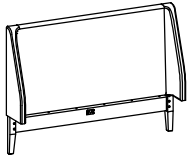





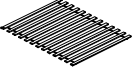

OF PEOPLE

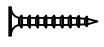

DIFFICULTY

CODE	PART LIST	Q'TY
①	HEADBOARD 	1 PC
②	LEFT SIDE 	1 PC
③	RIGHT SIDE 	1 PC
④	FOOTBOARD 	1 PC
⑤	CENTER SUPPORT 	1 PC
⑥	CENTER LEG 	2 PCS
⑦	SLATS 	1 PC

CODE	HARDWARE LIST	Q'TY
Ⓐ	BOLT M8x30 	12 PCS
Ⓑ	SPRING WASHER 8.5 	14 PCS
Ⓒ	FLAT WASHER 8.5 	14 PCS
Ⓓ	HANGER BOLTS M8x70mm = 2PCS 	2 PCS
Ⓔ	SCREW M4x25 	26 PCS
Ⓕ	ALLEN KEY 	1 PC
Ⓖ	HEX NUT M8 	2 PCS
Ⓗ	OPEN WRENCH 	1 PC
SCREW DRIVER (NOT INCLUDED) 		

Note: Make sure you have all the parts and hardware with quantity listed above before assembling the product. A screwdriver is also required (not included)

STEP 1

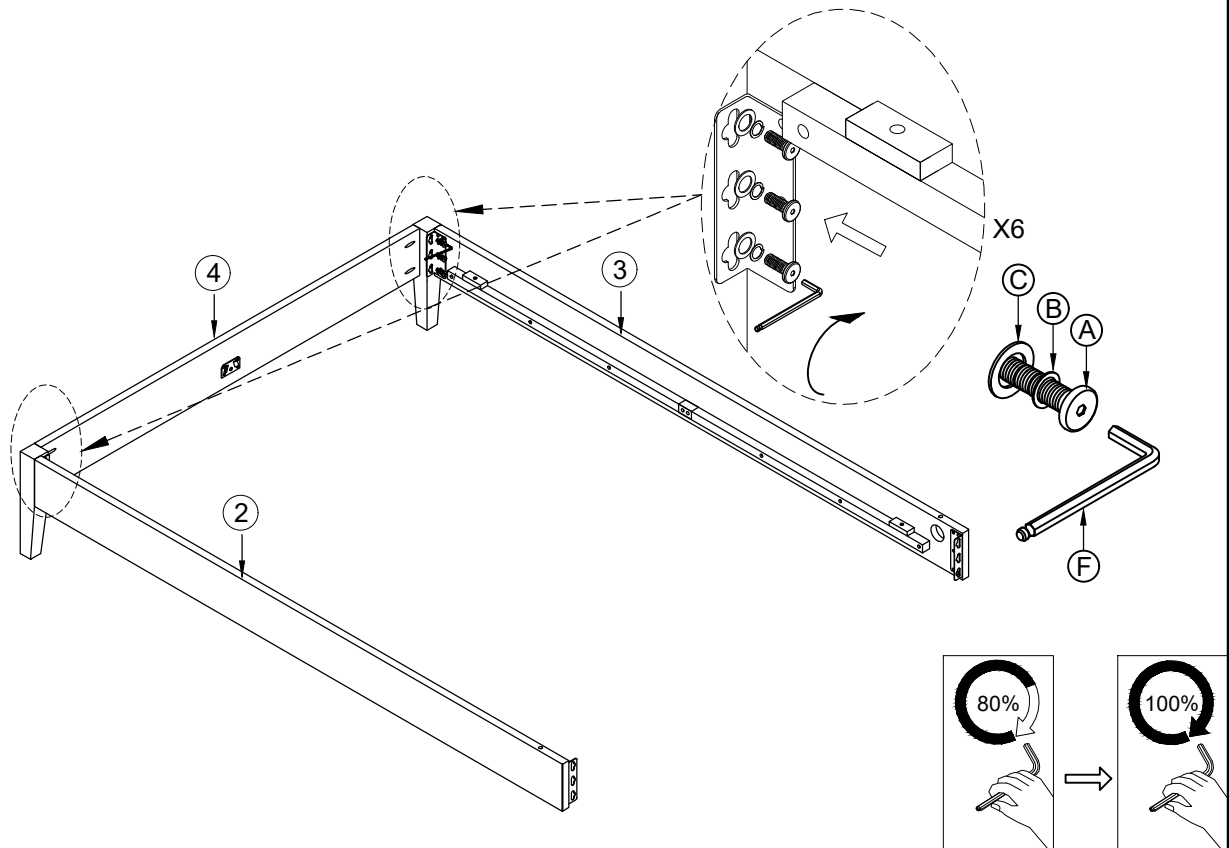

NOTE: FIRST, TIGHTEN ALL BOLTS TO 80% THEN TIGHTEN ALL BOLTS TO 100%
-PLEASE FOLLOW THE STEPS ABOVE TO AVOID THE ASSEMBLY DIFFICULTY.

STEP 2

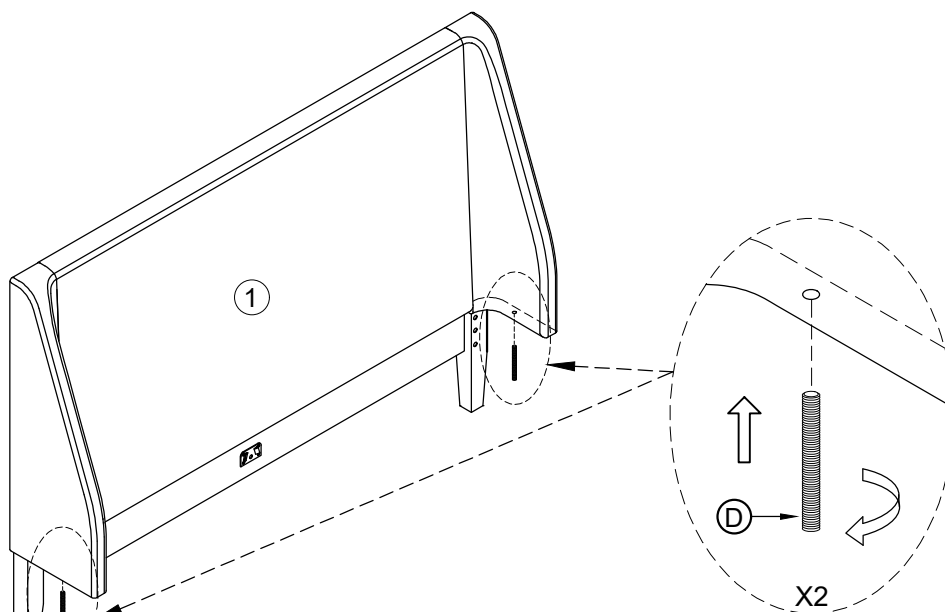

Turn bolt (D), to the HB (1)
first the protruding part out from 40-45mm

STEP 3

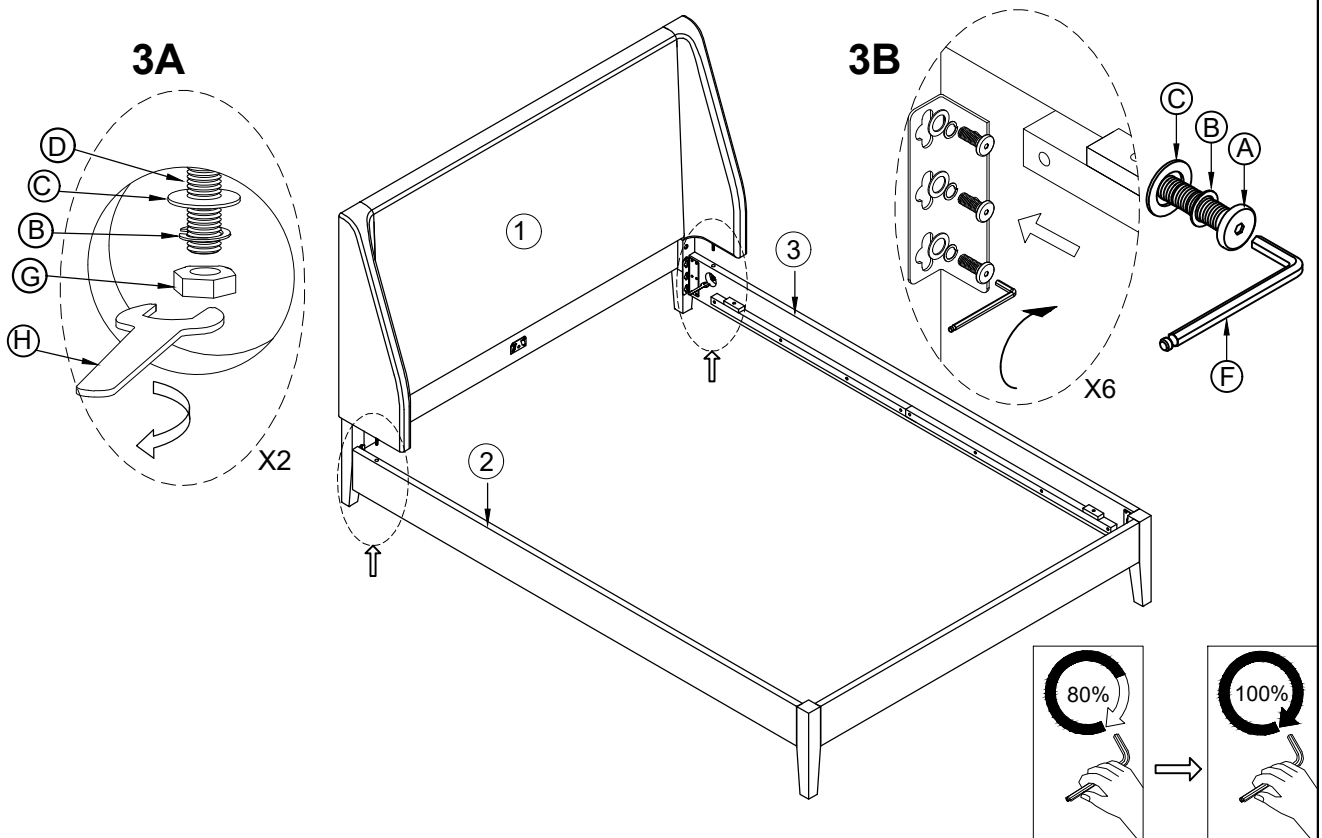

NOTE: FIRST, TIGHTEN ALL BOLTS TO 80% THEN TIGHTEN ALL BOLTS TO 100%
-PLEASE FOLLOW THE STEPS ABOVE TO AVOID THE ASSEMBLY DIFFICULTY.

STEP 4

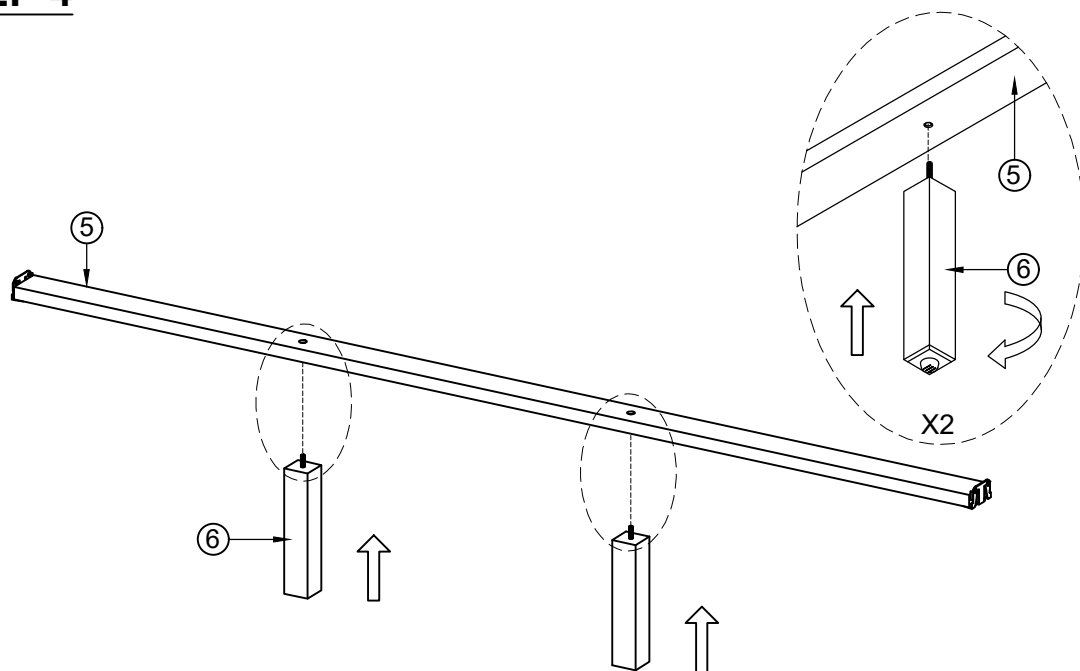

STEP 5

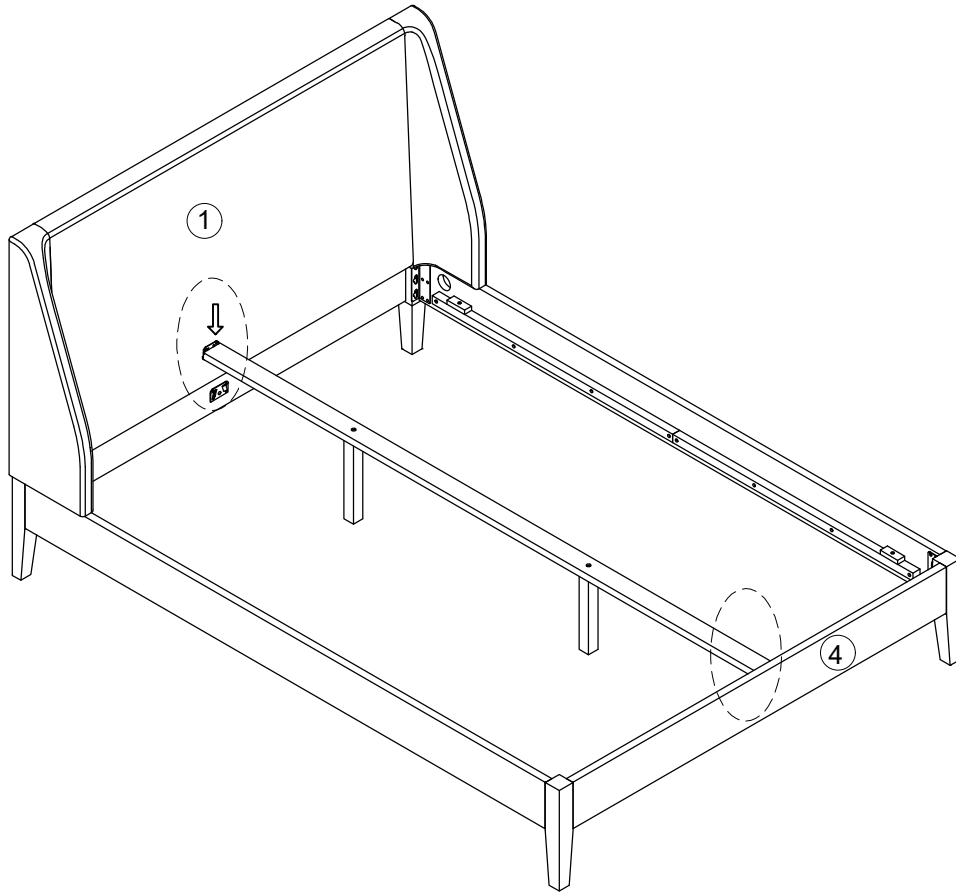

STEP 6 & FINISH

