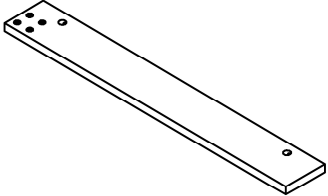
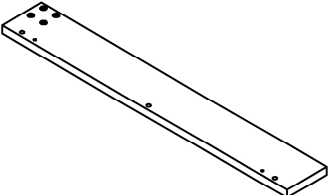
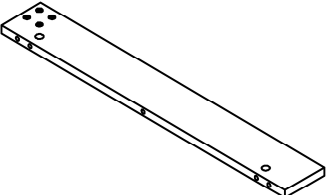
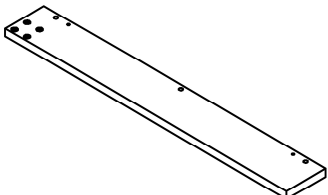
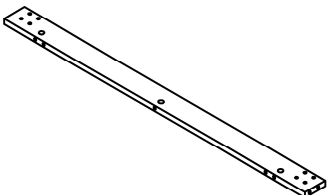

**TABLE A MANGER -  
32"X 48" / FAUX BOIS TAUPE**

**DINING TABLE -  
32"X 48" / TAUPE RECLAIMED WOOD-LOOK**



**LISTE DES PIÈCES**  
**PARTS LIST**

PIÈCE / PART #	IMAGE	DESCRIPTION	QTY / QTÉ
1		<p style="text-align: center;">LEG PATTE</p>	2
2		<p style="text-align: center;">LEG PATTE</p>	2
3		<p style="text-align: center;">LEG PATTE</p>	2
4		<p style="text-align: center;">LEG PATTE</p>	2
5		<p style="text-align: center;">CROSSBAR BARRE TRANSVERSALE</p>	2

**LISTE DES PIÈCES**  
**PARTS LIST**

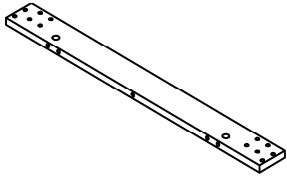
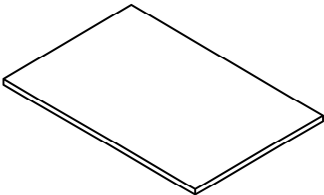
PIÈCE / PART #	IMAGE	DESCRIPTION	QTY / QTÉ
<b>6</b>		<b>CROSSBAR BARRE TRANSVERSALE</b>	<b>2</b>
<b>7</b>		<b>TABLE TOP SURFACE DE TABLE</b>	<b>1</b>

**LISTE DES PIÈCES DE MONTAGE**  
**HARDWARE LIST**

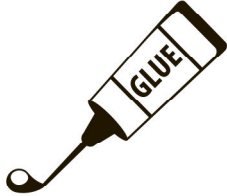
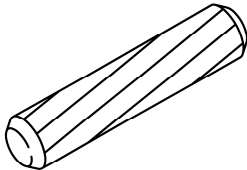
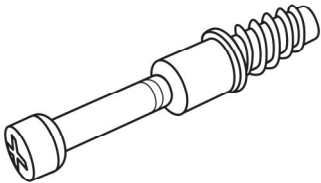
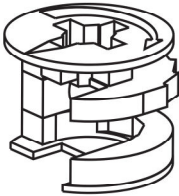
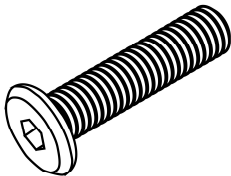
PIÈCE / PART #	IMAGE	DESCRIPTION	QTY / QTÉ
<b>A</b>		GLUE - 40G COLLE - 40G	<b>1</b>
<b>B</b>		WOOD DOWEL - Ø3/8" X 1 1/8" GOUJON DE BOIS - Ø3/8" X 1 1/8"	<b>30</b>
<b>C</b>		CAM LOCK SCREW - 1 3/8" VIS CAM LOCK - 1 3/8"	<b>18</b>
<b>D</b>		CAM LOCK CONNECTOR - Ø5/8" X 1/2" ÉCROU CAM LOCK - Ø5/8" X 1/2"	<b>18</b>
<b>E</b>		ASSEMBLING BOLT - 1 3/8" BOULON D'ASSEMBLAGE - 1 3/8"	<b>32</b>

**LISTE DES PIÈCES DE MONTAGE**  
**HARDWARE LIST**

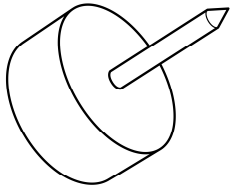
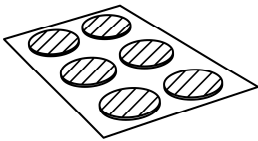
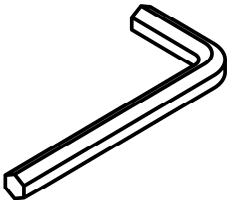
PIÈCE / PART #	IMAGE	DESCRIPTION	QTY / QTÉ
<b>F</b>		FLOOR PROTECTOR - 3/4" PROTECTEUR DE PLANCHER - 3/4"	<b>8</b>
<b>G</b>		FINISHING STICKER - 3/4" COLLANT DE FINITION - 3/4"	<b>18</b>
<b>H</b>		HEX KEY CLÉ HEXAGONALE	<b>1</b>

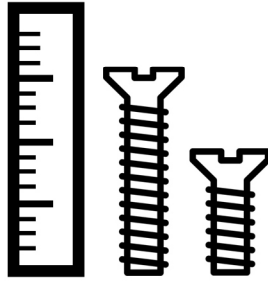

**OUTIL DE VÉRIFICATION DE DIMENSIONS DES PIÈCES  
HARDWARE DIMENSIONS VERIFICATION TOOL**

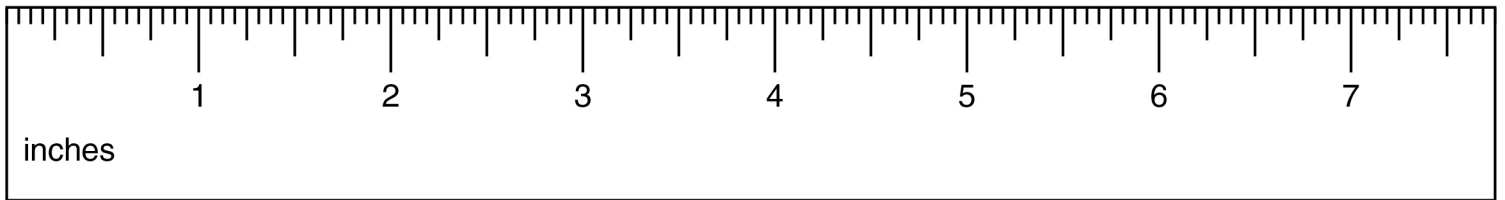

## ÉTAPE / STEP 1

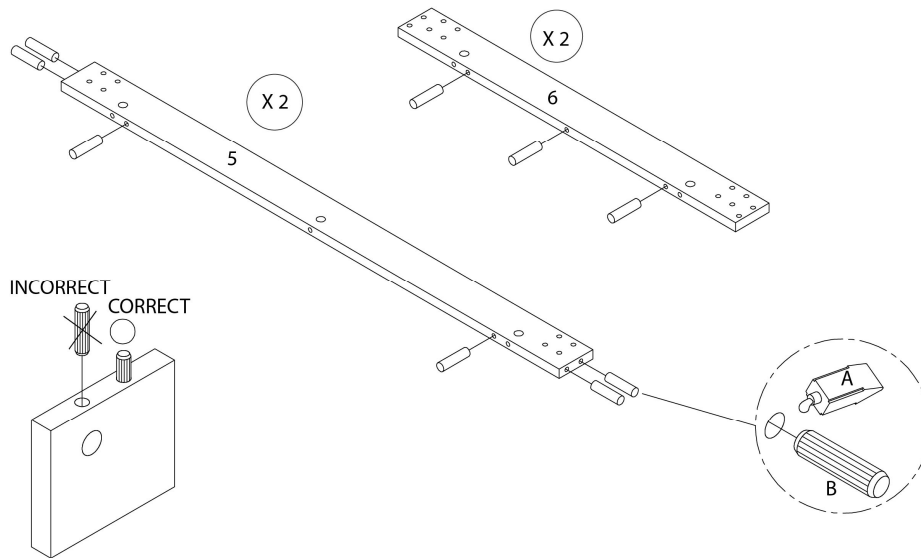
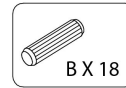

## ÉTAPE / STEP 2

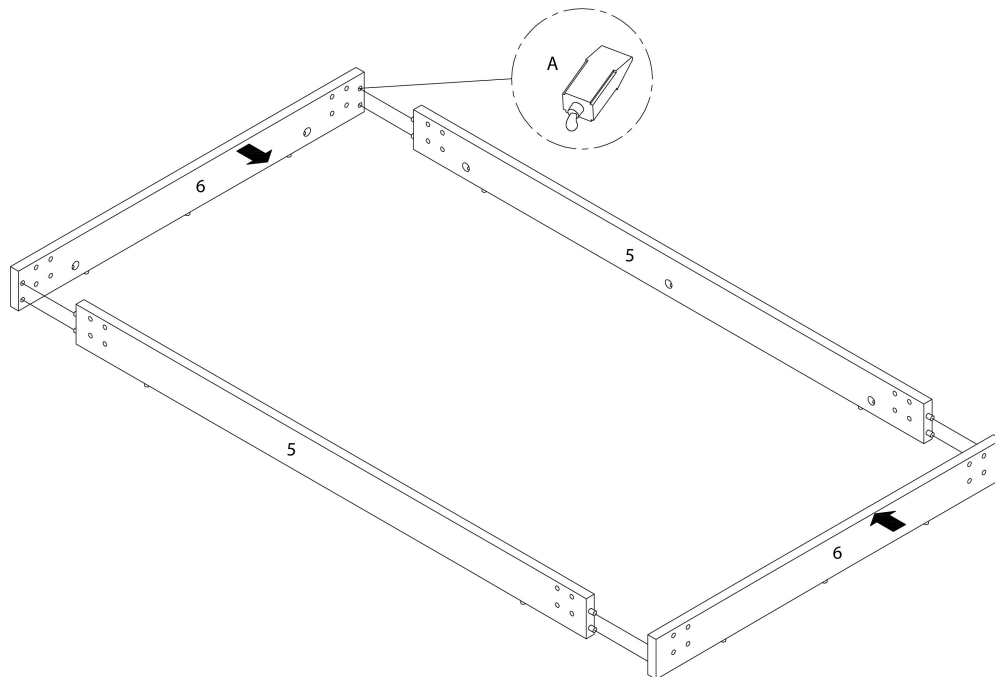

ÉTAPE / STEP 3

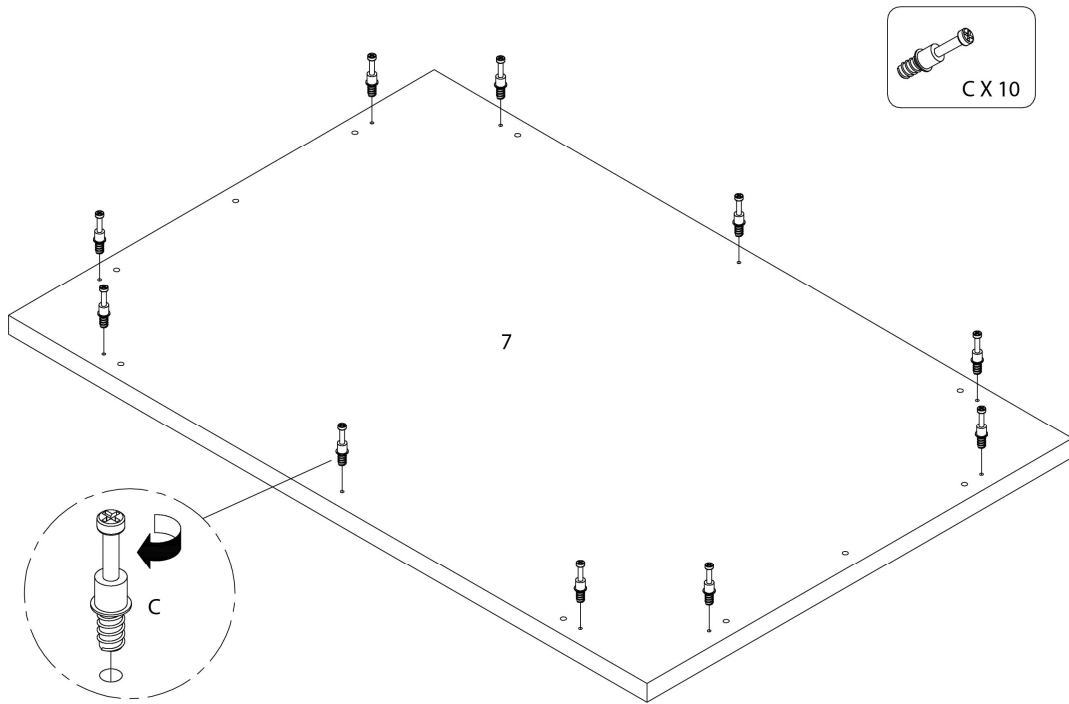

ÉTAPE / STEP 4

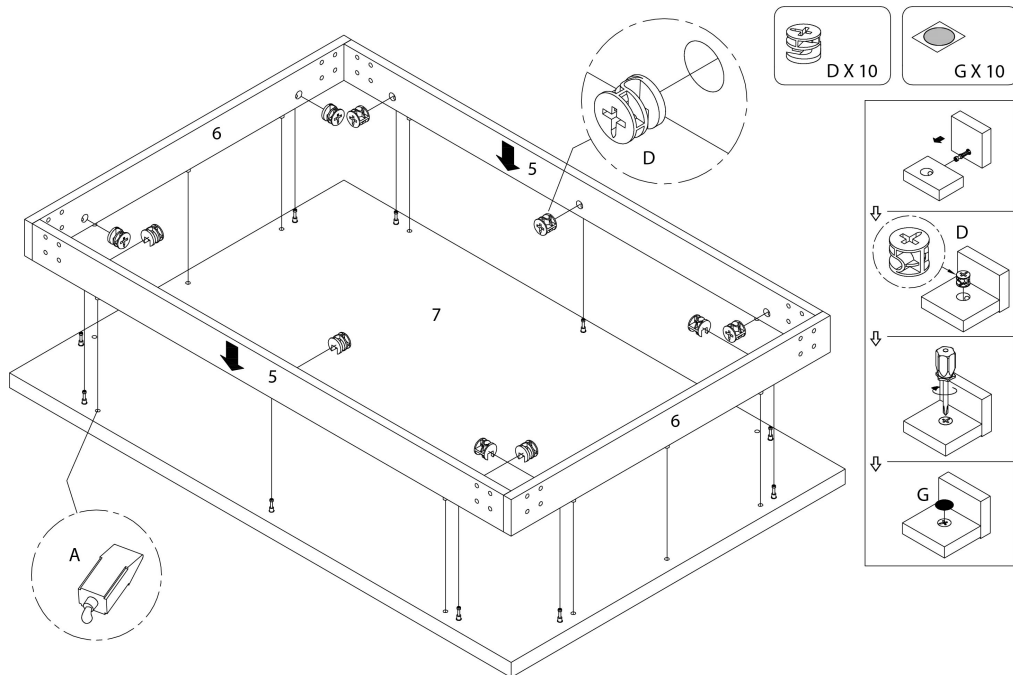

ÉTAPE / STEP 5

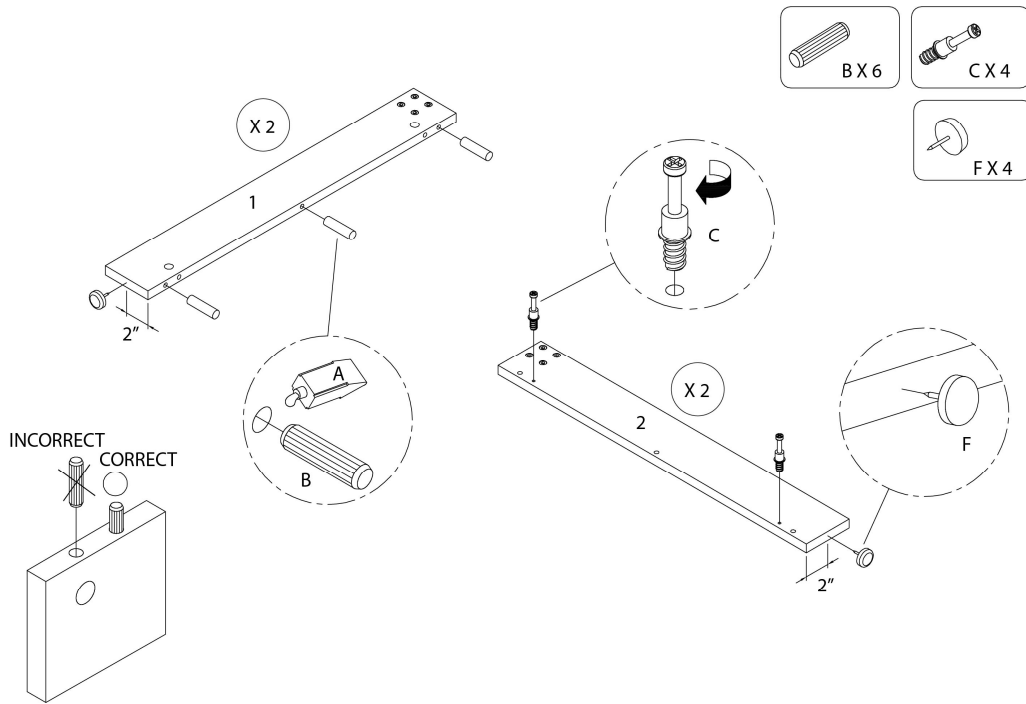

ÉTAPE / STEP 6

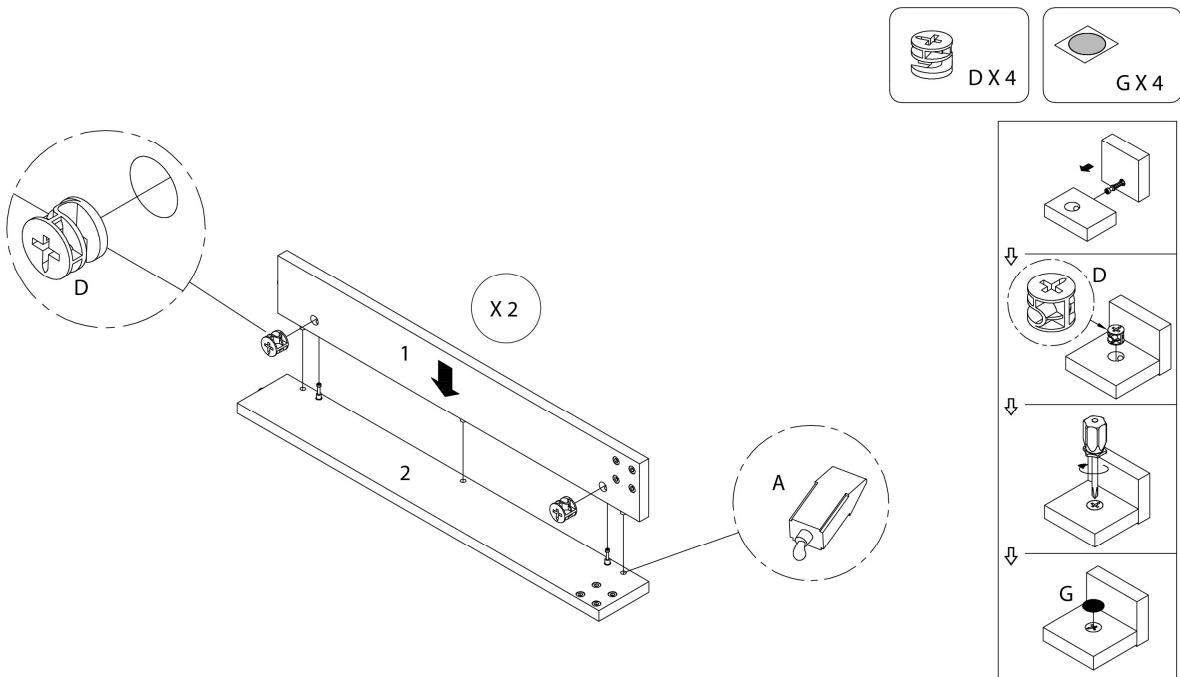

ÉTAPE / STEP 7

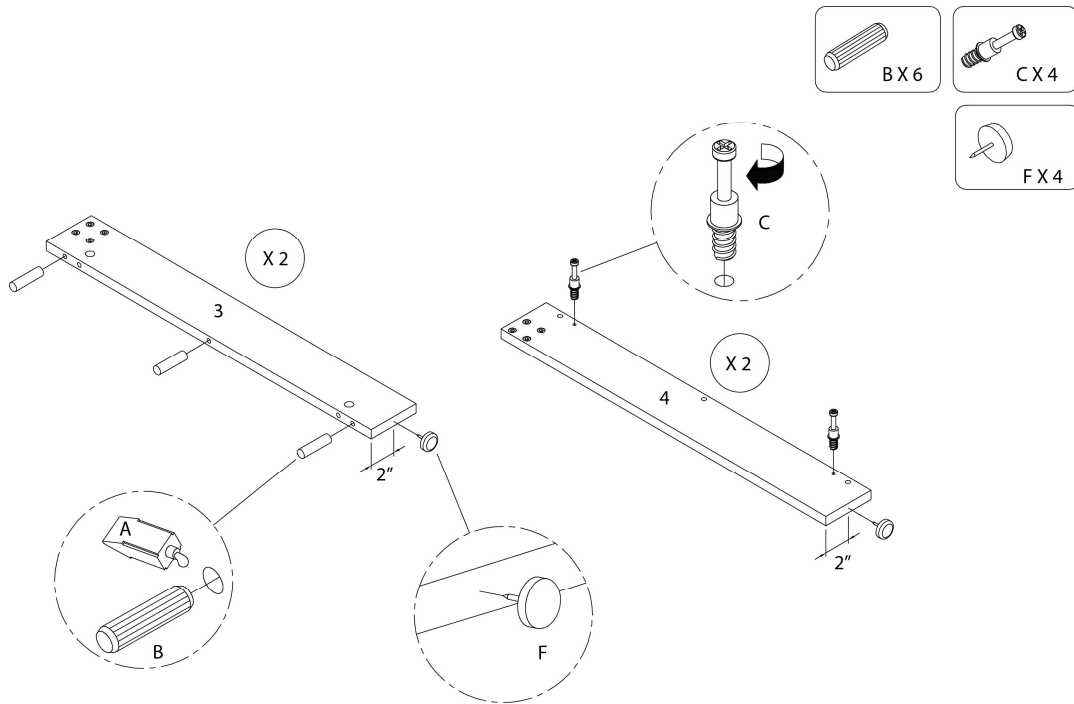

ÉTAPE / STEP 8

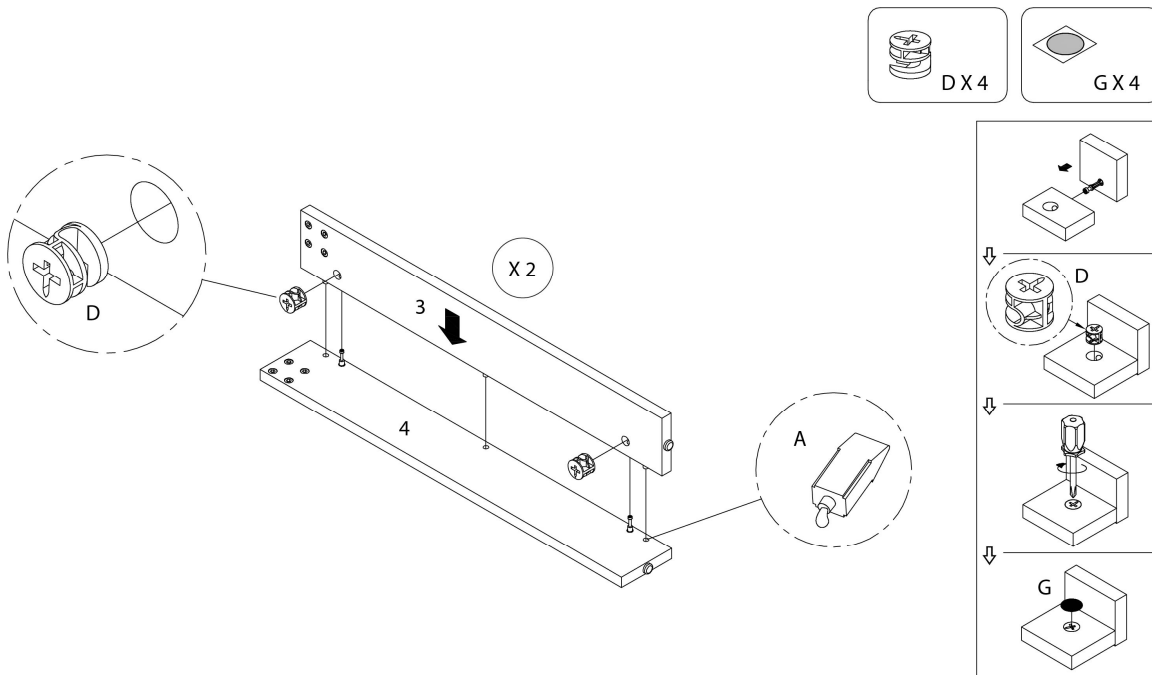

ÉTAPE / STEP 9

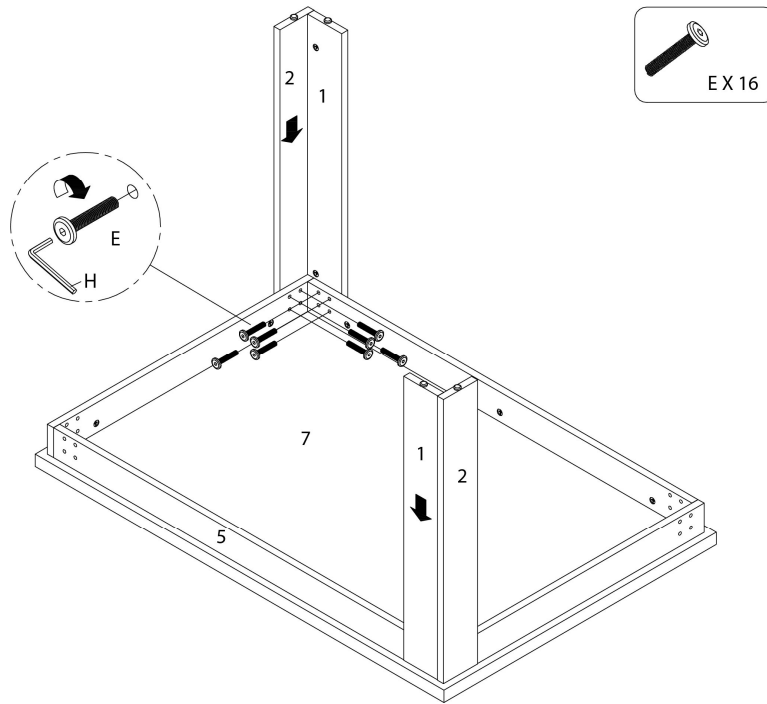

ÉTAPE / STEP 10

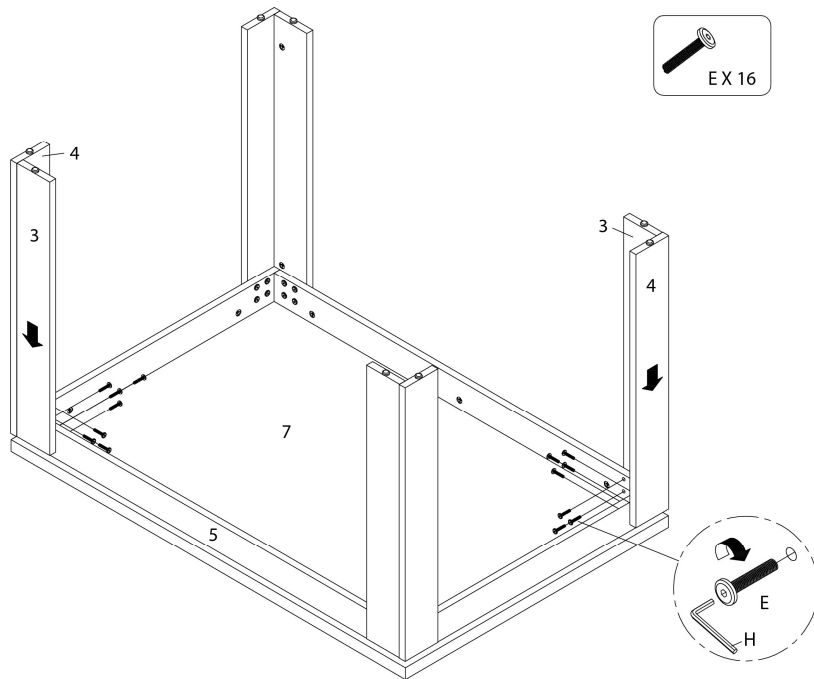

ÉTAPE / STEP 11

