

# ASSEMBLY INSTRUCTION (GRW)

Made In Malaysia

Thank you for purchasing this Product. We want to make sure it is complete and to your satisfaction. Please check all packing material carefully for small parts which may have come loose inside the carton during shipment. Hardware can be identified by red bright packaging. Separate, identify, and count all parts and hardware to make sure they match with the illustration herein and are all present, if any part(s) are missing or defective please contact Customer Service. Contact information is given at the bottom of these instructions. If you feel the item is defective beyond a resolution with part replacements, please return this product with your receipt to the place of purchase. If purchased from an internet retailer, please contact their customer service department. Photo's and additional information may be requested to validate the claim. Product is not to be returned to the company under any circumstance unless authorized by the Company or an authorized dealer or representative. Thank you.

**ATTENTION : SOME LETTERED PARTS ON THE INSTRUCTION SHEET MAY NOT BE IN PARTS BAG AS THEY MAY ALREADY BE ASSEMBLED. CAREFULLY CHECK PARTS AND PACKING MATERIAL PRIOR TO ORDERING REPLACEMENTS.**

Tools required for assembly : Allen Wrench (included).

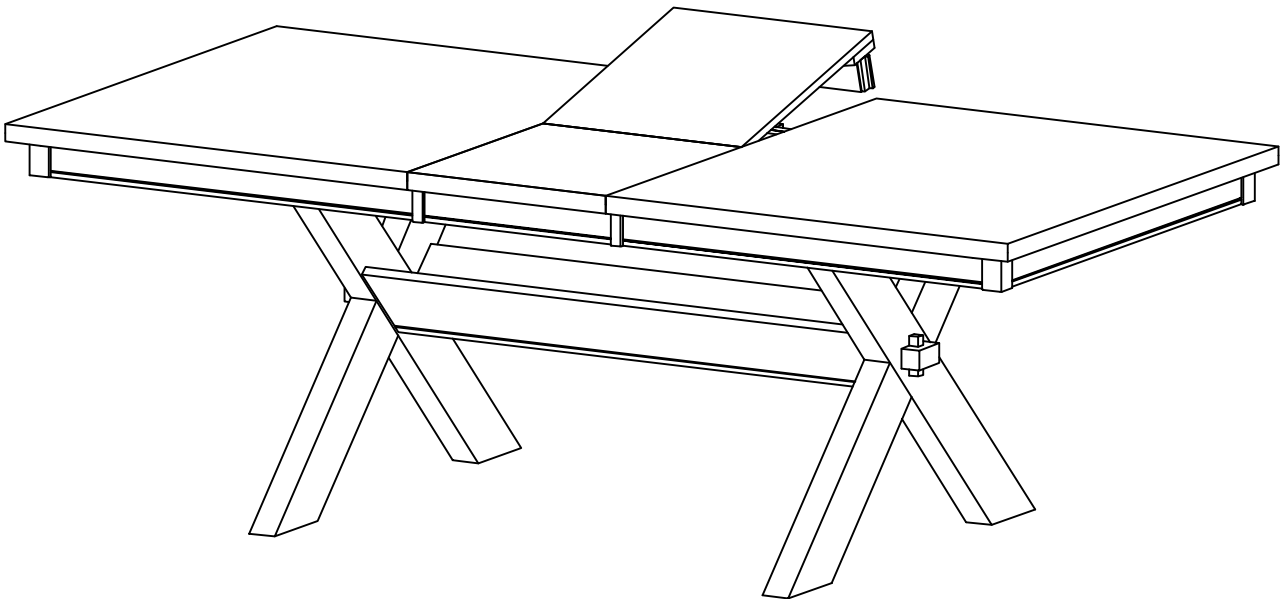

## PARTS

- (A) TABLE TOP (1)
- (B) RIGHT OUTER LEG (1)
- (C) RIGHT INNER LEG (1)
- (D) LEFT OUTER LEG (1)
- (E) LEFT INNER LEG (1)
- (F) STORAGE SHELF (1)
- (G) FINIAL (2)

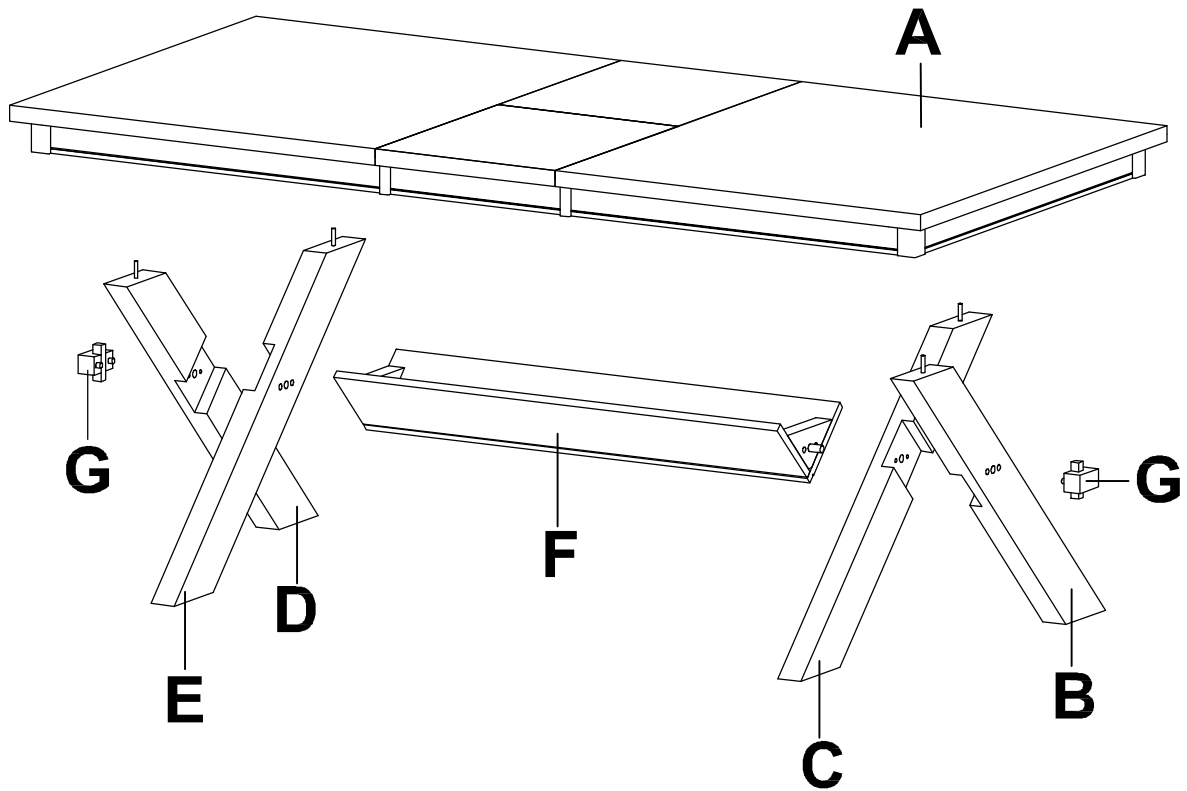

## HARDWARE



**I**  
(4 PCS)



**J**  
(4 PCS)



**K**  
(4 PCS)



**L**  
(1 PC)

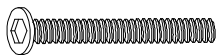

**M**  
(4 PCS)



**N**  
(4 PCS)



**O**  
(4 PCS)



**P**  
(1 PC)

**STEP 1**

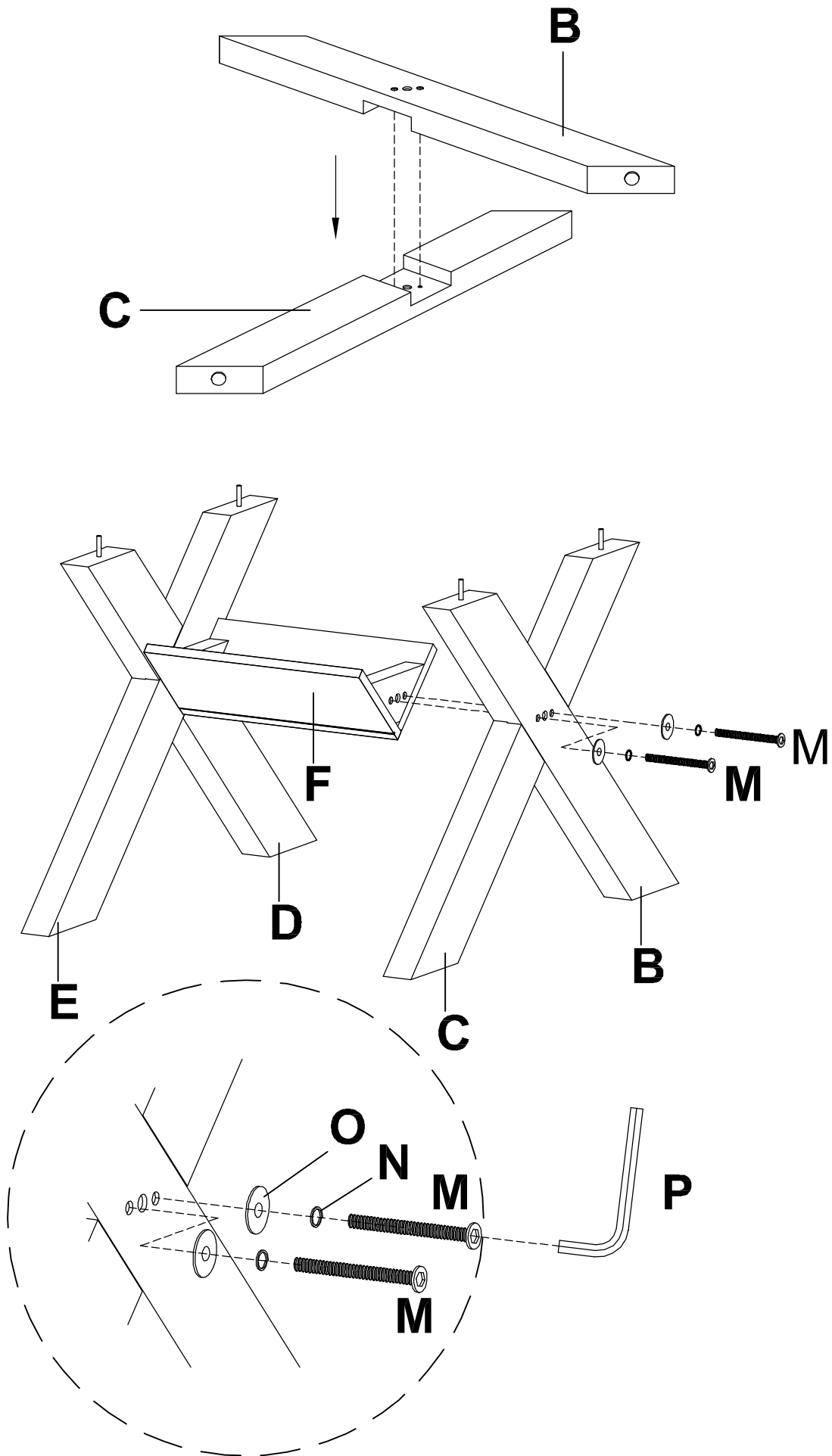

**STEP 2**

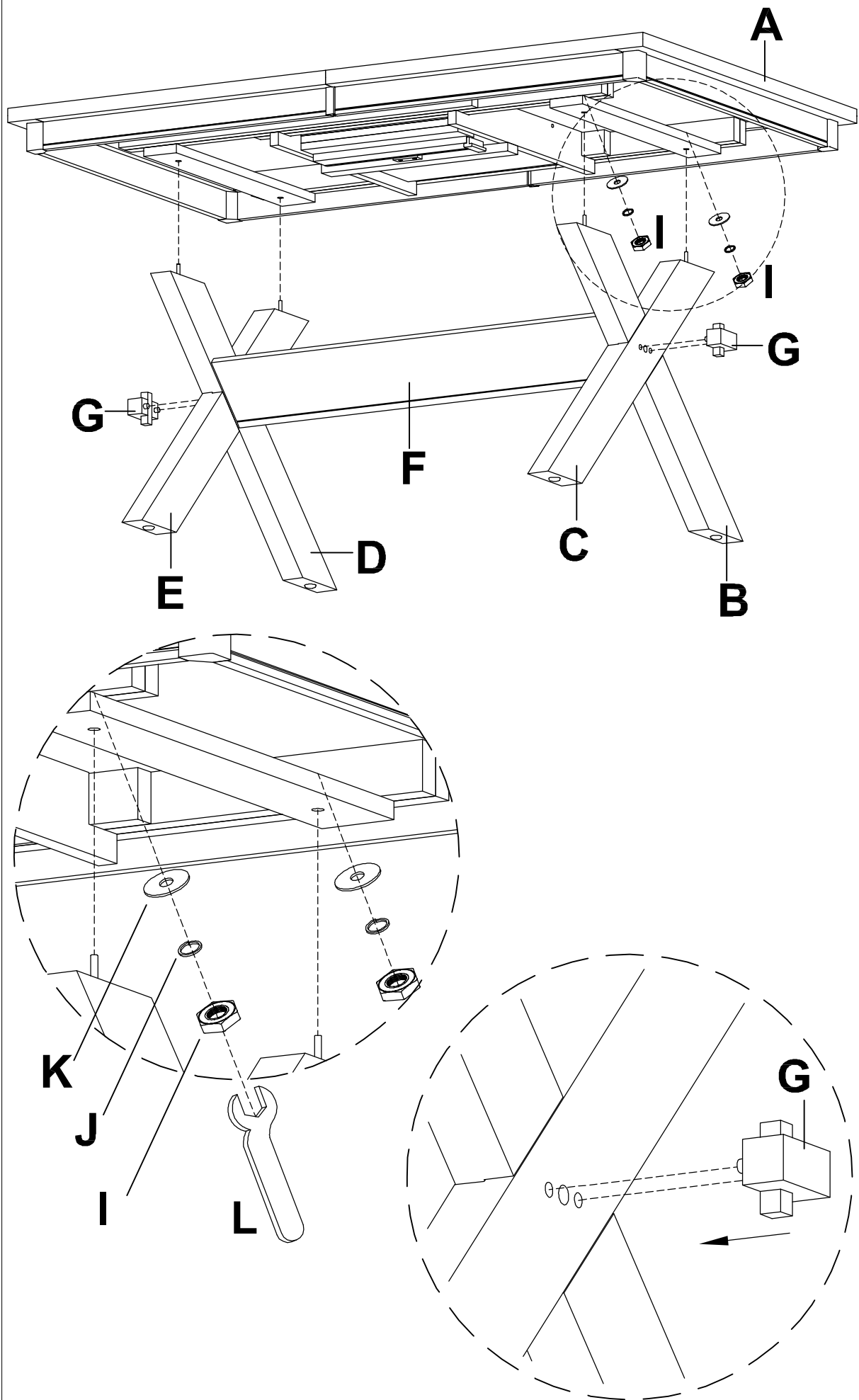

**STEP 3**

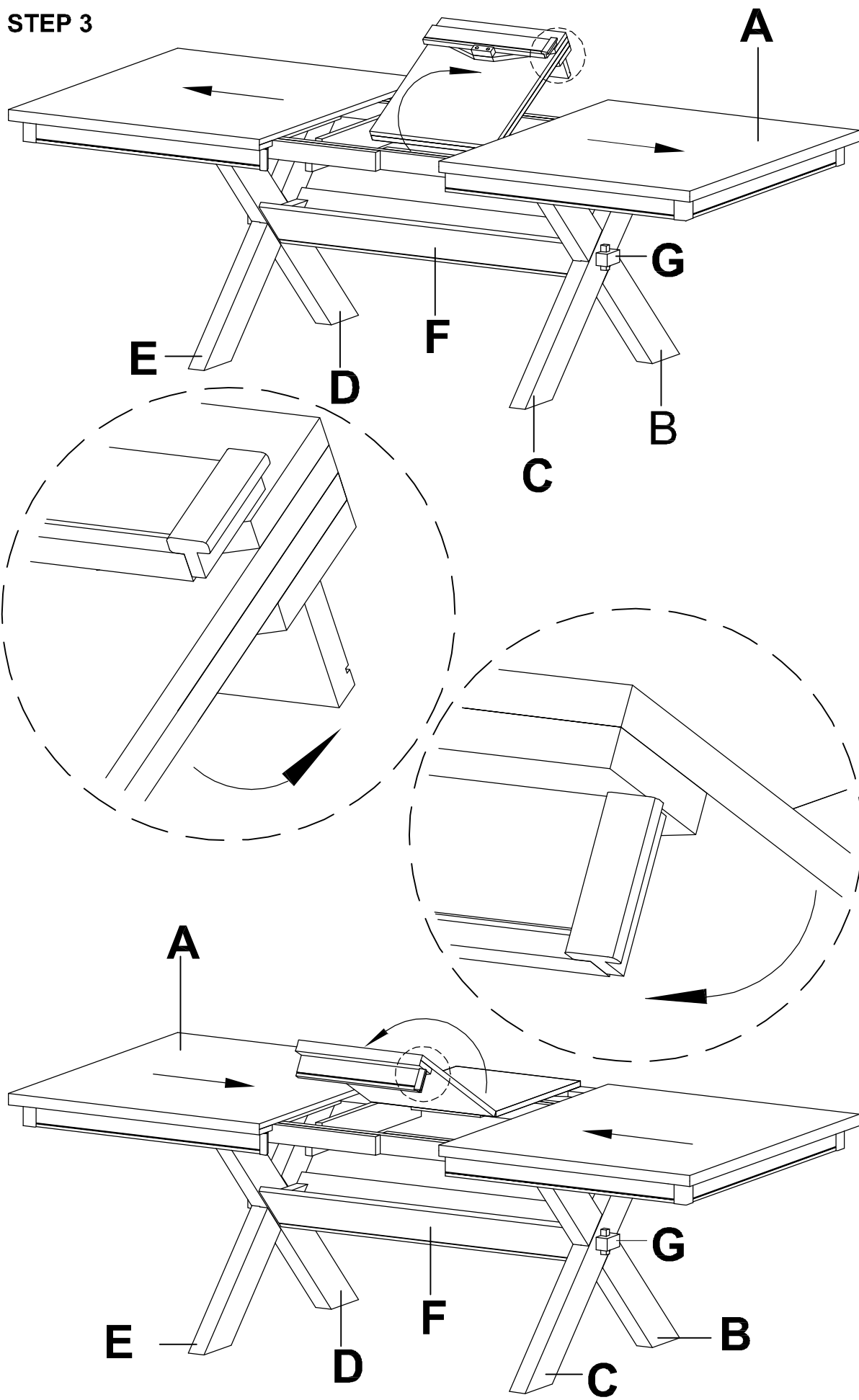

Made in Malaysia