

# ASSEMBLY INSTRUCTIONS

THANK YOU FOR PURCHASING THIS QUALITY PRODUCT.

BE SURE TO CHECK ALL PACKING MATERIAL CAREFULLY FOR SMALL PARTS THAT MAY HAVE COME LOOSE INSIDE THE CARTON DURING TRANSIT.

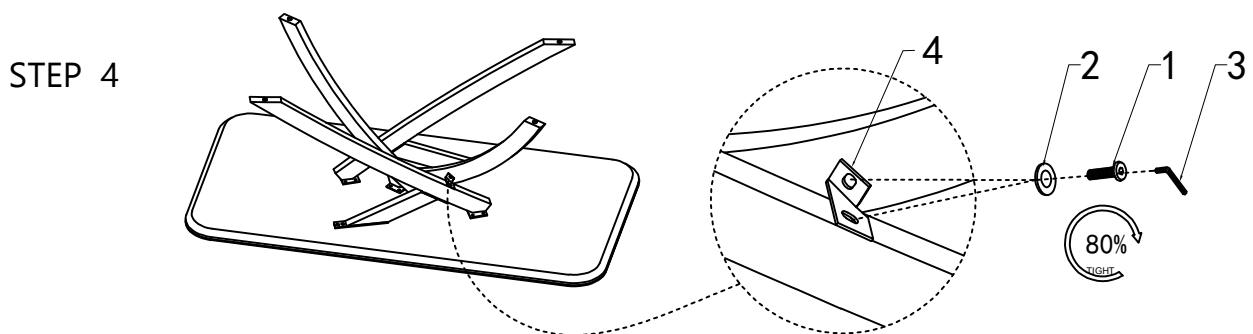
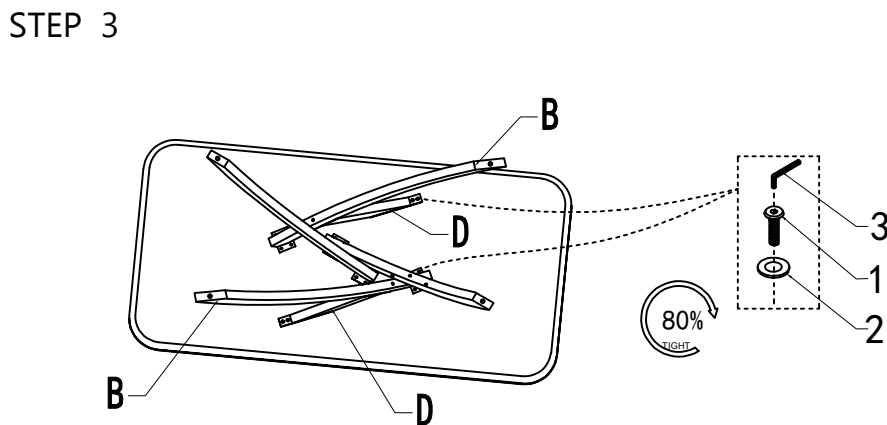
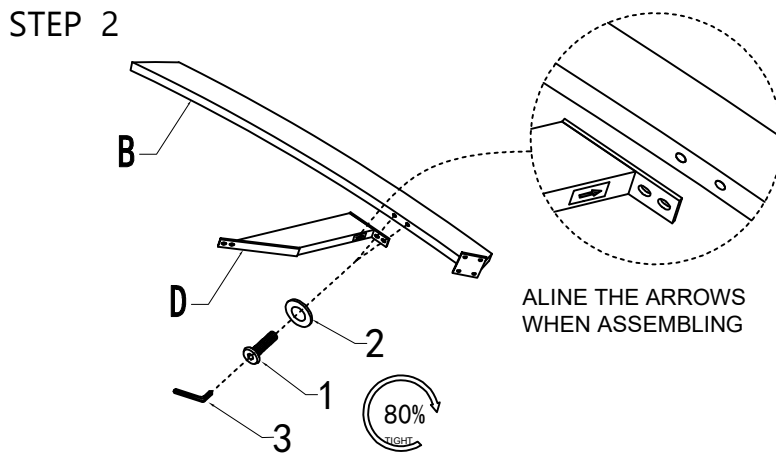
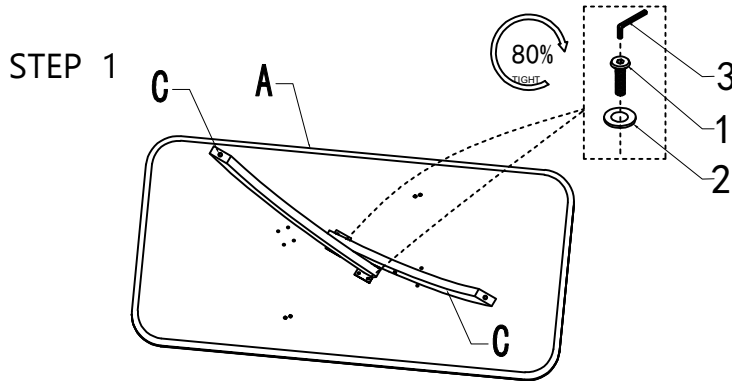

## PART LIST

NO	DESC	SIZE (MM)	SKETCH	QTY
A	TOP	2000*1000*45		1PC
B	LEG	1300*80*100		2PC
C	LEG	1125*80*100		2PC
D	PILLAR	560*60*20		2PC

## HARDWARE LIST

NO	DESC	SIZE(MM)	SKETCH	QTY
1	BOLT	M8x20		28PCS
2	FLAT WASHER	Ø8.3		28PCS
3	SPANNER	5#		1PC
4	BRACKET	70*40*35		2PCS

## ASSEMBLY INSTRUCTIONS

THANK YOU FOR PURCHASING THIS QUALITY PRODUCT.

BE SURE TO CHECK ALL PACKING MATERIAL CAREFULLY FOR SMALL PARTS THAT MAY HAVE COME LOOSE INSIDE THE CARTON DURING TRANSIT.

### STEP 5

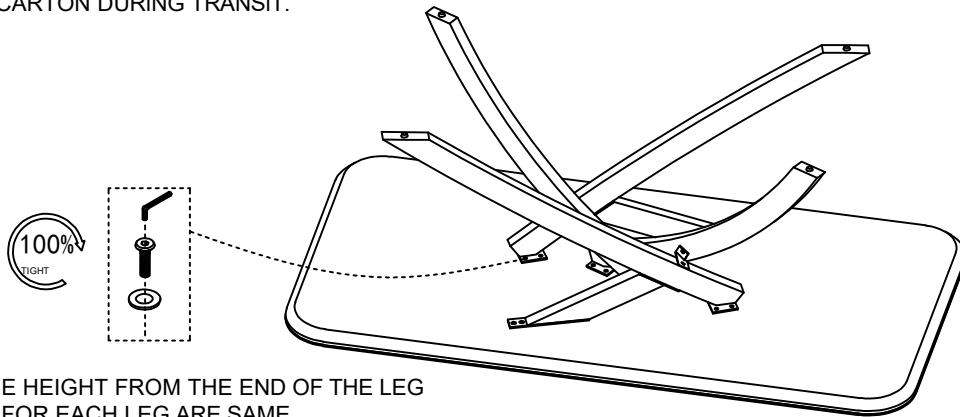

MAKE SURE THE HEIGHT FROM THE END OF THE LEG TO TABLE TOP FOR EACH LEG ARE SAME, THEN TIGHTEN ALL THE SCREWS ON THE LEGS.

### STEP 6

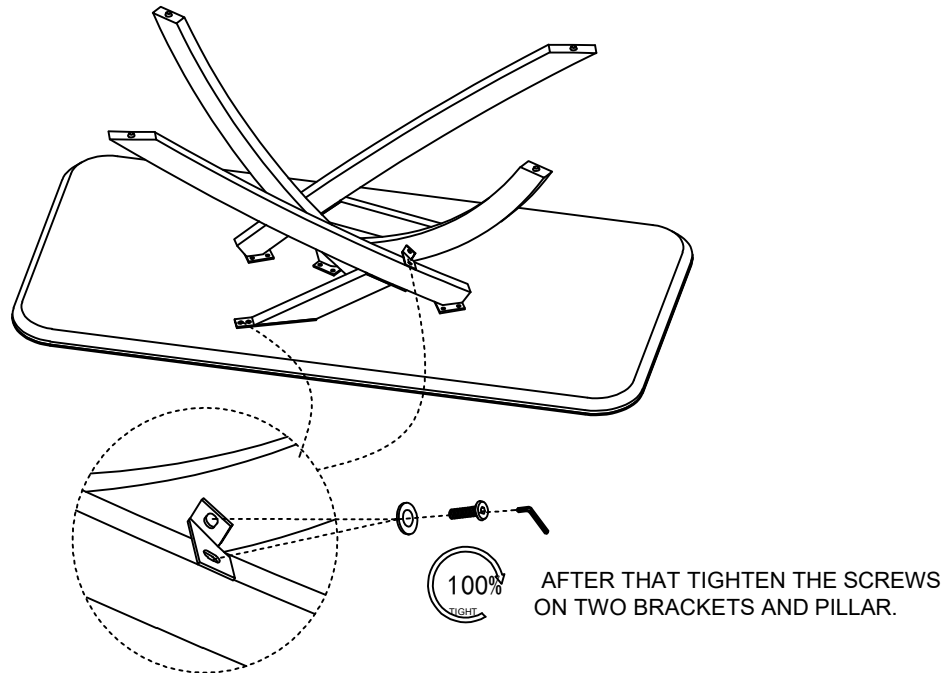

AFTER THAT TIGHTEN THE SCREWS ON TWO BRACKETS AND PILLAR.

### FINISHED

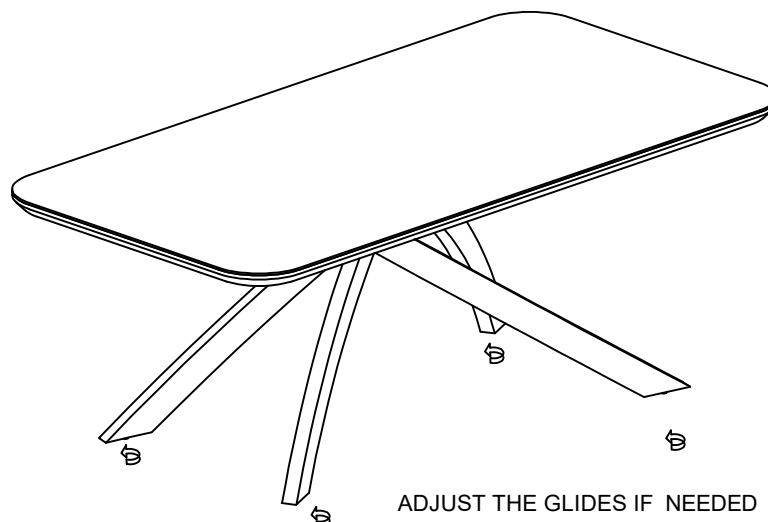

ADJUST THE GLIDES IF NEEDED