

# Assembly Instructions

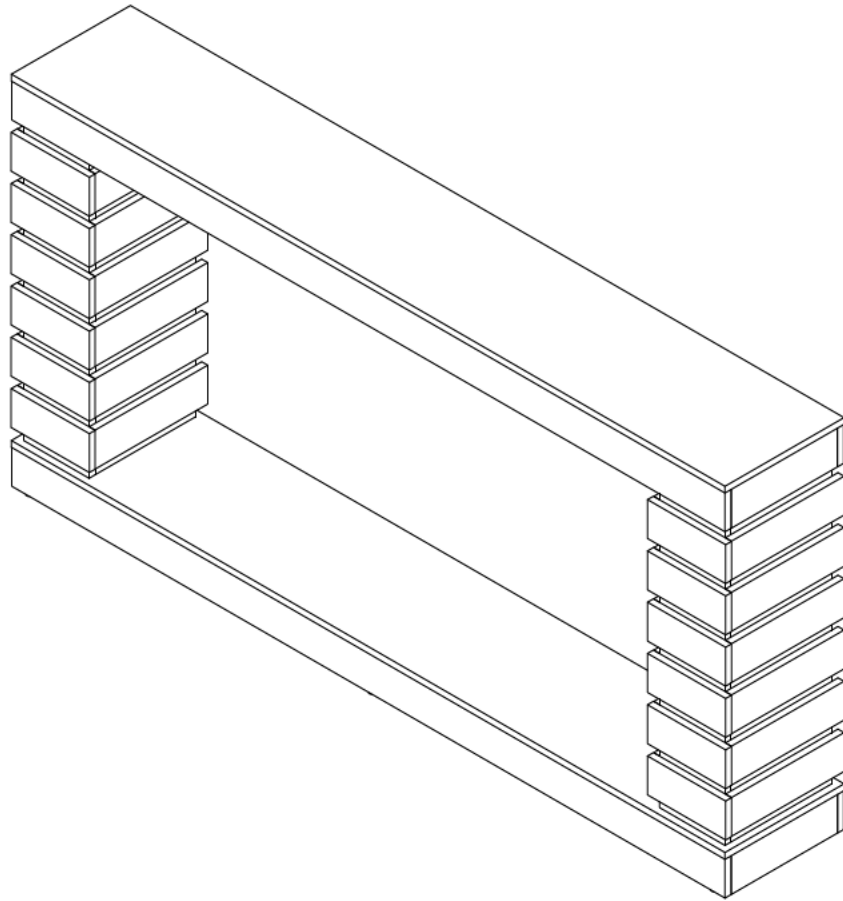

Your satisfaction is our top priority. If you encounter any issues with this product, such as missing or damaged parts, we're here to help. Please retain the original packaging and take photos of the packaging and the product, then contact us as soon as possible.

## **Warm Tips**

1. Carefully read these instructions and keep them for future reference.
2. Check the parts list and confirm everything's there before starting assembly.
3. When assembling, put all parts on a soft, smooth surface like a carpet to avoid scratches.
4. Don't fully tighten screws until all parts are confirmed in place to avoid misalignment.

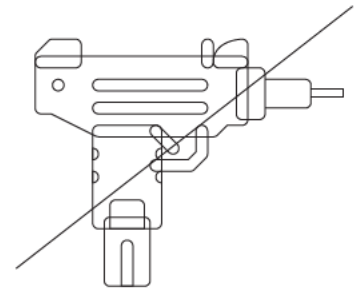
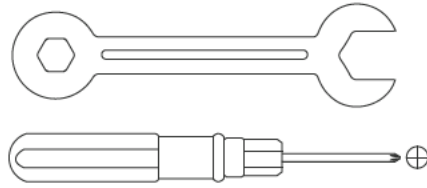
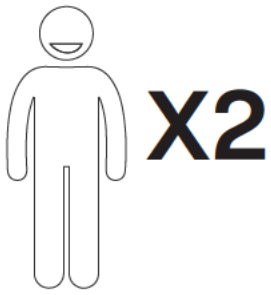

We recommend using hand tools for assembly.

If an electric screwdriver is used, reduce power and torque to avoid damage to the product.

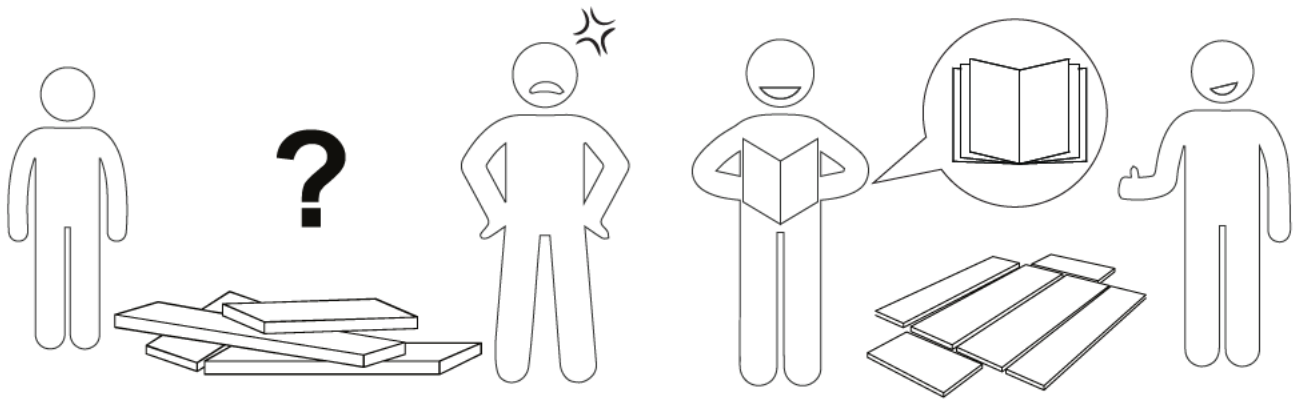

## Install the Anti-Tip Straps

Using the anti-tip straps can reduce the risk of tipping over, but can not eliminate it.

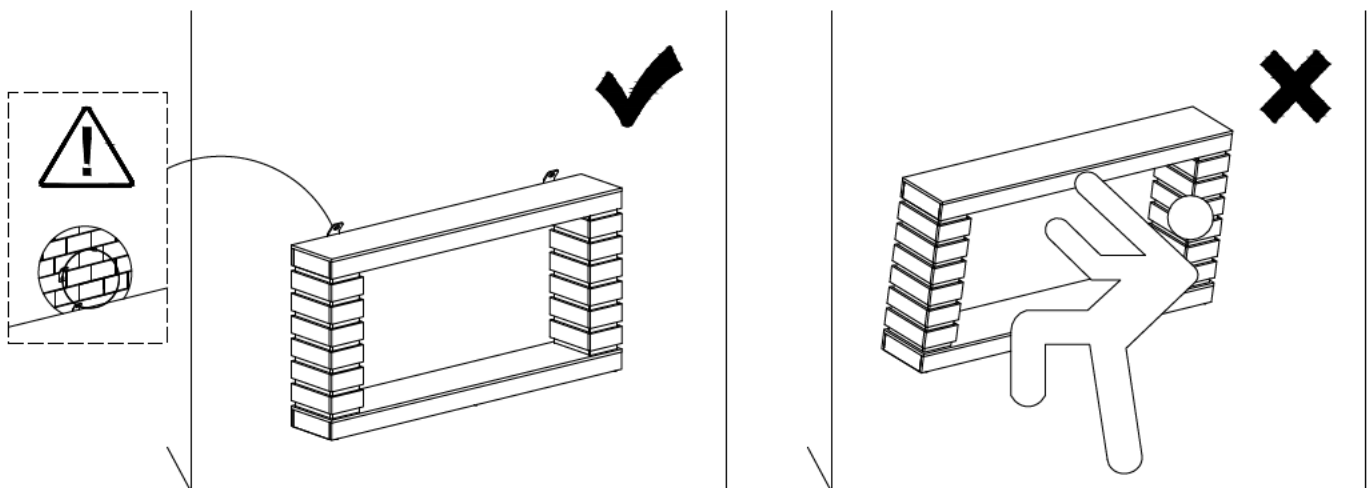

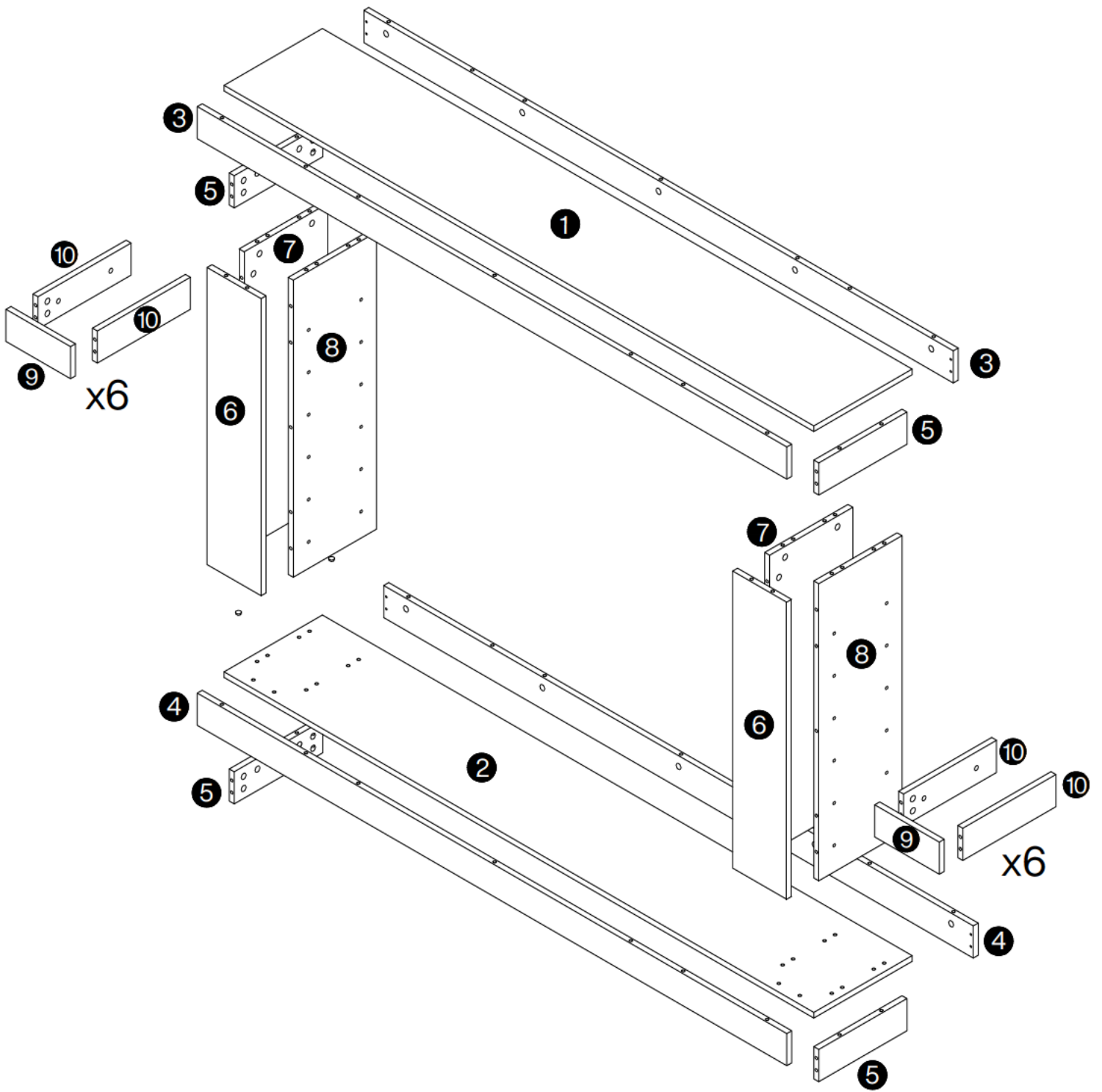

**⚠ Caution**

Make sure all parts are included. Most board parts are labeled or stamped on the raw edge. Contact us for a free replacement if you encounter any damaged or missing parts.

# Parts List

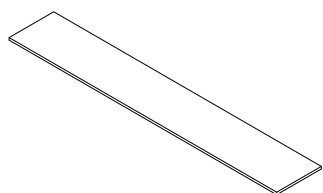

① 1pc

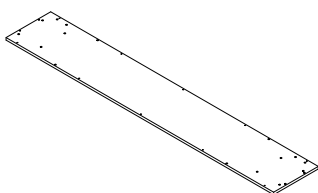

② 1pc

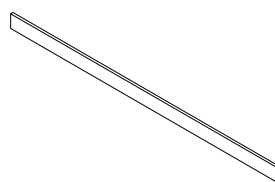

③ 2 pcs

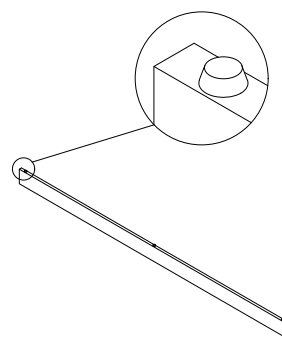

④ 2 pcs

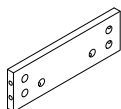

⑤ 4 pcs



⑥ 2 pcs

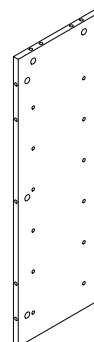

⑦ 2 pcs



⑧ 2 pcs

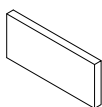

⑨ 12 pcs

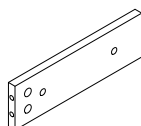

⑩ 24 pcs

# Hardware List

A	X116+1	B	X116+1	C	X32+1	D	X12+1	E	X48+1	F	X2+1
Ø6X35 mm		Ø15X12 mm		Ø8X30 mm		M7X47 mm		M6X25 mm		Ø3.5X14 mm	

G	X2+1	H	X2	I	X2	J	X1	K	X4
Ø4X35 mm		L250 mm		Ø8X40 mm		M4X64 mm		26X13 mm	

# Installation of Cams and Pins

Read each step carefully before starting. Each step of instruction should be performed in the correct order. If these steps are not followed in sequence, assembly difficulties may occur.

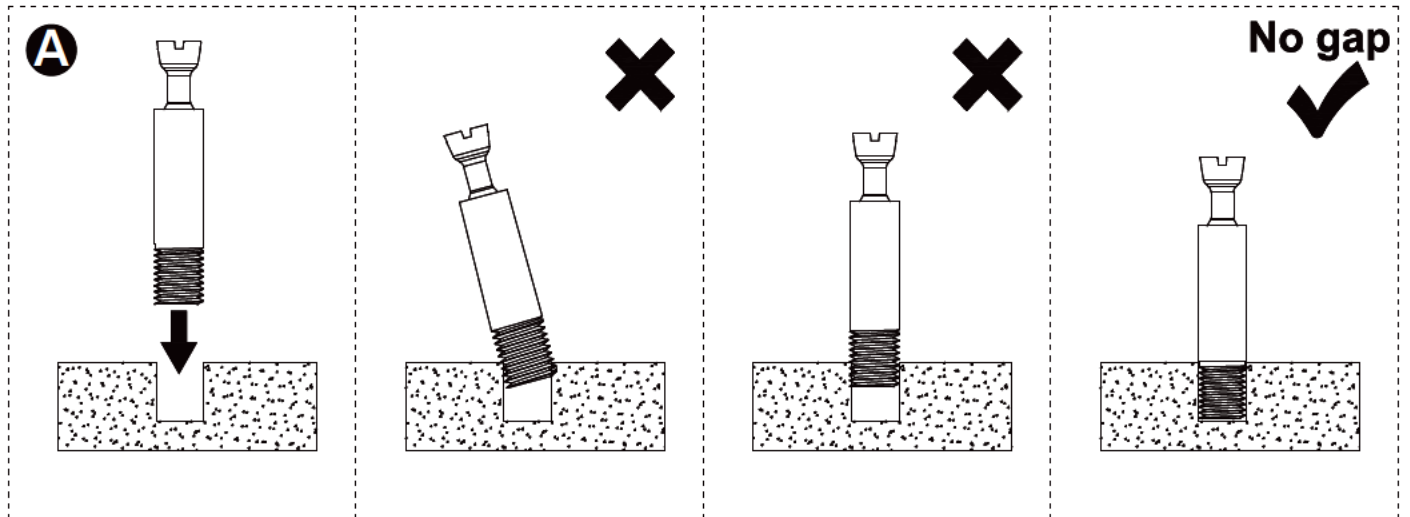

Screw the pin into the hole. Set the cams correctly by aligning the head of the cams with the lock pins. Lock the cam by turning the cam head with a screwdriver until it is tightened. Please do not use an electric screwdriver to assemble the unit.

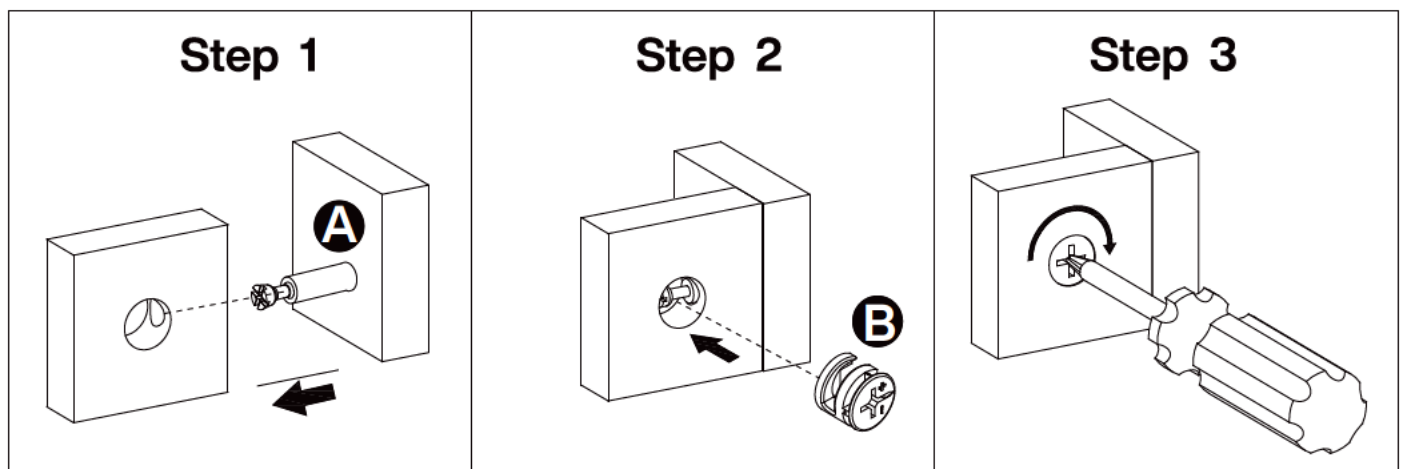

**1**

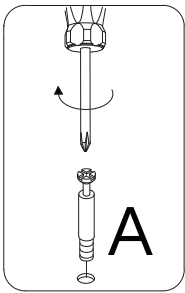
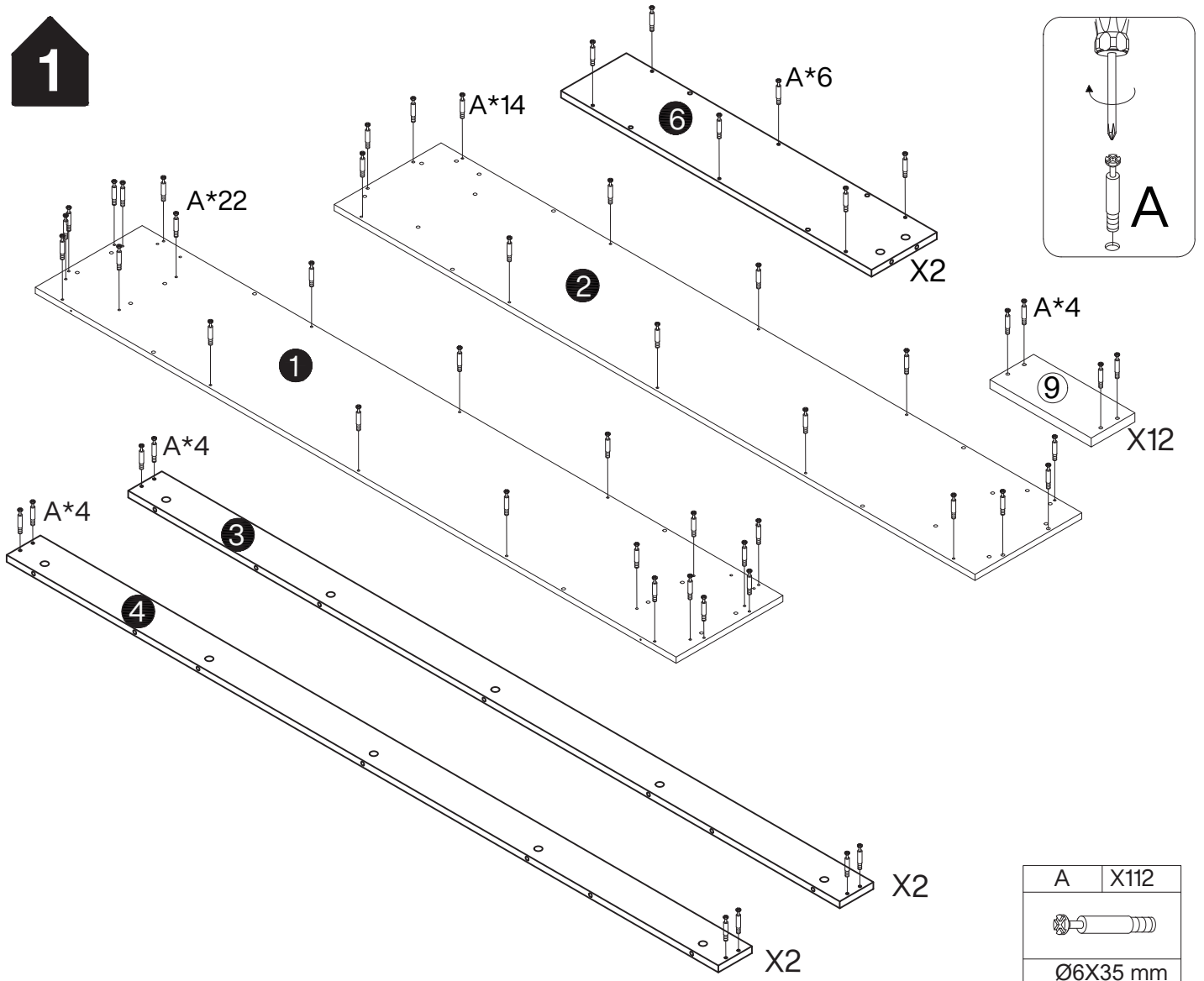

A	X112
Ø6X35 mm	

**2**

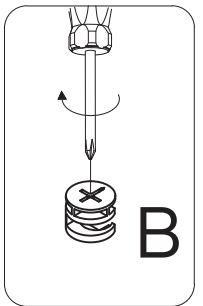
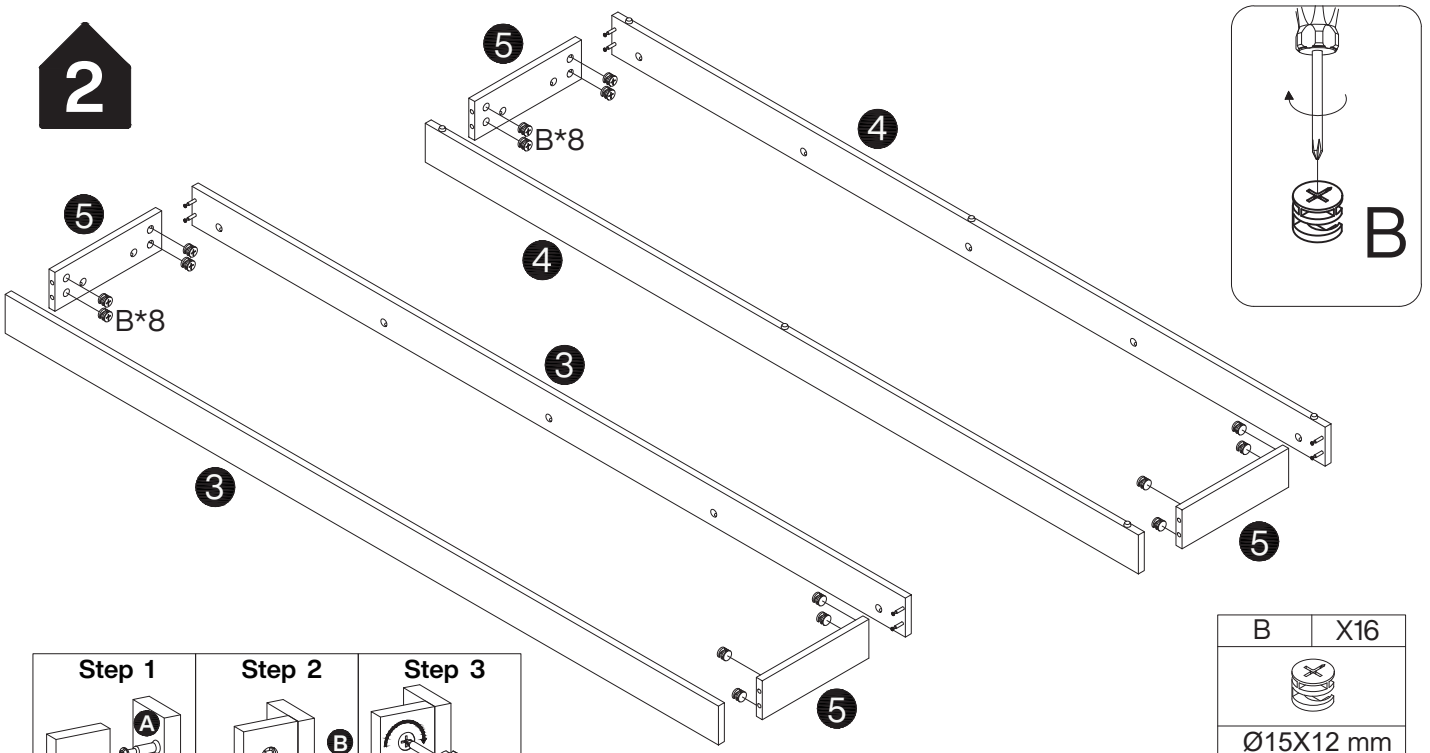

B	X16
Ø15X12 mm	

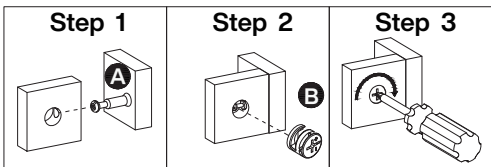

# 3

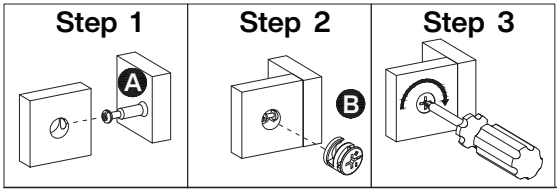
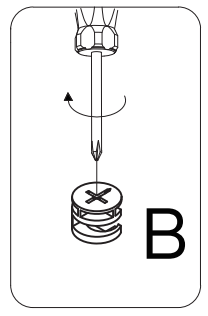
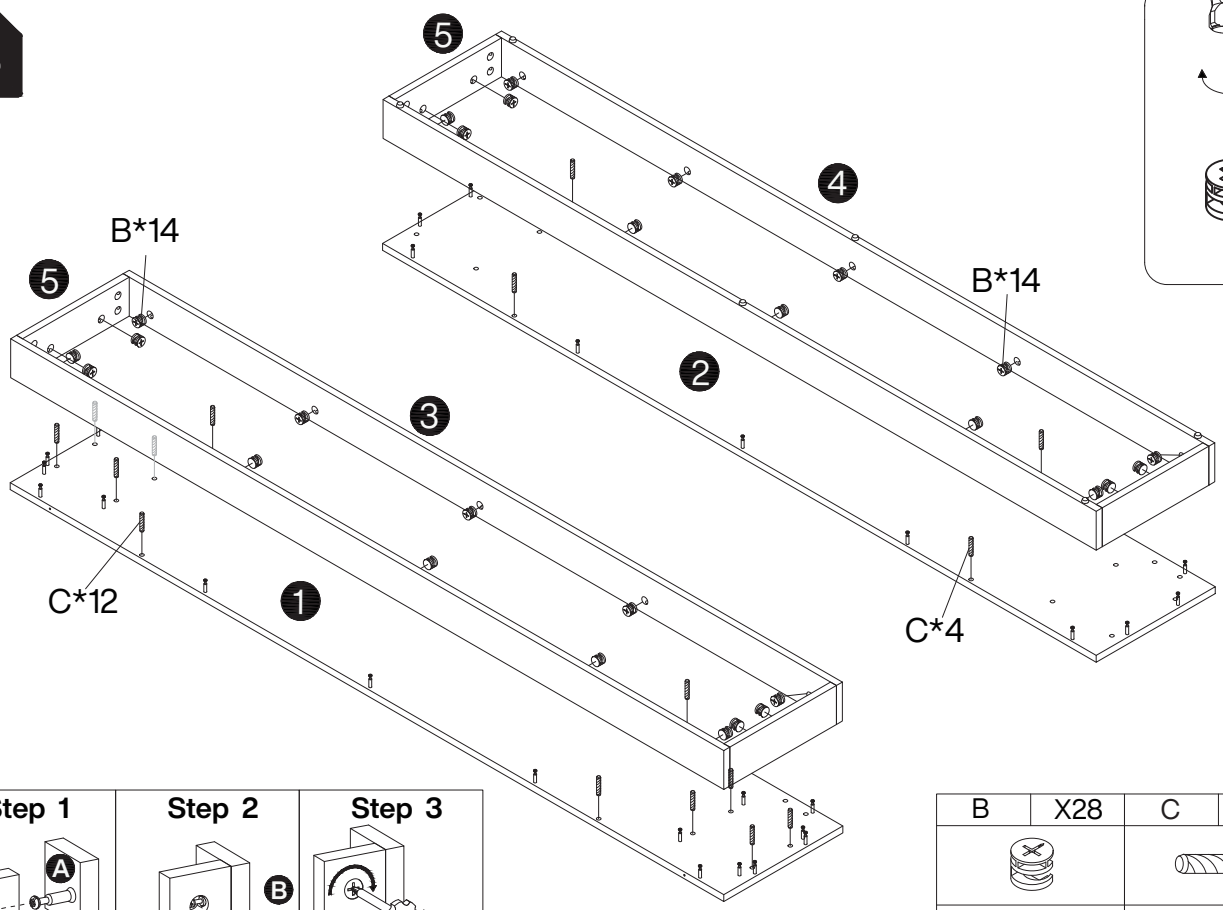

B	X28	C	X16
Ø15X12 mm		Ø8X30 mm	

# 4

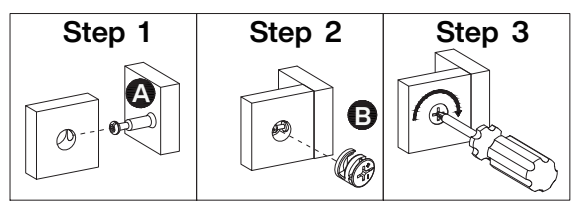
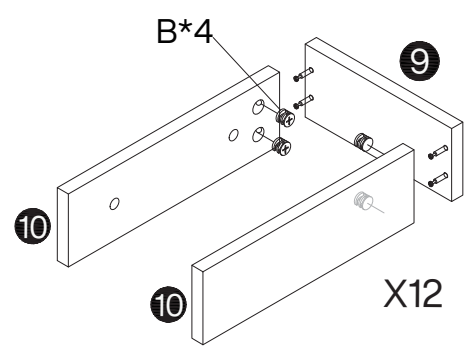
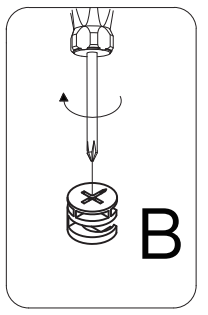
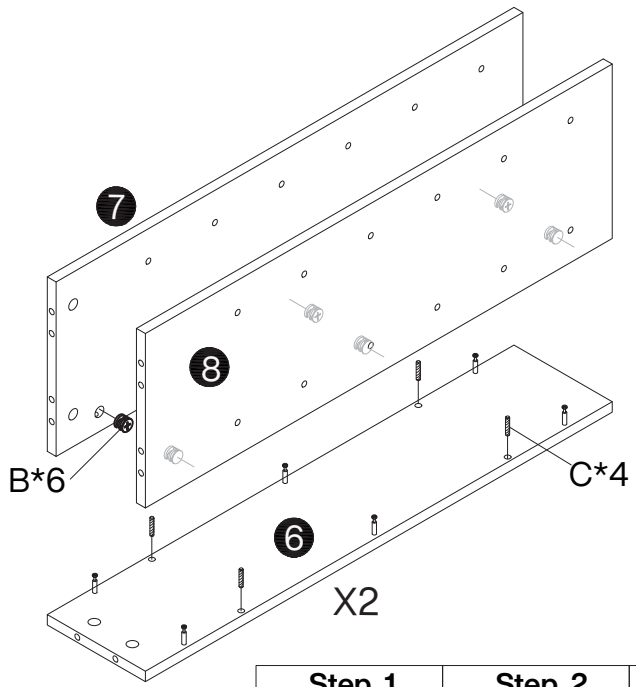

B	X60	C	X8
Ø15X12 mm		Ø8X30 mm	

# 5

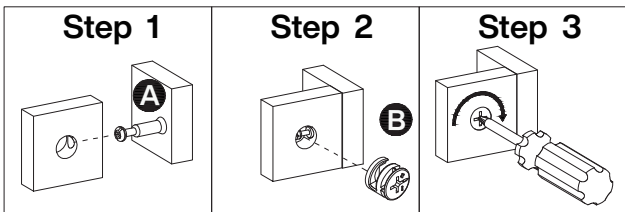
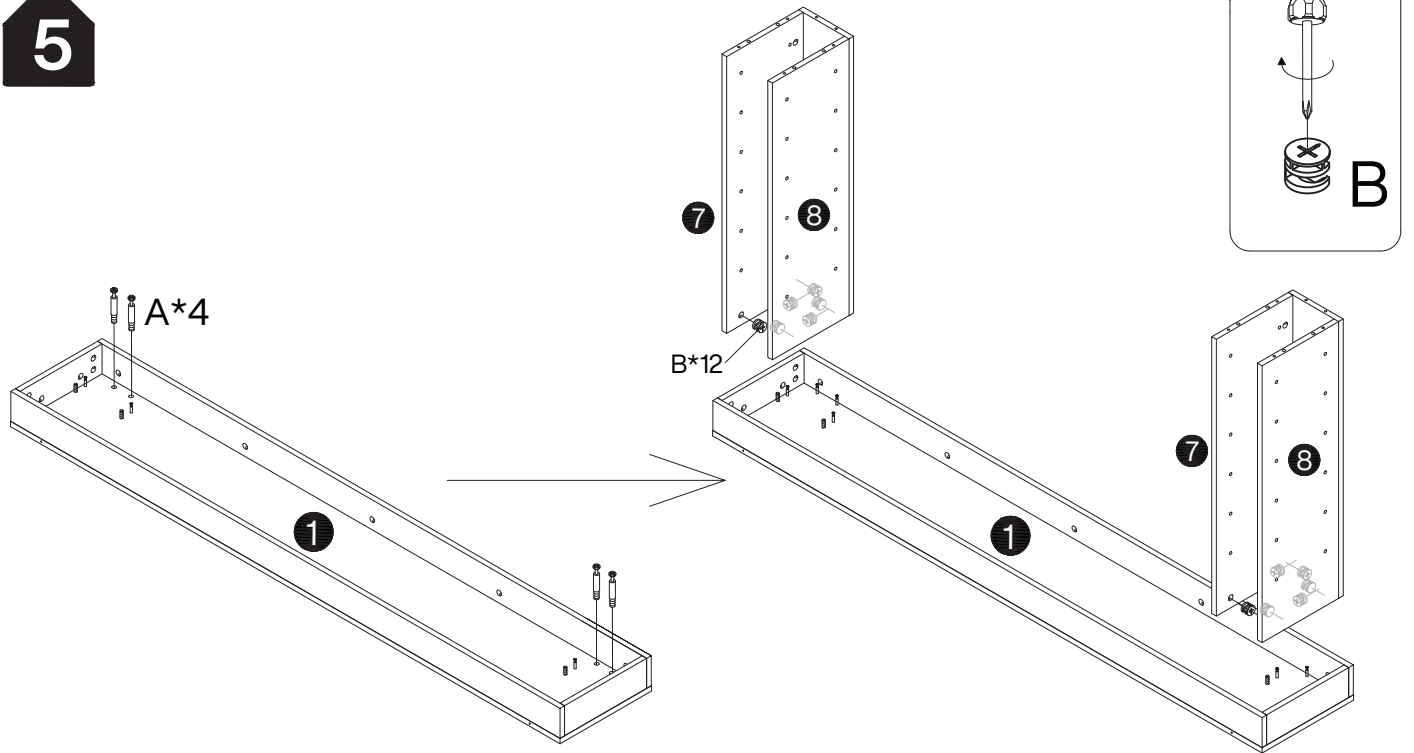

A	X4	B	X12
Ø6X35 mm		Ø15X12 mm	

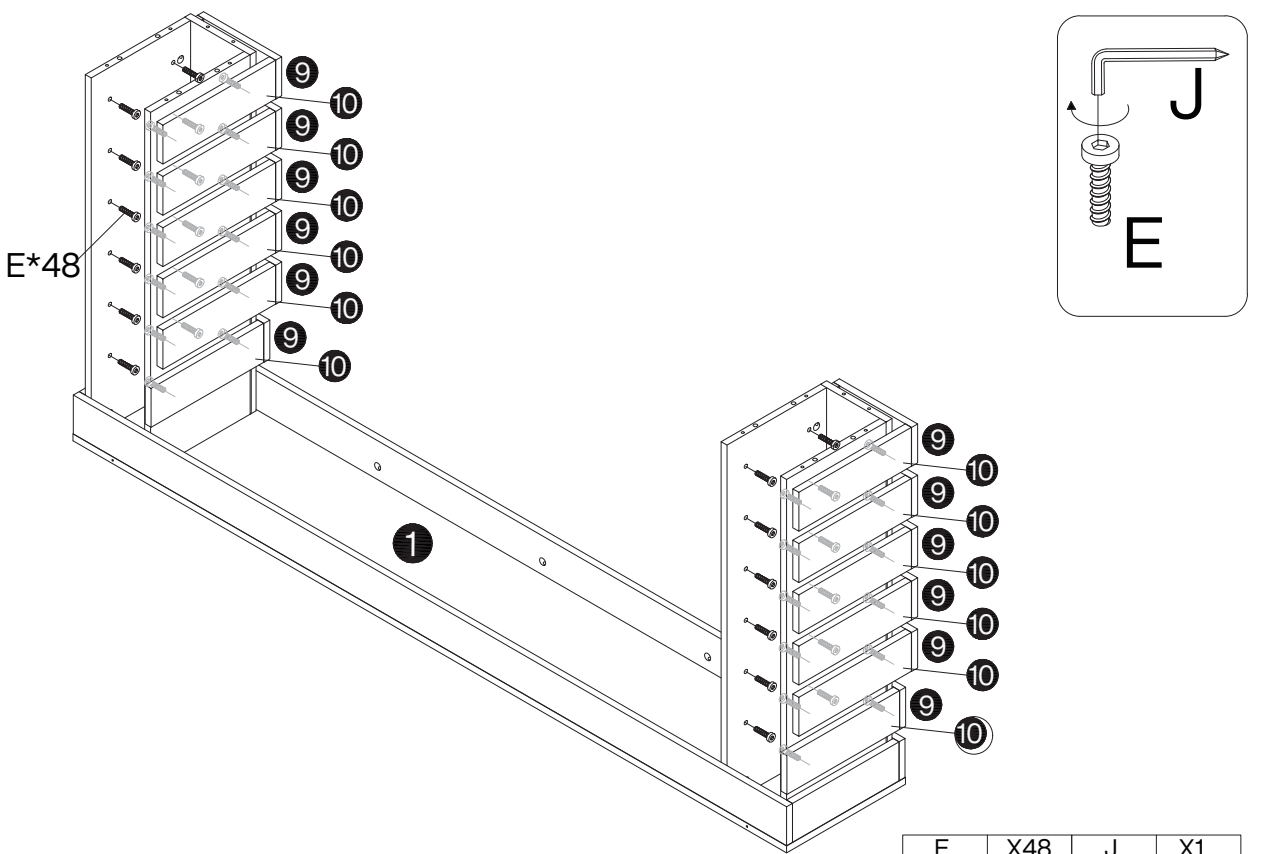

# 6



E	X48	J	X1
M6X25 mm		M4X64 mm	

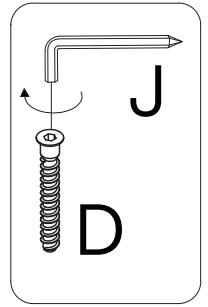
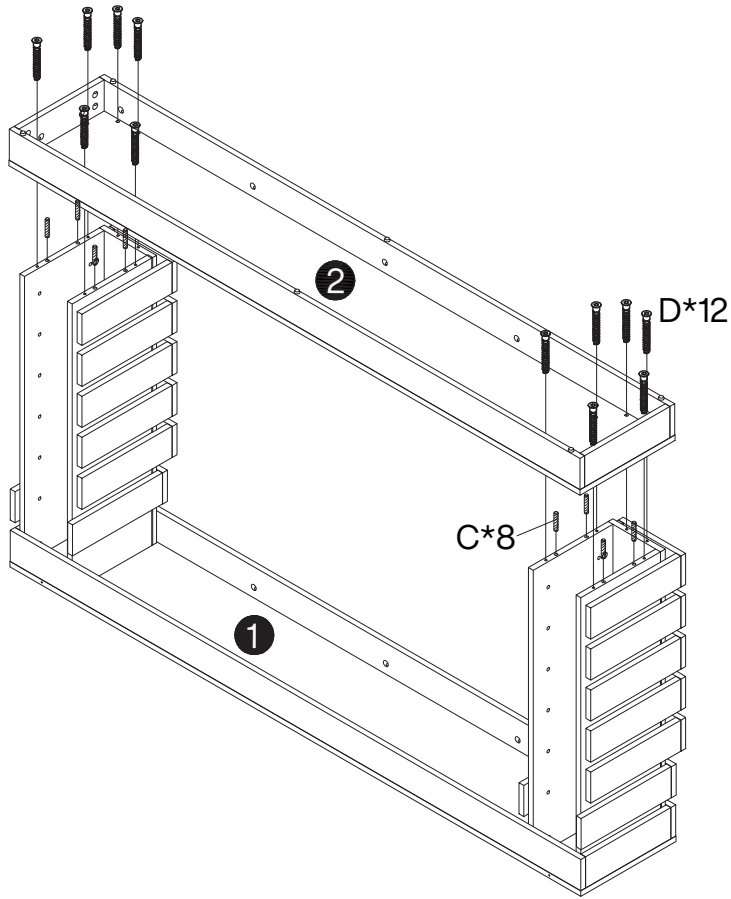

7



C	X8	D	X12
			
Ø8X30 mm		M7X47 mm	

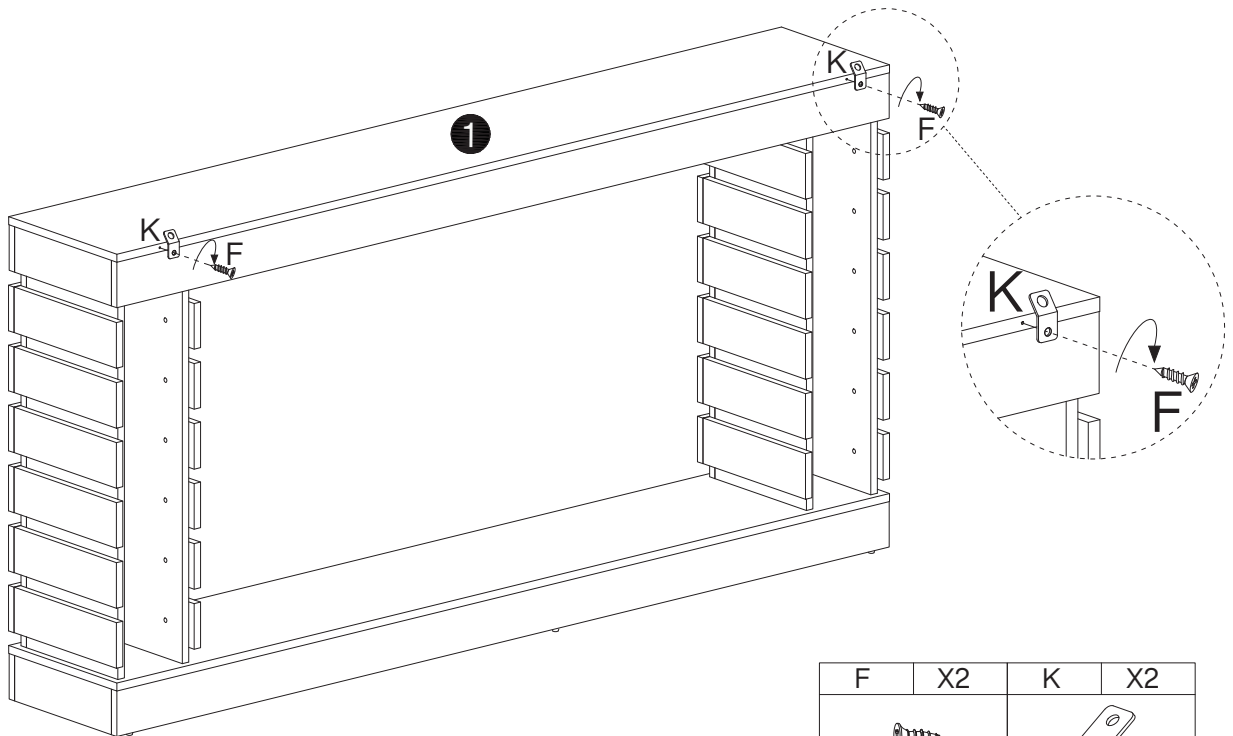

8

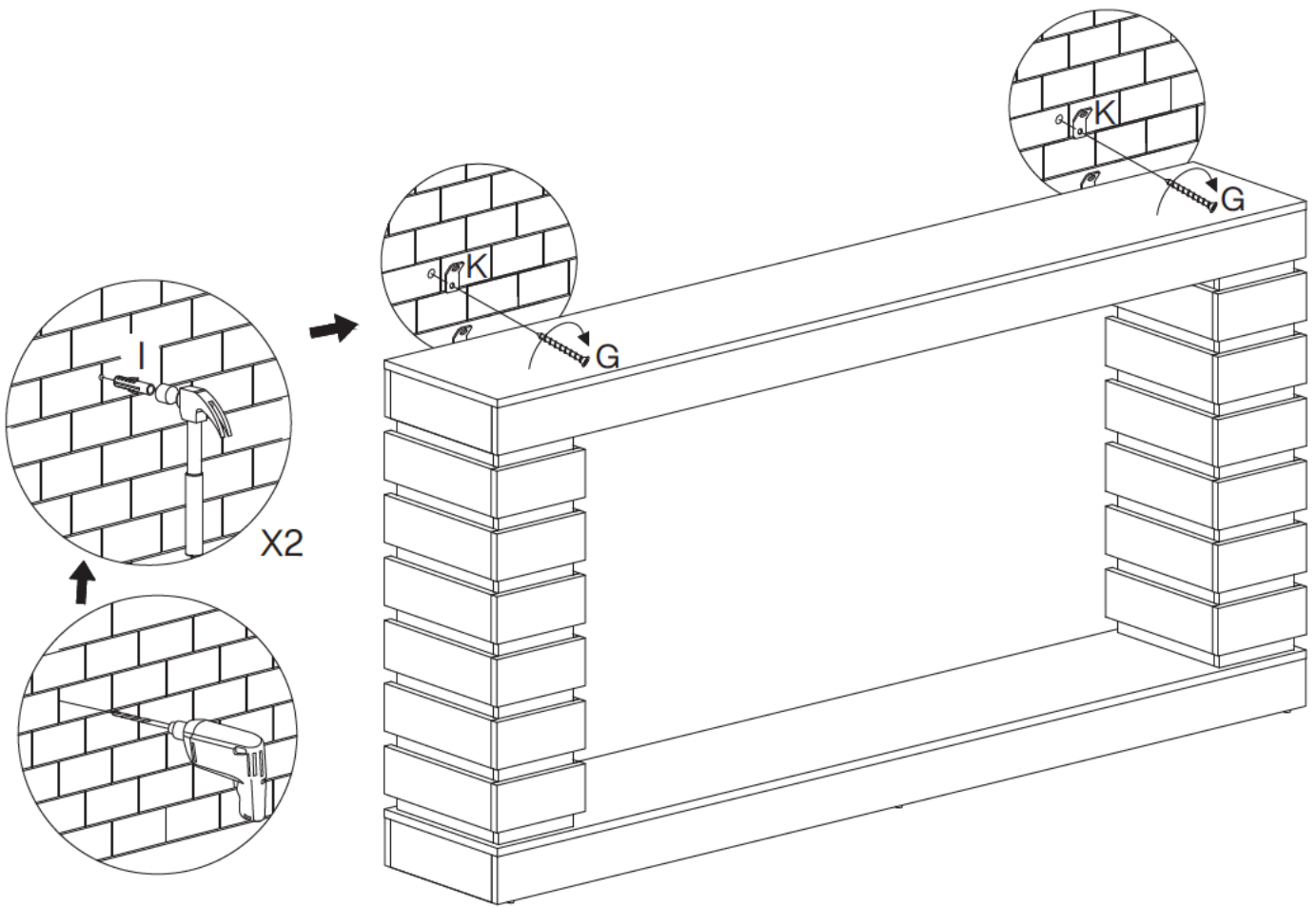

F	X2	K	X2
			
Ø3.5X14 mm		26X13 mm	

# 9



G	X2	I	X2	K	X2
					
Ø4X35 mm		Ø8X40 mm		26X13 mm	

10

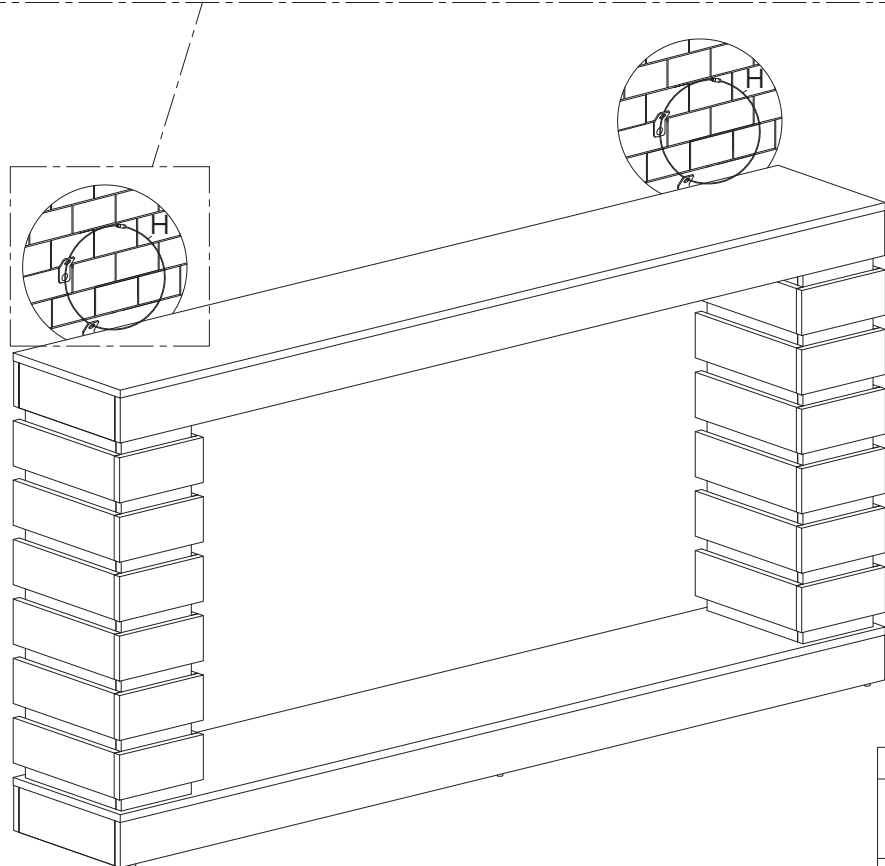
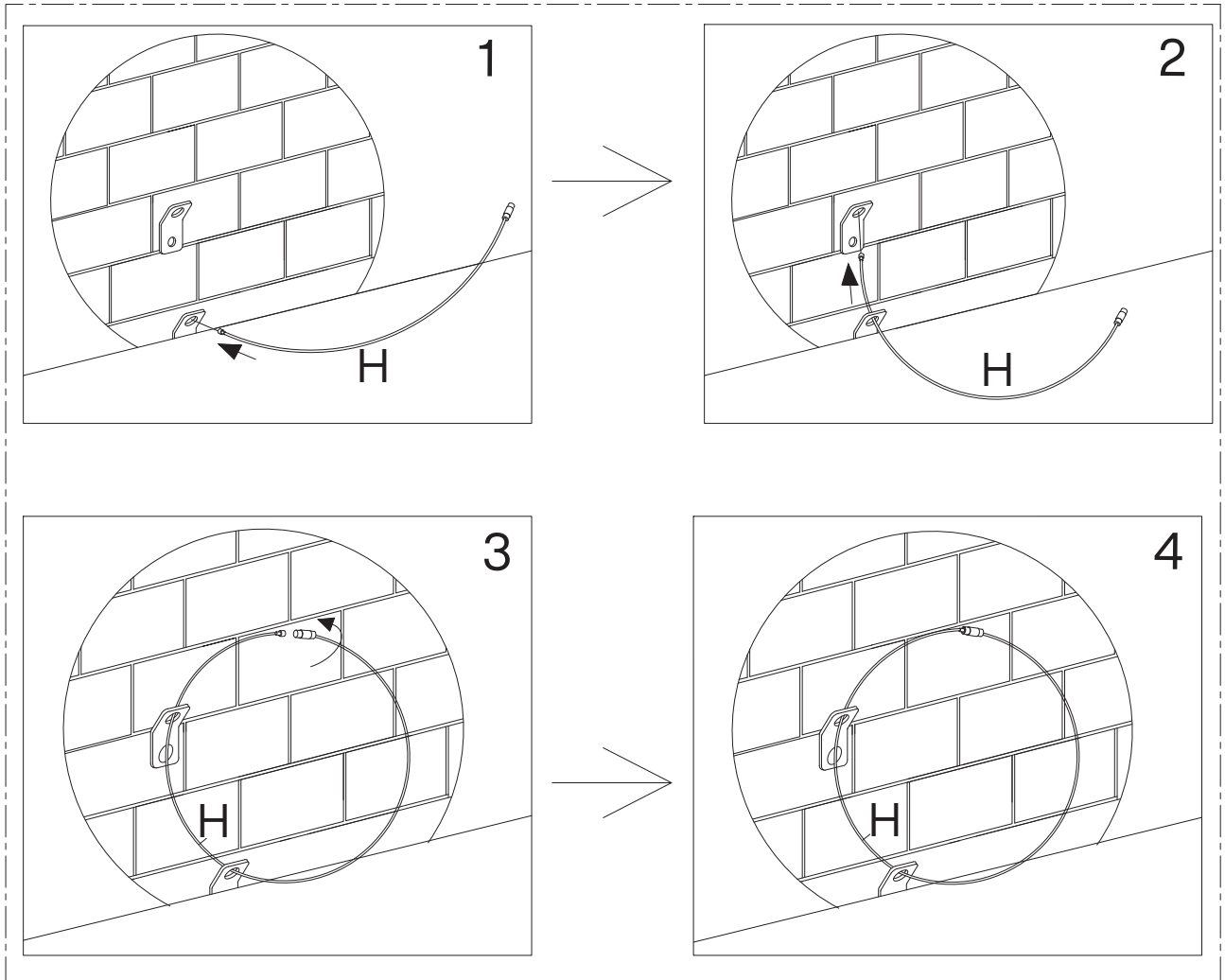

H	X2
	
L250 mm	

**Thank you for your support!**

