

## NOTICE

---

- \* Please make sure that you have all parts indicated and they are in good condition before you begin assembly of this item. Refer to part list and hardware list below for guidance.
- \* This item should be assembled on a soft surface to prevent scratching the finish during assembly.
- \* This item may require periodic tightening.
- \* If you are having difficulty, our friendly Customer Care team is always here to help.

## PREPARATION

---

- \* Before beginning assembly of product, make sure all parts are present. Compare parts with part contents list and hardware contents list.
- \* If any part is missing, do not attempt to assemble the product.
- \* Estimated Assembly Time: 10 minutes.
- \* Tools Required for Assembly (included): Spanner

## CARE AND MAINTENANCE

---

### WOOD CARE

Adhesive felt pads should always be applied to areas of furniture which make direct contact with flooring, said application will prevent damage to the furniture and or surfaces on which the furniture lies. Objects placed on articles of furniture should rest on nonabrasive material as to prevent damage to the wood finish. Wipe up spills immediately and avoid common hazards such as hot dishes, harsh solvents and abrasives. Cleaning should be done with a soft lint free cotton cloth dampened with water or furniture polish.

### WICKER

Dust regularly with small brush or vacuum. Spills should be taken care of immediately before they harden or stain, by wiping with a soft, damp cloth. Do not rinse with high pressure hose. Use a sponge with mild detergent and warm water to remove hard stain or soil. Allow it air dry completely in a shady spot before re-using.

# Owner Manual

**ITEM DIMENSIONS: 18.1"W X 22.8"D X 39"H**

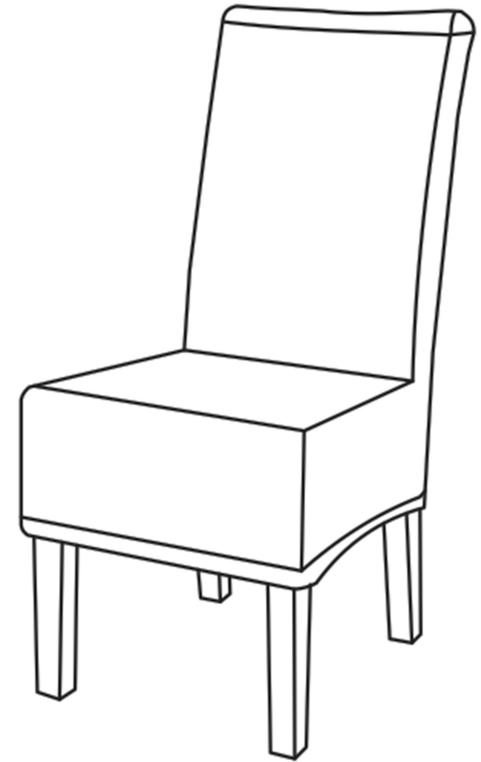

**WARNING**









**Weight Capacity – 225 lbs**

**WARNING: DO NOT STAND ON THE CHAIR**

**WARNING: DO NOT OVER TORQUE BOLTS**

## Part List and Hardware List

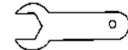
PIECE	DESCRIPTION	PICTURE	QUANTITY
A	Seat		1X
B	Back Legs		1X
C	Front Leg-1		1X
D	Front Leg-2		1X
E	Black Fabric		1X
HW1	Bolt 8 X 60 mm		6X
HW2	Flat Washer		6X
HW3	Spanner		1X

# PREPARATION

- \* Before beginning assembly of product, make sure all parts are present. Compare parts with part contents list hardware contents list.
- \* If any part is missing or damaged, do not attempt to assemble the product.
- \* Estimated Assembly Time: 10 minutes.
- \* Tools Required for Assembly (included): Spanner
- \* If you are having difficulty, our friendly Customer Care team is always here to help.

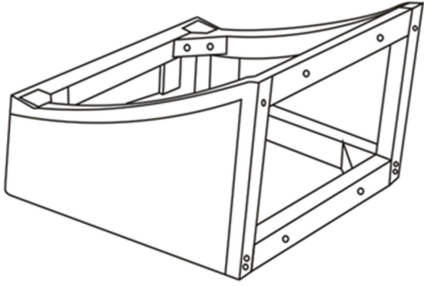
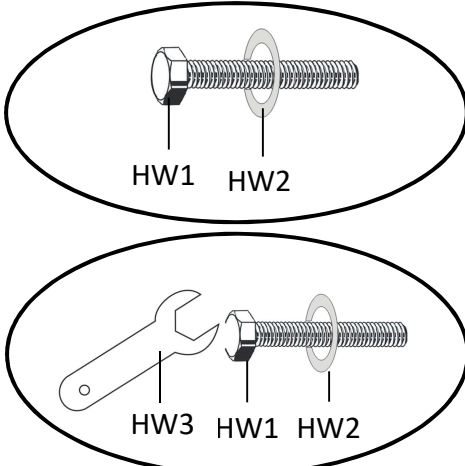
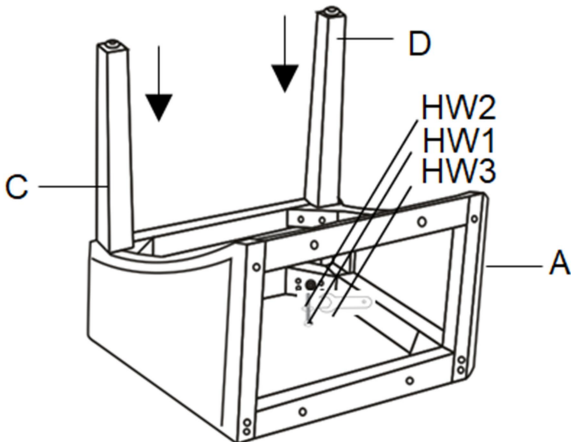
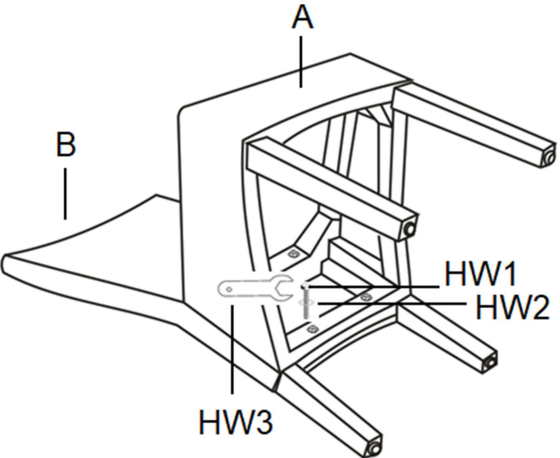
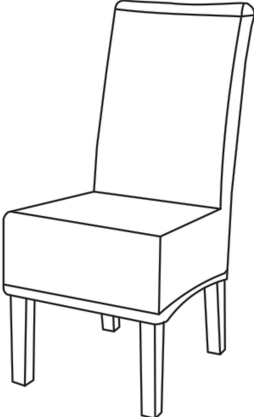
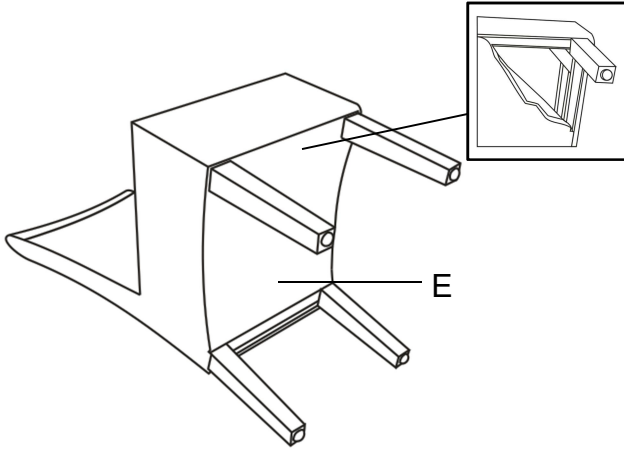
		
<p><b>STEP1</b> TAKE OUT LEGS, HARDWARE AND BLACK FABRIC WHICH PLACED ON THE UNDERSIDE OF THE SEAT</p>	<p><b>STEP2</b> PUT THE WASHERS (HW2) ON THE BOLT (HW1) IN THE ORDER SHOWN IN THE PICTURE</p>	<p><b>STEP3</b> INSERT THE FRONT LEG (C, D) IN THE BOLTS BUT DON'T TIGHTEN COMPLETELY.</p>
		
<p><b>STEP4</b> INSERT THE BACK LEGS (B) AND SCREW IN THE BOLTS BUT DON'T TIGHTEN COMPLETELY</p>	<p><b>STEP5</b> PUT THE CHAIR UPRIGHT AND MAKE SURE ALL LEGS ARE LEVEL, THEN FIRMLY TIGHTEN BOLTS WITH SPANNER (HW3) WHILE THE CHAIR IS UPRIGHT AS PICTURE ABOVE</p>	<p><b>STEP6</b> FIX THE BLACK FABRIC (E) TO THE APPROPRIATE VELCRO ON THE UNDERSIDE OF THE SEAT. BOLTS WILL REQUIRE PERIODIC TIGHTENING</p>