

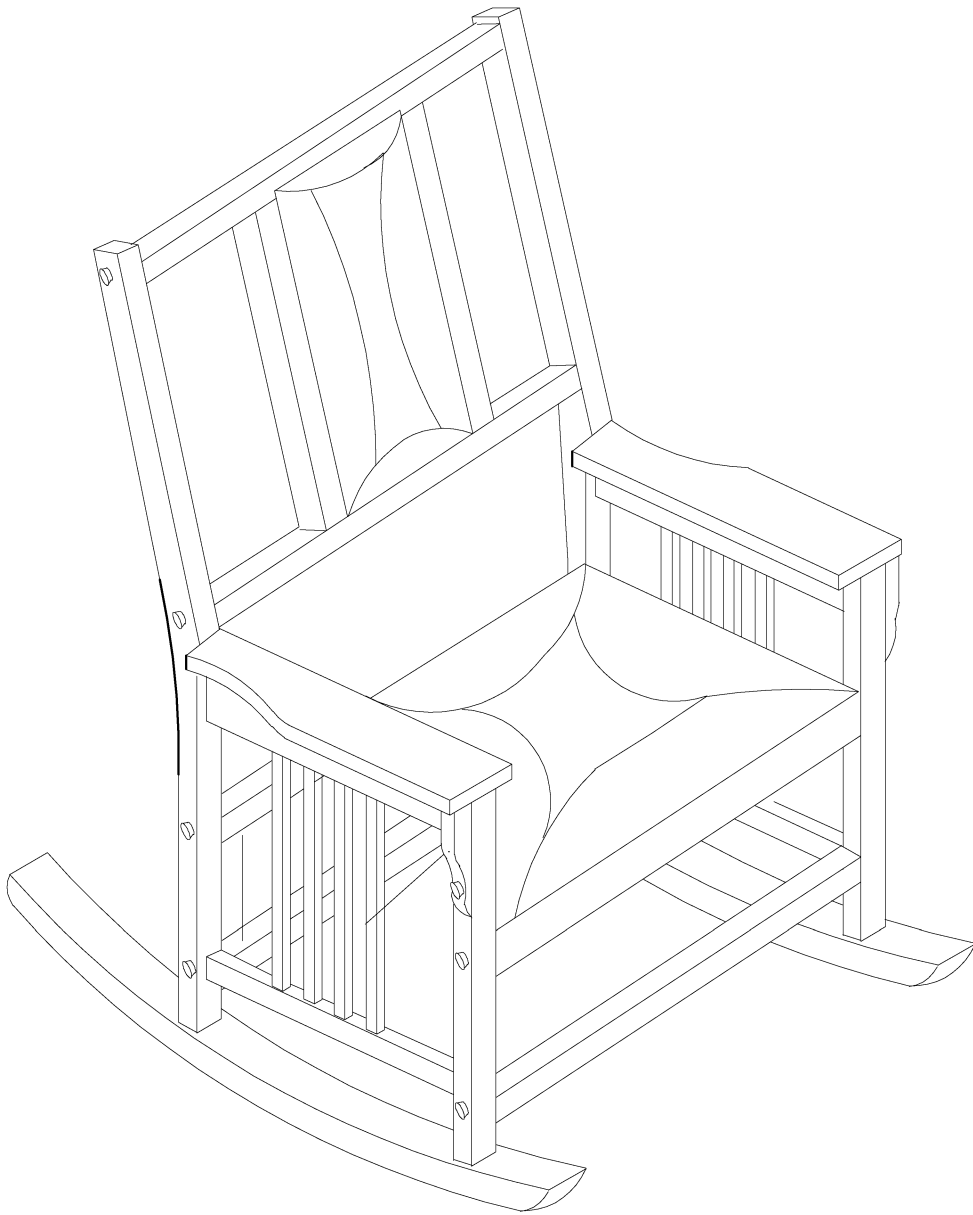











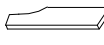

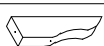
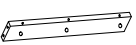
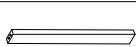
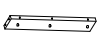

ASSEMBLY INSTRUCTION



Do not tighten screws until completely assembled.

PARTS IDENTIFICATION			
NO	Part	Sketch	Quantity
1		LEFT SIDE PANEL	1PC
2		RIGHT SIDE PANEL	1PC
3		BACK CUSHION	1PC
4		LEFT ARM	1PC
5		RIGHT ARM	1PC
6		ROCKER	2PCS
7		SEAT CUSHION	1PC
8		EAR	2PCS
9		FRONT STRETCHER TOP	1PC
10		FRONT STRETCHER BOTTOM	1PC
11		REAR STRETCHER TOP	1PC
12		REAR STRETCHER BOTTOM	1PC

HARDWARE LIST			
NO	Shape	Specification	Quantity
A		Bolt	22PCS
B		Bolt	2PCS
C		Lock Washer	20PCS
D		Flat Washer	4PCS
E		Wooden Cap	14PCS
F		Glue	1PC
G		Allen Wrench	1PC
H		Screw	4PCS

STEP 1

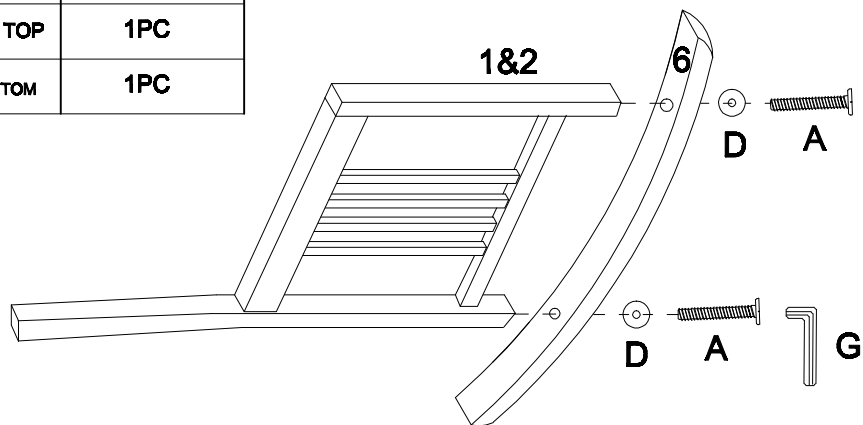

STEP 2

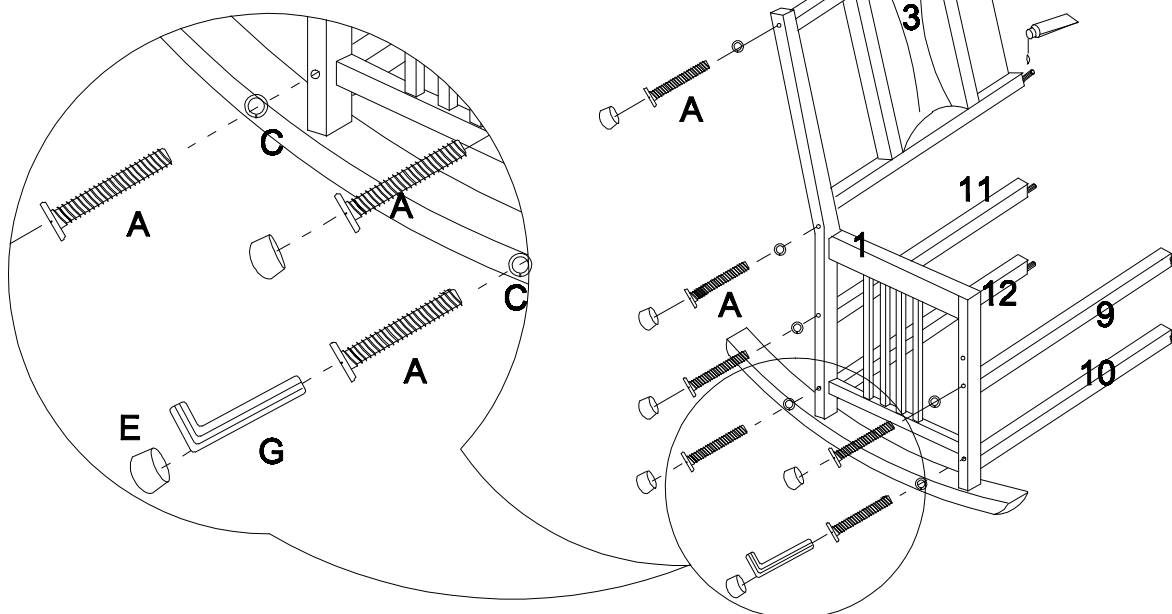

Do not tighten screws until completely assembled.

STEP 3

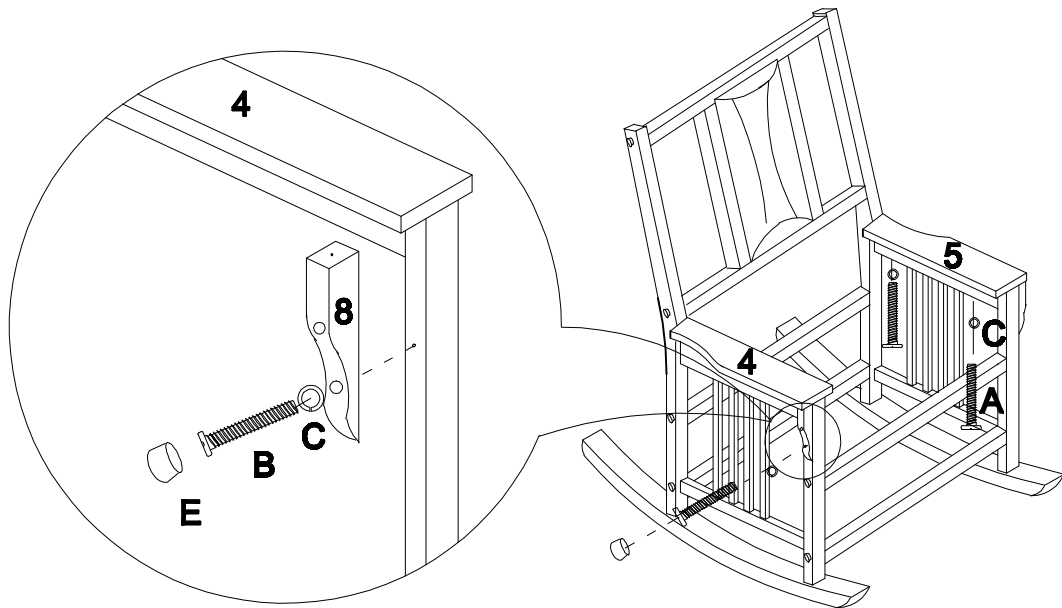

STEP 4

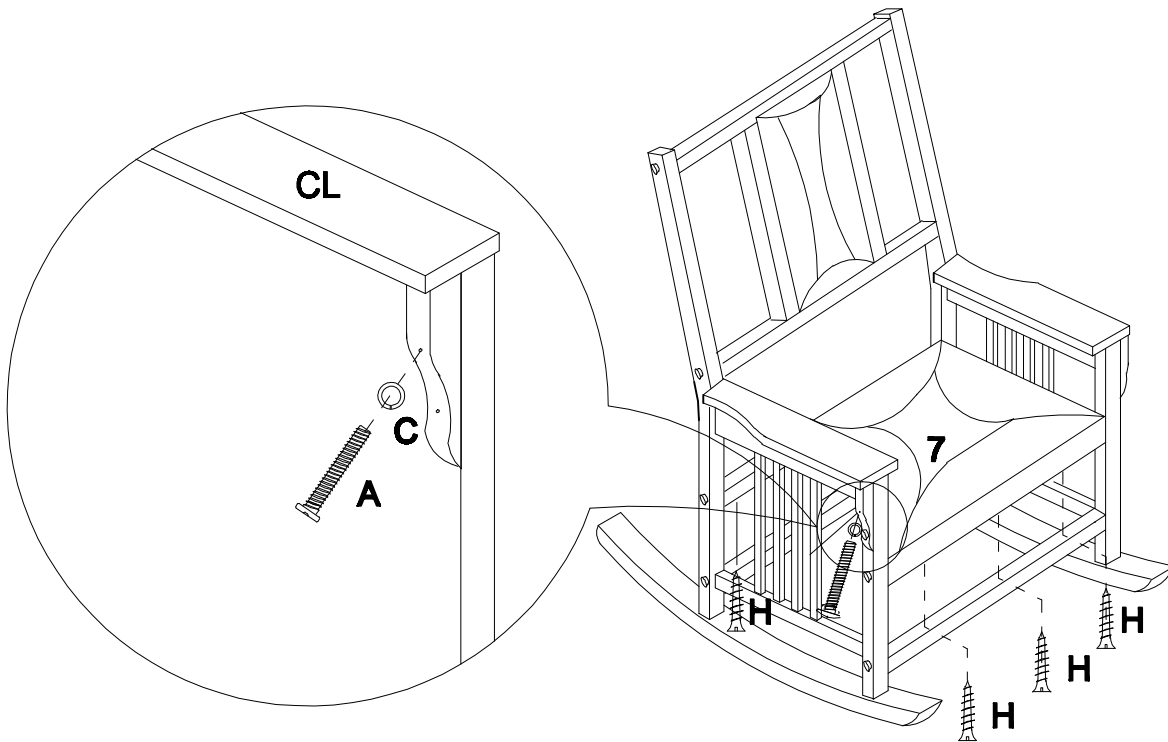

Do not tighten screws until completely assembled.