



Read this instruction carefully. See hardware and furniture part list for guidance. Be sure all parts are complete, before you assemble. Place all wooden furniture parts on a clean and flat soft surface to prevent from being scratched. Follow the figure to start assembling.

CAUTIONS : 1. Do not FULLY - TIGHTEN the nut or nut bolt until all nut or bolt is ready assembled.
2. Do not OVER - TIGHTEN the nut or bolt to avoid causing damages to the thread.
3. Keep all hardware parts out of reach of children.

NOTE : THE LIST AND QUANTITY SHOWN ARE FOR 1 UNIT ASSEMBLY.
Tool needed : Screwdriver (not provider).

PART LIST			
ITEM	DESCRIPTION	BOX	QTY
A	HEADBOARD	1	1 PC
B	FOOTBOARD	2	1 PC
C	SIDE RAIL	2	2 PCS
D	SUPPORT WOOD	2	6 PCS
E	CENTER RAIL	2	1 PC
F	CENTER SUPPORT	2	2 PCS
G	CENTER SUPPORT LEG	2	3 PCS
H	BED LEG	2	4 PCS
I	BED SLAT	2	26 PCS

HARDWARE LIST (BOX : 2)		
ITEM	DESCRIPTION	QTY
1	JCBC BOLT M6 x 20mm 	6 PCS
2	JCBC BOLT M6 x 35mm 	14 PCS
3	M6 FLAT WASHER 	8 PCS
4	M6 SPRING WASHER 	8 PCS
5	WOOD SCREW M4 x 20mm 	2 PCS
6	WOOD SCREW M3.5 X 16mm 	8 PCS
7	BED SLAT SIDE FITTER 	26 PCS
8	BED SLAT CENTER FITTER 	13 PCS
9	M4 ALLEN KEY (BALL SHAPE) 	1 PC
10	M5 ALLEN KEY (BALL SHAPE) 	1 PC

STEP 1

STEP 1.1

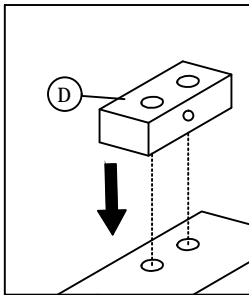

STEP 1.2

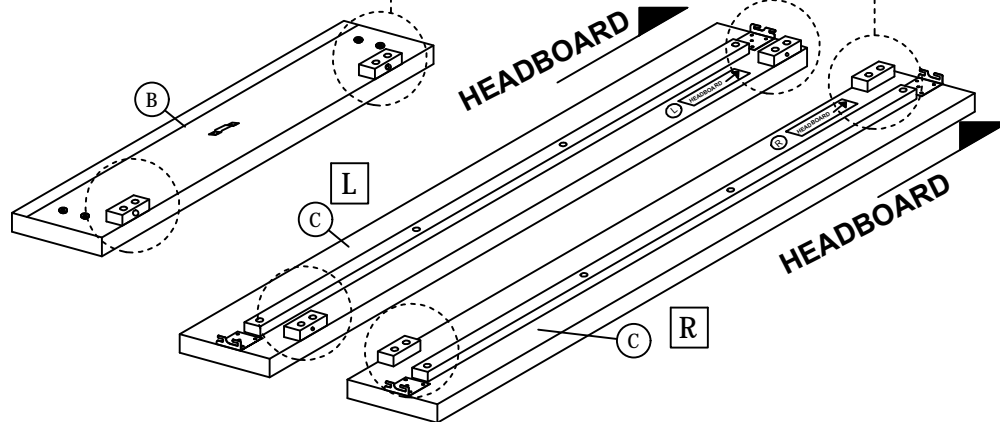
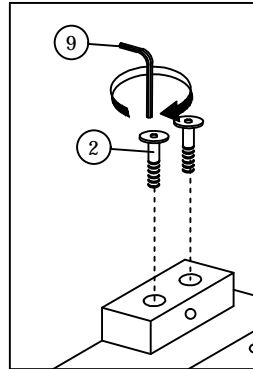

STEP 2

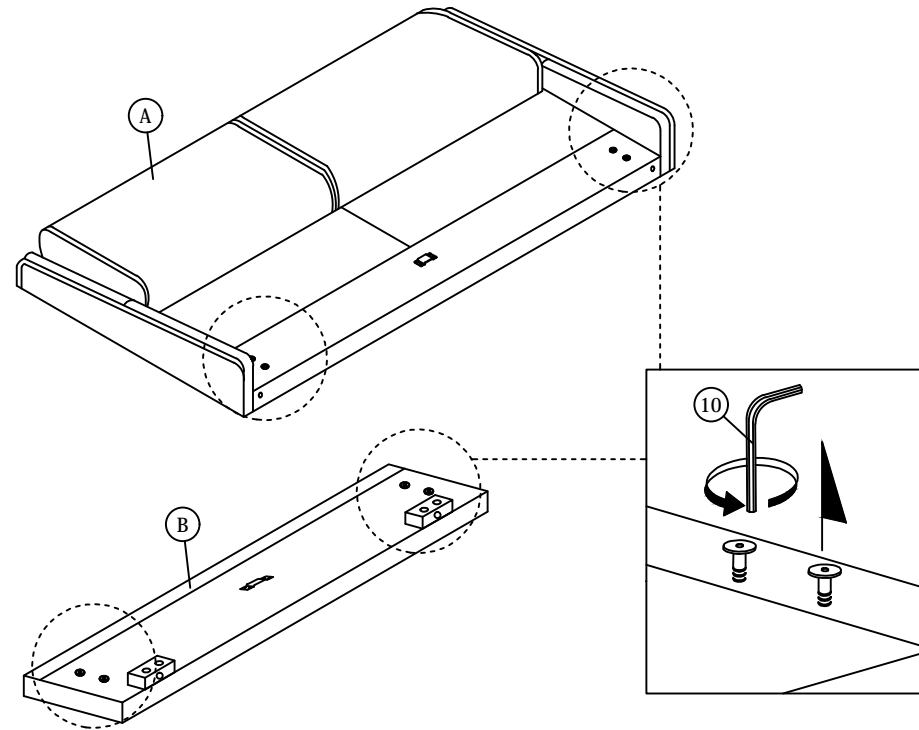

Loosen the pre-inserted bolt on the headboard and footboard using Allen key ball shape (10).

ASSEMBLY INSTRUCTIONS

STEP 3

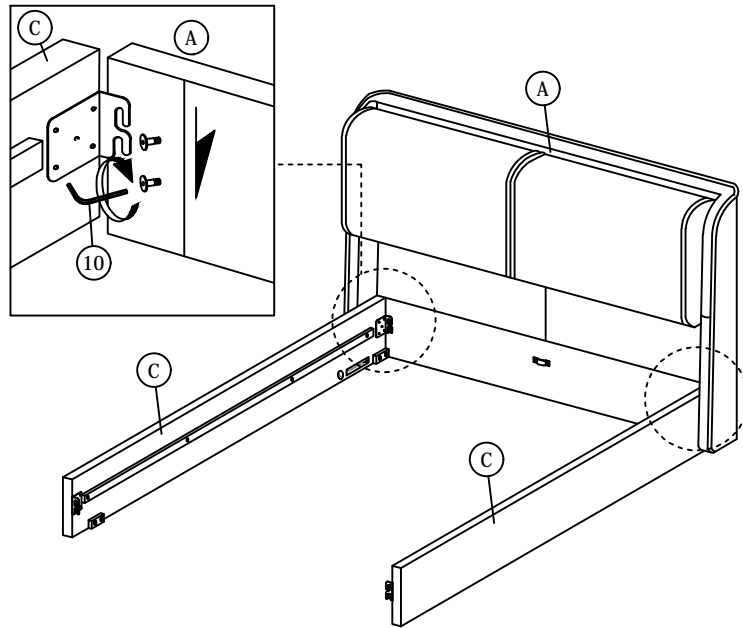

STEP 4

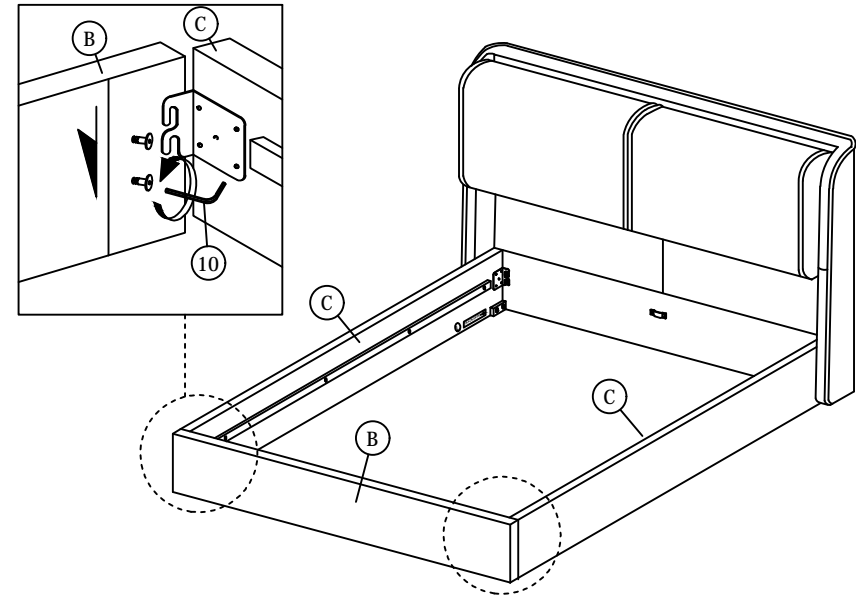

STEP 5

STEP 5.1

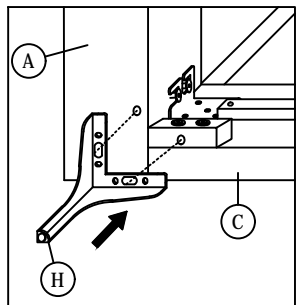

NOTE :
Make sure the floor is clean and smooth when put down the bed to prevent scratches.

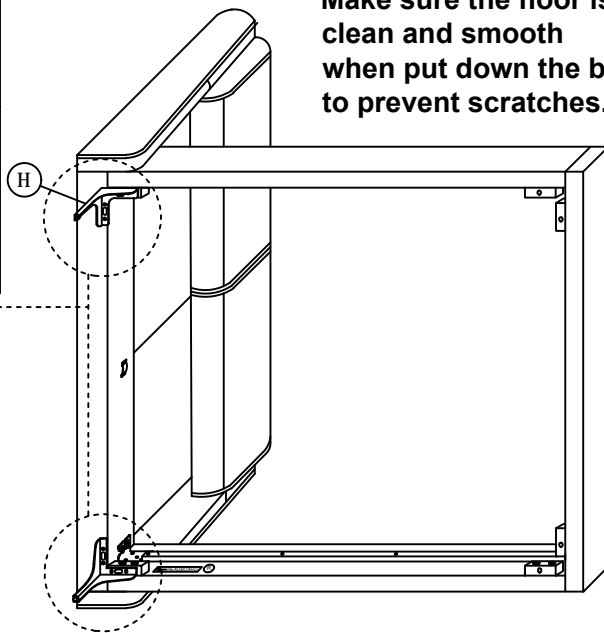

STEP 5.2

STEP 6

NOTE :
Make sure the floor is clean and smooth when put down the bed to prevent scratches.

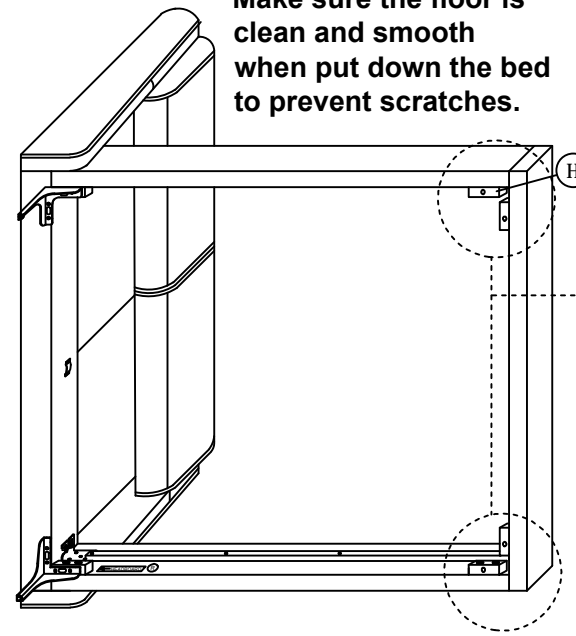

STEP 6.1

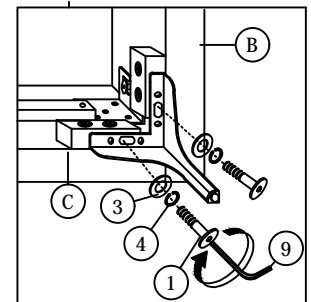
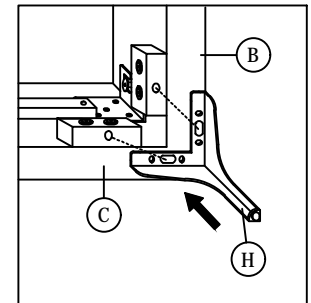

STEP 6.2

ASSEMBLY INSTRUCTIONS

STEP 7

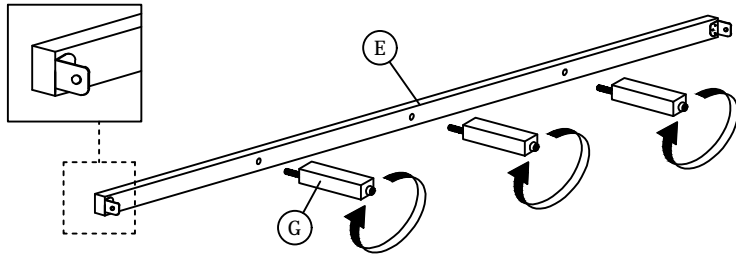

STEP 8

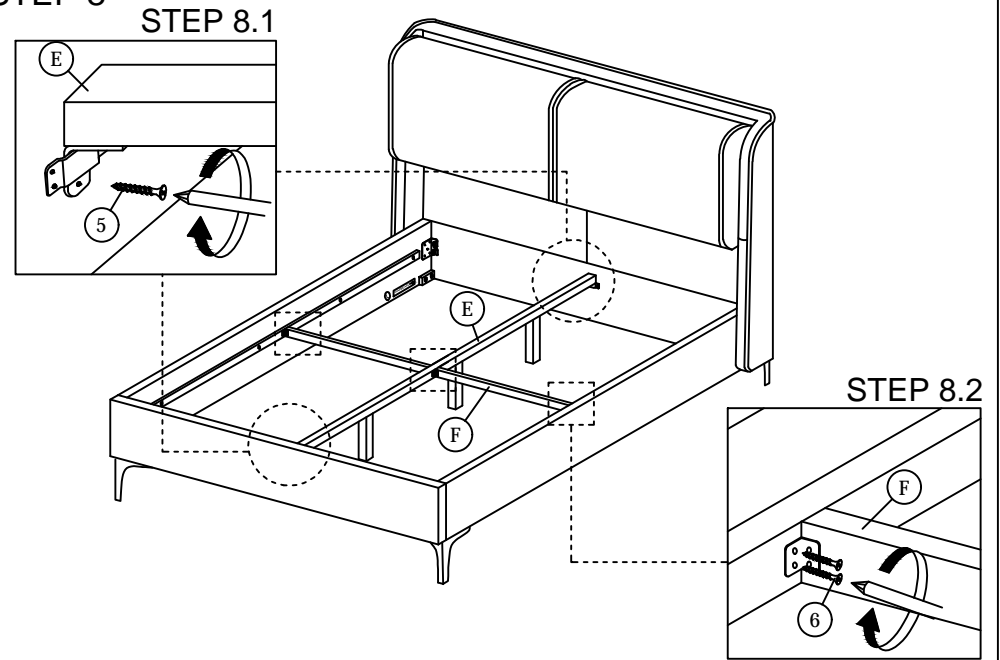

STEP 9

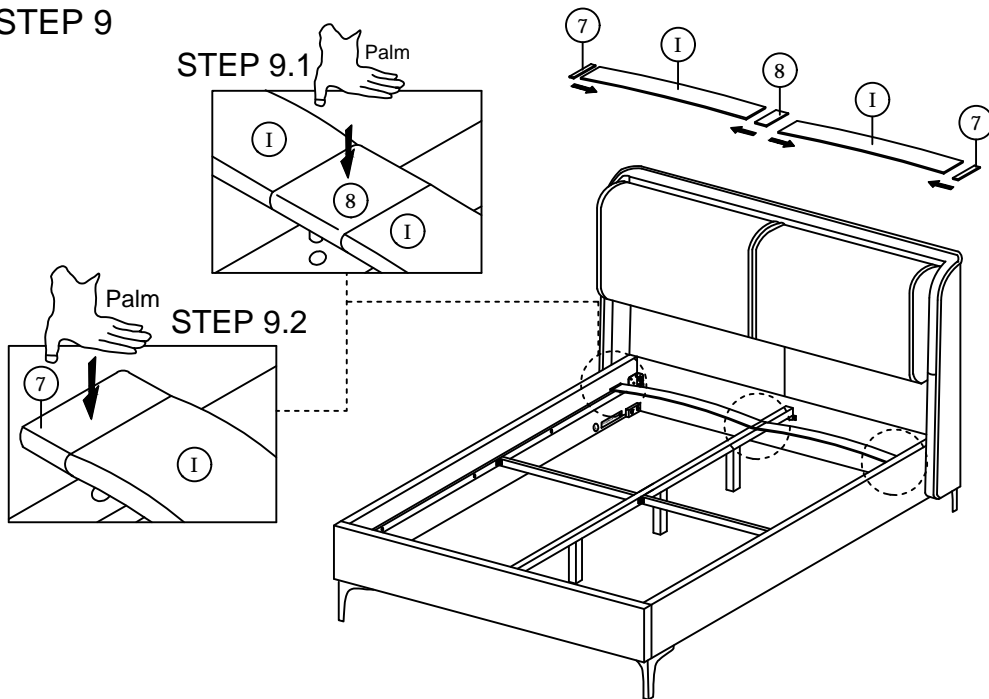

STEP 10

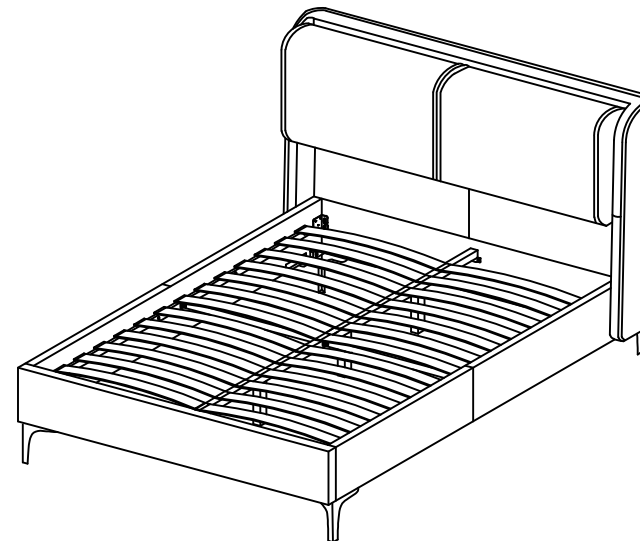

* When moving the bed position, the center support legs must be adjust to be straight to avoid any broken problem.