

# SOFA TABLE

---

## ASSEMBLY INSTRUCTION



# Assembly Instruction

## ASSEMBLY TIPS:

- 1.Remove hardware from box and sort by size.
- 2.Please check to see that all hardware and parts are present prior to start of assembly.
- 3.please follow attached instructions in the same sequence as numbered to assure fast & easy assembly.

## ⚠ Warning!

- 1.Don't attempt to repair or modify parts that are broken or defective.Please contact the store immediately.
- 2.This product is for home use only and not intended for commercial establishment.

## PARTS IDENTIFICATION:

(A) TOP

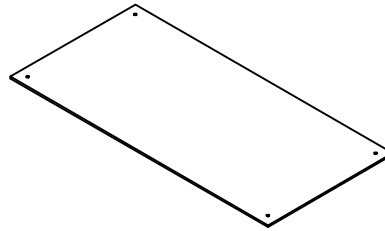

1PC

(B) TOP PILLAR

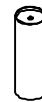

4PCS

(C) SHELF PILLAR

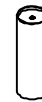

4PCS

(D) LEG

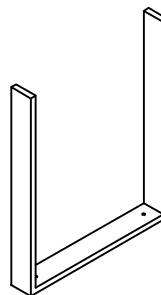





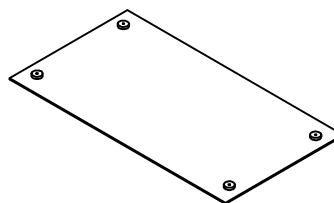



2PCS

(E) SHELF







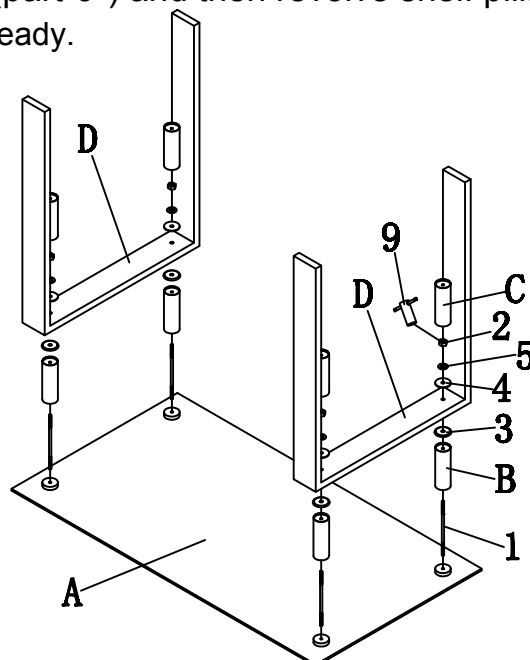

1PC





Z	HARDWARE PACKAGE:		
NO	DESCRIPTION	FIGURE	QTY
1	SCREW ROD $\Phi 5/16 \times 160\text{mm}$		4pcs
2	SCREW NUT $\Phi 5/16 \times 8\text{mm}$		4pcs
3	CHROMED WASHER $\Phi 5/16 \times 55\text{mm}$		8pcs
4	BIG WASHER $\Phi 5/16 \times 50\text{mm}$ Pla		4pcs
5	FLAT WASHER $\Phi 5/16 \times 20\text{mm}$		8pcs
6	ALLEN BOLT $\Phi 5/16 \times 35\text{mm}$		4pcs
7	SMALL WASHER $\Phi 5/16 \times 25\text{mm}$		4pcs
8	ALLEN WRENCH $\Phi 5/16 \times 66\text{mm}$		1pc
9	SPANNER $\Phi 13 \times 80\text{mm}$		1pc

STEP 1 : Place top upside down on a soft and scratch resitant surface, then spin screw rods(part"1") into 4 holes of top. Then insert top pillars (part"B") and chromed washers (part"3"), with grooved sides towards pillars, through four rods. After putting two legs (part"D"), big washers(part"4") and flat washers(part"5") through the rods,tight screw nuts (part"2") with spanner(part"9") and then revolve shelf pillars (part"C") in the rods to steady.



1		4PCS
2		4PCS
3		4PCS
4		4PCS
5		4PCS
9		

**STEP 2:** Put chromed washers on pillars ( part"B")with grooved side down, and then align the holes of shelf (part"E") to that of chromed washers(part"3").Then put small washers(part"7"),flat washer(part"5"),and screw Allen bolts(part"6")into the holes tightly with Allen wrench.

3		4PCS
5		4PCS
6		4PCS
7		4PCS
8		

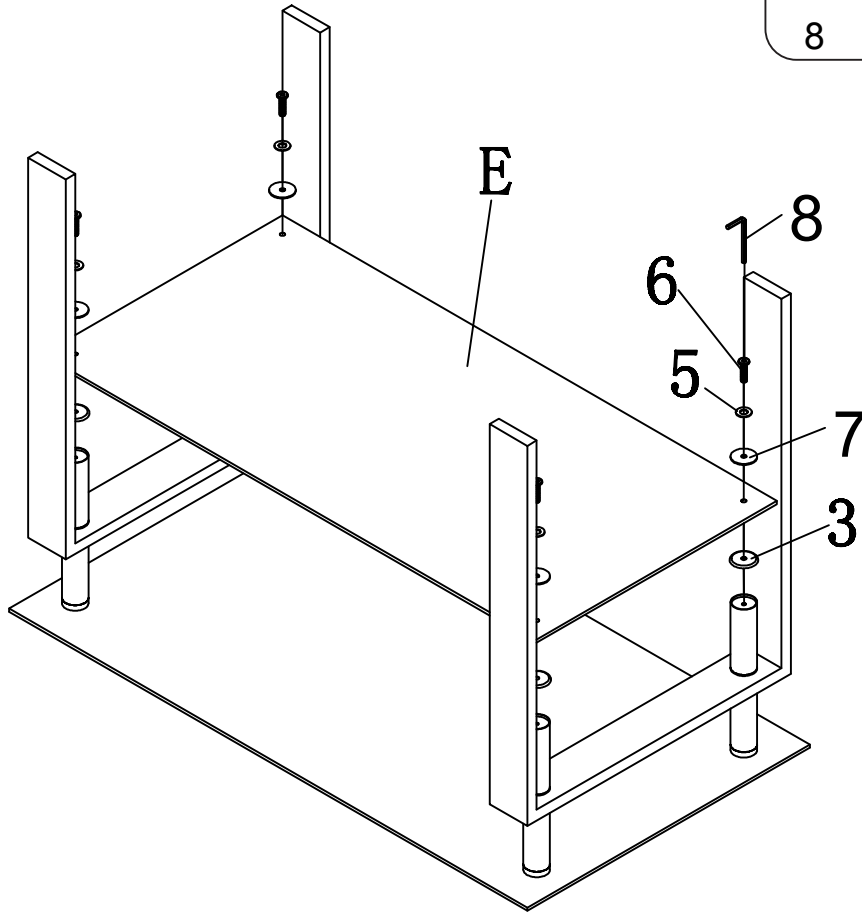

**STEP 3:** Complete.

