

Insrallation Instruction

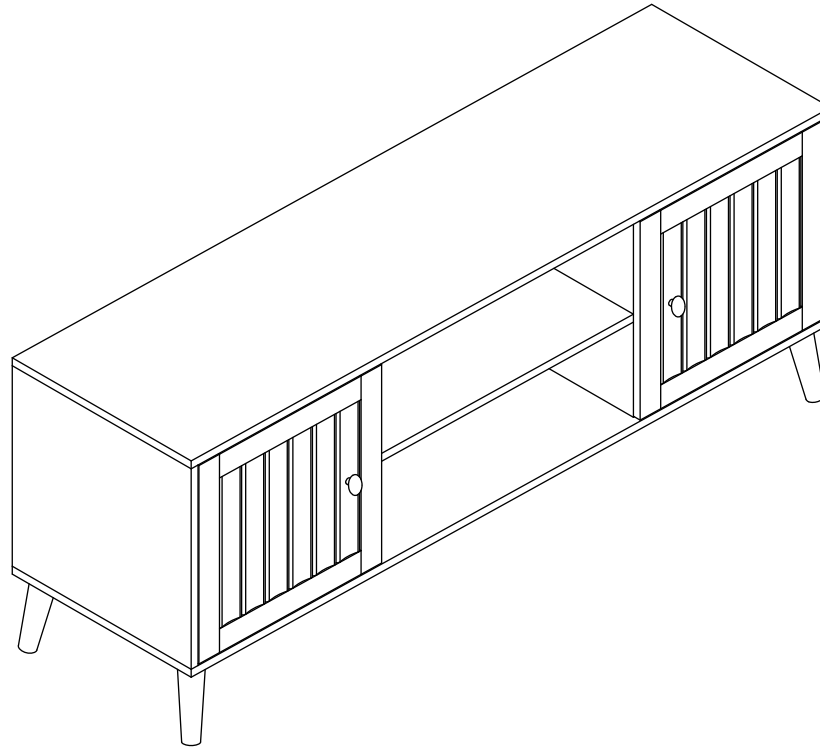

EN

1. Place all parts on a clean, flat, and soft surface (e.g., carpet or rug) to prevent scratches.
2. DO NOT USE POWER TOOLS FOR ASSEMBLY.
3. Do not sit, stand, or allow children to climb, sit, or stand on the assembled product.
4. KEEP ALL HARDWARE PARTS OUT OF CHILDREN'S REACH.
5. DISPOSE OF PLASTIC PACKAGING IMMEDIATELY TO PREVENT SUFFOCATION RISKS TO CHILDREN OR PETS.
6. For safety reasons, this unit must be securely mounted to the wall.
7. Assembly requires two people.

DE

1. Legen Sie alle Teile auf eine saubere, flache und weiche Oberfläche (z. B. Teppich oder Matte), um Kratzer zu vermeiden.
2. VERWENDEN SIE KEINE ELEKTROWERKZEUGE FÜR DEN ZUSAMMENBAU.
3. Setzen oder stellen Sie sich nicht auf das montierte Produkt, und lassen Sie Kinder nicht darauf klettern, sitzen oder stehen.
4. HALTE ALLE HARDWARETEILE AUSSERHALB DER REICHWEITE VON KINDERN.
5. ENTSORGEN SIE KUNSTSTOFFVERPACKUNGEN SOFORT, UM ERSTICKUNGSRISIKEN FÜR KINDER ODER HAUSTIERE ZU VERMEIDEN.
6. Aus Sicherheitsgründen muss diese Einheit sicher an der Wand befestigt werden.
7. Für den Zusammenbau werden zwei Personen benötigt.

FR

1. Placez toutes les pièces sur une surface propre, plate et molle (par exemple, un tapis ou une moquette) pour éviter les rayures.
2. N'UTILISEZ PAS D'OUTILS ÉLECTRIQUES POUR LE MONTAGE.
3. Ne vous asseyez pas, ne vous tenez pas debout et ne laissez pas les enfants grimper, s'asseoir ou se tenir debout sur le produit assemblé.
4. GARDEZ TOUTES LES PIÈCES DE QUINCAILLERIE HORS DE PORTÉE DES ENFANTS.
5. ÉLIMINEZ IMMÉDIATEMENT LES EMBALLAGES PLASTIQUES POUR ÉVITER TOUT RISQUE D'ÉTOUFFEMENT POUR LES ENFANTS OU LES ANIMAUX DOMESTIQUES.
6. Pour des raisons de sécurité, cette unité doit être solidement fixée au mur.
7. Le montage nécessite deux personnes.

ES

1. Coloque todas las partes sobre una superficie limpia, plana y suave (por ejemplo, alfombra o tapete) para evitar rayaduras.
2. NO UTILICE HERRAMIENTAS ELÉCTRICAS PARA EL ENSAMBLAJE.
3. No se siente, no se pare ni permita que los niños se suban, se sienten o se paren sobre el producto ensamblado.
4. MANTENGA TODAS LAS PIEZAS DE HERRAMIENTA FUERA DEL ALCANCE DE LOS NIÑOS.
5. DESECHE INMEDIATAMENTE LOS ENVASES DE PLÁSTICO PARA EVITAR CUALQUIER RIESGO DE ASFIXIA PARA NIÑOS O MASCOTAS.
6. Por razones de seguridad, es imprescindible que esta unidad esté fijada a la pared.
7. Se necesitan dos personas para el ensamblaje.

Technical Support : service0530@163.com



MADE IN CHINA

IT

1. Posizionare tutte le parti su una superficie pulita, piana e morbida (ad esempio, tappeto o moquette) per evitare graffi.
2. NON UTILIZZARE UTENSILI ELETTRICI PER IL MONTAGGIO.
3. Non sedersi, non stare in piedi e non permettere ai bambini di arrampicarsi, sedersi o stare in piedi sul prodotto assemblato.
4. TENERE TUTTE LE PARTI DI FERRAMENTA FUORI DALLA PORTATA DEI BAMBINI.
5. SMALTIRE IMMEDIATAMENTE GLI IMBALLAGGI DI PLASTICA PER EVITARE QUALSIASI RISCHIO DI SOFFOCAMENTO PER BAMBINI O ANIMALI DOMESTICI.
6. Per motivi di sicurezza, è imperativo che questa unità sia fissata al muro.
7. Per il montaggio sono necessarie due persone.

WARNING!!

Children have died from furniture tipover. Tip restraints have been included with this product; you must install the tip restraints according to these instructions in order to minimize the risk of furniture tipping.

- In addition to installing the restrains , to help prevent tip-over**
1. **NEVER** put a TV or other heavy objects on top of this product".
 2. **Do not stand on the product.**

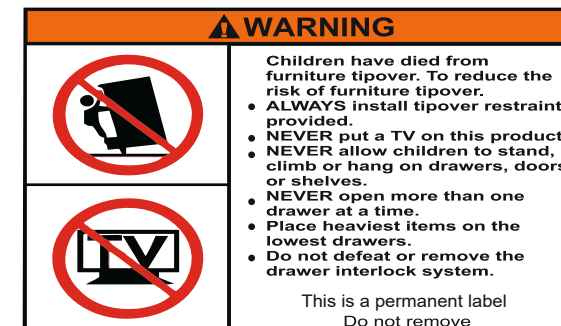

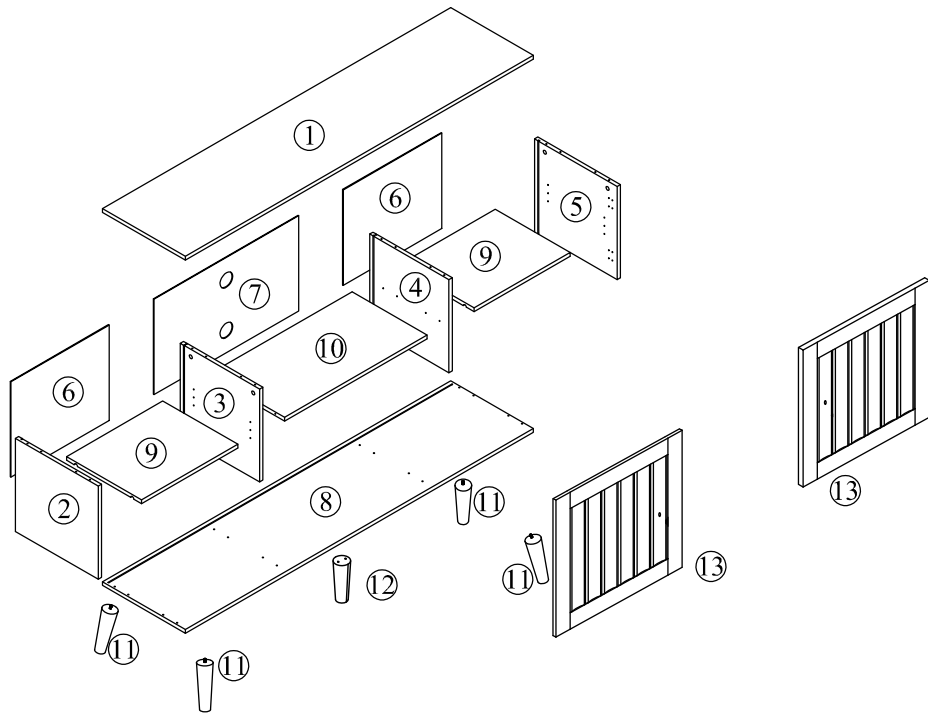

	A	8+1pcs		H	4pcs
	B	8+1pcs		I	8pcs
M6x30mm	C	21+1pcs	M4x35mm	J	2pcs
M4x35mm	D	12+1pcs		K	4pcs
	E	1pc		L	2pcs
	F	1pc		M	4pcs
M4x12mm	G	50+2pcs			

STEP 1

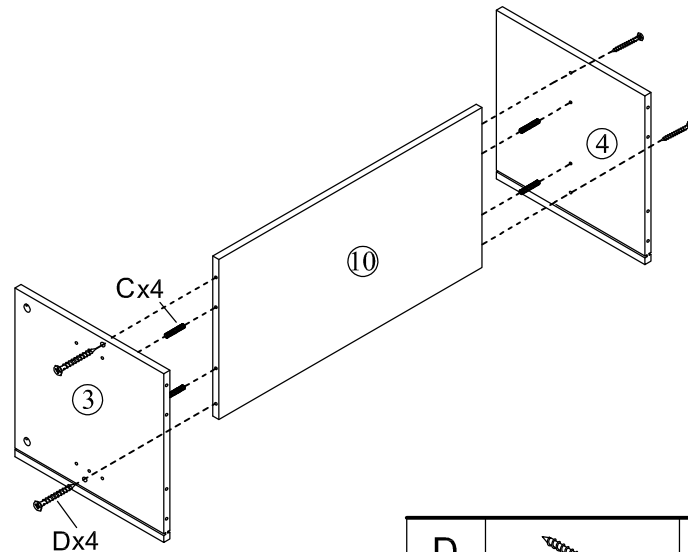

D		4pcs
C		4pcs

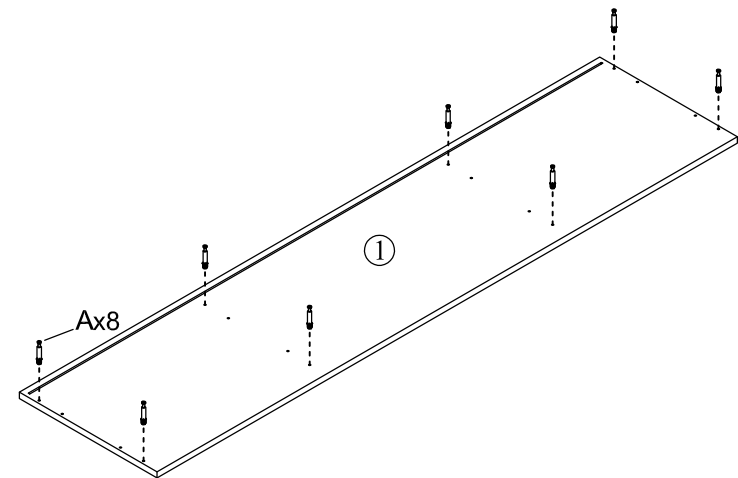

STEP 2

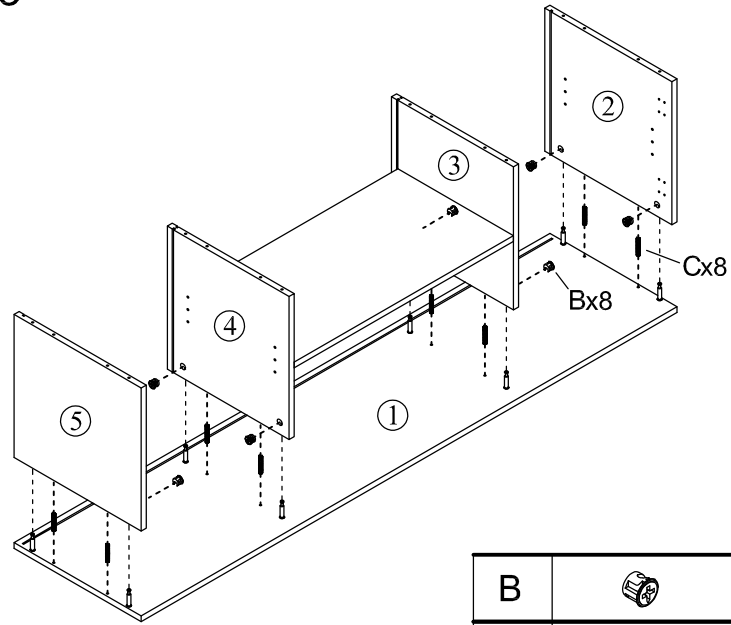

A		8pcs
---	--	------

STEP 3



B		8pcs
C		8pcs

STEP 4

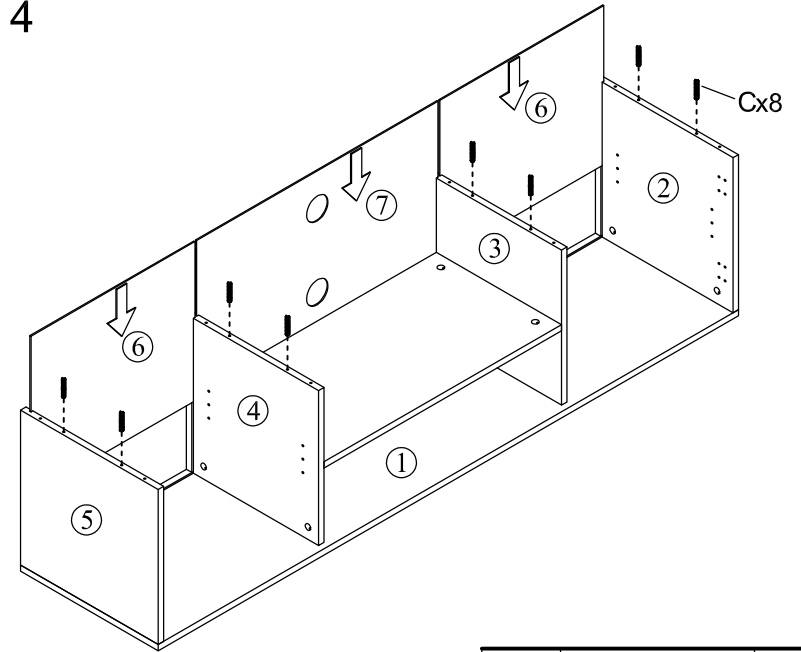

C		8pcs
---	-------------------------------------------------------------------------------------	------

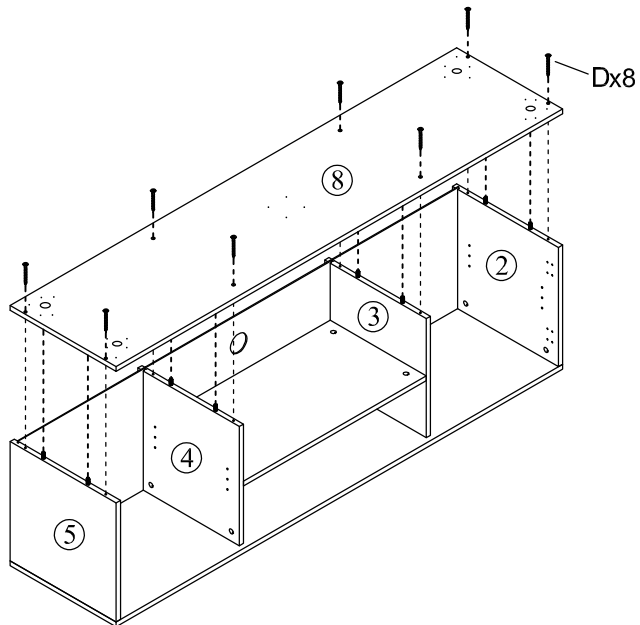

STEP 5

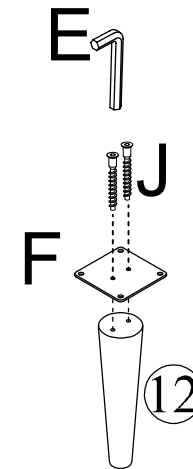

D		8pcs
---	-------------------------------------------------------------------------------------	------

STEP 6



E		1pc
F		1pc
J		2pcs

STEP 7

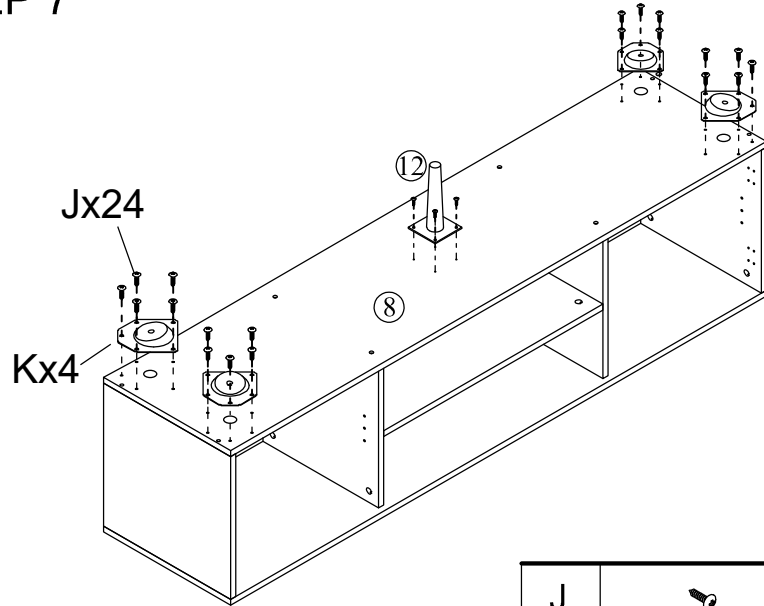

J		24pcs
K		4pcs

STEP 8

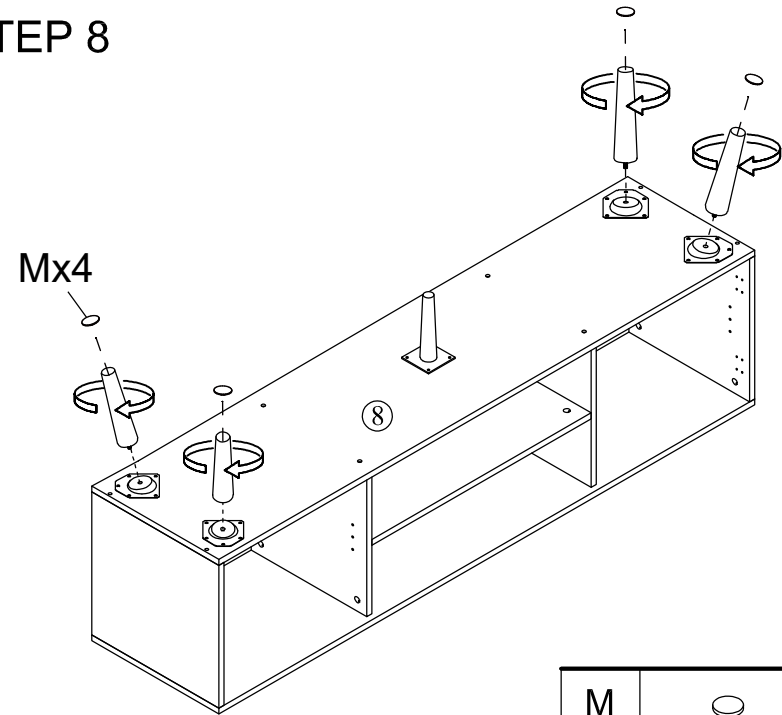

M		4pcs
---	--	------

STEP 9

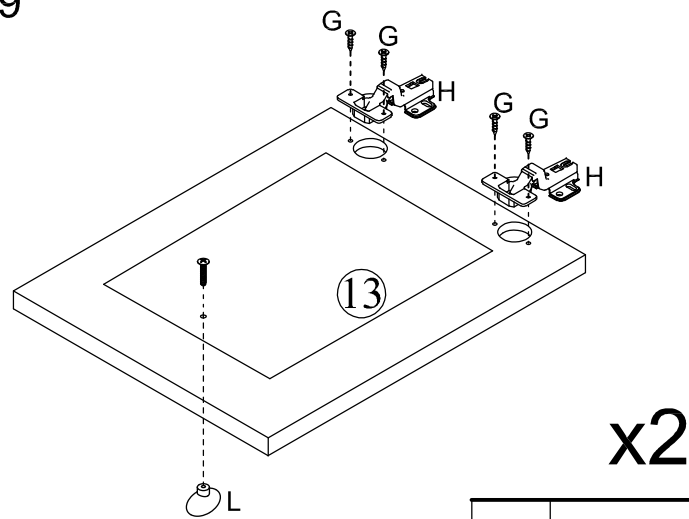

L		2pcs
G		8pcs
H		4pcs

STEP 10

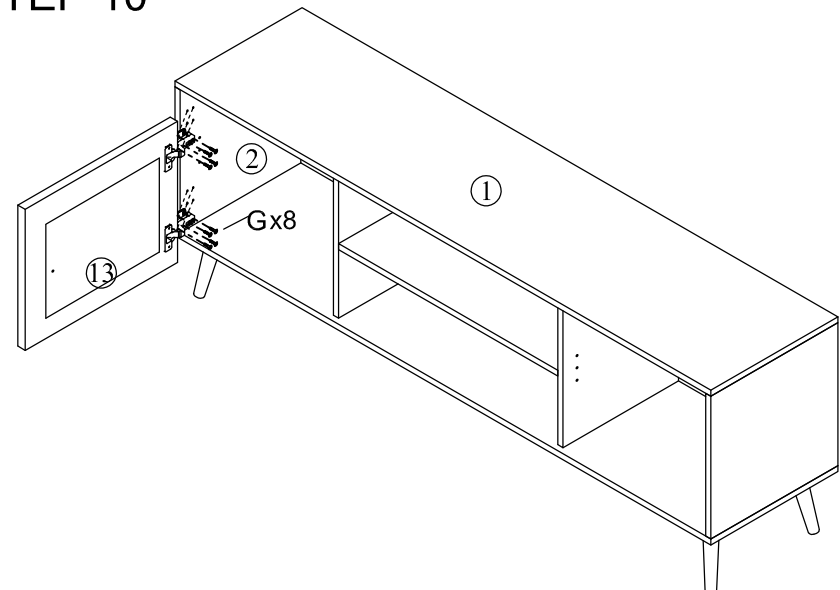

G		8pcs
---	--	------

STEP 11

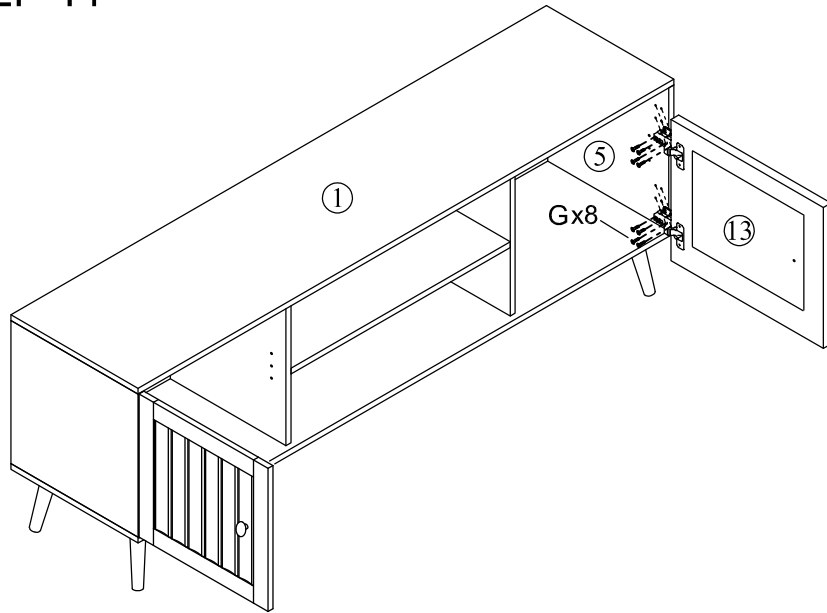

G		8pcs
---	-----------------------------------------------------------------------------------	------

STEP 12

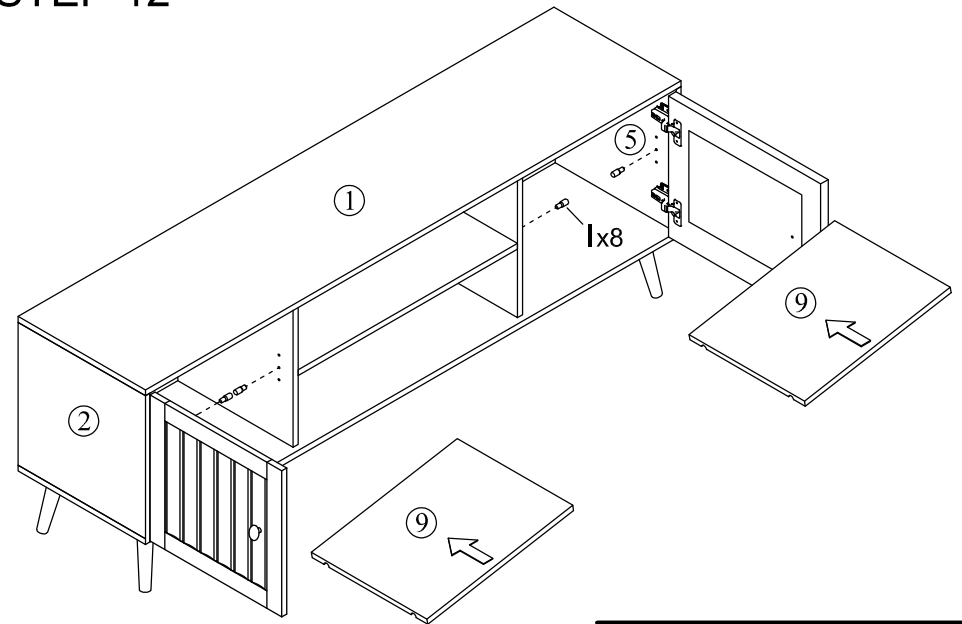

I		8pcs
---	-------------------------------------------------------------------------------------	------

STEP 13

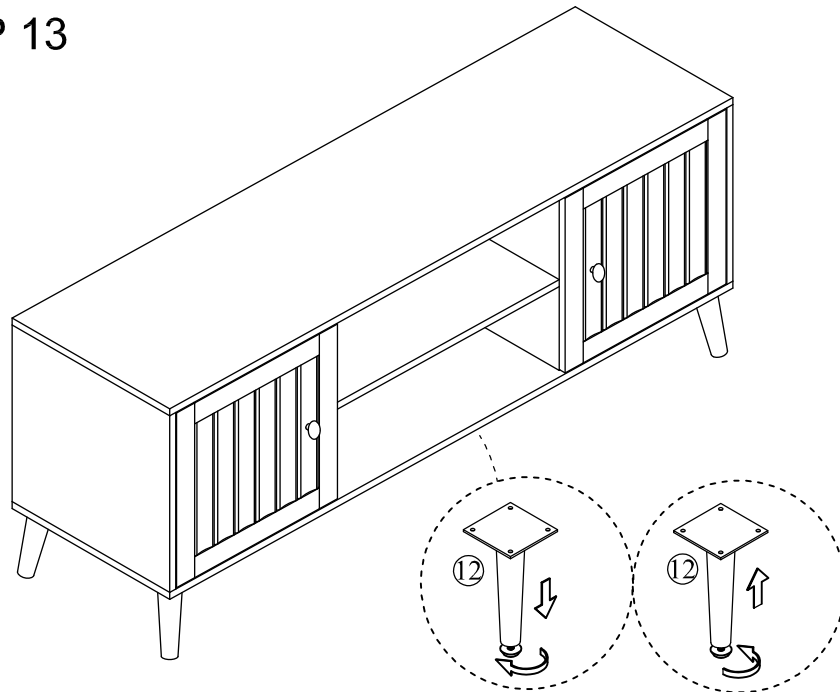

STEP 14

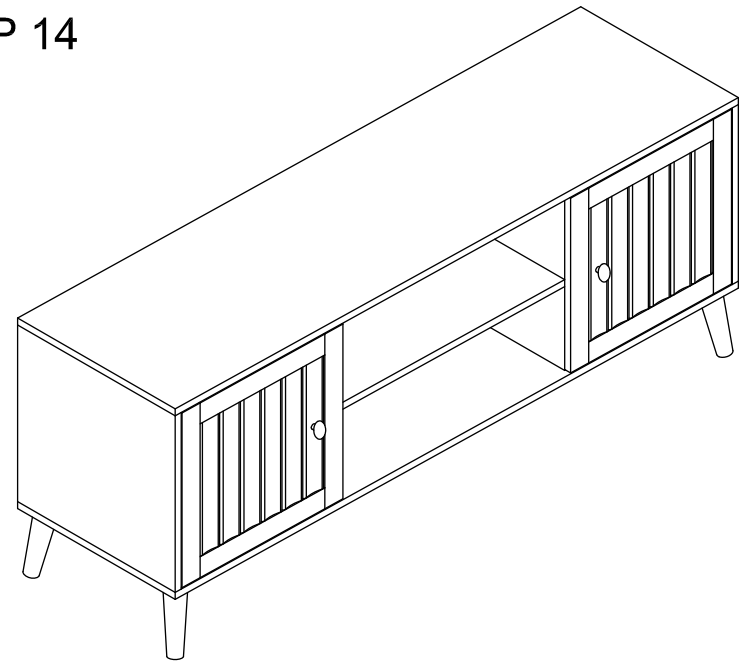

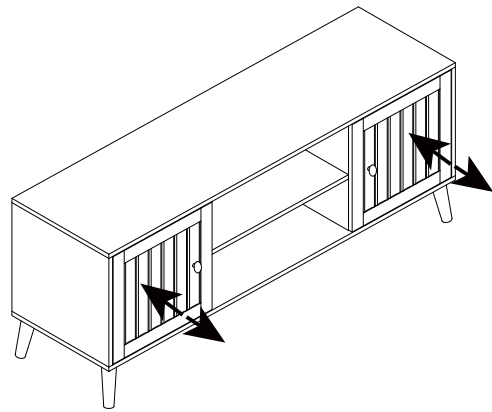

Move the door in and out

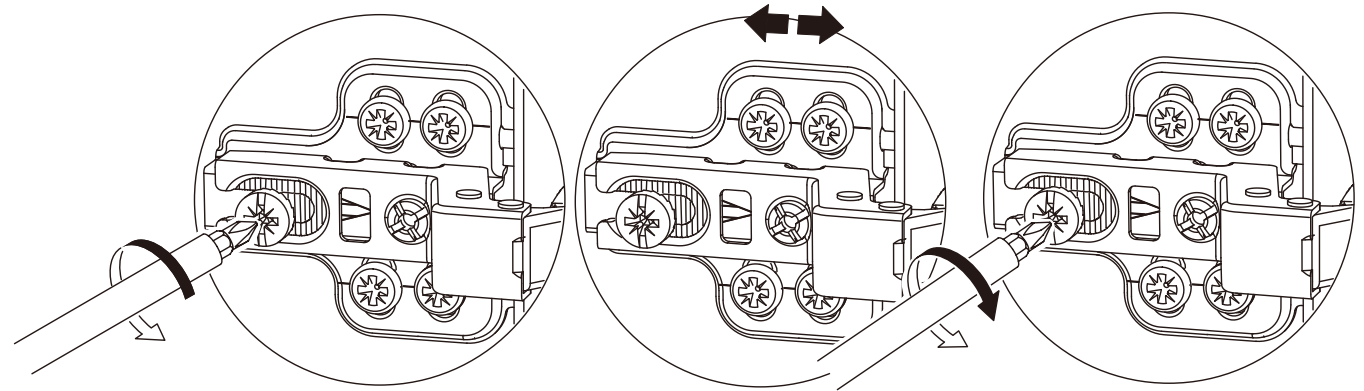

If the door doesn't meet the box at the top, adjust the top hinge toward the cabinet and/or adjust the bottom hinge away from the cabinet. If the door is gapped at the bottom, do the reverse.

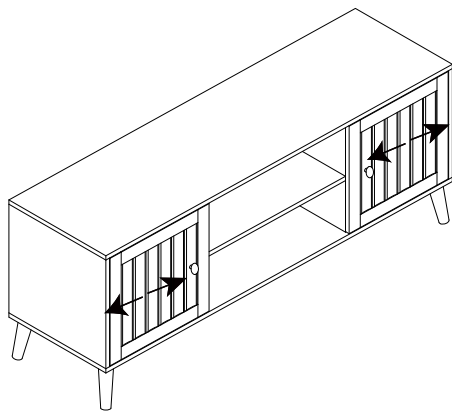

Move the door right or left

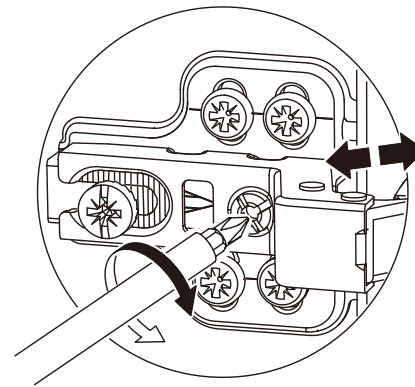

You can adjust one or both hinges on each door, depending on how much correction it needs. If the door seems to be tilting down to the right, turn the side-to-side screw on the top hinge so the hinge pulls closer to the side of the cabinet box, moving the top of the door to the left.