

TV Stand

Assembly Instruction – Please keep properly for future reference.

If you find any missing boxes, damaged parts, or accessory shortages, please contact the customer service team of your purchasing channel immediately. We will resolve the issue as quickly as possible.

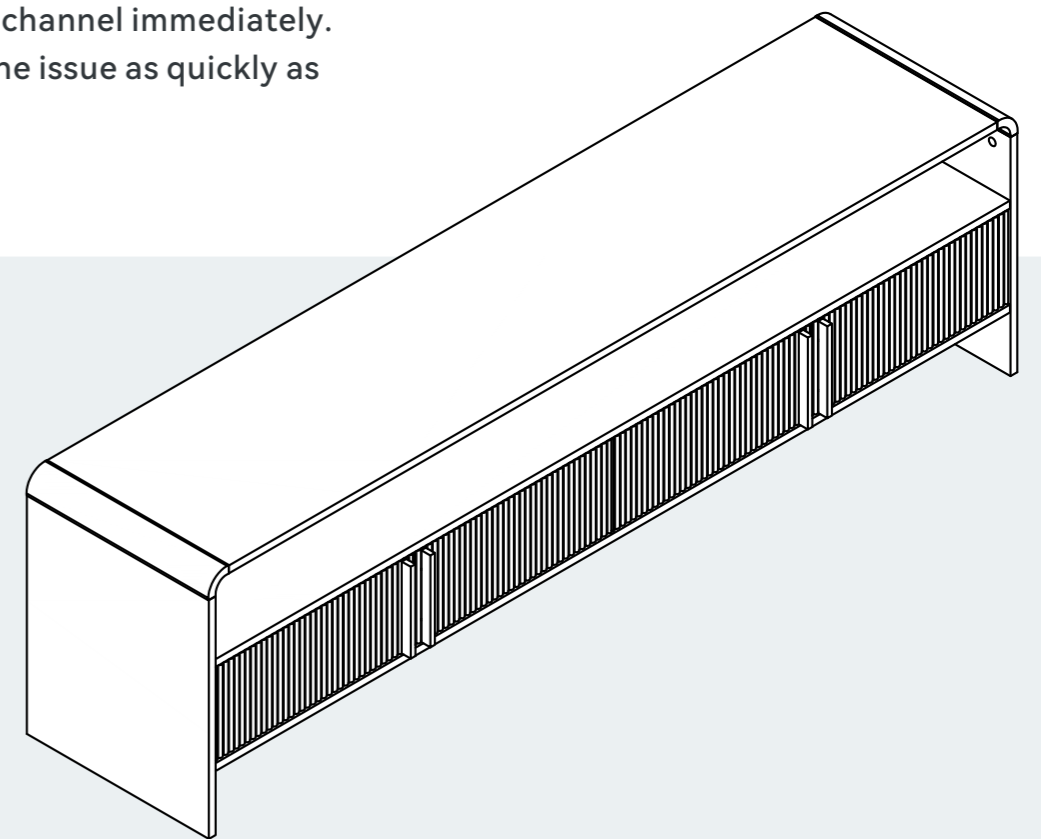

CONTACT US

- **Email:** service@grandtunnel.com
In order to receive assistance more quickly, please provide

THE FOLLOWING INFORMATION:

- Order number
- Purchase platform
- Purchase date
- Detailed description of the issue along with photos (if applicable)

Important – Please read these instructions carefully before starting the installation.

SKU:
C001505010
C001505020
C001505030

V2.0

EN

| TV Stand

Before Assembly



Thank you for choosing our product!

To ensure a smooth installation process, please read this guide carefully to familiarize yourself with the required tools, materials, and installation steps.

Follow the relevant sections to avoid any damage caused by improper installation, and make sure to review all operation and safety guidelines for correct installation procedures.

Packaging Notice:

If you find any missing boxes, damaged parts, or accessory shortages, please contact the customer service team of your purchasing channel immediately. We will resolve the issue as quickly as possible.

Safety and Care Advice



Important :

Please read these instructions fully before starting assembly.

- Check you have all the components and tools listed on the following pages.
- Remove all fittings from the plastic bags and separate them into their groups.
- Keep children and animals away from the work area, small parts could choke if swallowed.
- Make sure you have enough space to layout the parts before starting.
- During assembly do not stand or put weight on the product, this could cause damage.
- Assemble the item as close to its final position (in the same room) as possible.
- Assemble on a soft level surface to avoid damaging the unit or your floor.
- Parts of the assembly will be easier with 2 people.



- To reduce the likelihood of damaging your product please ensure that your power drill is set on a low torque setting.

Care and Maintenance

- Only clean using a damp cloth and mild detergent, do not use bleach or abrasive cleaners.
- From time to time check that there are no loose screws on this unit.
- This product should not be discarded with household waste. Take to your local authority waste disposal center.

Handy Hints

- Assemble all parts and bolts loosely during assembly, only once the product is complete should you fully tighten the bolts.
- Regularly check and ensure that all bolts and fittings are tightened properly.

Warning

In order to help prevent overturning, please follow these instructions.

- Use the anti tip strap or wall fixing method provided (if applicable).
- Do not allow children to climb or hang on the furniture.
- Do not open more than one drawer at a time.
- Do not place heavy items in the top drawers.
- Do not place heavy items on top of the furniture, unless the furniture has been designed for this purpose.
- Please note that only the anti tip strap is provided. You will need to provide wall plugs and screws applicable for your wall type.

Customer Service Guide



Thank you for choosing our product! We are committed to providing you with excellent service. If you find any missing parts, damaged packaging, or product damage after receiving all packages, please follow the steps below to quickly contact our customer service team. We will do our best to resolve your issue.

1. Missing Parts

Verify Parts:

1. Refer to the “Parts List” in the manual to verify the name, specifications, and quantity of the missing parts.
2. Take a clear photo of the parts list and mark the missing parts with detailed information, e.g., “Missing 5 pieces of M6×30mm screws.”

Contact Us:

By Email:

Send an email to service@grandtunnel.com, with the subject line “Missing Parts Issue.” Include the following in the email:

- A description of the missing parts and a photo of the parts list.
- Order details (order number, purchase platform, purchase date).

2. Product or Packaging Damage

If it affects normal use:

Steps:

1. Take clear photos or videos showing the damaged parts and the extent of the damage (multi-angle shots are recommended).
2. Email the photos/videos along with order details to service@grandtunnel.com, with the subject line “Product Damage Issue.”

Resolution:

After verification, we will arrange for a replacement part, product exchange, or refund as quickly as possible.

If it does not affect normal use:

Steps:

1. Contact our customer service team (by email: service@grandtunnel.com).
2. Provide a description of the damage and include relevant photos or videos.

Resolution:

We will provide repair guidance or an appropriate compensation plan based on the specific situation.

Contact Us:

Customer Service Email: service@grandtunnel.com

Helpful Tips

To process your issue efficiently, please prepare the following information:

- Order details (order number, purchase platform, purchase date).
- Clear photos or videos.
- We are committed to providing quick and professional solutions, no matter the size of the issue, to ensure your satisfaction.

Thank you for your trust and support!
We hope you enjoy using our product!

Parts List - Panels



Please check you have all the panels listed below.

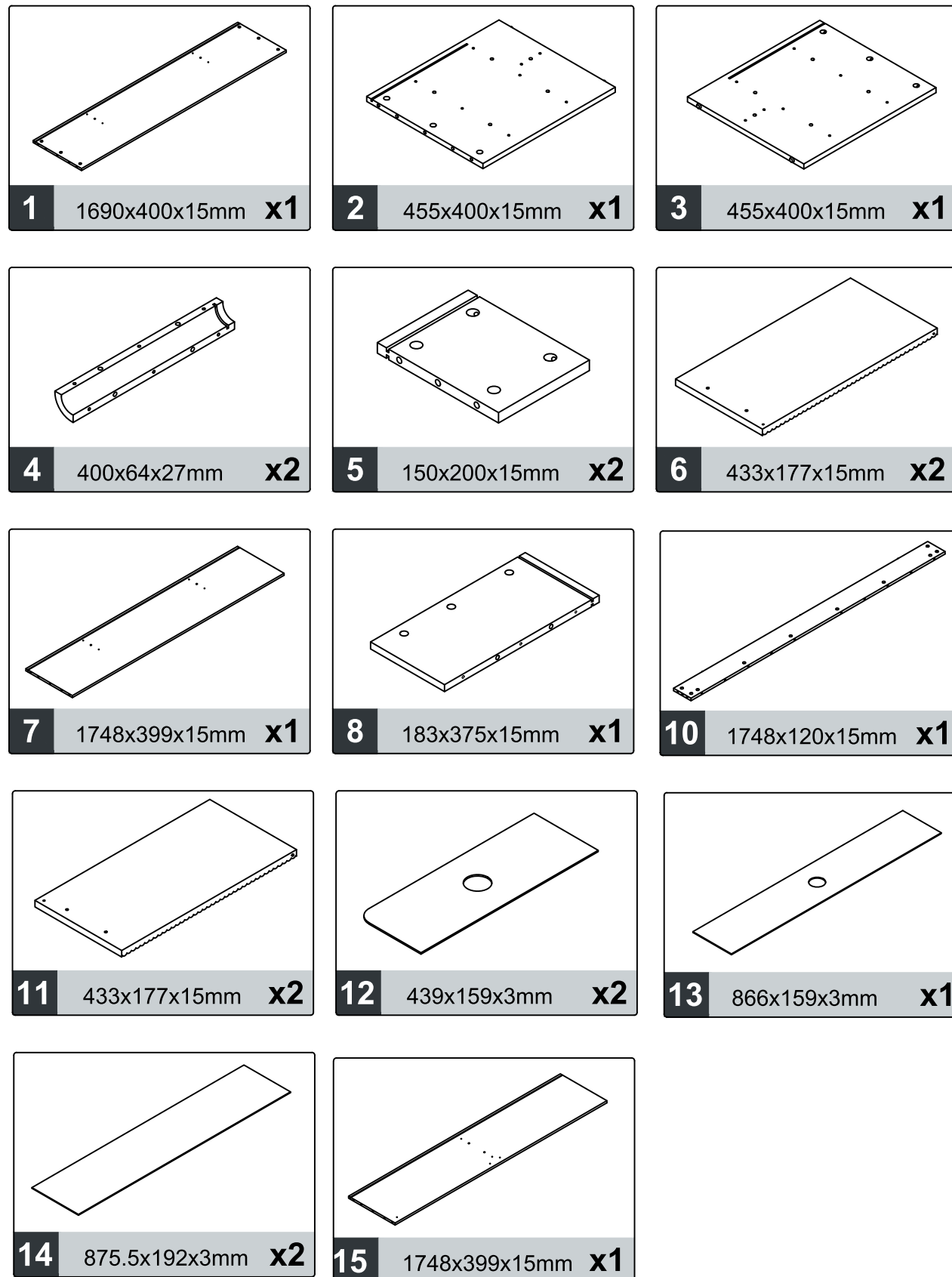

Parts List - Fittings



Please check you have all the fittings listed below.

Note: The quantities below are the correct amount to complete the assembly. In some cases more fittings may be supplied are required.



Cam Lock Fastening System

Insert the cam bolt into the hole first, then insert the cam lock and lock it.

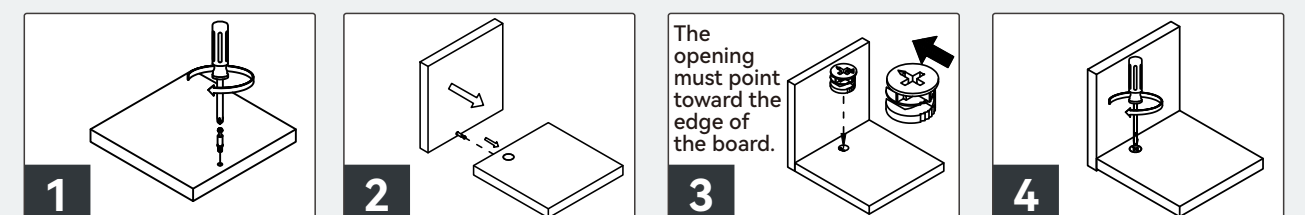

Assembly Instructions

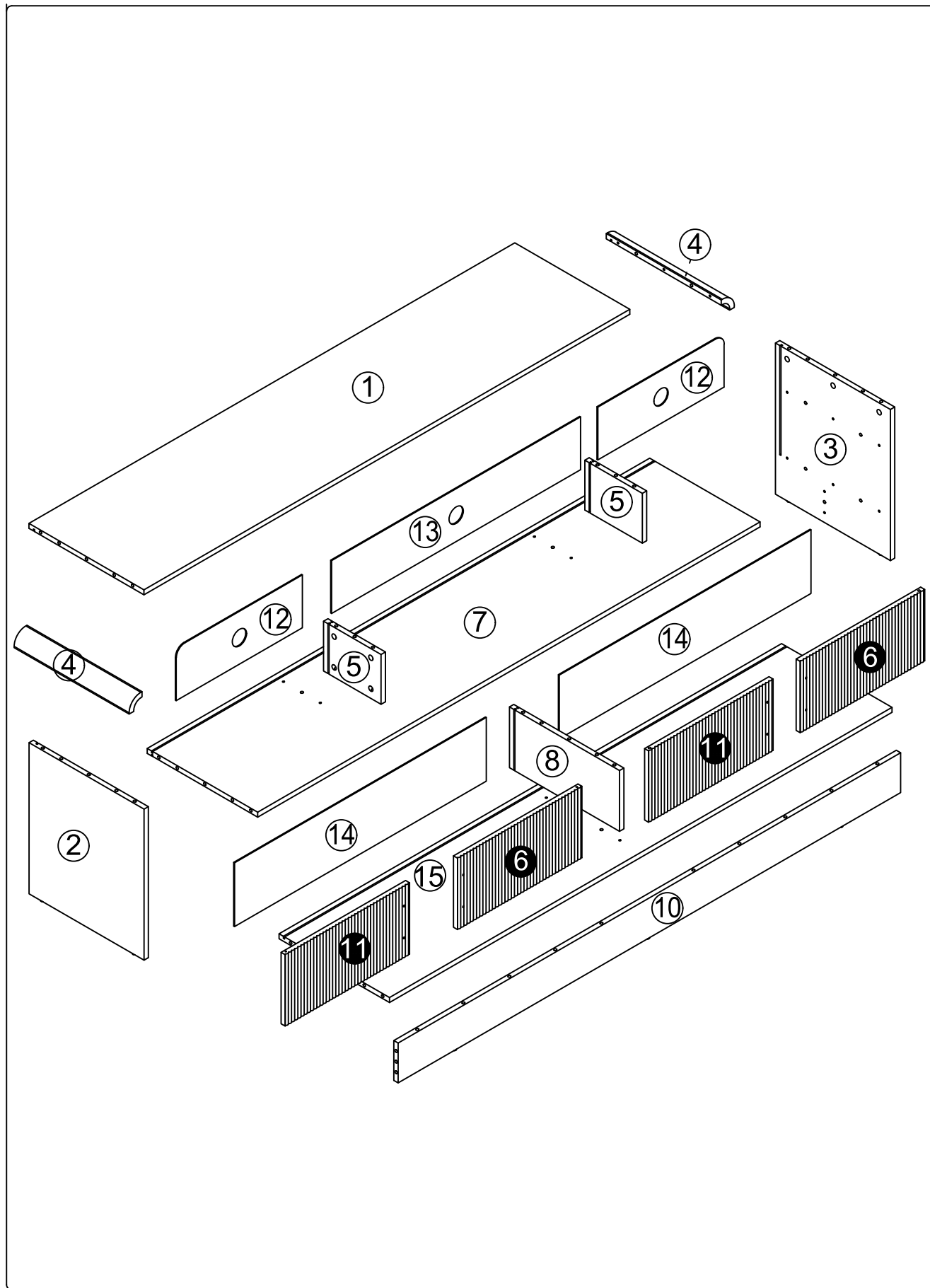

Step 1

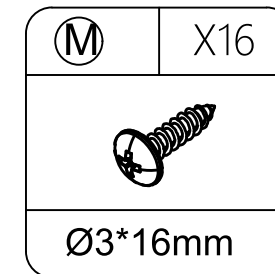
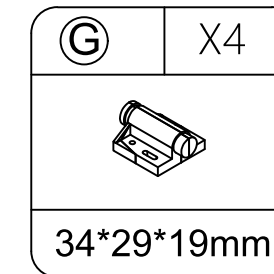
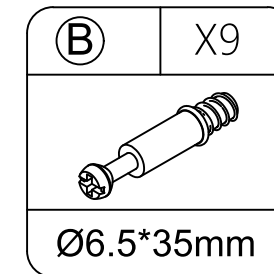
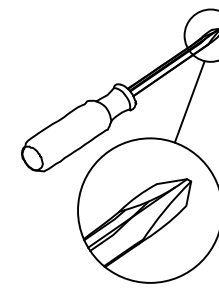

Attach accessory (B) to the plates (7) and (15), attach accessory (M), (G) to plate (7).

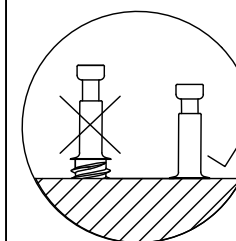
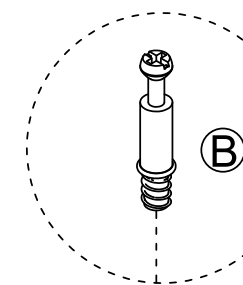
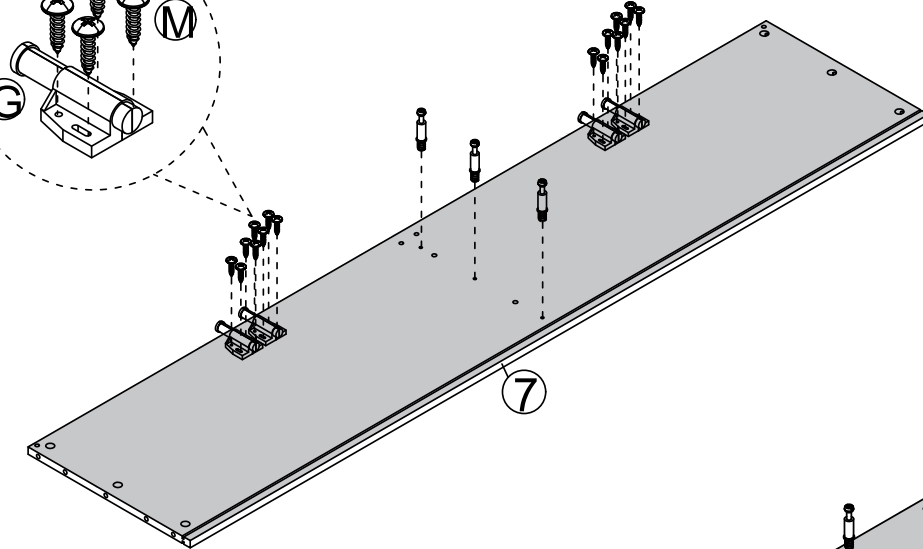
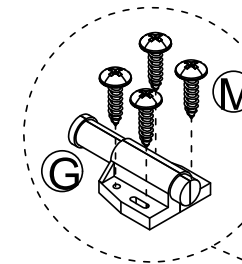

Step 2

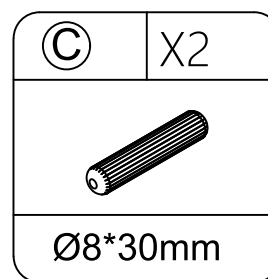
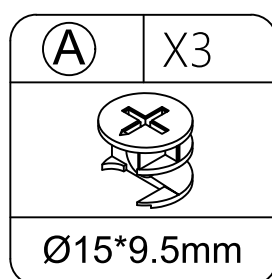
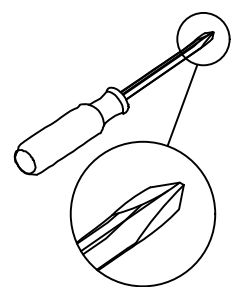

Insert accessory (C) into the holes of plate (8) to connect plate (7), then secure with accessory (A)

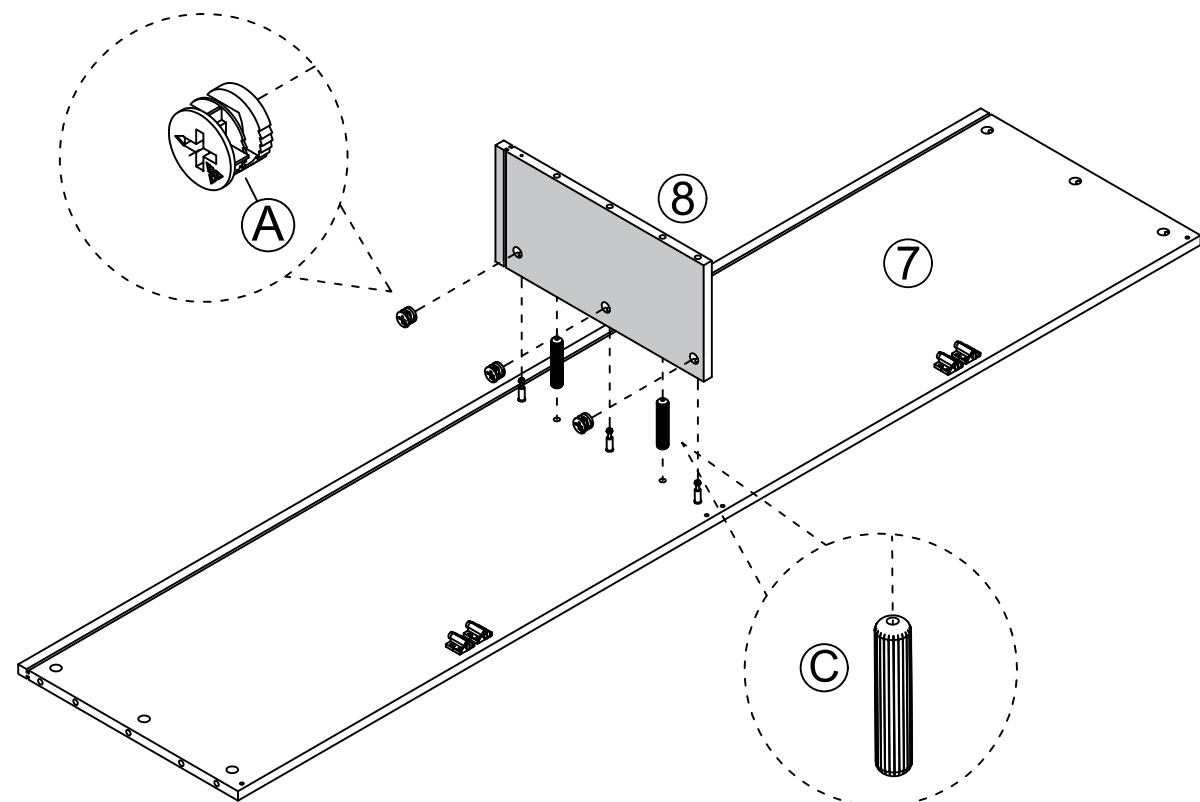

Insert the cam bolt into the hole first, then insert the cam lock and lock it.

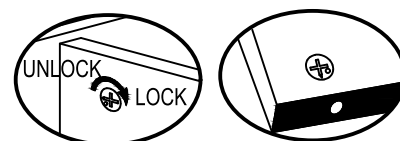

Proper orientation of CAM LOCK

Step 3

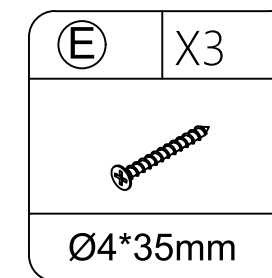
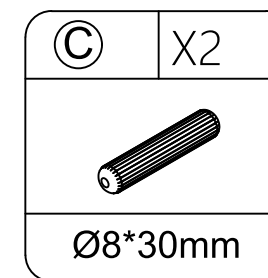
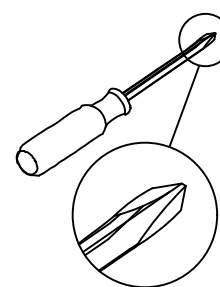

Insert accessory (C) into the plate (8) holes, fix it with screw (E) through plate (15).

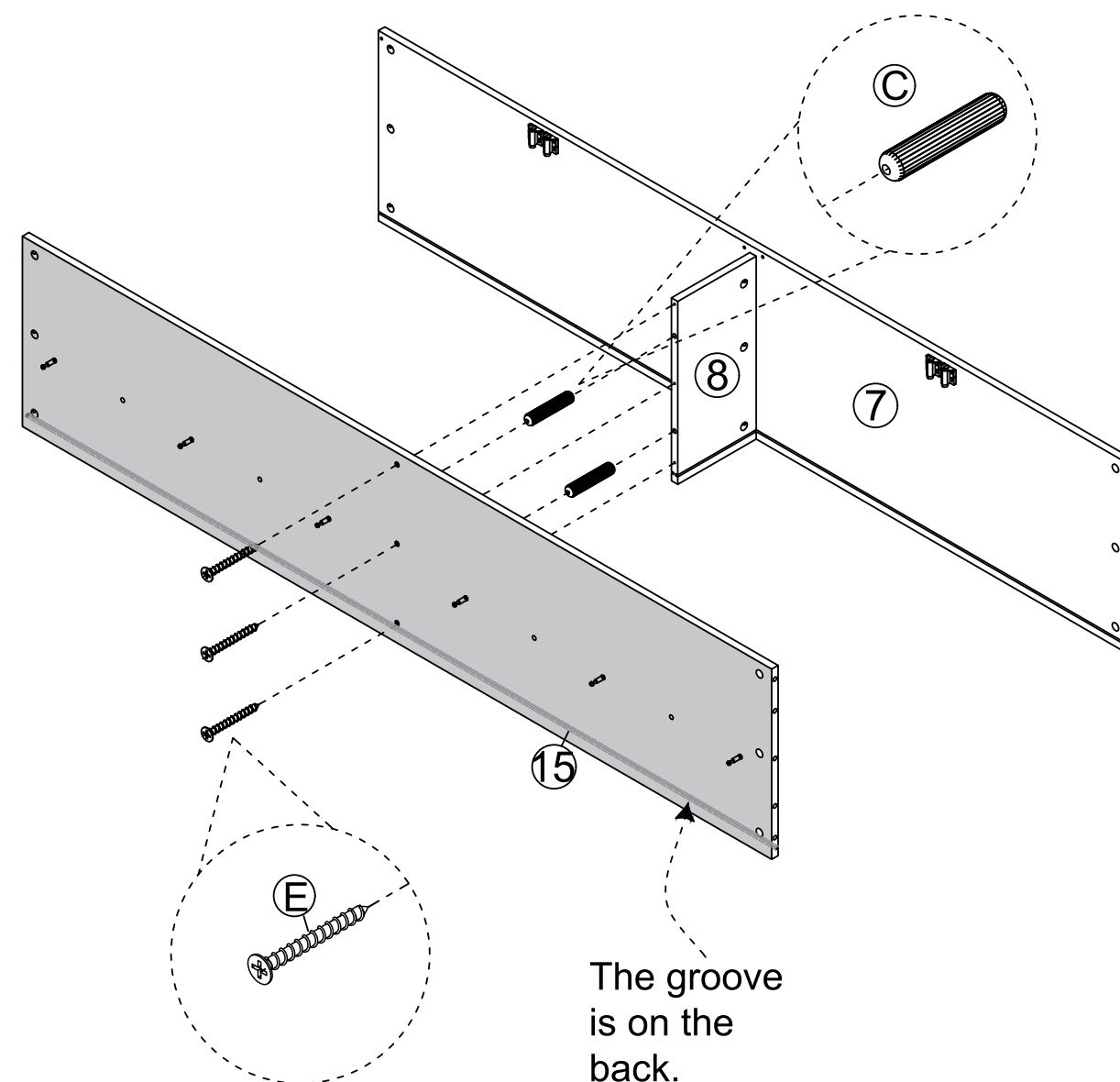

Step 4

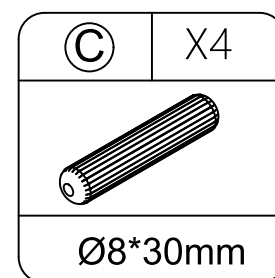
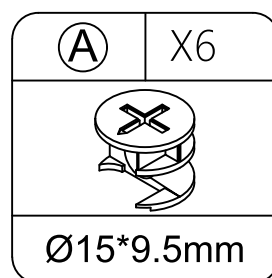
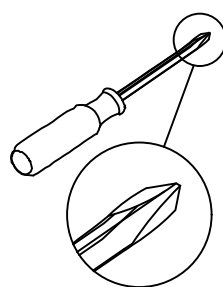

Insert accessory (C) into the plate (10) holes and connect it with plate (15), and fix it with accessory(A).

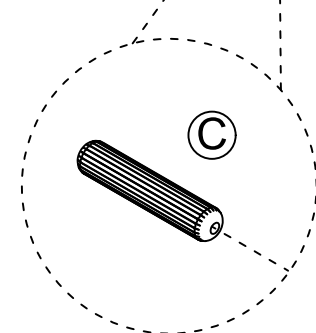
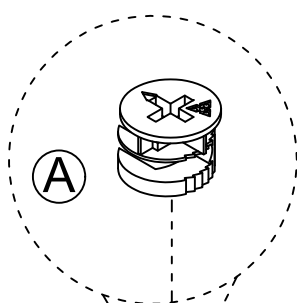
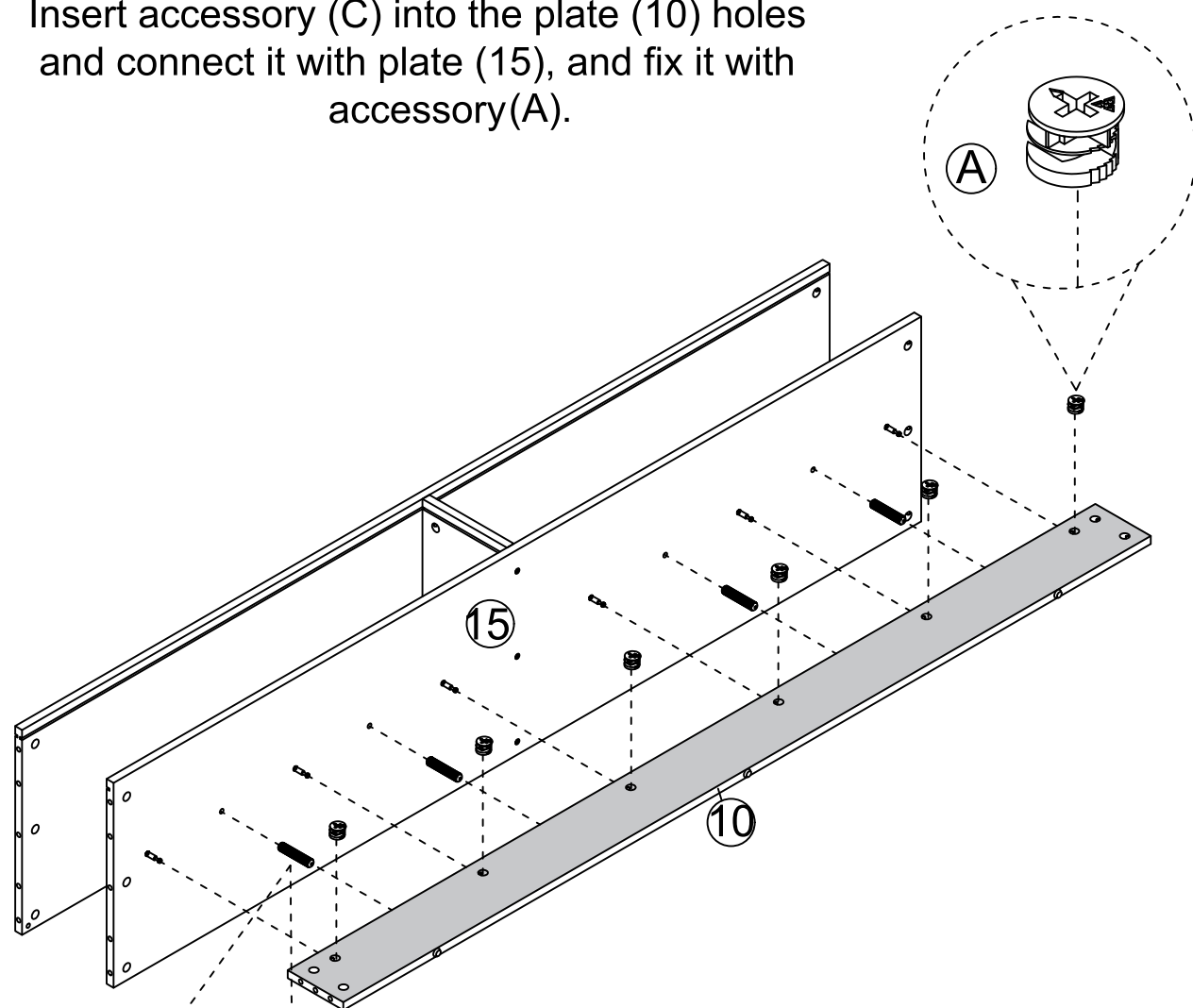

Insert the cam bolt into the hole first, then insert the cam lock and lock it.

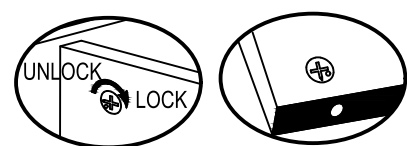

Proper orientation of CAM LOCK

Step 5

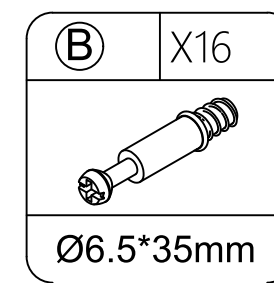
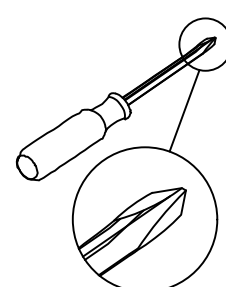

Attach Accessory (B) to plates (2) and (3).

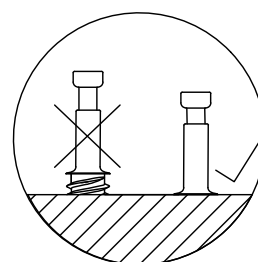
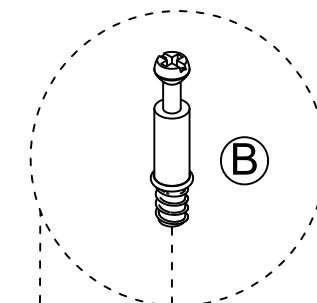
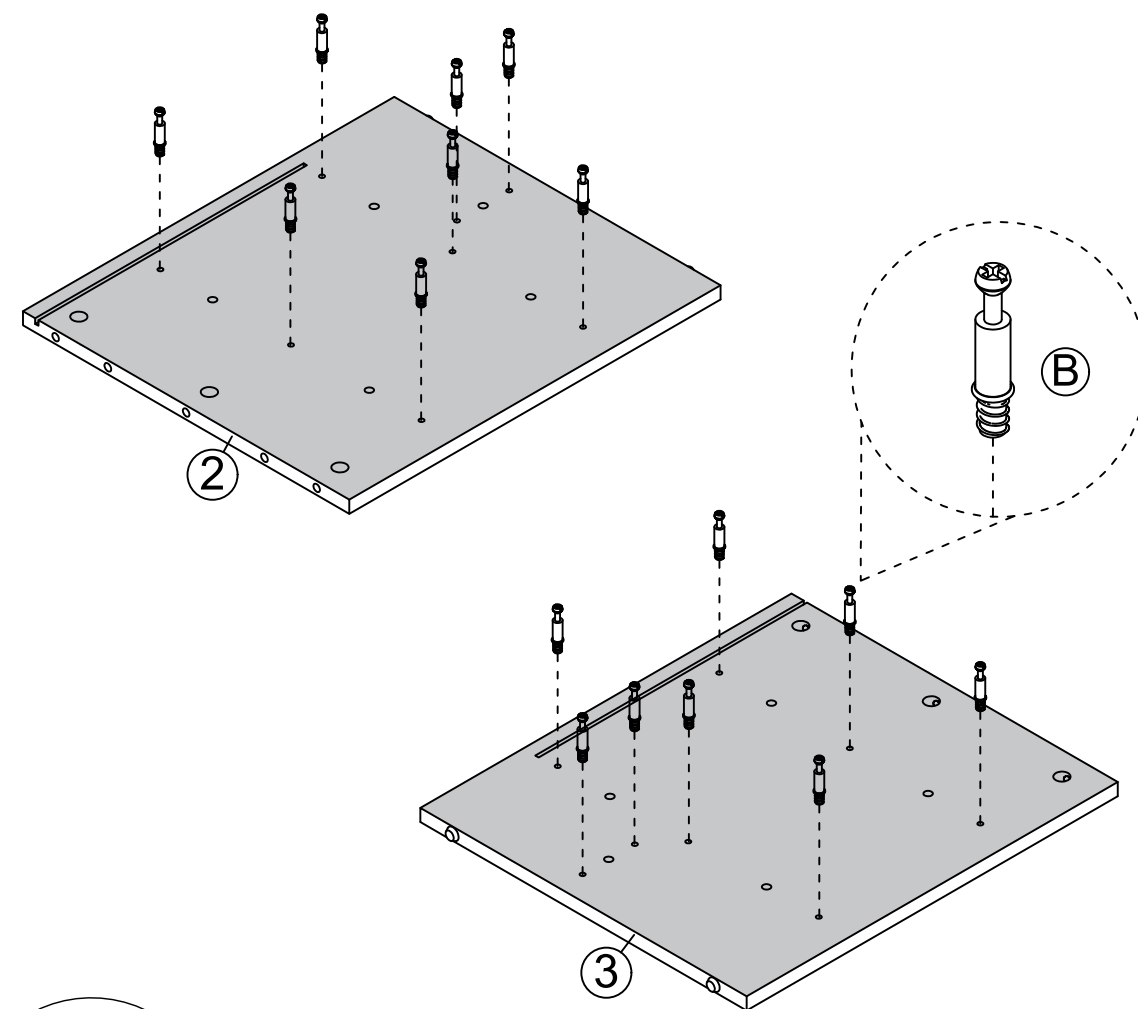

Step 6

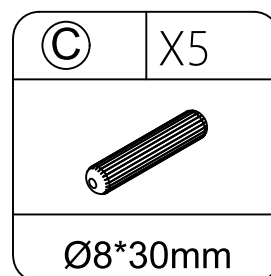
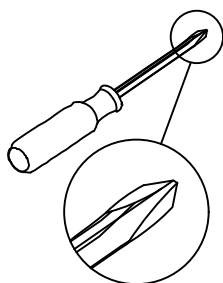

Insert plate (14) along the groove of plates (7) and (15).
Insert accessory (C) into the holes of plates (7), (10) and (15).

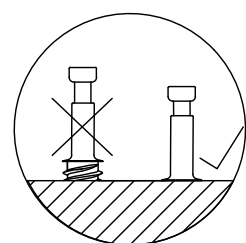
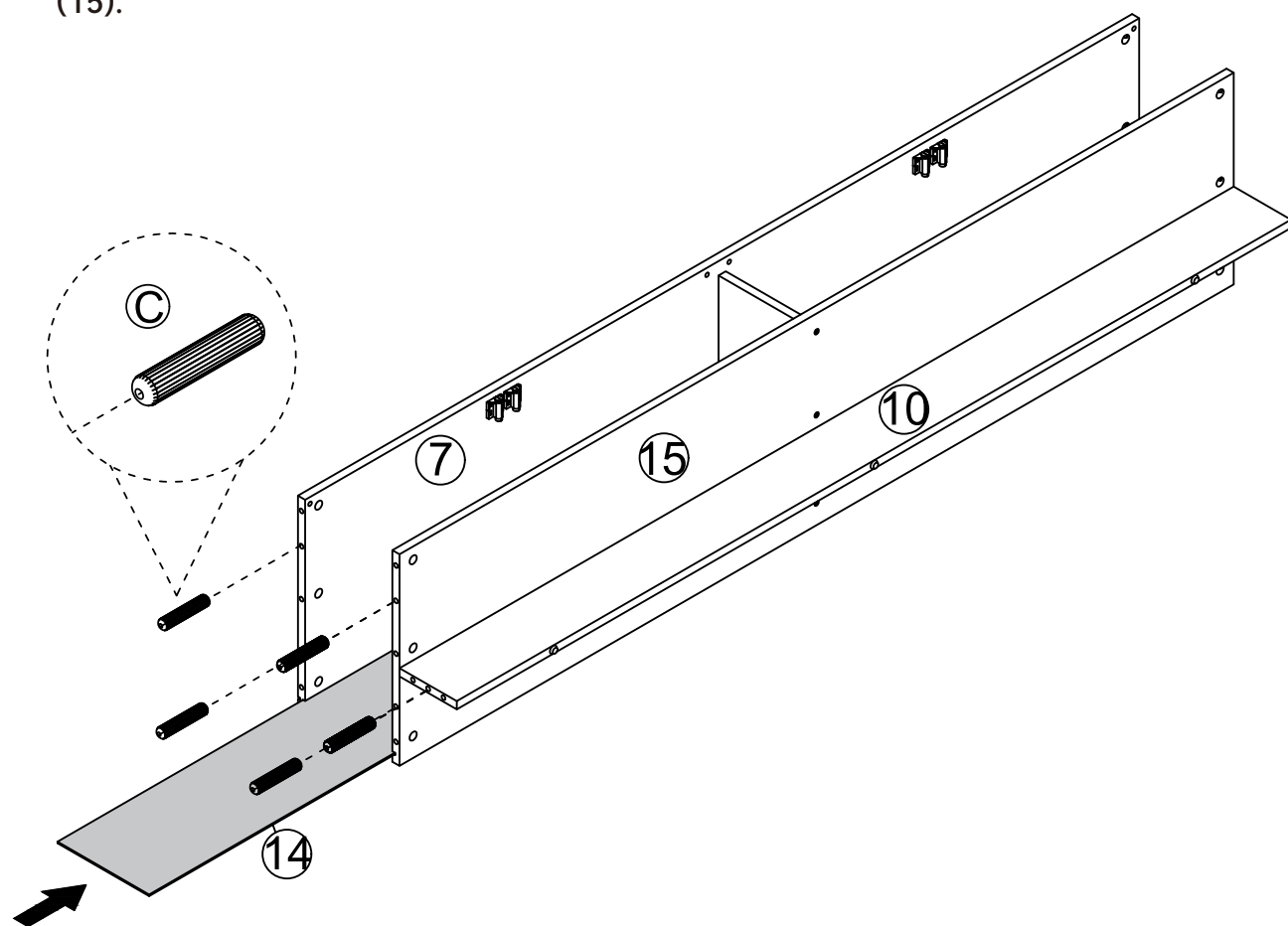

Step 7

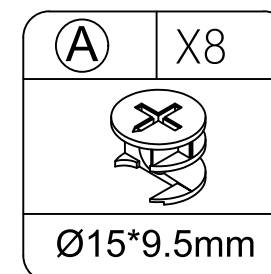
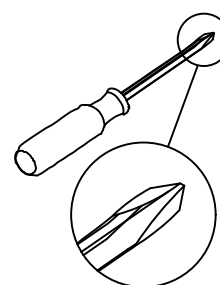

Connect plates (7),(10) and (15) with plate (2) , fix it with accessory (A) .

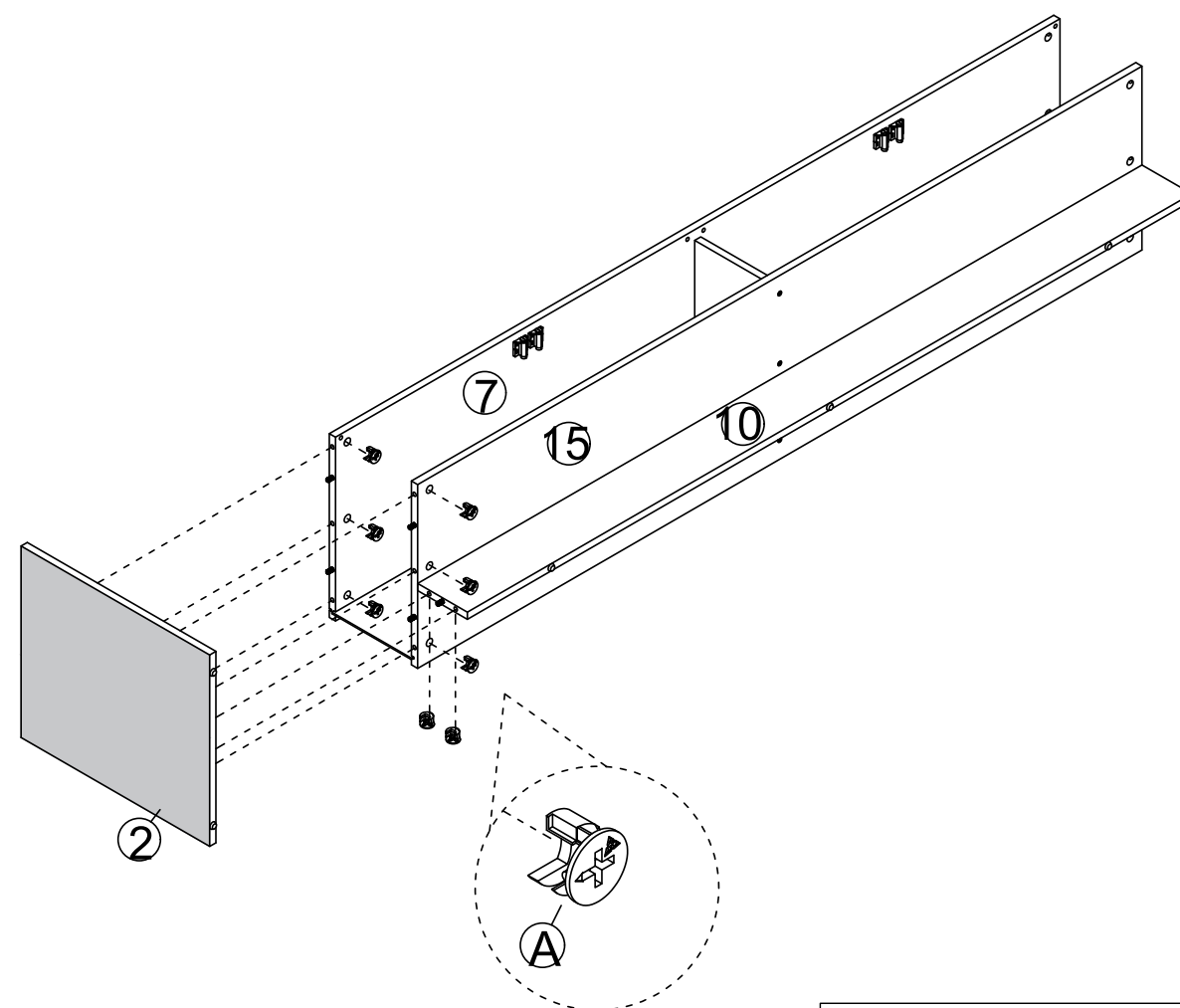

Insert the cam bolt into the hole first, then insert the cam lock and lock it.

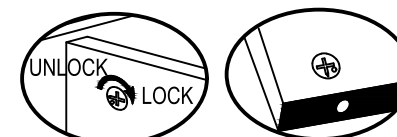

Proper orientation of CAM LOCK

Step 8

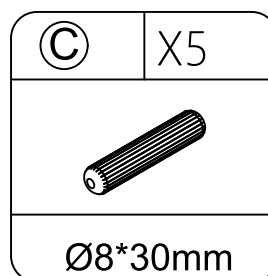
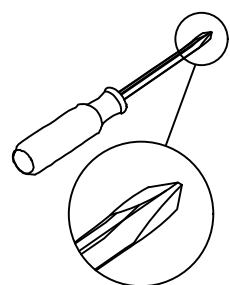

Insert plate (14) along the groove of plates (7) and (15). Insert accessory (C) into the holes of plates (7), (10) and (15).

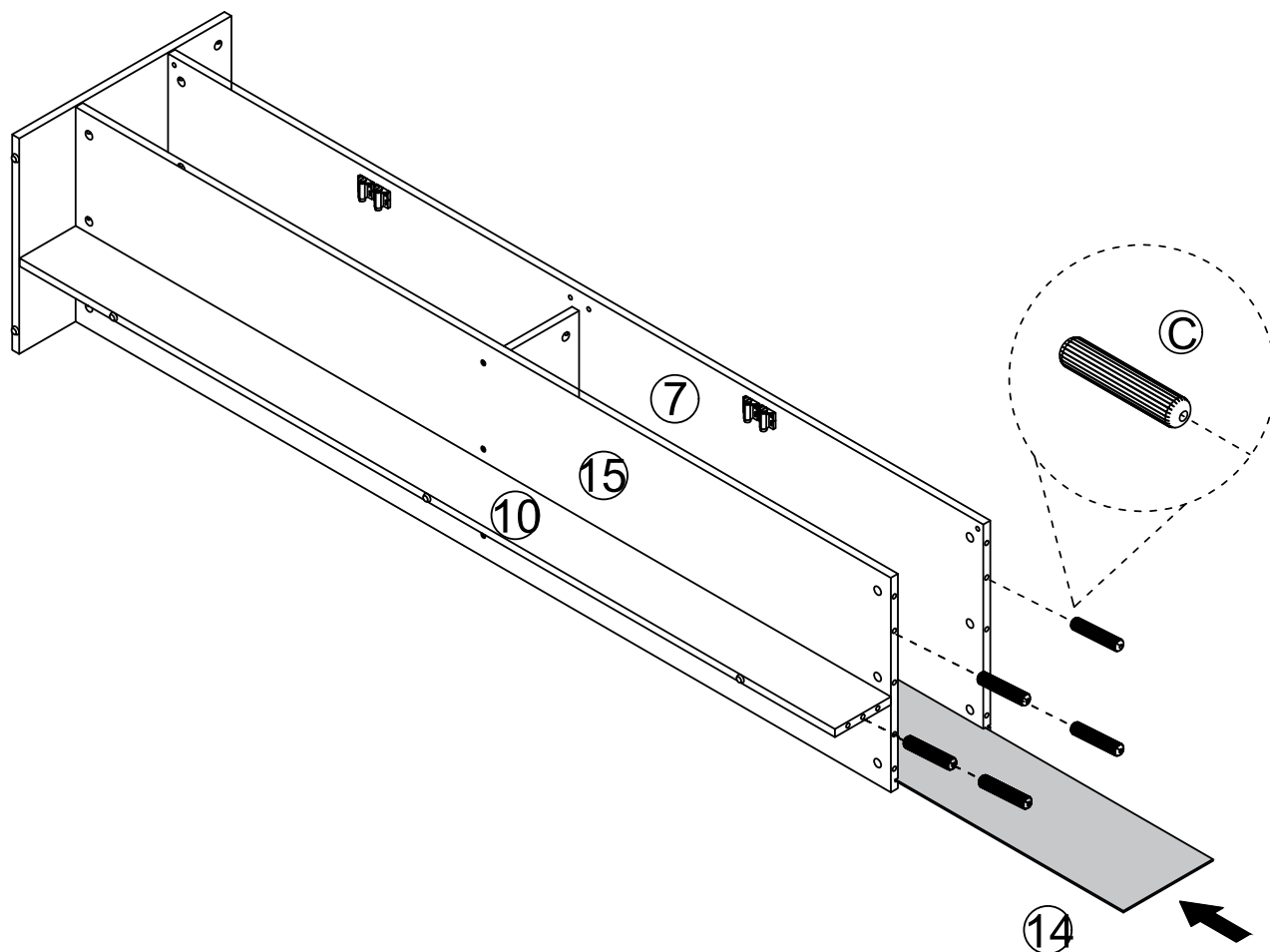

Step 9

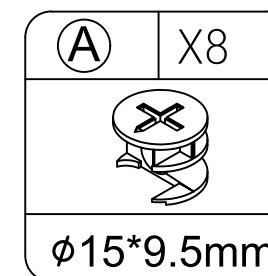
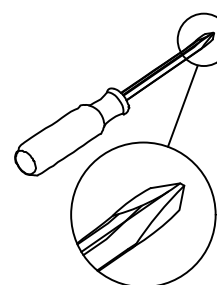

Connect plates (7), (10) and (15) with plate (3), fix it with accessory (A).

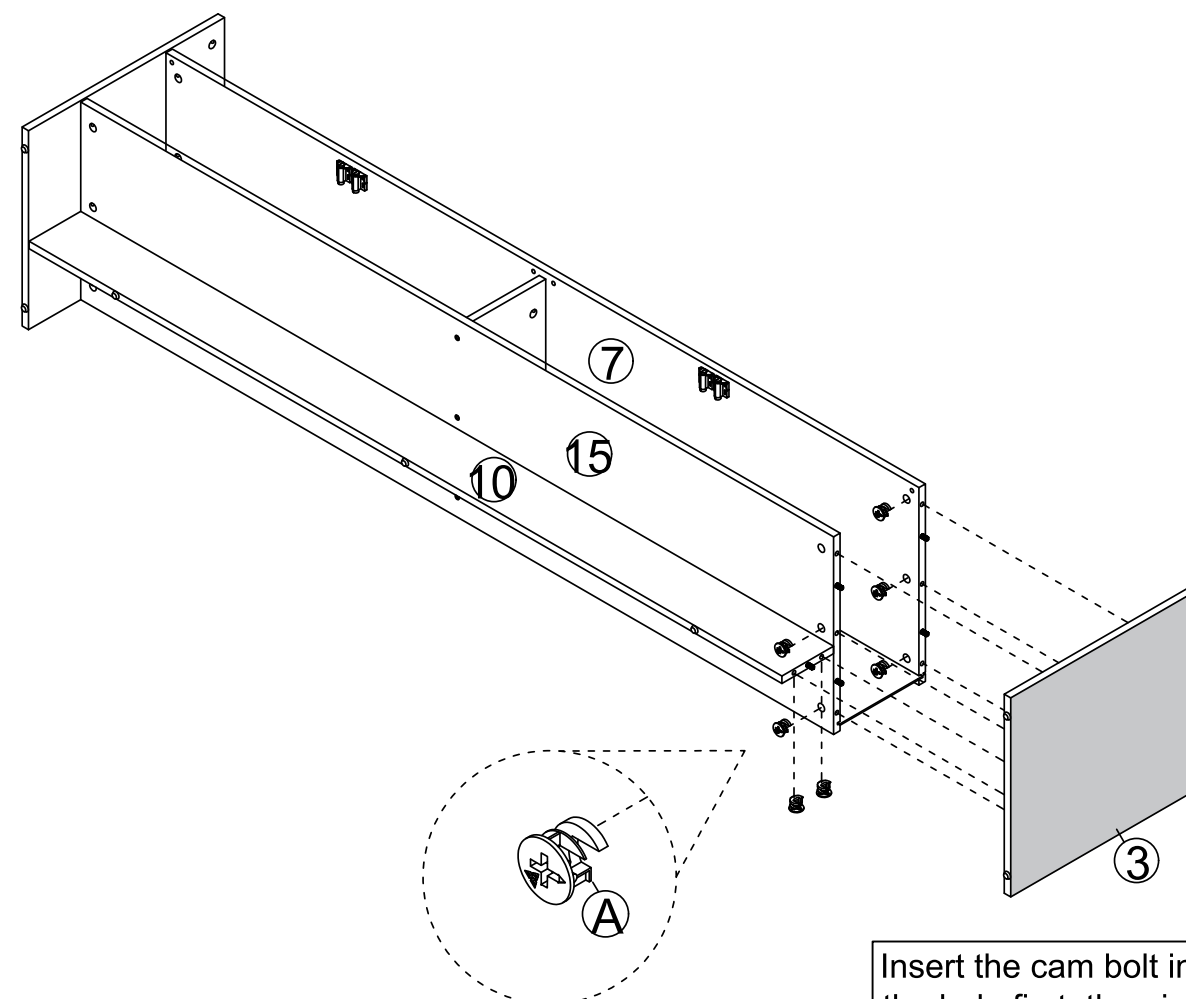

Insert the cam bolt into the hole first, then insert the cam lock and lock it.

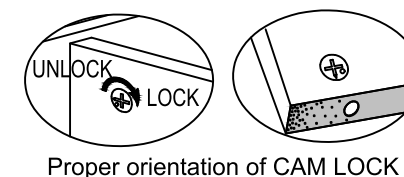

Step 10

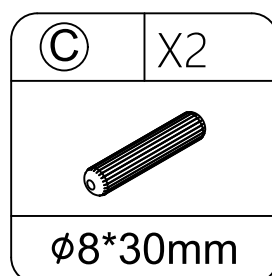
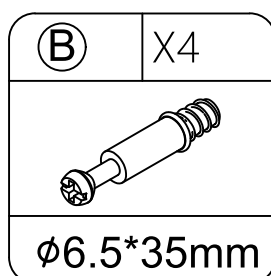
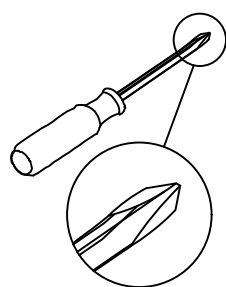

Fix accessory (B) onto plate (7), then insert accessory (C) into the holes of plate (7).

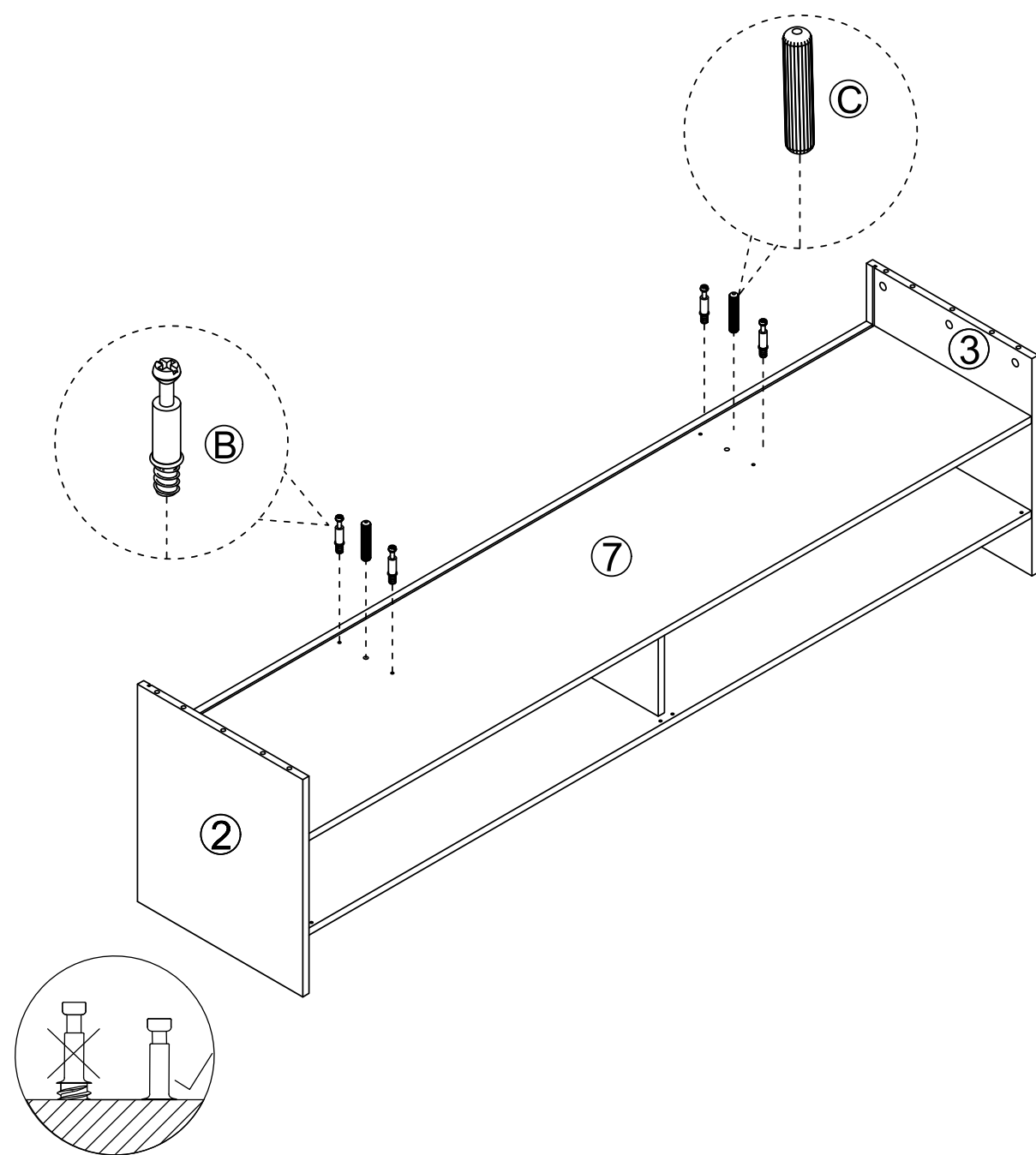

Step 11

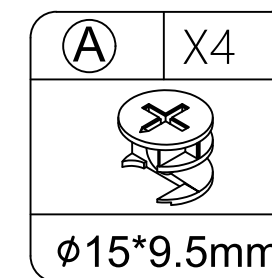
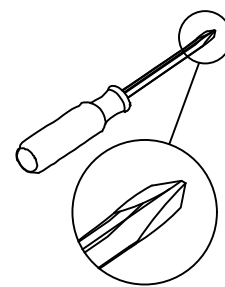

Connect plate (5) to plate(7), then secure it using accessory (A).

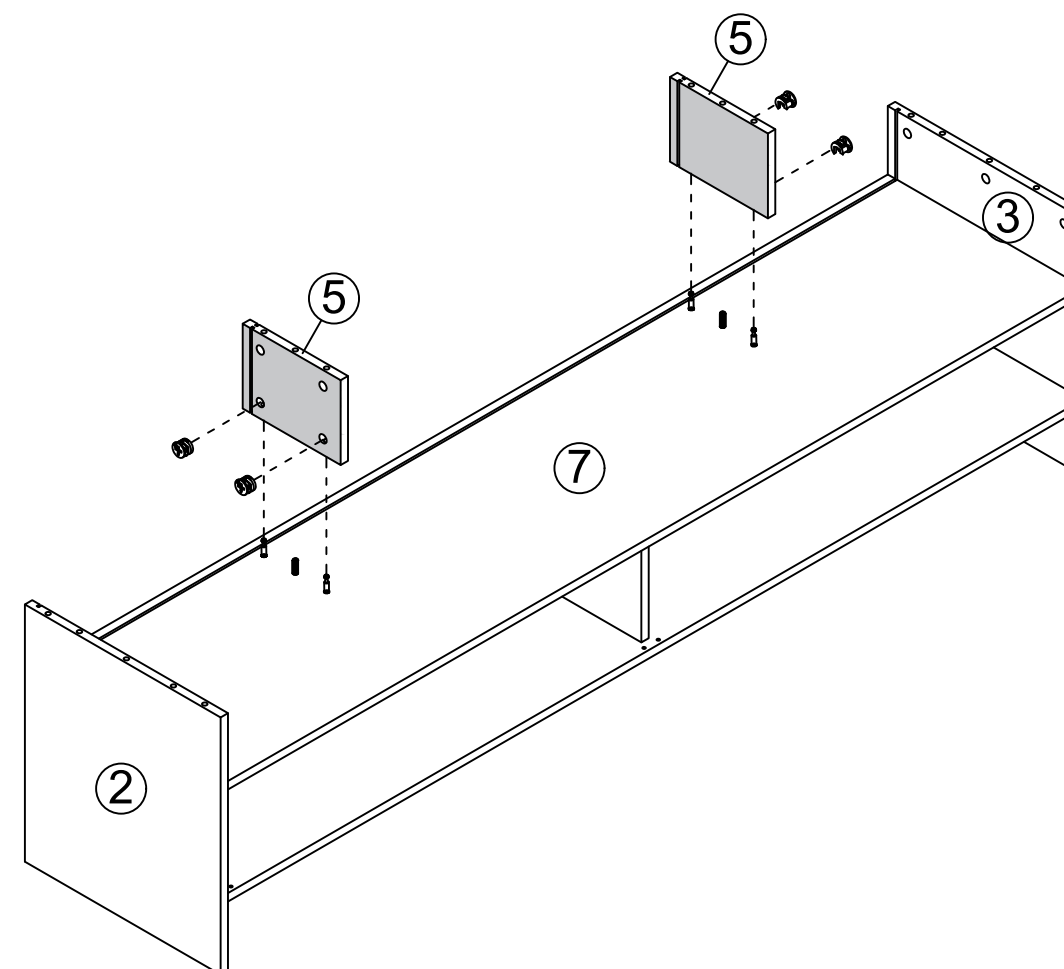

Insert the cam bolt into the hole first, then insert the cam lock and lock it.

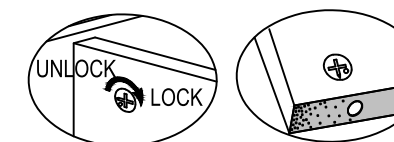

Proper orientation of CAM LOCK

Step 12

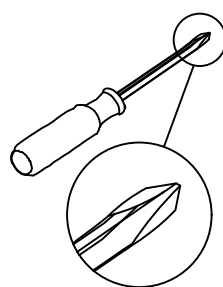

Insert plates (12) and (13) along the grooves of plates (2), (3) and (5).

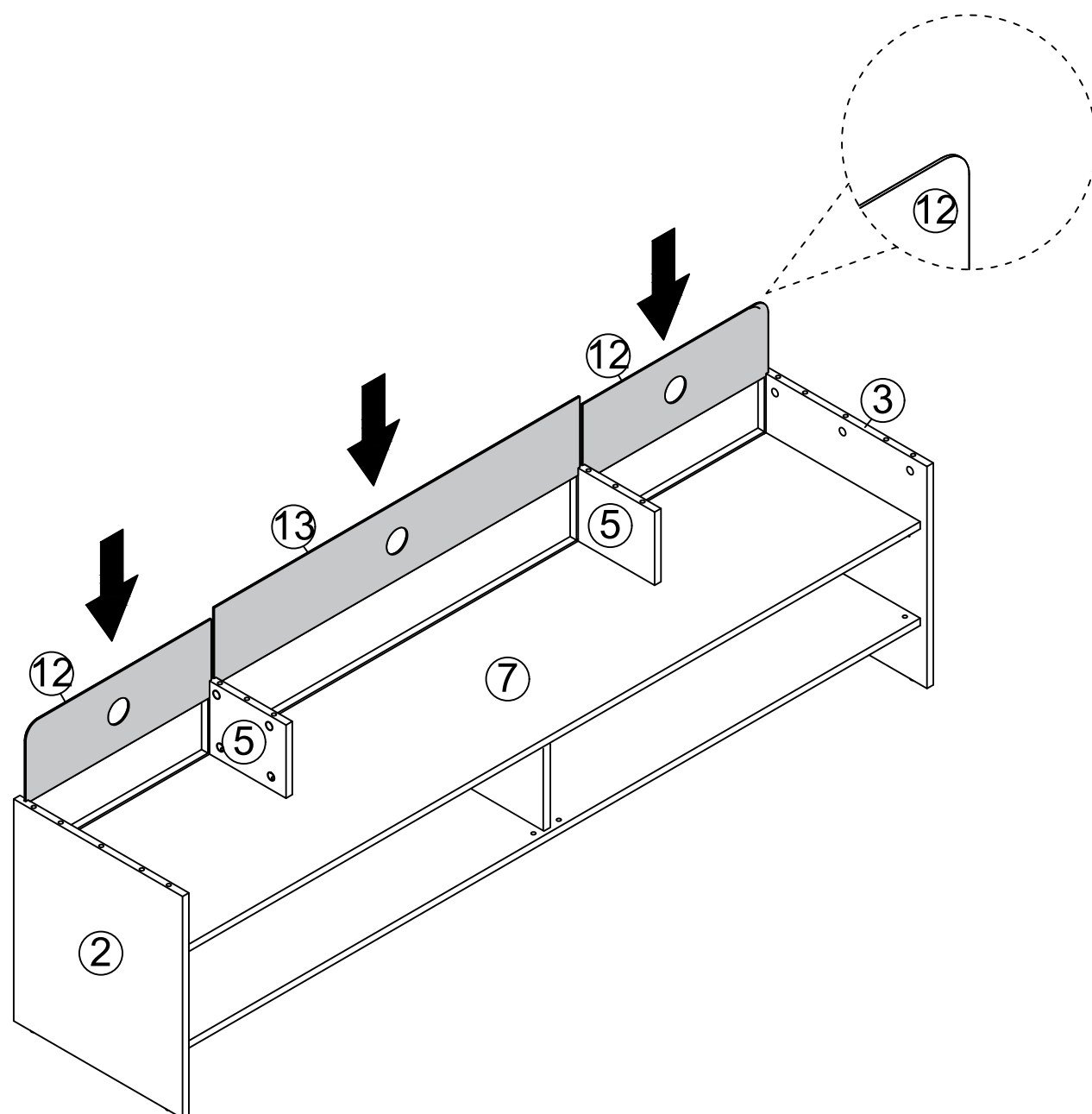

Step 13

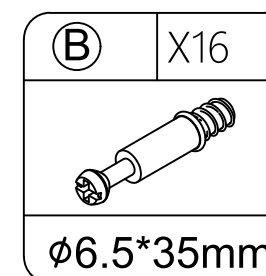
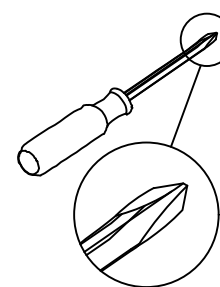

Attach Accessory (B) to plates (1) and (4).

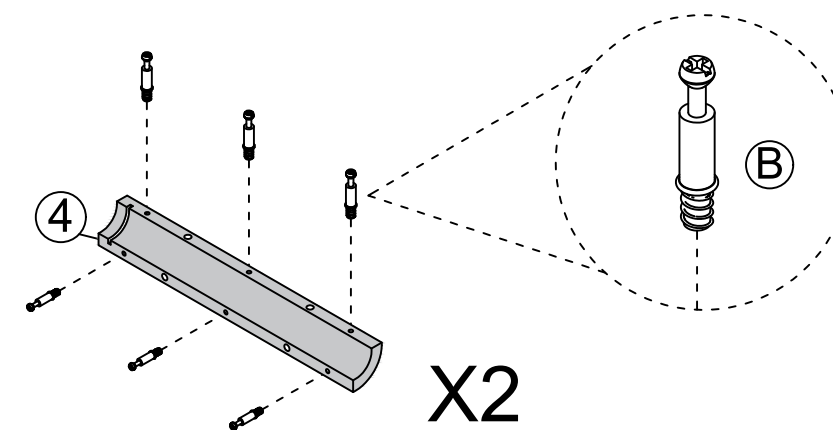

X2

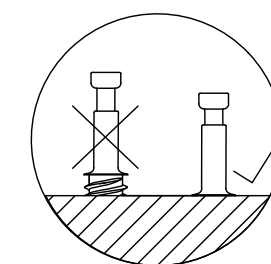
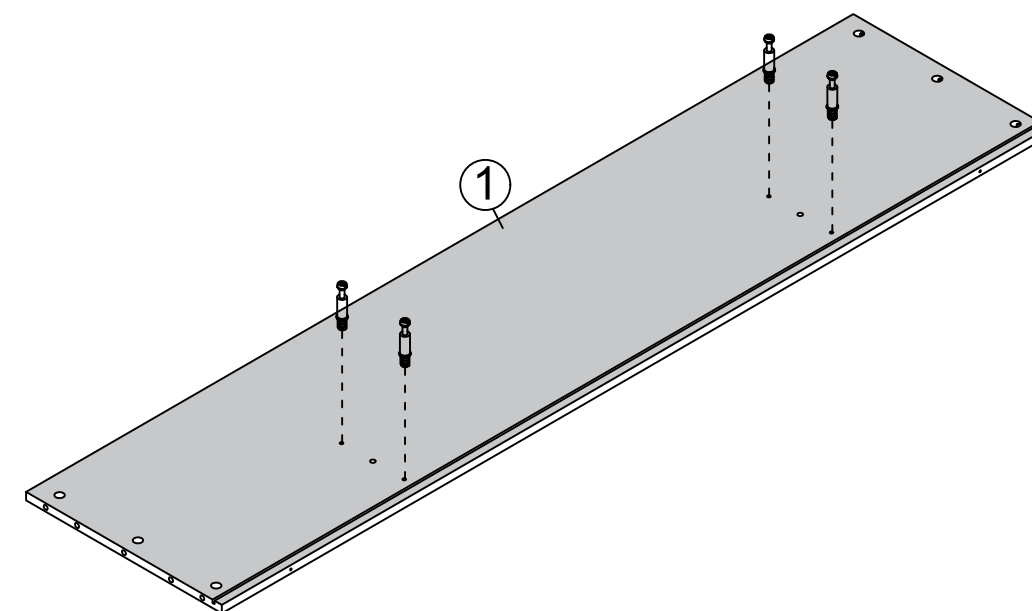

Step 14

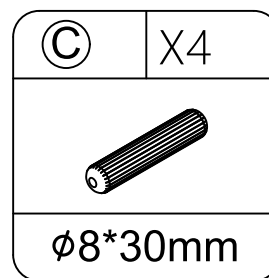
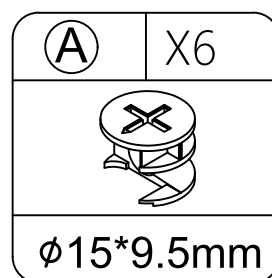
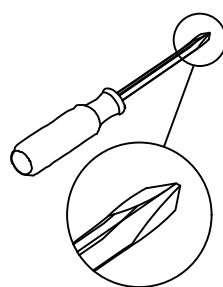

Insert accessory (C) into the hole of plate (1), connect with plate (4), fix it with accessory (A).

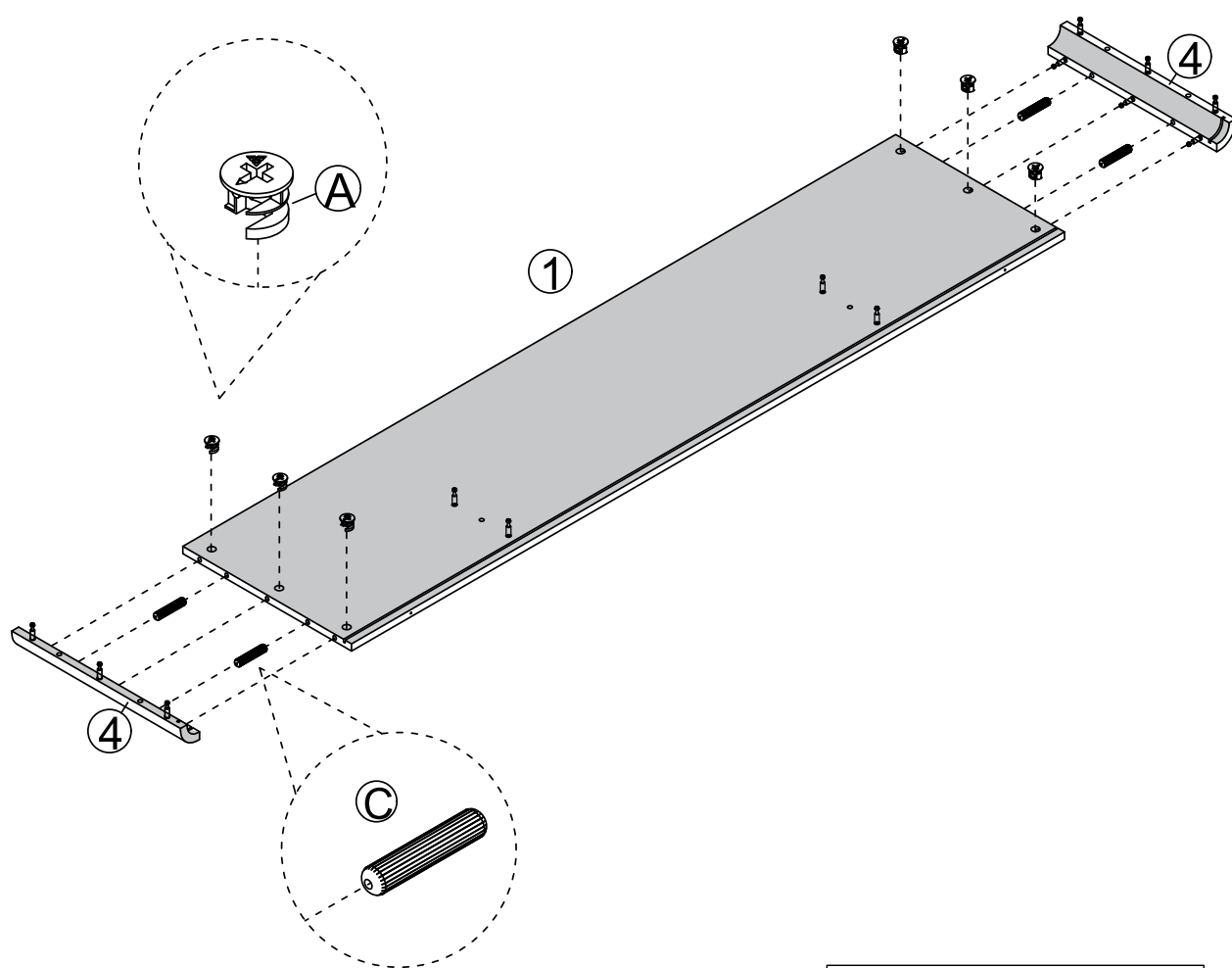

Insert the cam bolt into the hole first, then insert the cam lock and lock it.

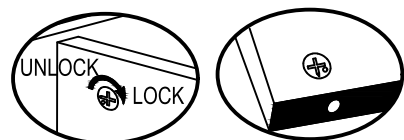

Proper orientation of CAM LOCK

Step 15

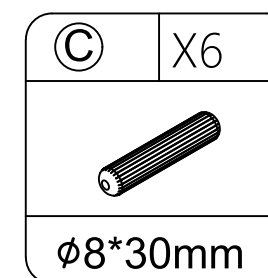
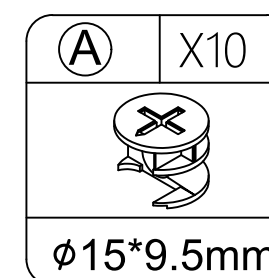
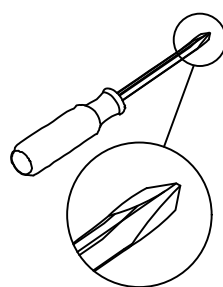

Insert accessory (C) into the holes plates (2), (3) and (5) then connect it panel (1), fix it with accessory (A).

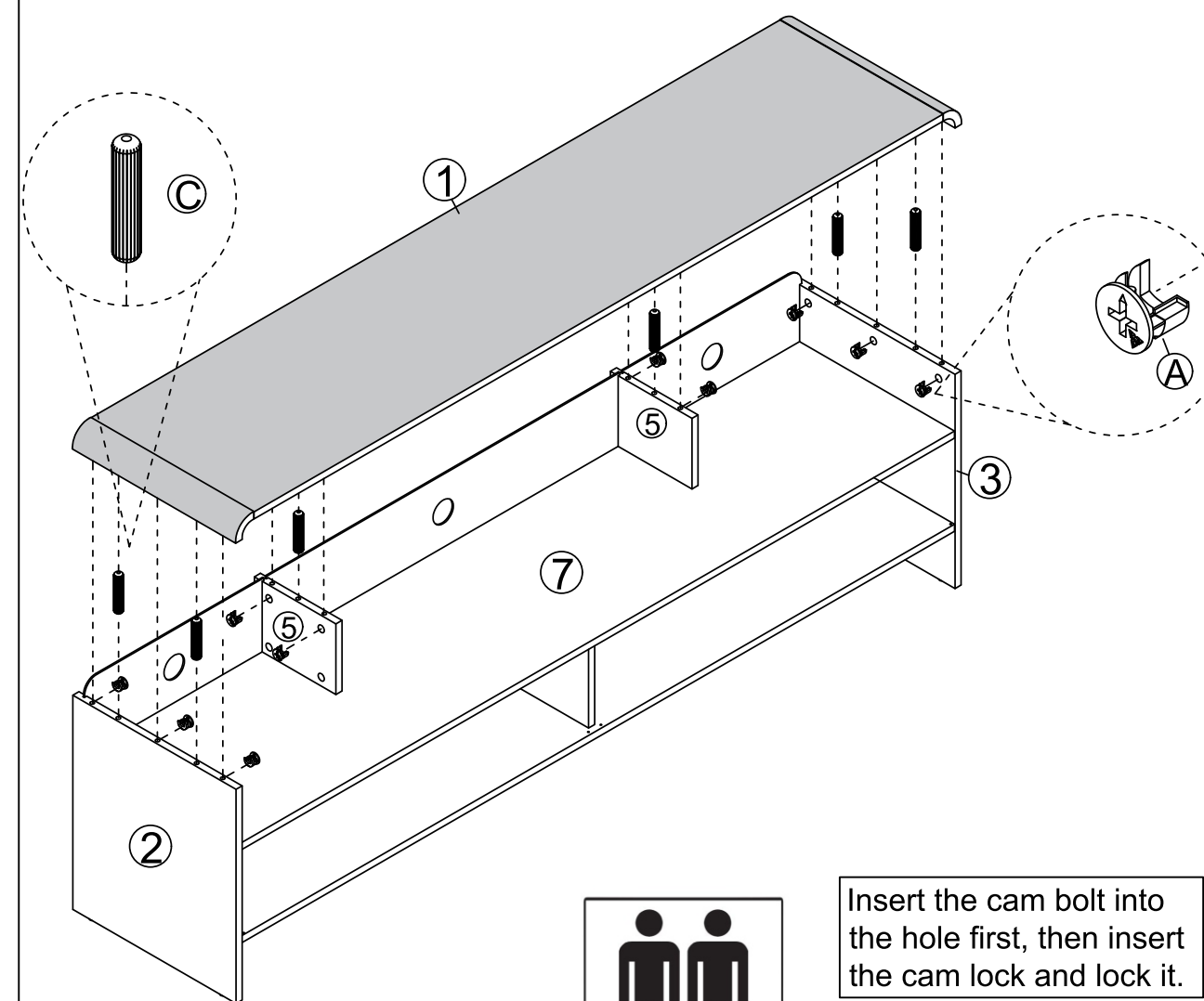

Insert the cam bolt into the hole first, then insert the cam lock and lock it.

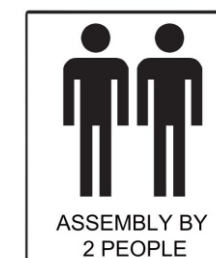

ASSEMBLY BY
2 PEOPLE

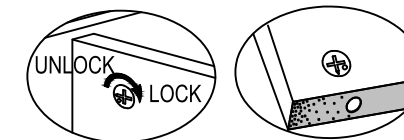

Proper orientation of CAM LOCK

Step 16

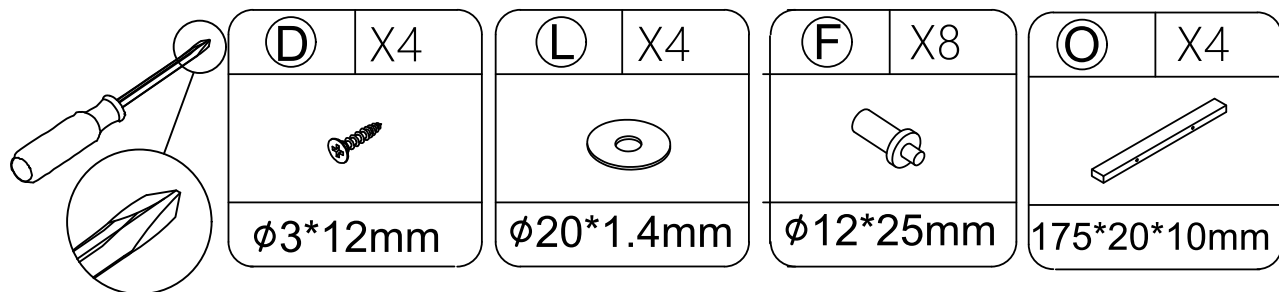

Use screws (D) to separately attach accessory (L) and to plates (11) and (6), and then use screws (N) to connect accessory (O) through plates (11) and (6), finally, insert accessory (F) into plates (11) and (6) respectively.

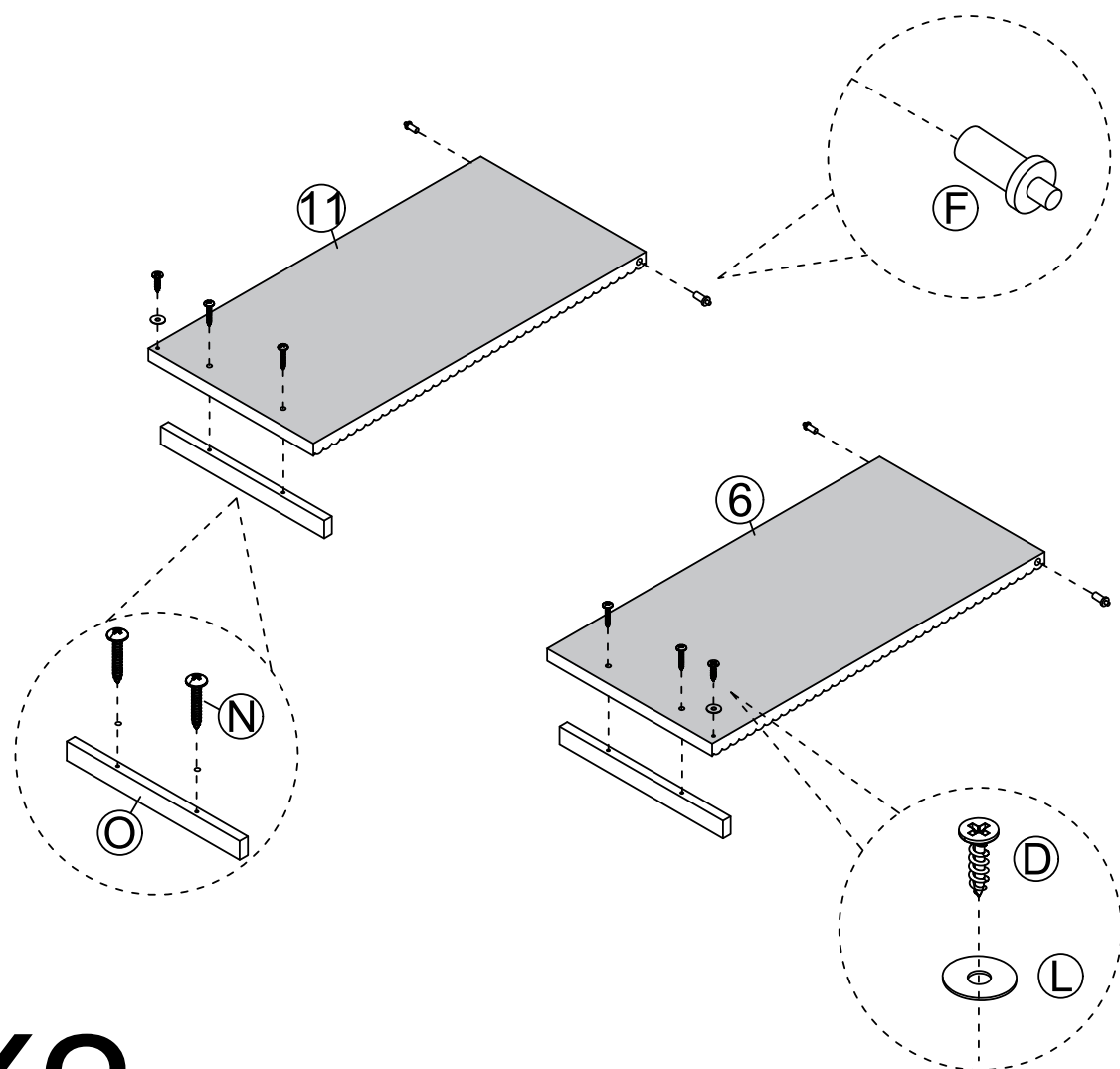
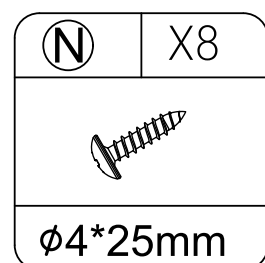

X2

Step 17

Align the location where accessory (F) is installed beneath plate (6) with the corresponding hole on plate (15), then tilt plate (6) and push the upper accessory (F) into the hole on plate (7).

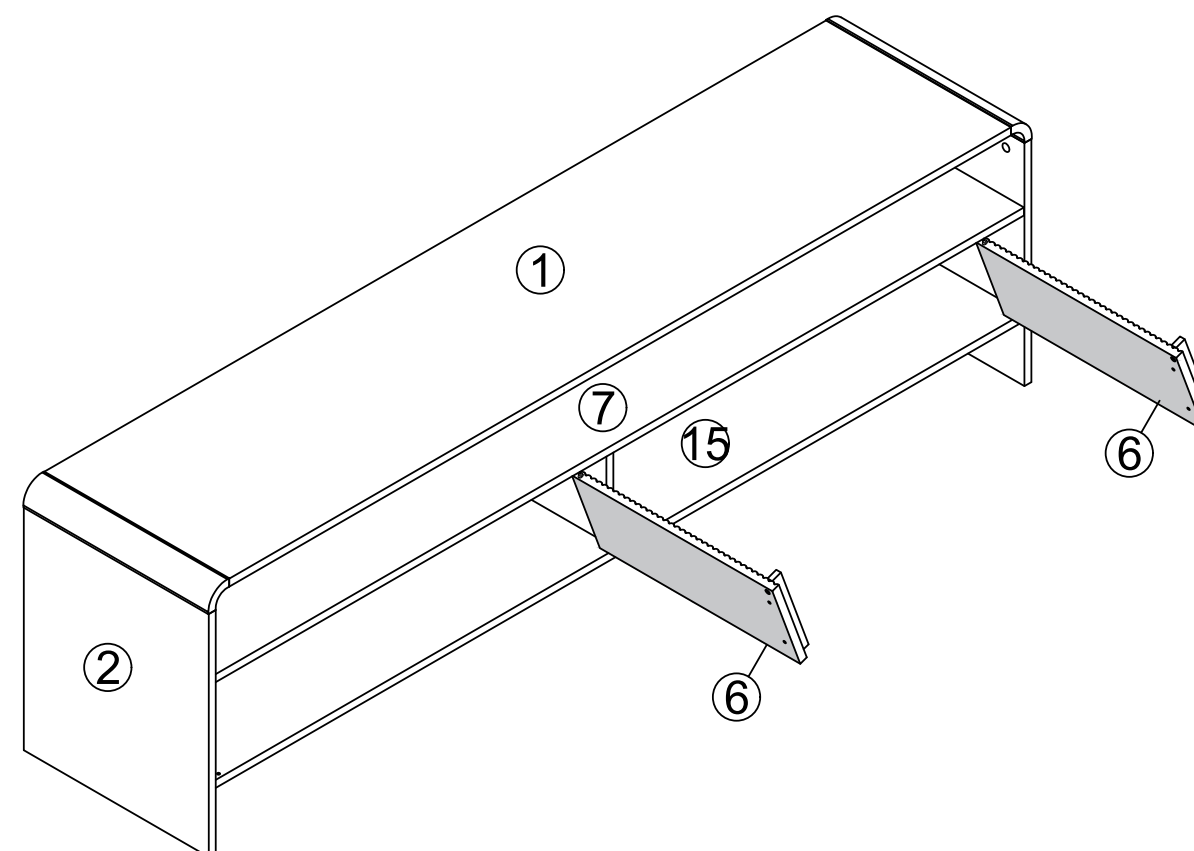

Step 18

Align the position of the accessory (F) beneath plate (11) with the corresponding hole on plate (15), then tilt and push the upper accessory (F) into the hole on plate (7).

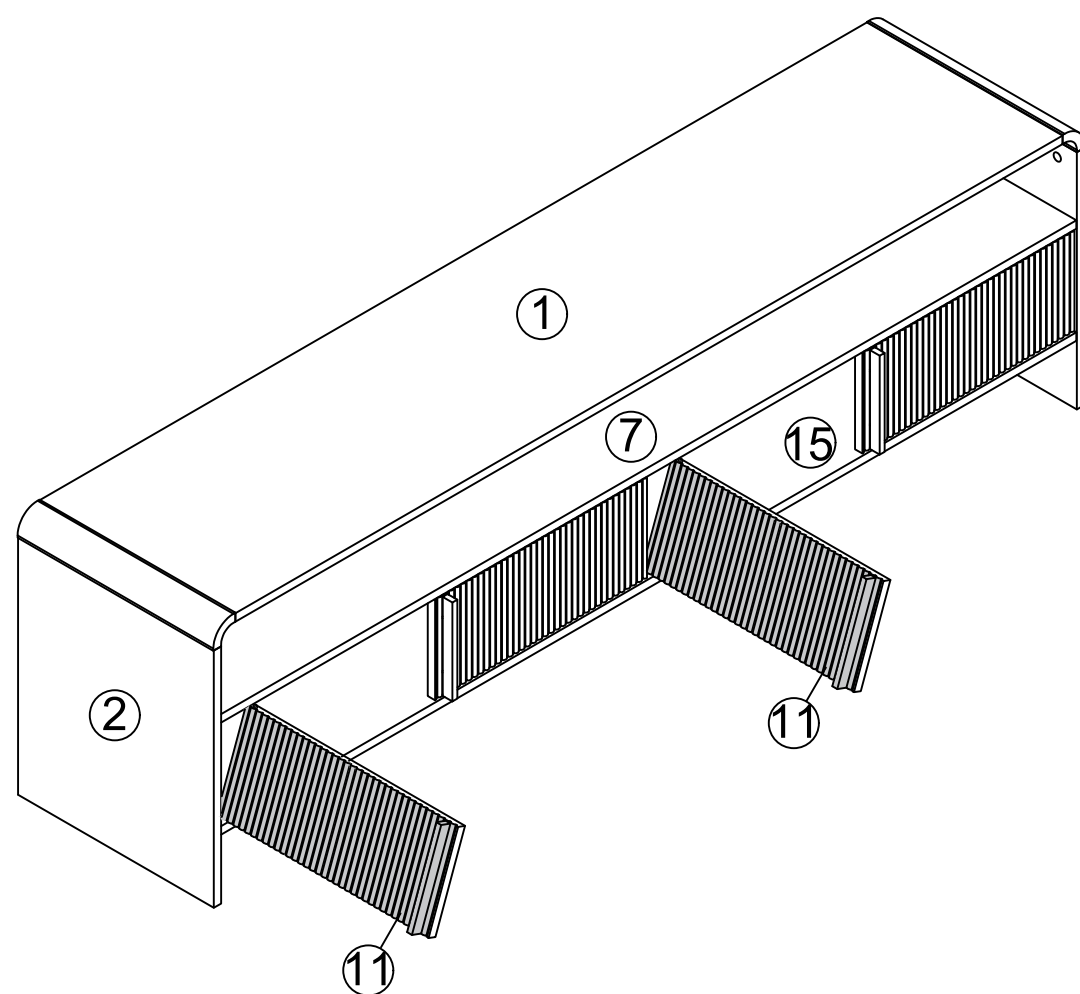

Step 19

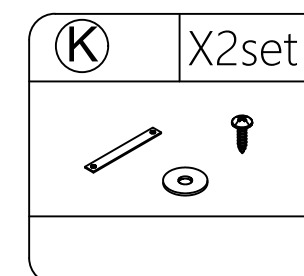
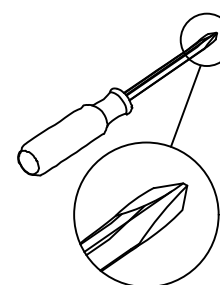

Install accessory (K) on plate (1) as shown.

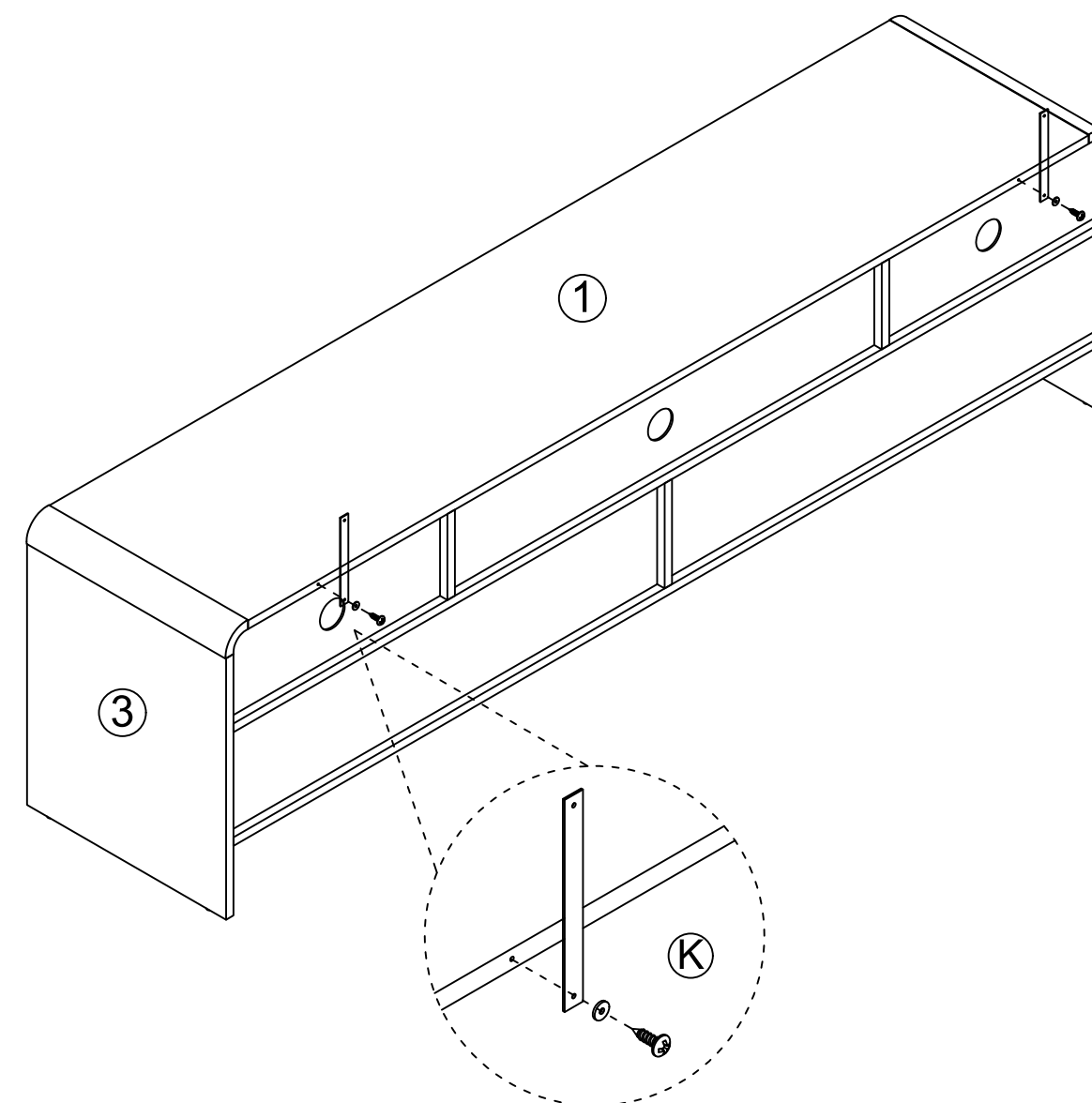

Step 20

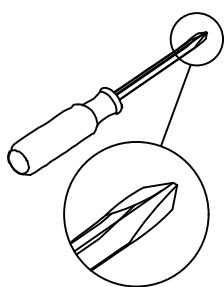

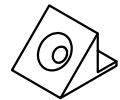
(H)	X19
	
ø3*14mm	

Insert the plastic buckle (H) into the slots (12), (13), (14) of the back plate, screw through the holes in the plastic buckle and lock it in place.

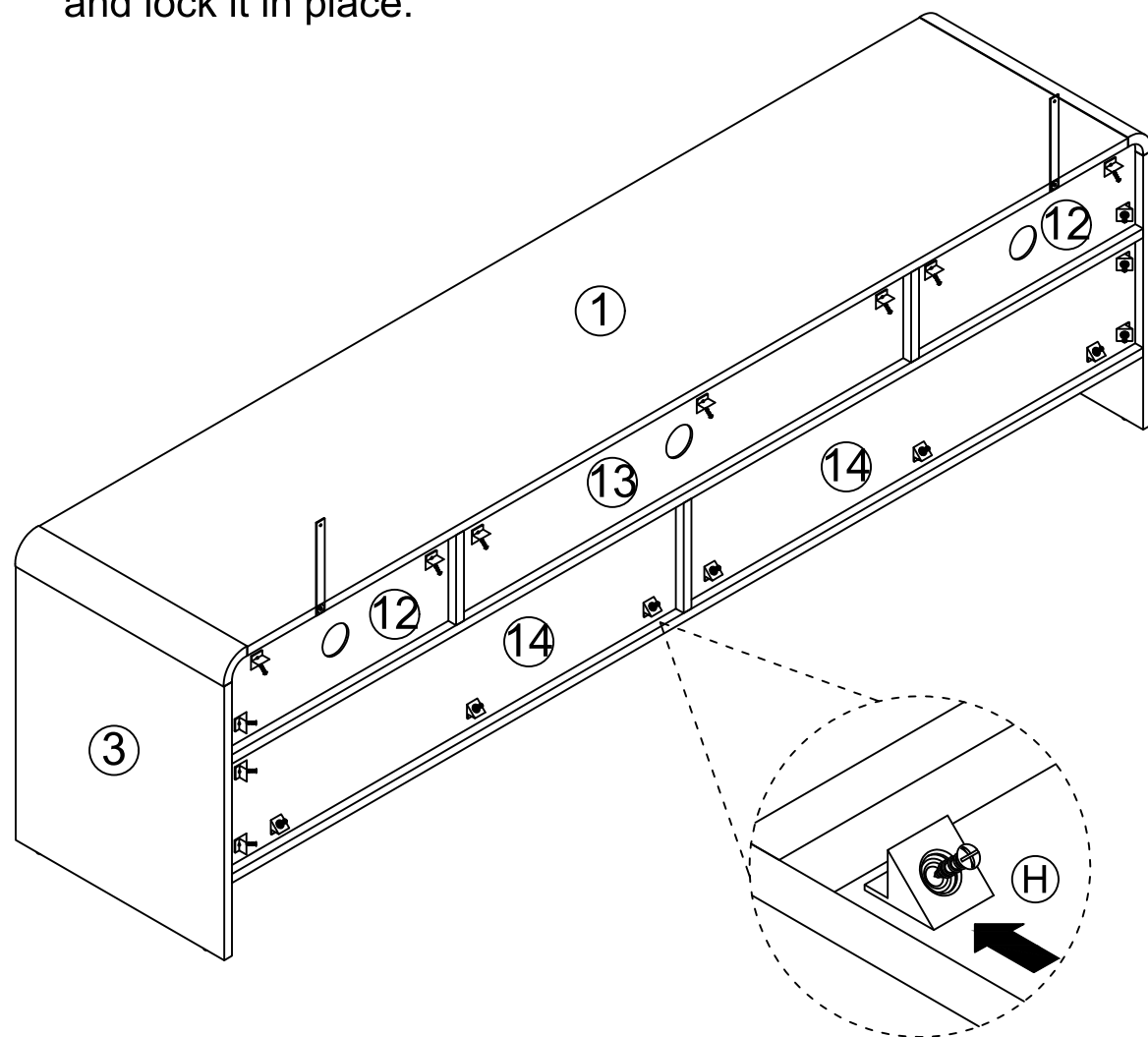

Insert the plastic buckle into the back plate slot, screw through the hole in the plastic buckle and lock it in place.

Step 21

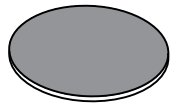
(I)	X45
	
Ø21mm	

Apply 45 screw hole stickers (I) to cover exposed screws and improve the overall appearance. This step may be skipped if desired.

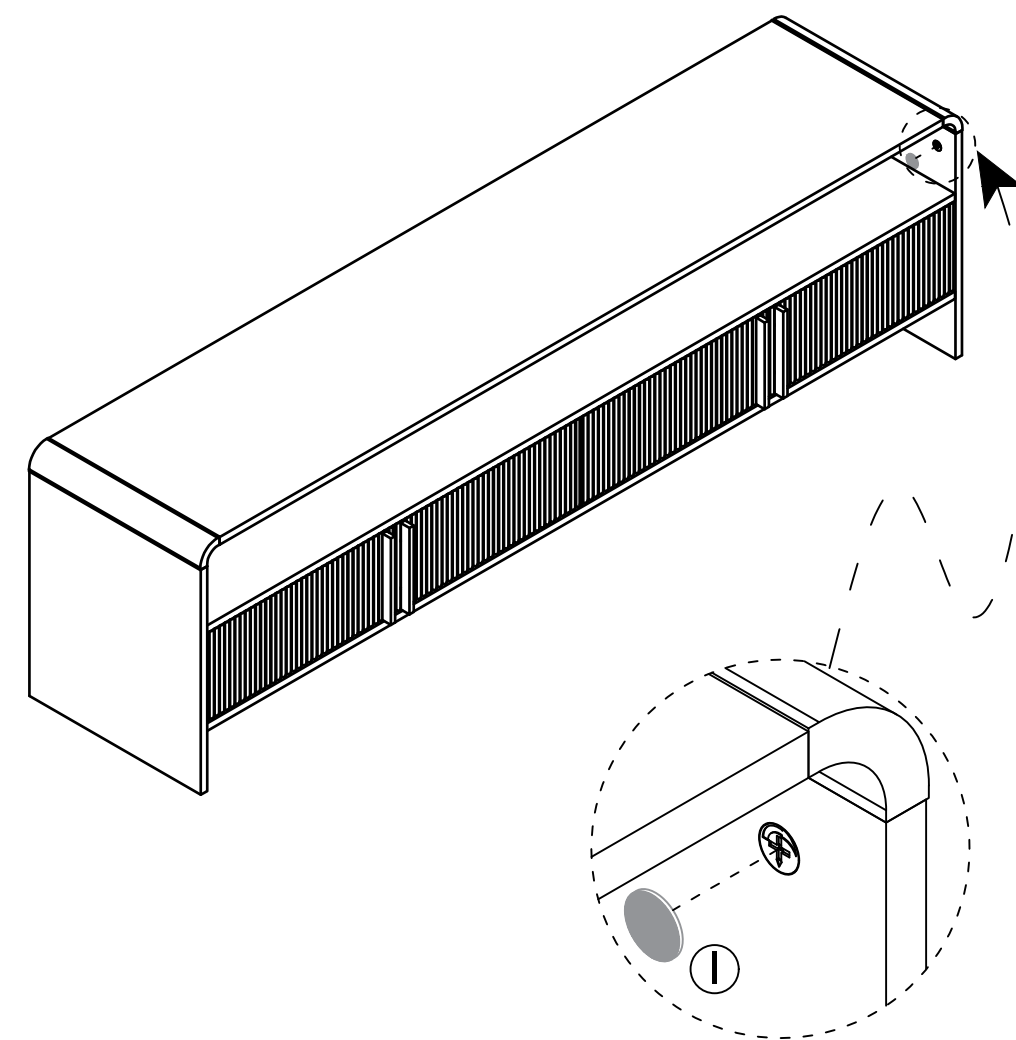

Step 22

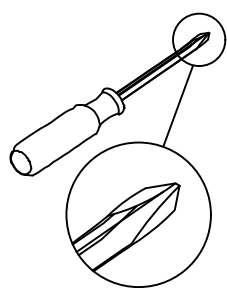

Install the anti-tip hardware:

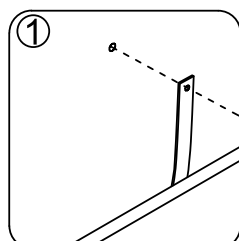

1. Mark the wall.

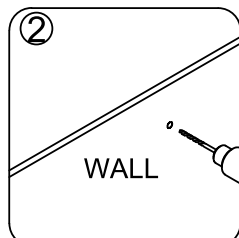

2. Drill two Ø6mm holes on the wall.

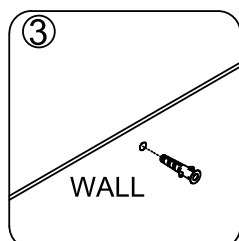

3. Insert two anchors into the holes.

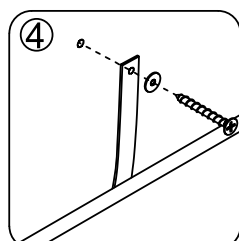

4. Secure the anti-tip hardware to the wall with the long screws.

⚠ WARNING



Children have died from furniture tipover. To reduce the risk of furniture tipover:

- ALWAYS install Anti-tip device provided.
- Maximum TV Size 70" Maximum Load: 50 kg/ 110 lb
- NEVER allow children to stand, climb or hang on drawers, doors, or shelves.

This is a permanent label. Do not remove!

