

Boot Rack

Package Content

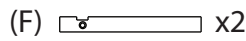

Tools Needed Screwdriver

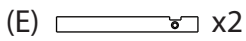
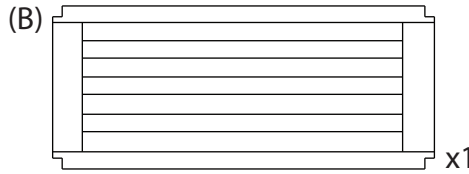
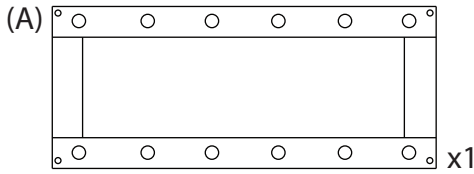
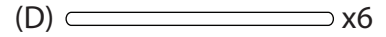
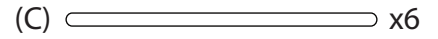

1.

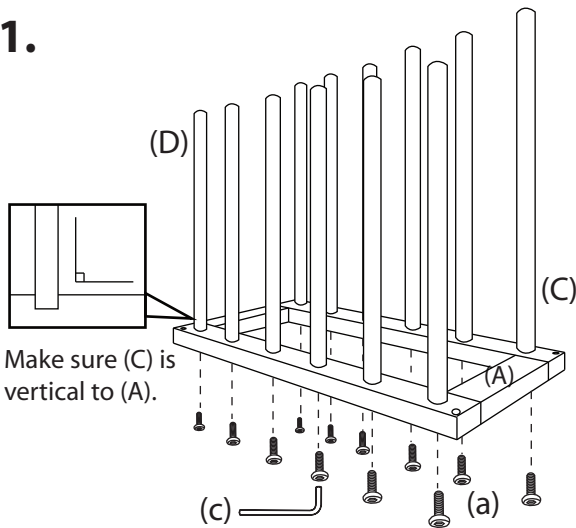

Make sure (C) is vertical to (A).

Put (C) into the larger hole on (A). Screw (a) into (A) and (C), then secure with (c). Repeat with the rest (C)s and (D)s.

2.

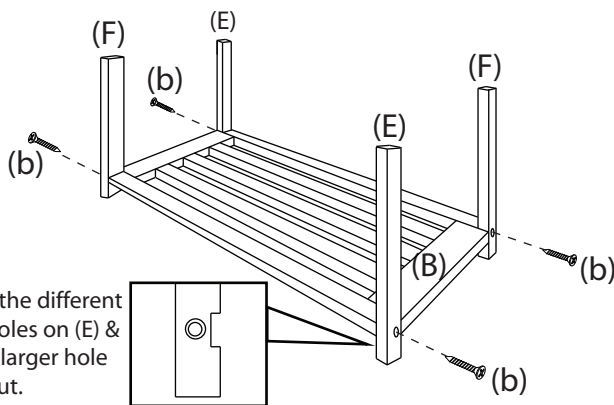

Notice the different sized holes on (E) & (F), the larger hole sides out.

Attach (E)s & (F)s to (B), use a screwdriver to screw HALF (b) into (B). If you locked (b) insecure, it will be difficult to connect with (A).

3.

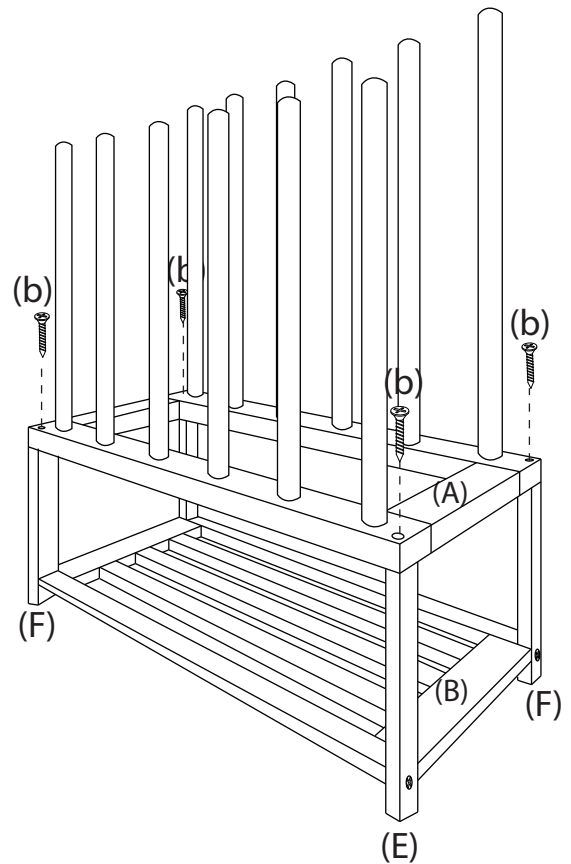

Put (A) onto top, place screw (b) through the larger holes, and line with the smaller holes on (E) & (F), then use a screwdriver to secure. Finally, tighten the rest screws in Step 2. Finished.

NOTE: MAKE SURE ALL THE SCREWS ARE TIGHTENED PROPERLY. IT IS VERY IMPORTANT!

DISCLAIMER: Install our shelf and shelving units according to instructions provided. We are not responsible for injury or damage resulting from incorrect installation or use. Our products are for use only as shelves units and are not intended for any other purposes.

* The emission of the chemicals listed in Prop 65 in this product has been tested to meet the standard of CARB ATCM.