

Installation & Assembly

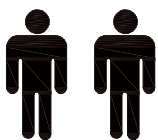

2 PERS.

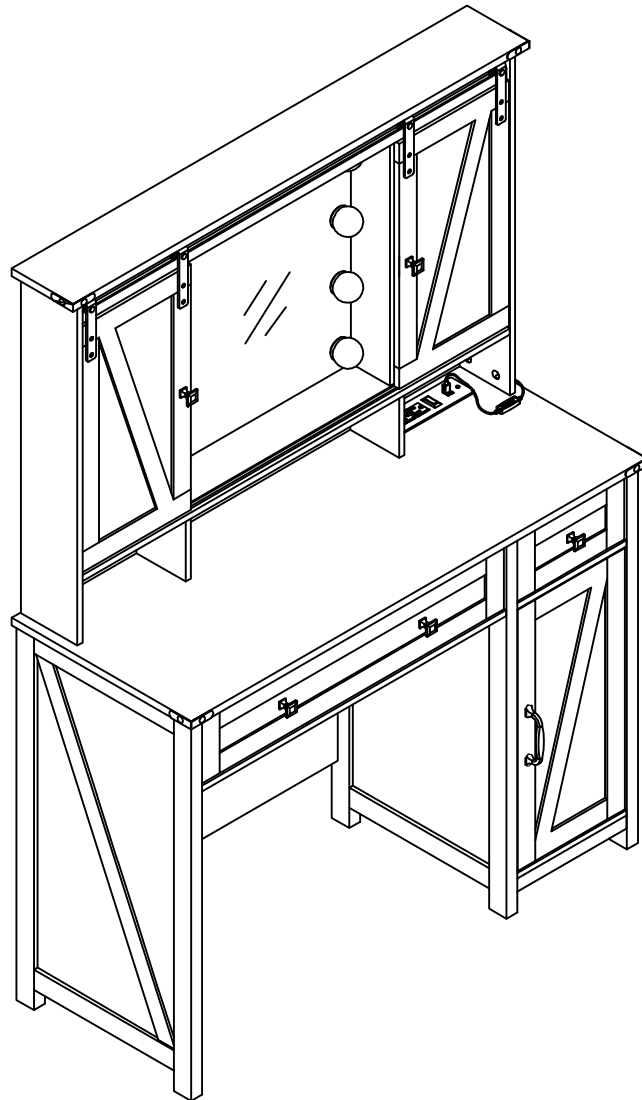

Tools required
(not included)

Version: 1.2

1. Matters needing attention

⚠ WARNING	
	<p>Children have died from furniture tipover. To reduce the risk of furniture tipover:</p> <ul style="list-style-type: none">-ALWAYS install Anti-tip device provided.-NEVER put a TV on this product.-NEVER allow children to stand, climb or hang on drawers, doors, or shelves.-NEVER open more than one drawer at a time.-Place heaviest items in the lowest drawers. <p><i>This is a permanent label. Do not remove!</i></p>
	

2. Matters needing attention

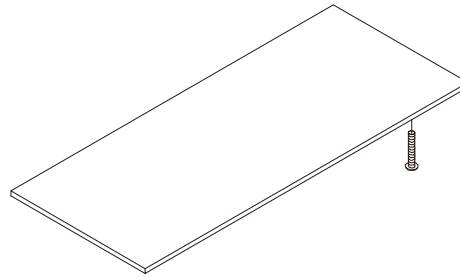

Be sure to use the proper screws to avoid damaging the parts

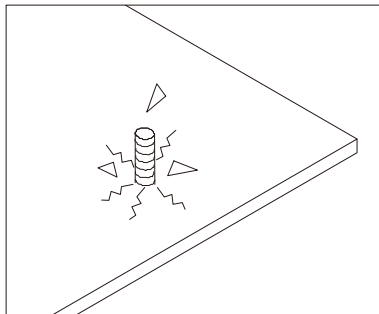

X

Wrong screws can cause the plank to crack

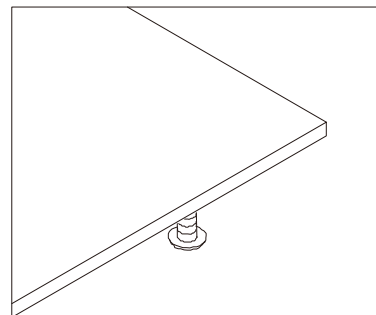

✓

The right screw is the right size

Cam Lock Fastening System

Insert the cam bolt into the hole first, then insert the cam lock and lock it.

1

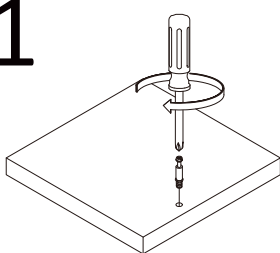

2

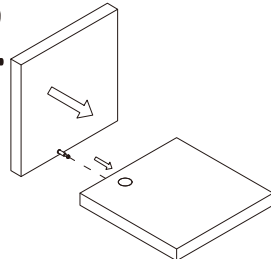

3

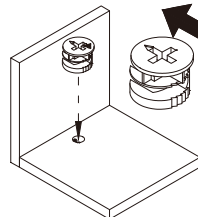

The opening must point toward the edge of the board

4

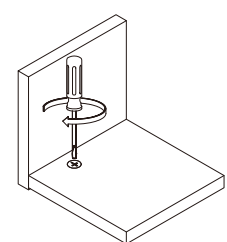

Installation Parts



CL

x2

L300mm(L)



CR

x2

L300mm(R)



DR

x2

L300mm(R)



DL

x2

L300mm(L)



E

x20+2

Ø 3.5x12mm



F

x76+3

Ø 6x35mm



G

x76+3

Ø15x10mm



H

x16+1

Ø4x30mm



I

x4



J

x20+2

Ø4x12mm



K

x12+1



L

x1

L=36mm



M

x2

Ø3x12mm

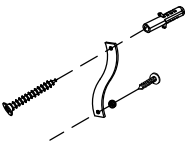

N

x2



O

x1



P

x1

Ø 3x12mm



Q

x3

Ø4x8mm



R

x59+3

Ø6x30mm



S

x6

Ø20x2mm



T

x16+2



U

x18+2

Ø3x14mm



V

x4

Ø4x16mm



W

x1

L=96mm



X

x5

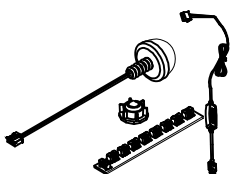

Y

x1



Z

x4



a

x4



b

x4

Ø6x25mm

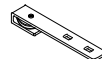

d

x4



e

x2

Ø 3x12mm

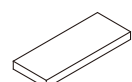

f

x6

Ø 30x10mm

Installation Parts

Mounting frame

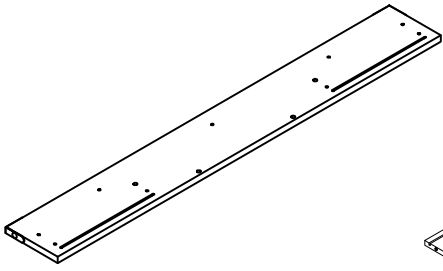

①

x1

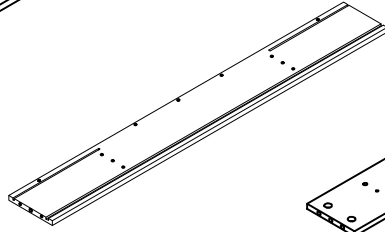

②

x1

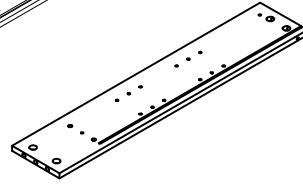

③

x1

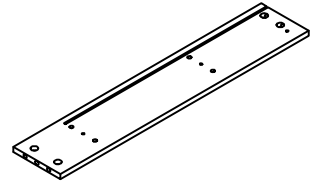

④

x1

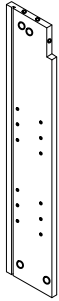

⑤

x1



⑥

x1

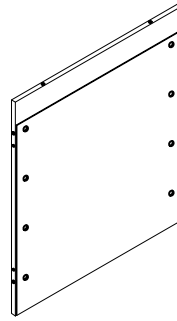

⑦

x1

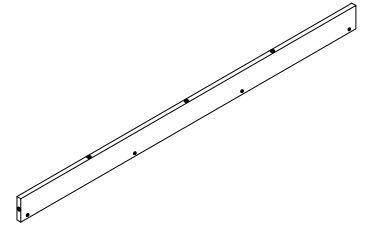

⑧

x1

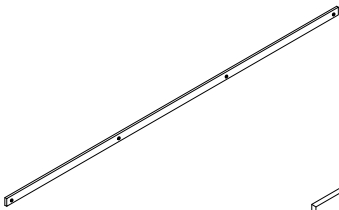

⑨

x1

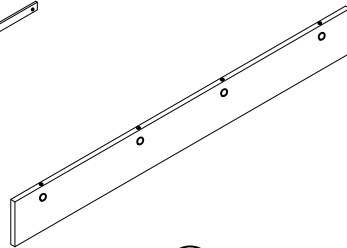

⑩

x1

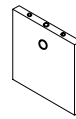

⑪

x2



⑫

x2

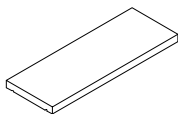

⑬

x2

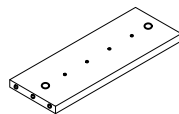

⑭

x1

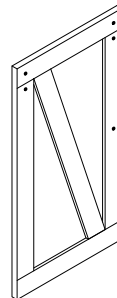

⑮

x1

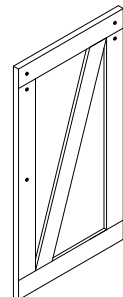

⑯

x1

Mounting frame

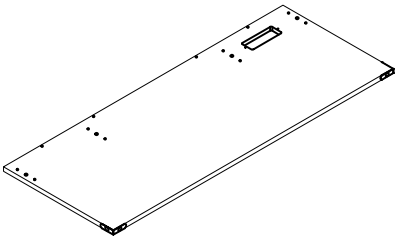

17
x1

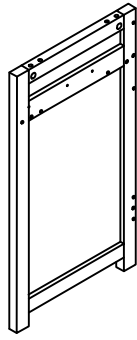

18
x1

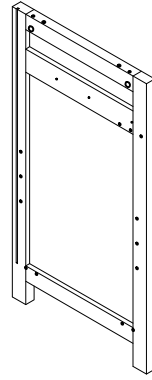

19
x1

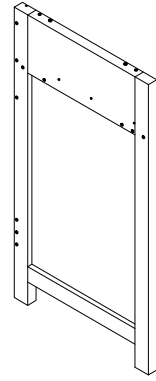

20
x1

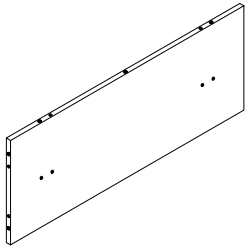

21
x1

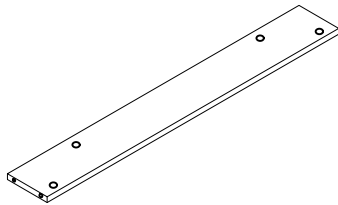

22
x1

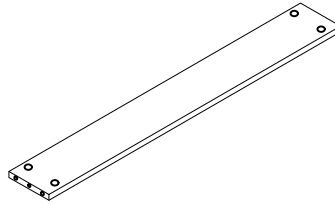

23
x2

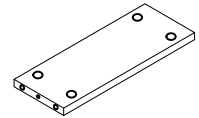

24
x1

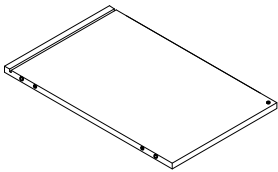

25
x1

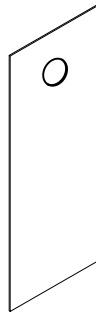

26
x1

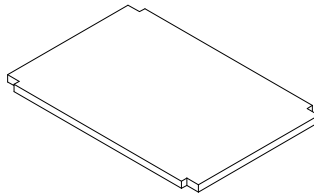

27
x1

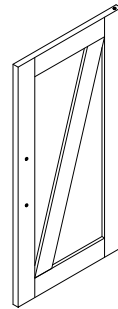

28
x1

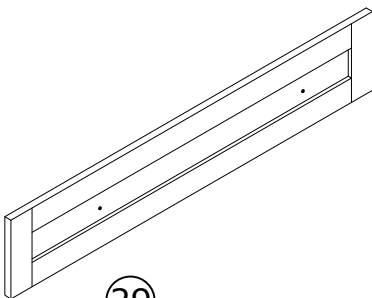

29
x1

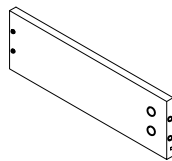

30
x2

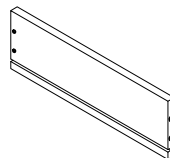

31
x2

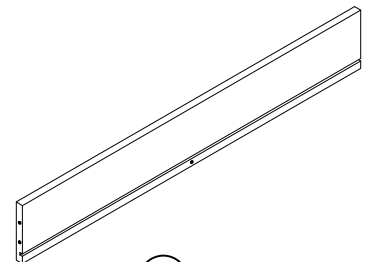

32
x1

Mounting frame

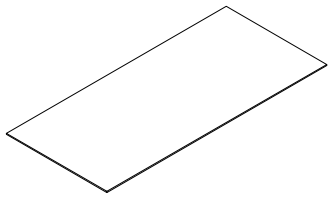

33

x1

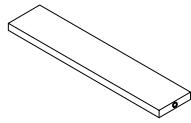

34

x1

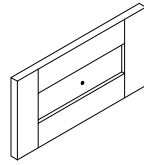

35

x1

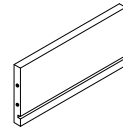

36

x1

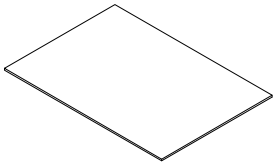

37

x1

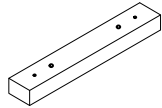

38

x1

Please use each screw in strict accordance with the instructions.

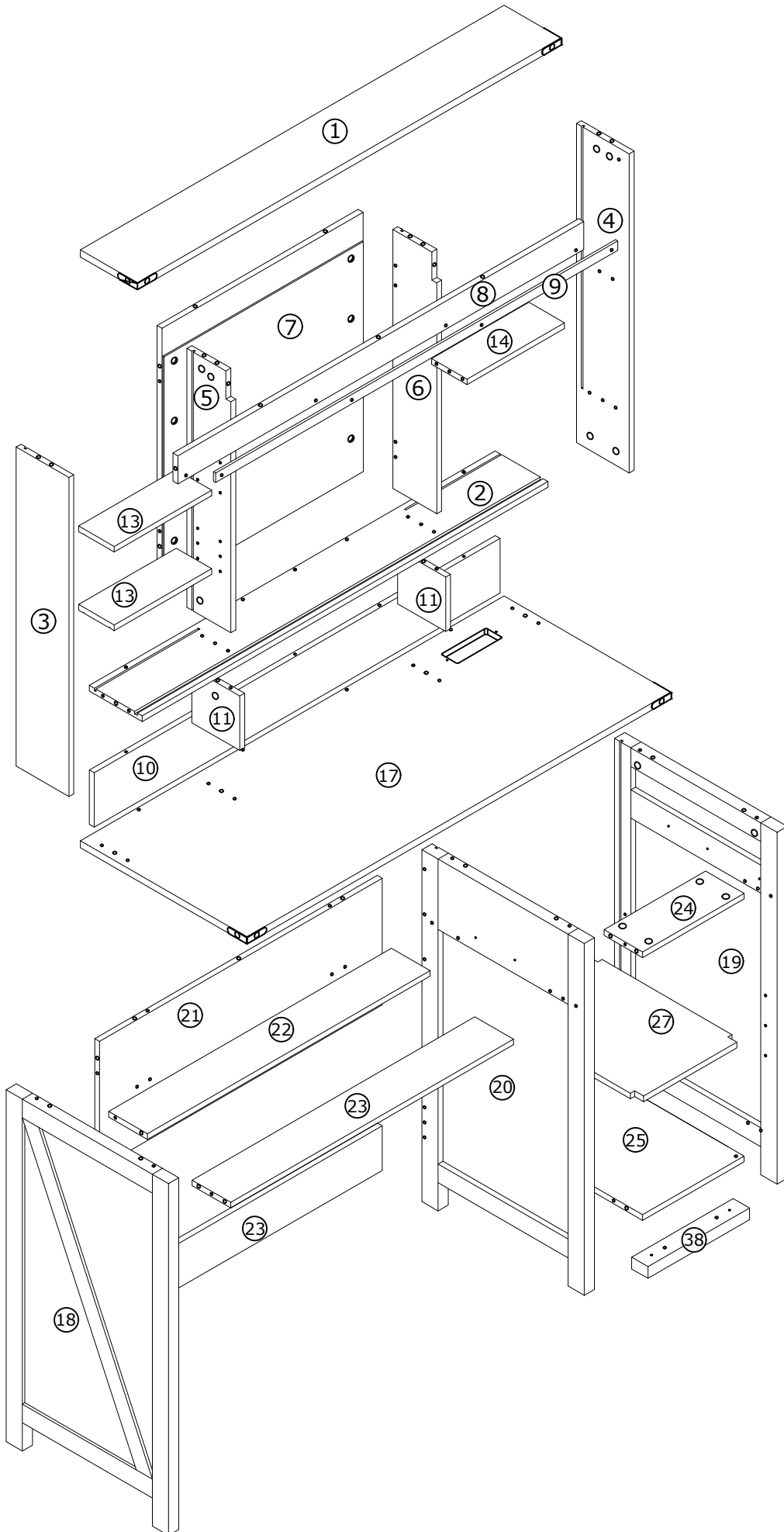

Please use each screw in strict accordance with the instructions.

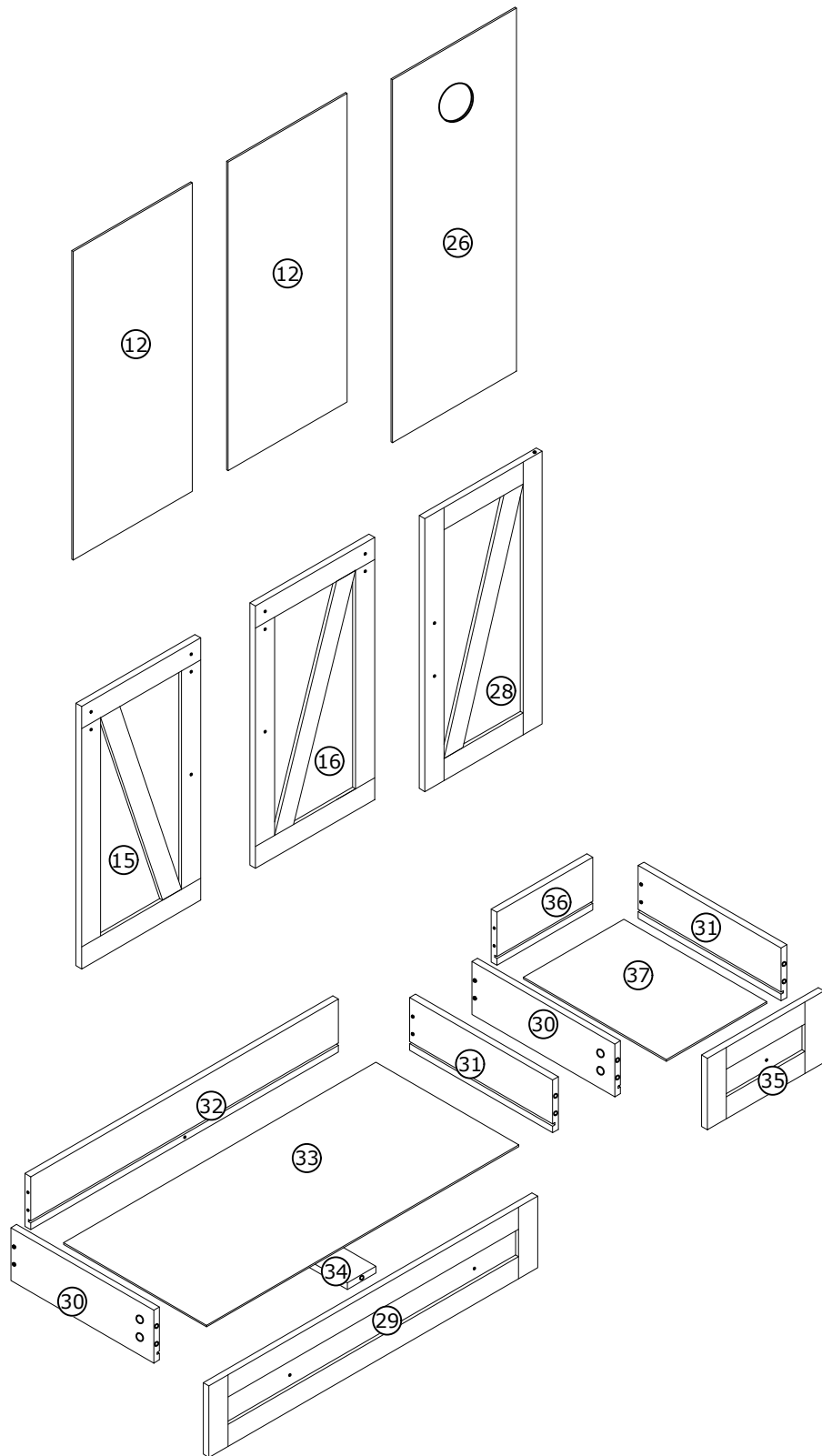

1

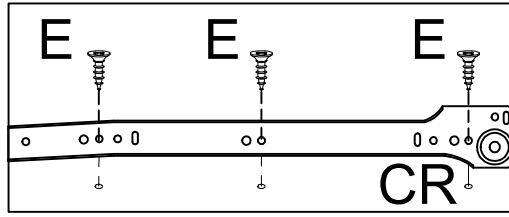
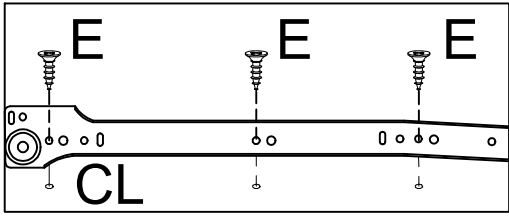

CL
L300mm(L) X1

CR
L300mm(R) X1

E
Ø3.5×12mmX6

f
Ø30×10mm X4

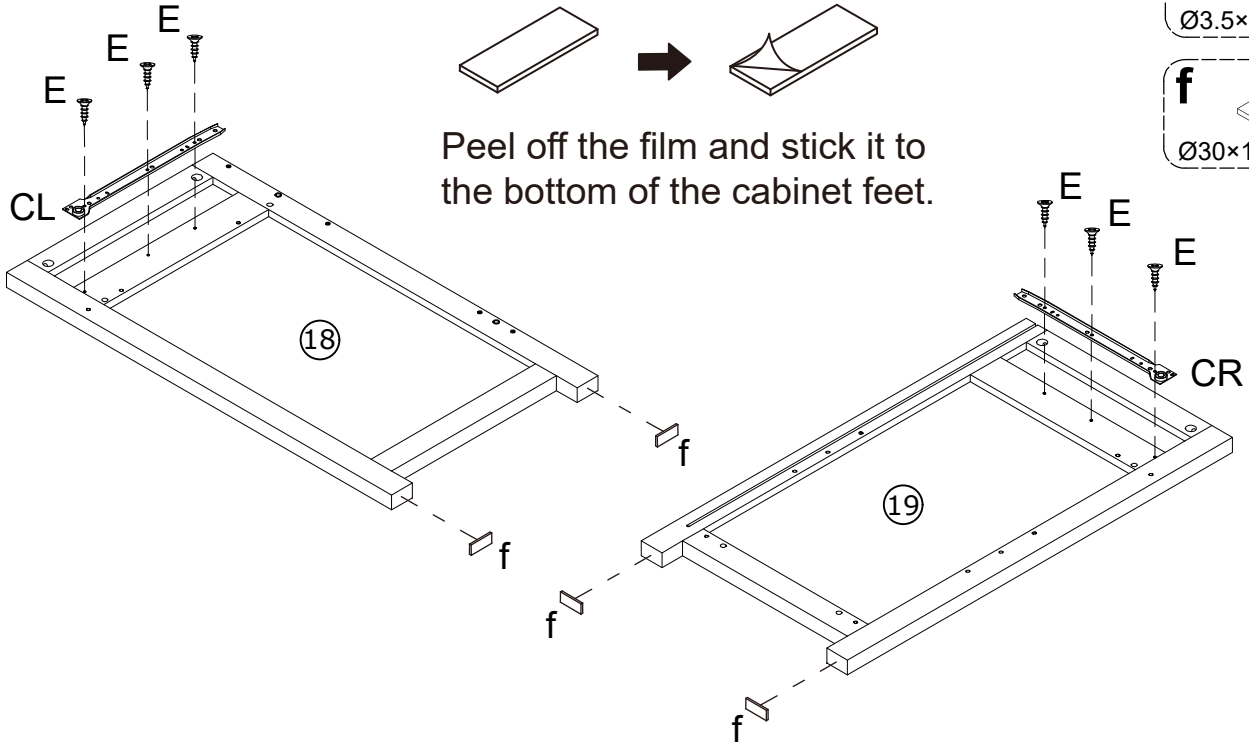

2

F
Ø6×35mm X11

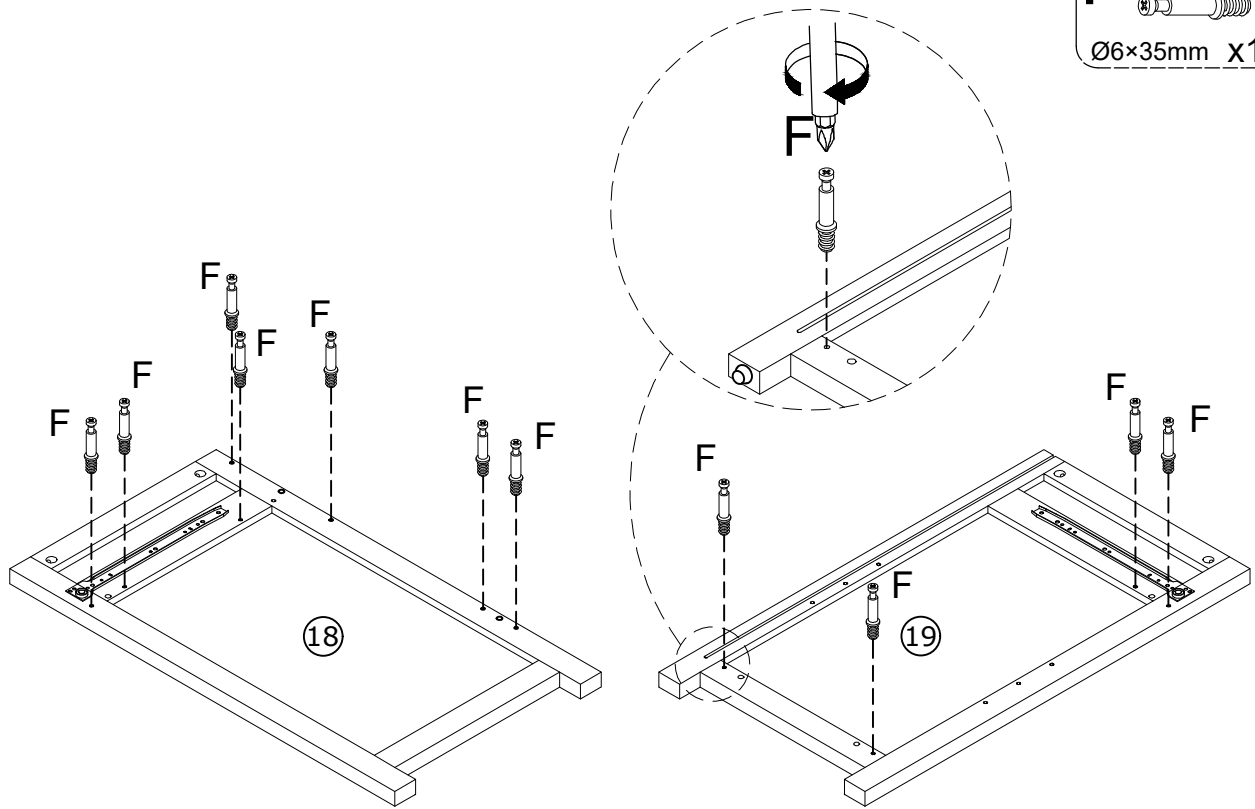

3

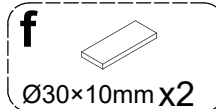
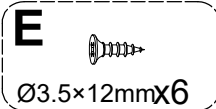
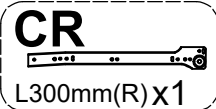
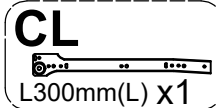
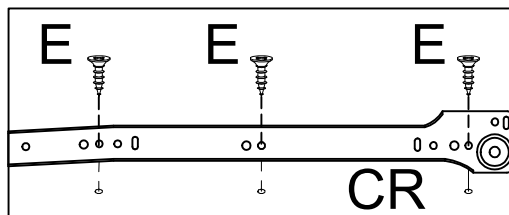
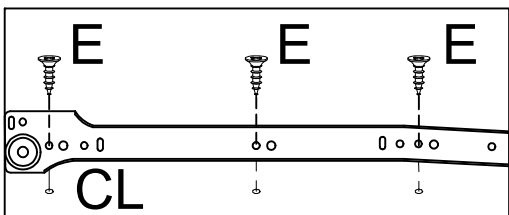

Peel off the film and stick it to the bottom of the cabinet feet.

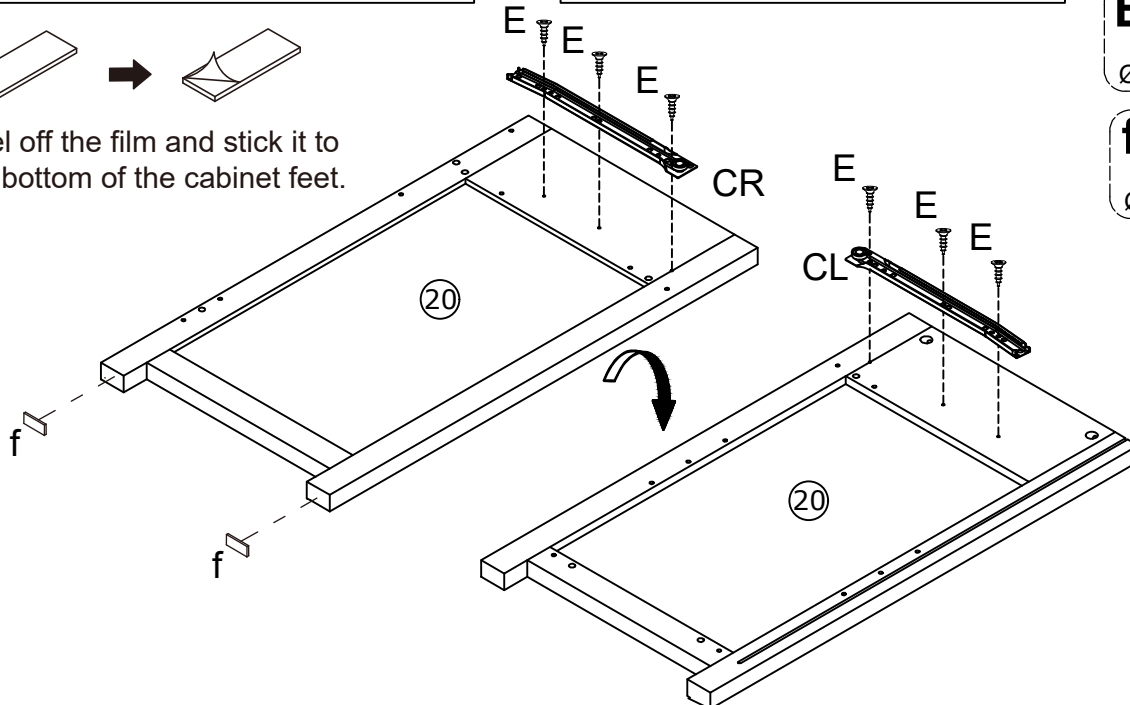

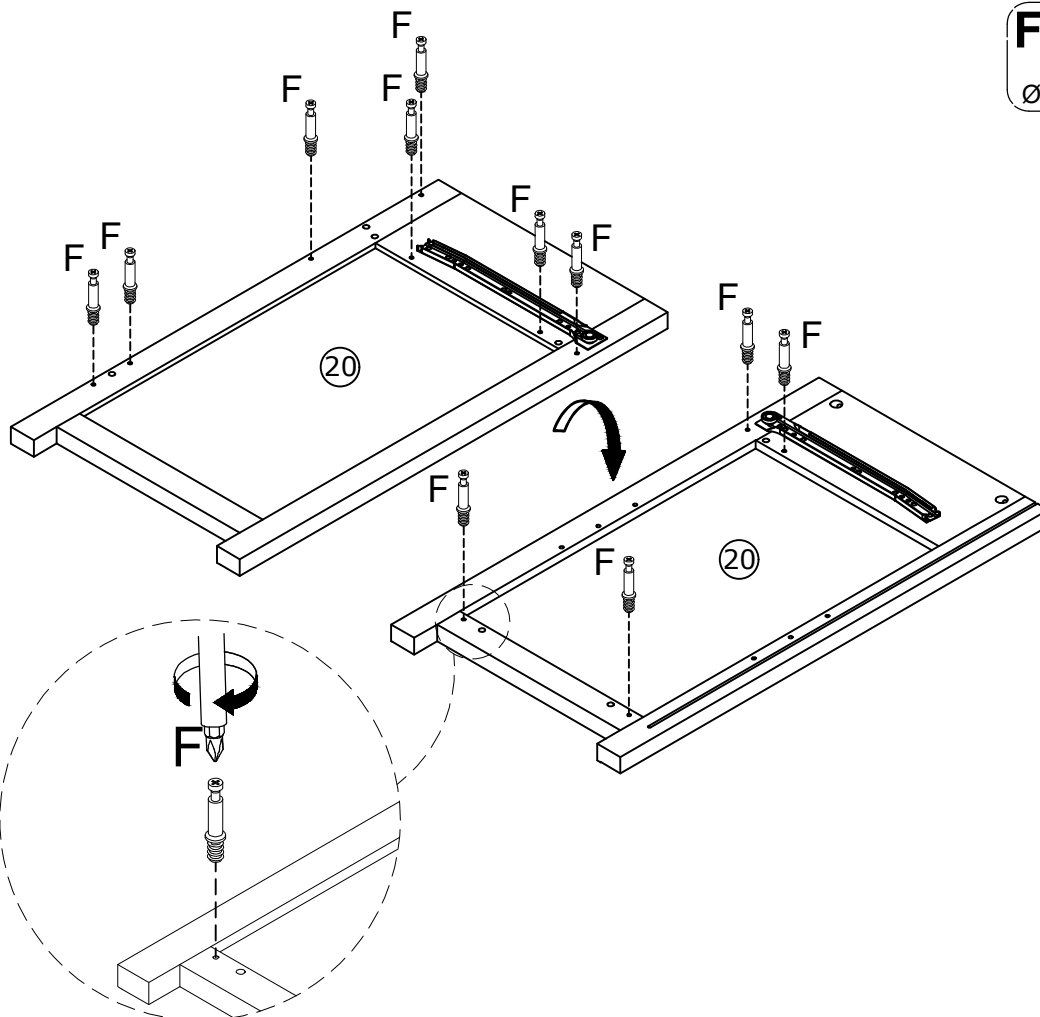
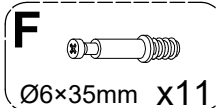

4



5

G 
Ø15×10mm x2

H 
Ø4×30mm x2

R 
Ø6×30mm x4

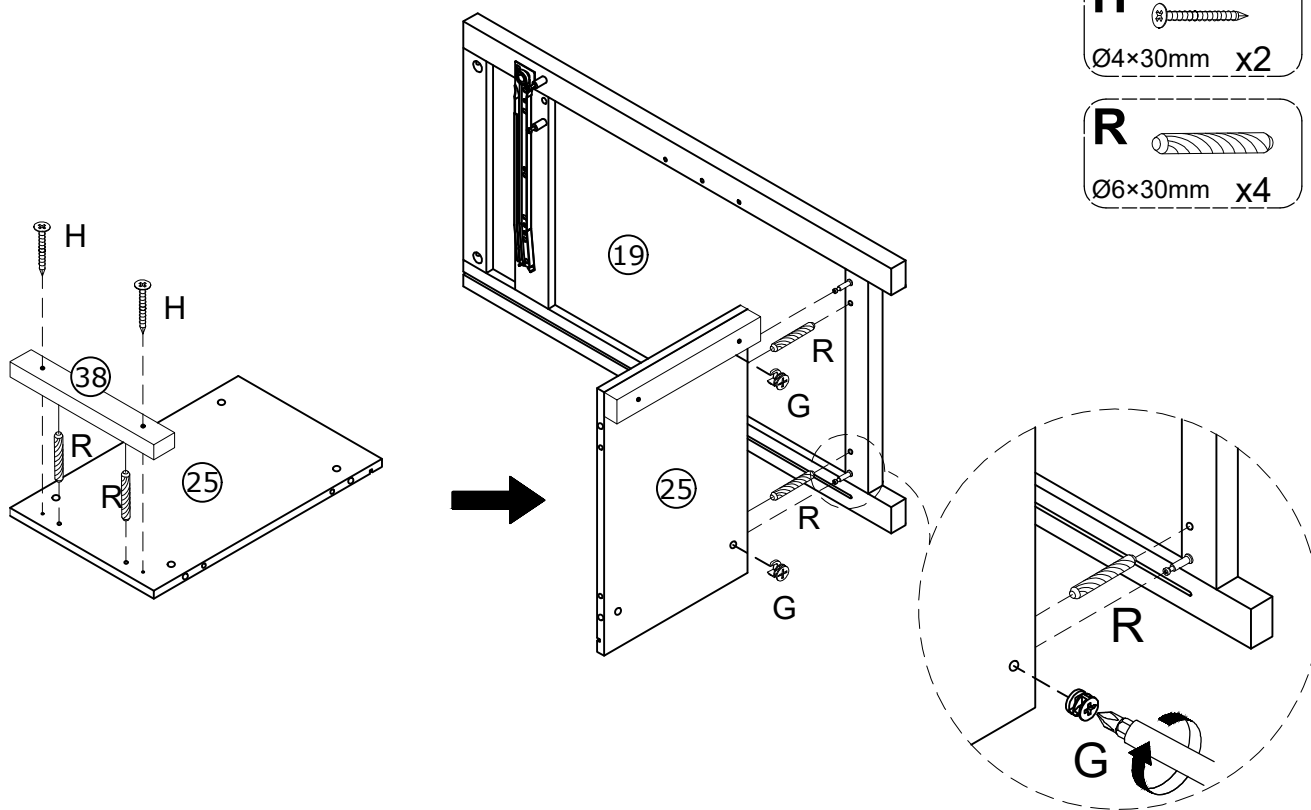

6

L 
L=36mm x1

U 
Ø3×14mm x2

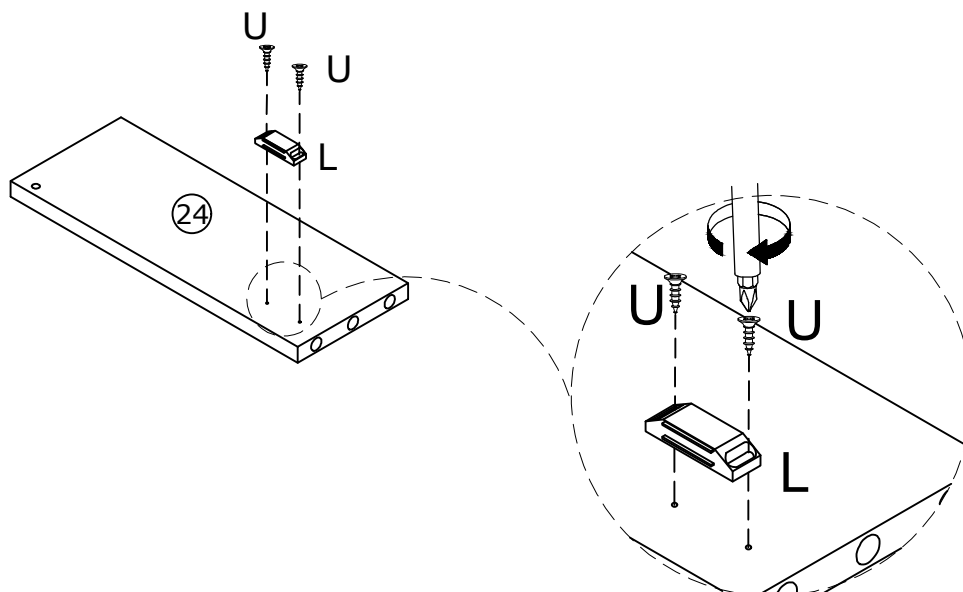

7

G 
Ø15×10mm x2

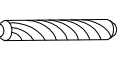
R 
Ø6×30mm x1

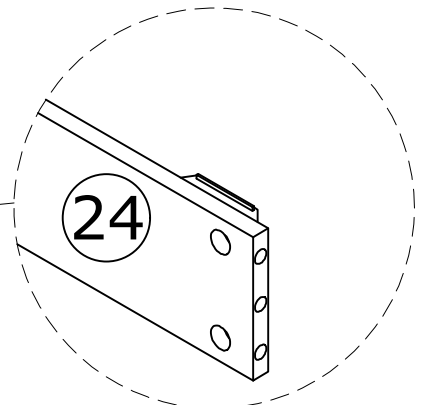
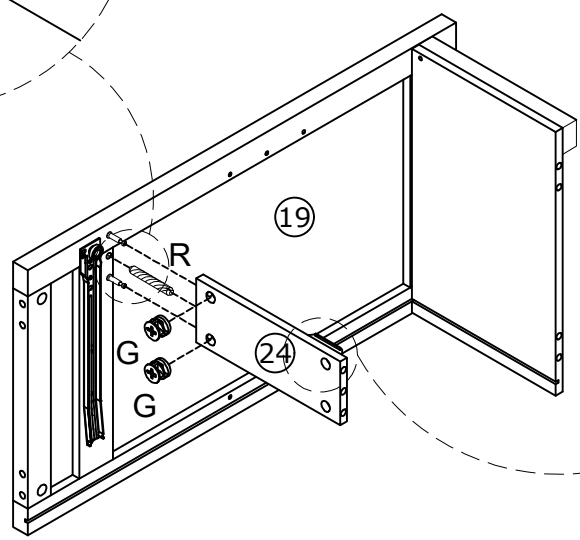
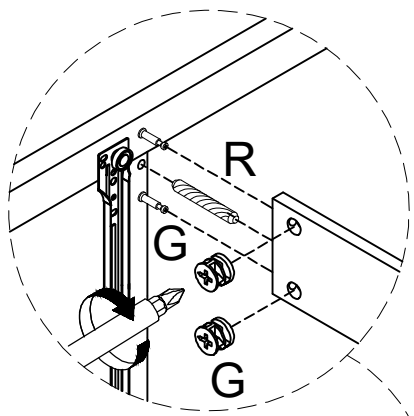

8

G 
Ø15×10mm x4

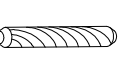
R 
Ø6×30mm x3

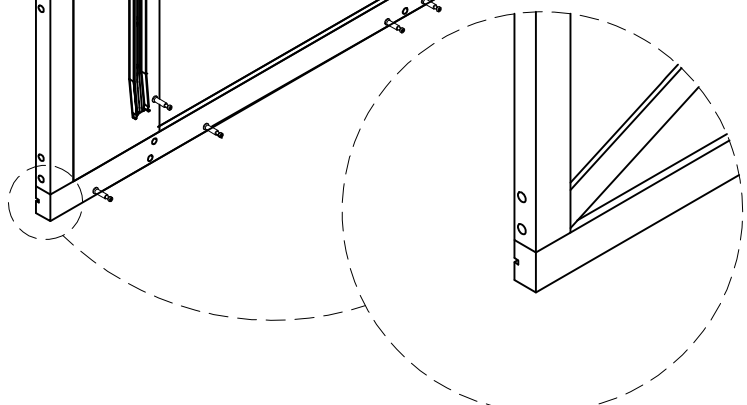
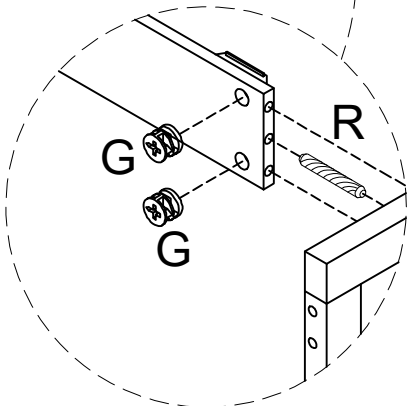
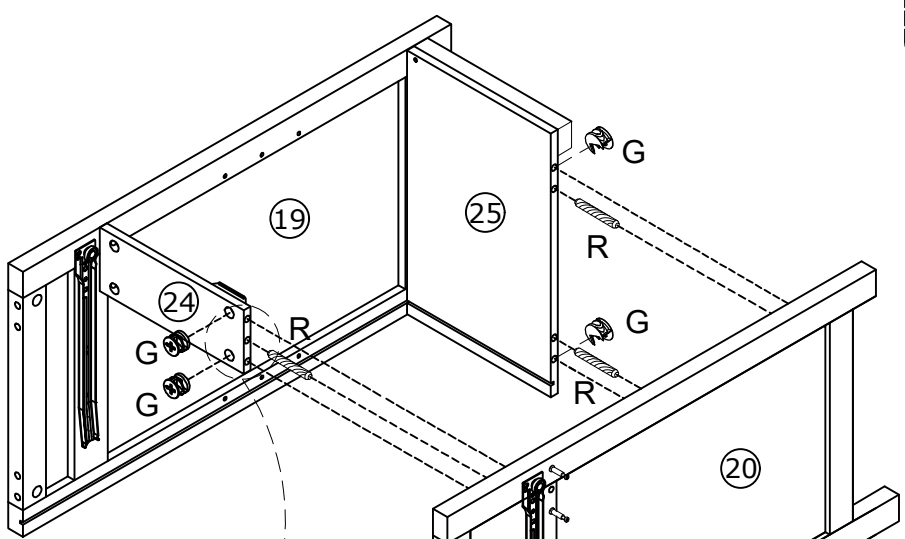

9

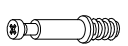
F 
Ø6×35mm x2

G 
Ø15×10mm x2

R 
Ø6×30mm x2

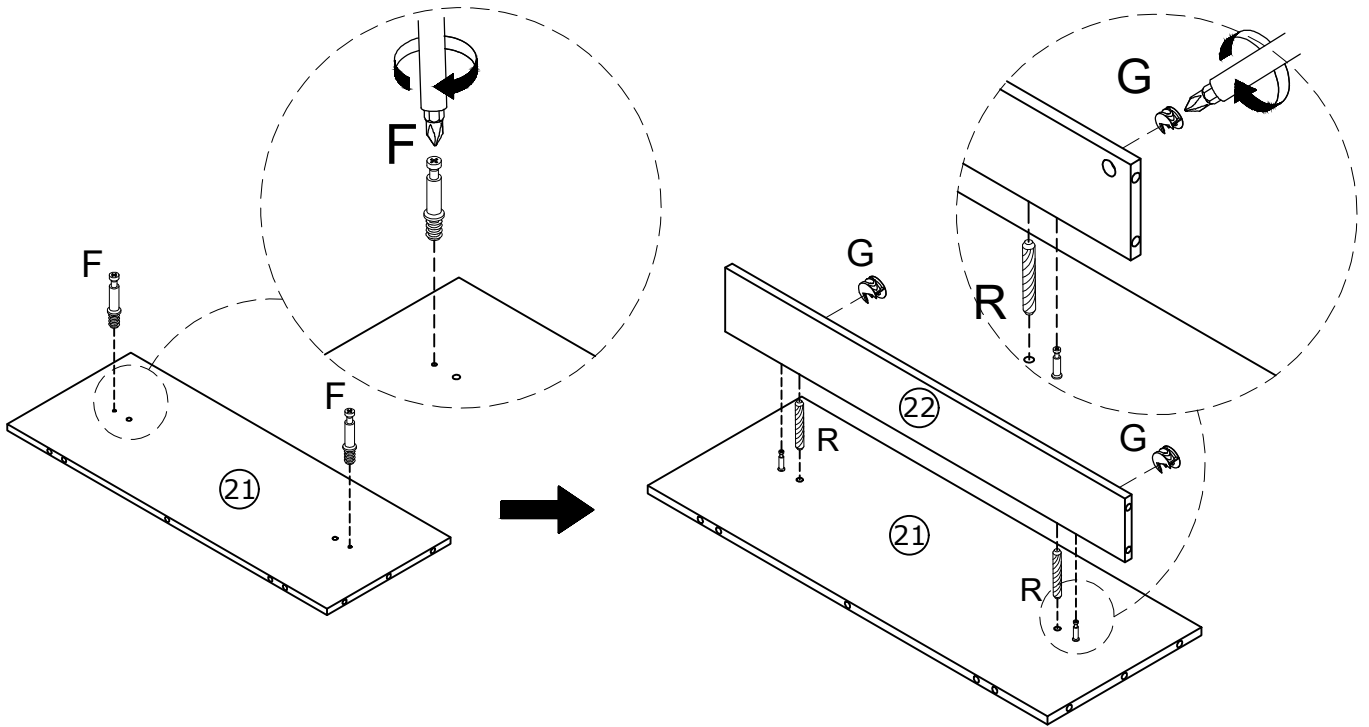

10

G 
Ø15×10mm x3

R 
Ø6×30mm x4

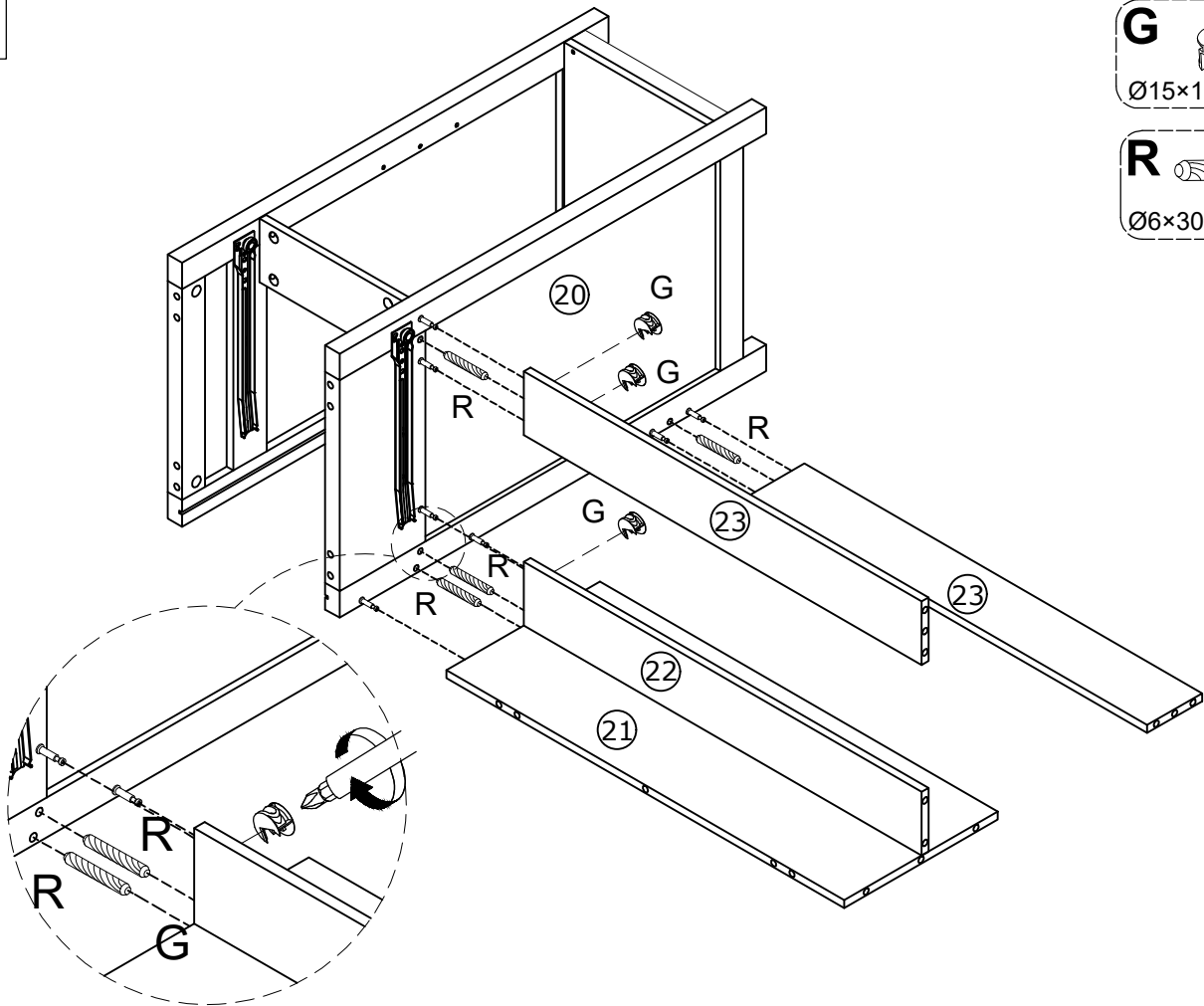

11

G 
Ø15×10mm x3

R 
Ø6×30mm x4

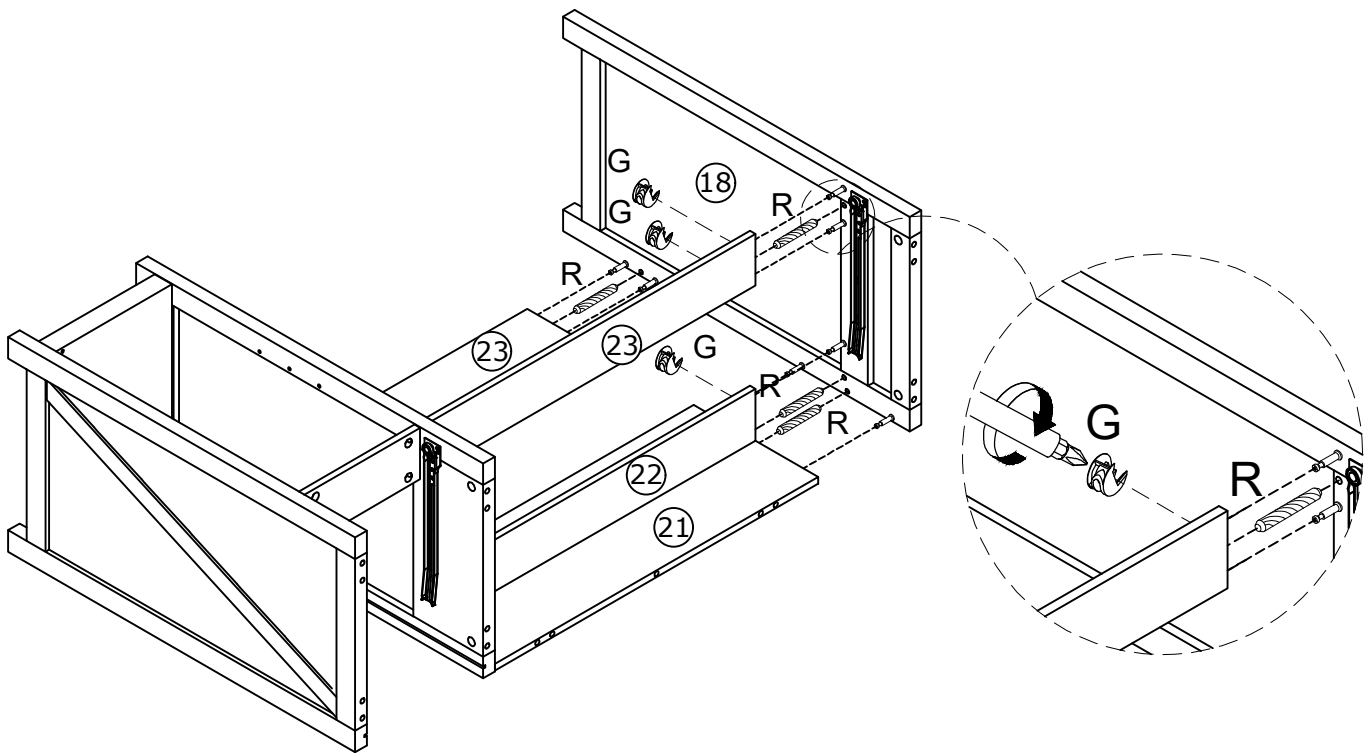

12

G 
Ø15×10mm x8

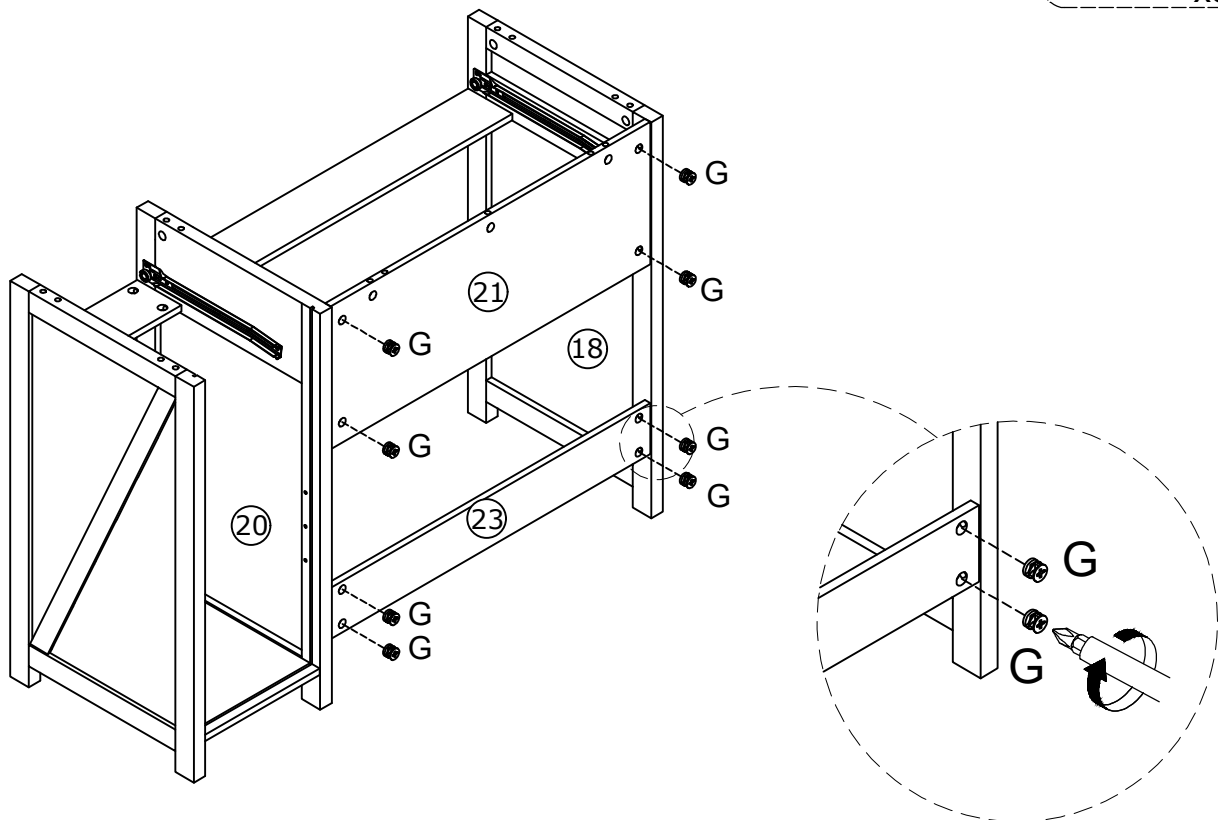

13

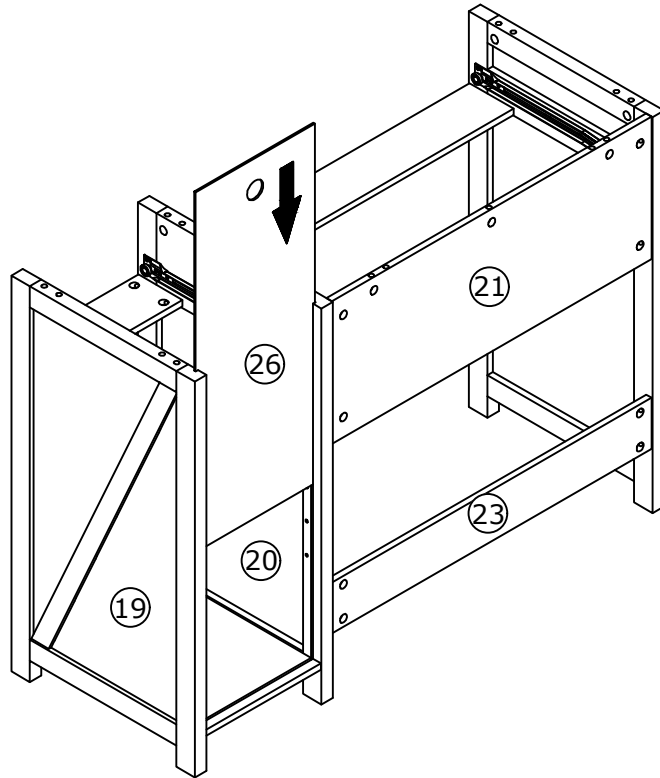

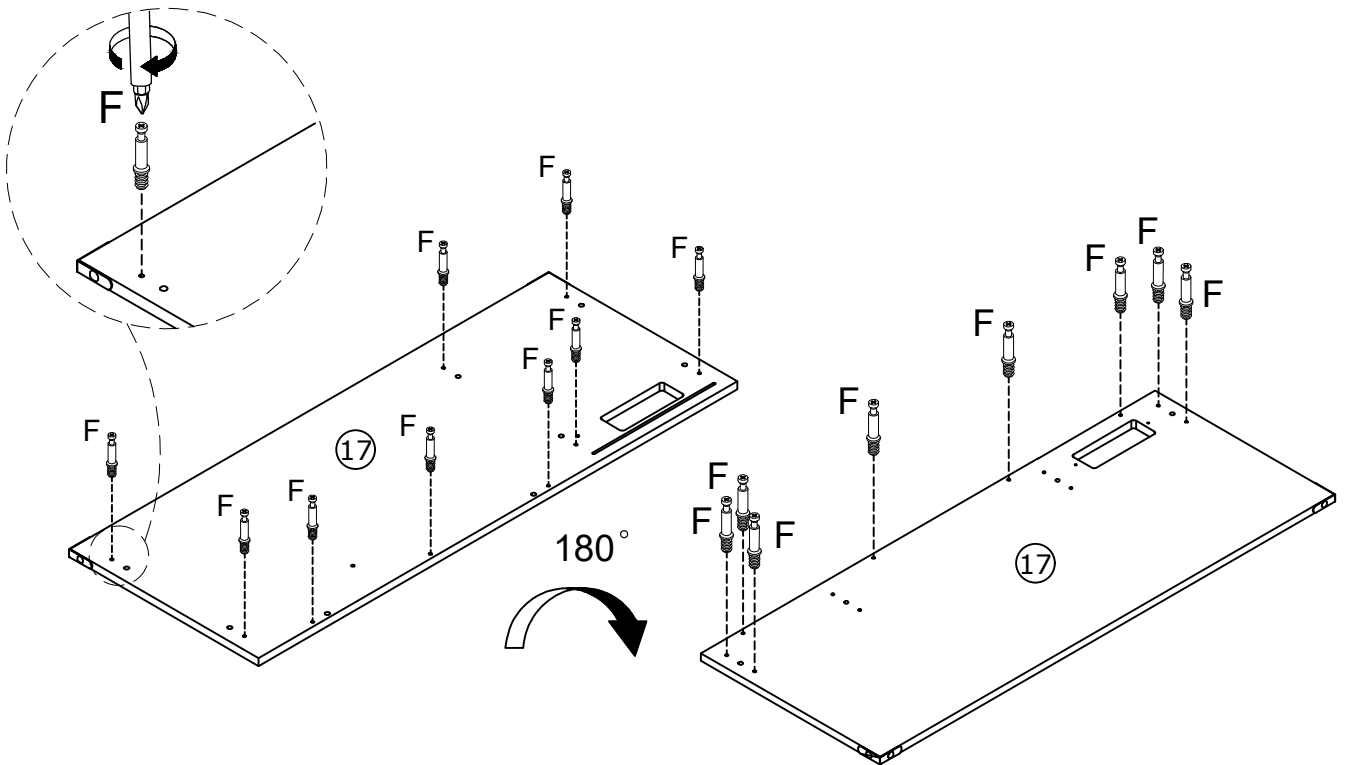
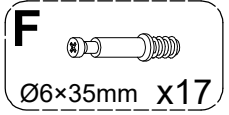

14

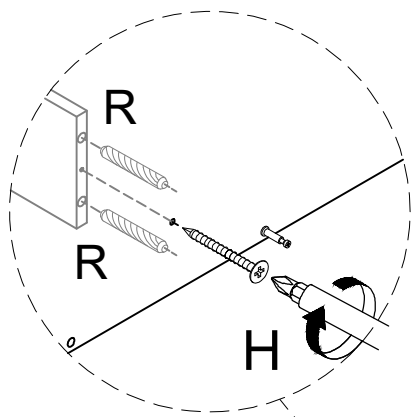

15



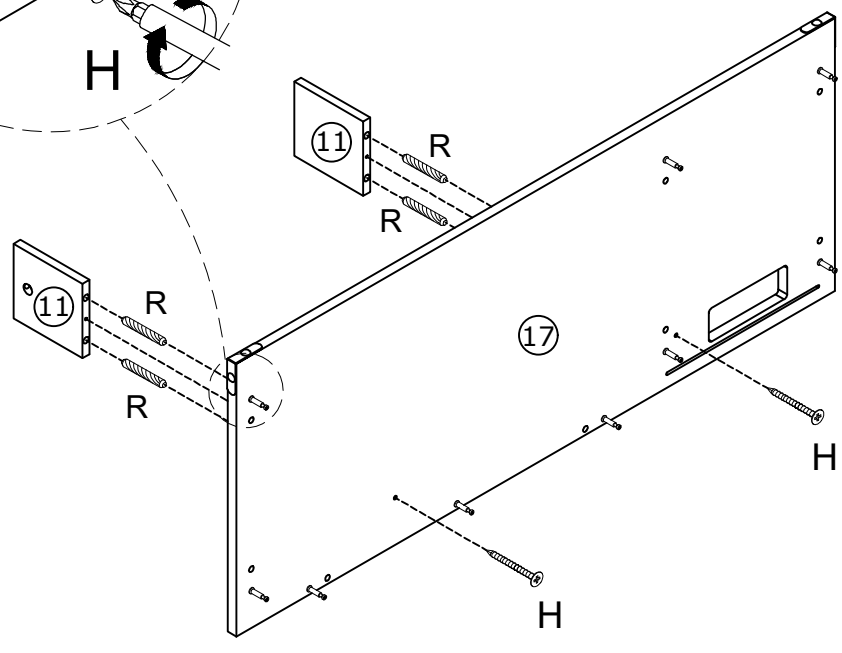

H 
 Ø4×30mm x2

R 
 Ø6×30mm x4



16

G 
 Ø15×10mm x9

R 
 Ø6×30mm x8

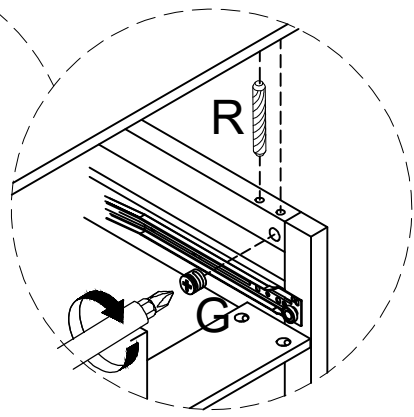
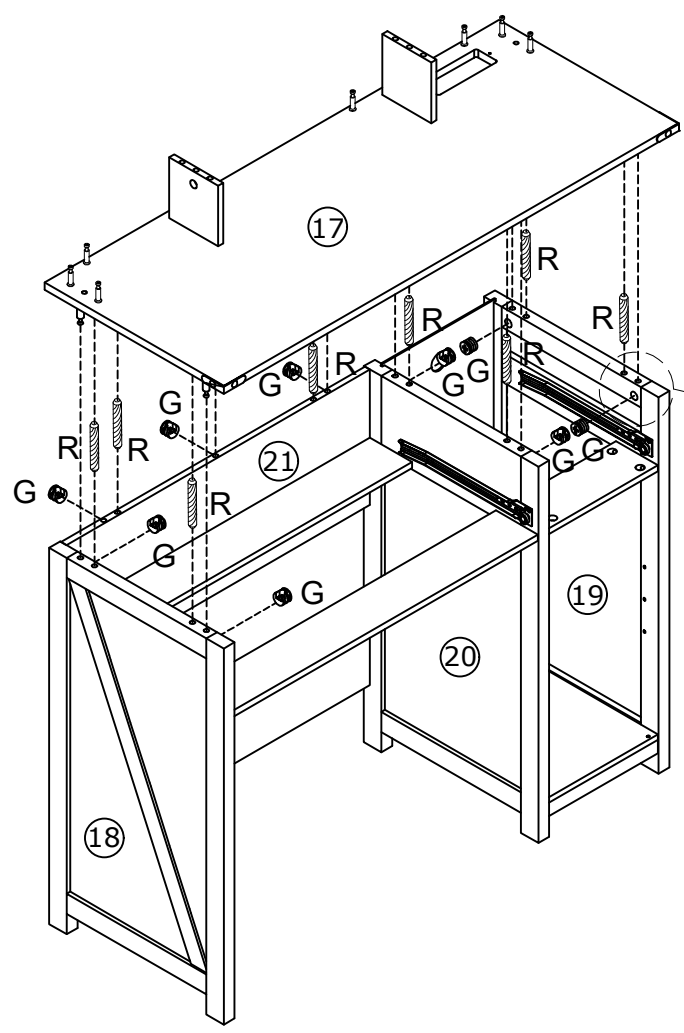

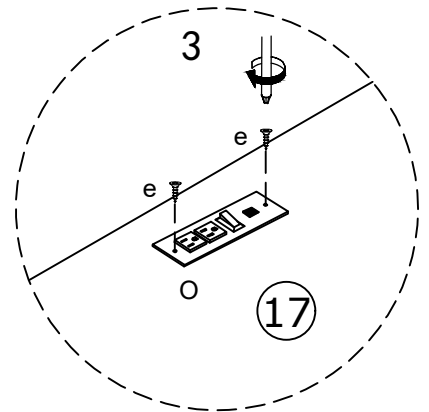
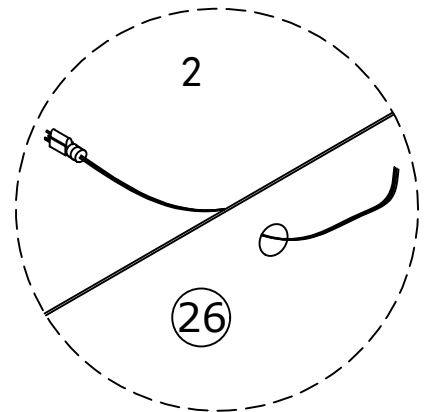
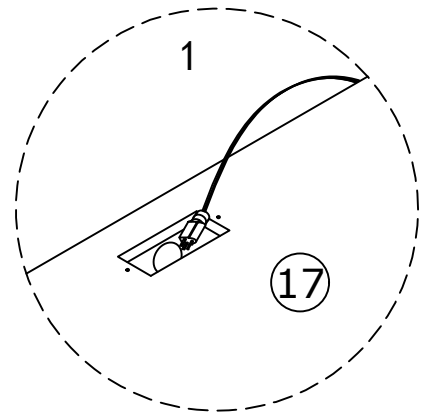
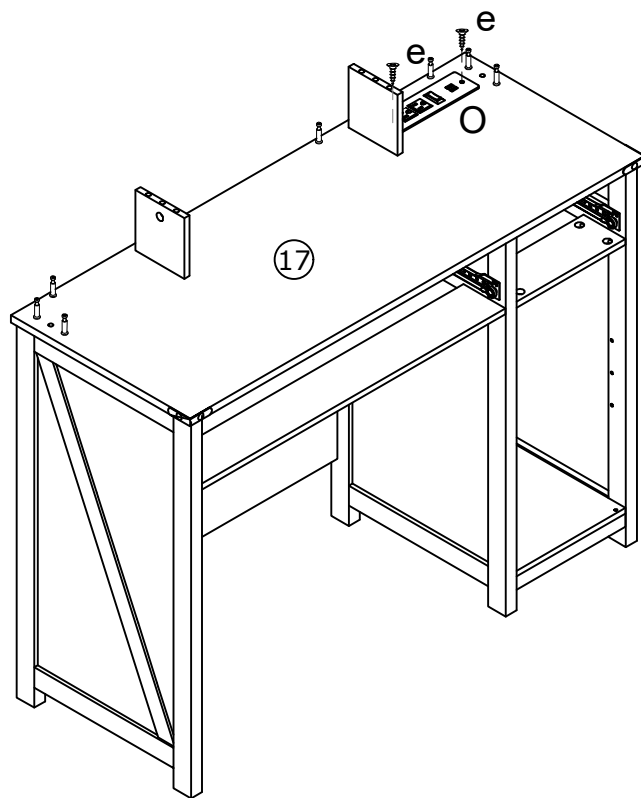
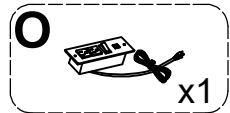
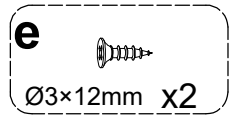

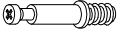

18

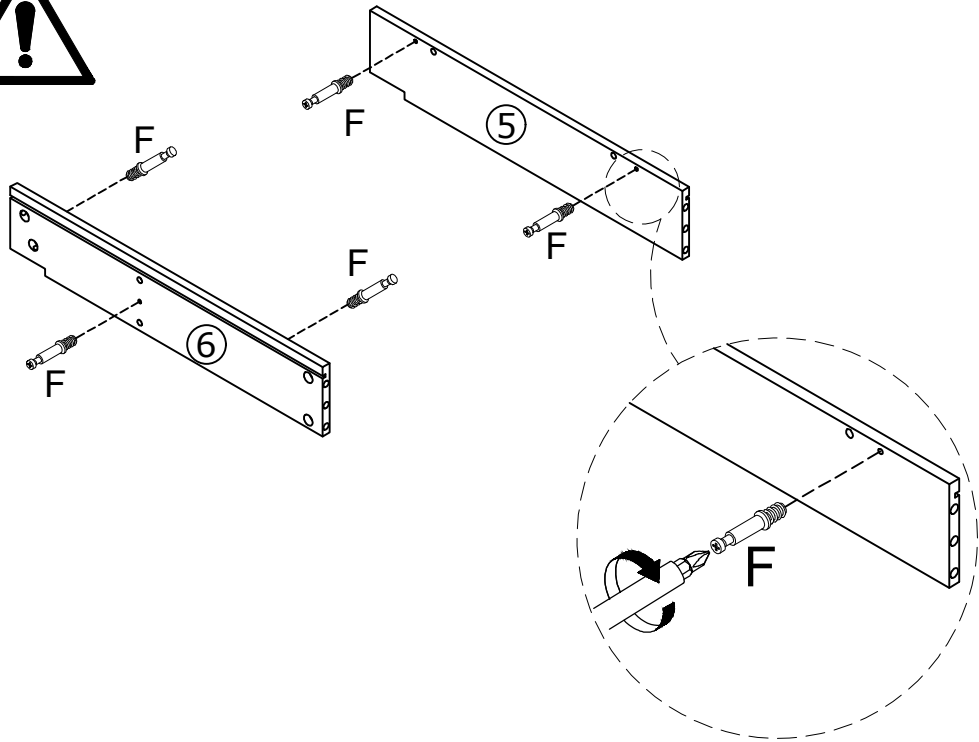
F 
Ø6×35mm x5



19

G 
Ø15×10mm x4

R 
Ø6×30mm x4

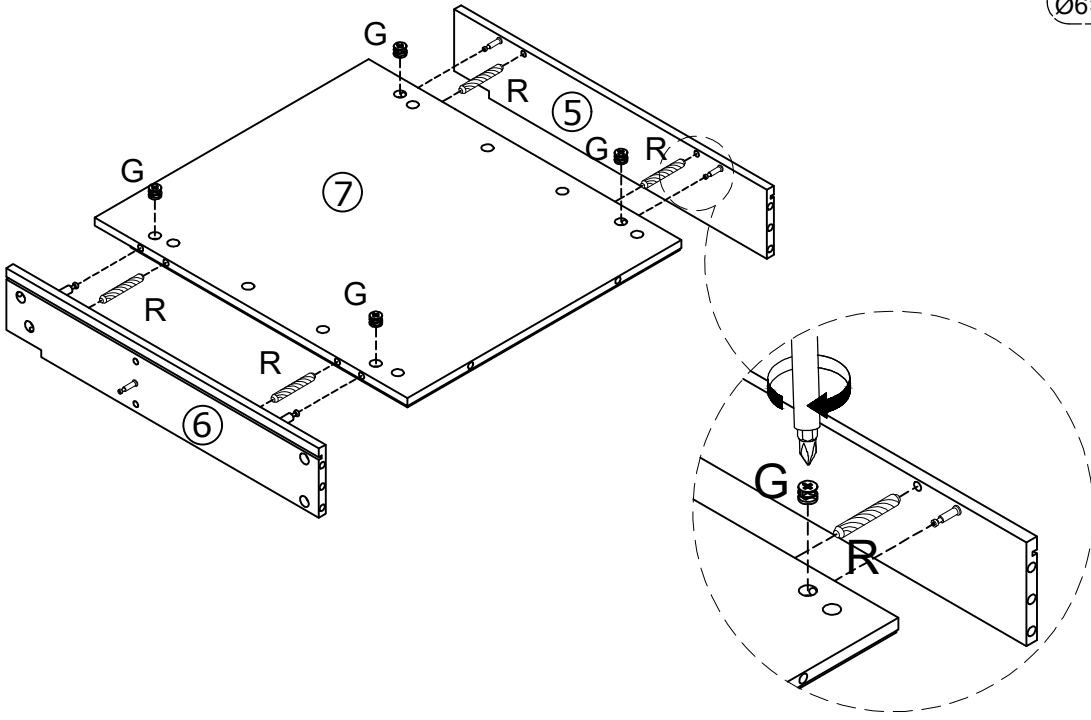

20

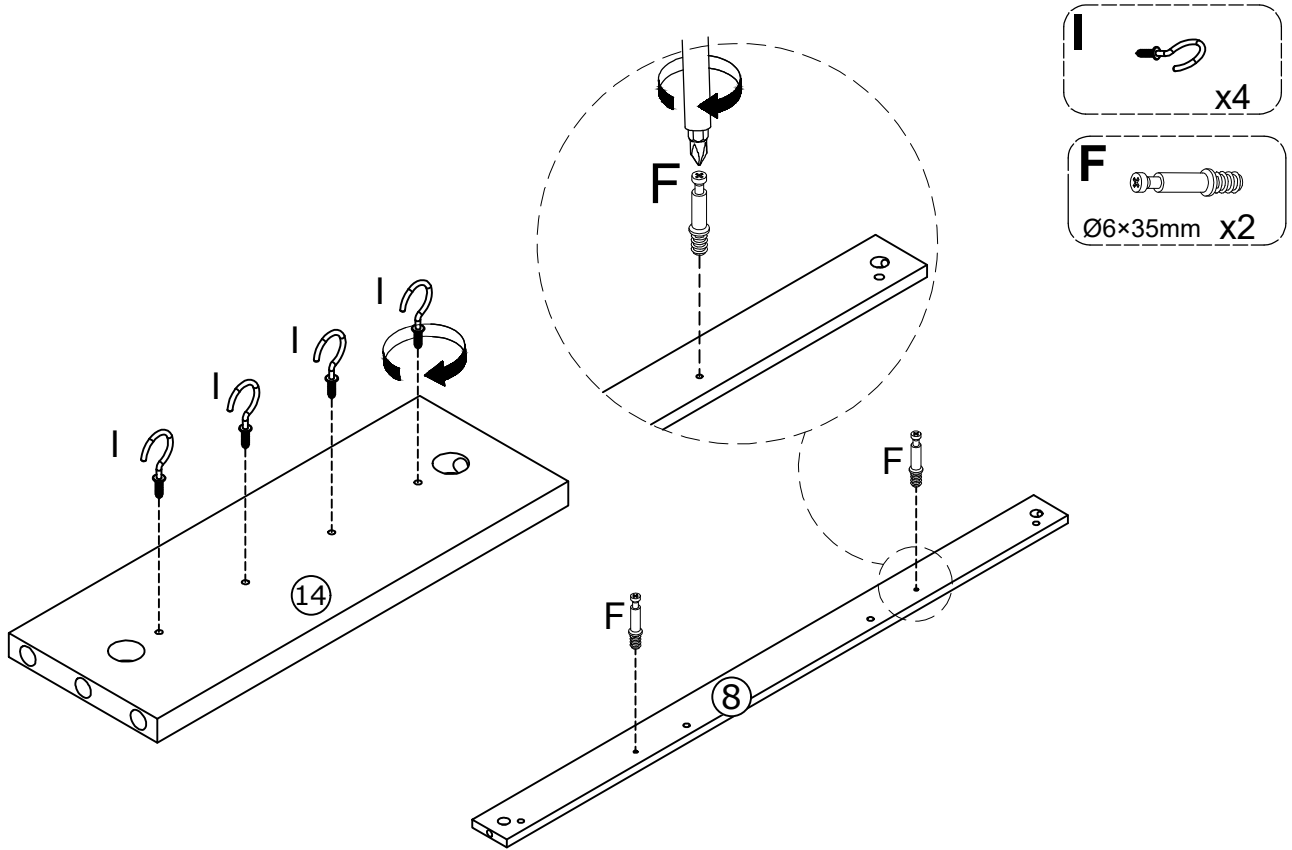

21

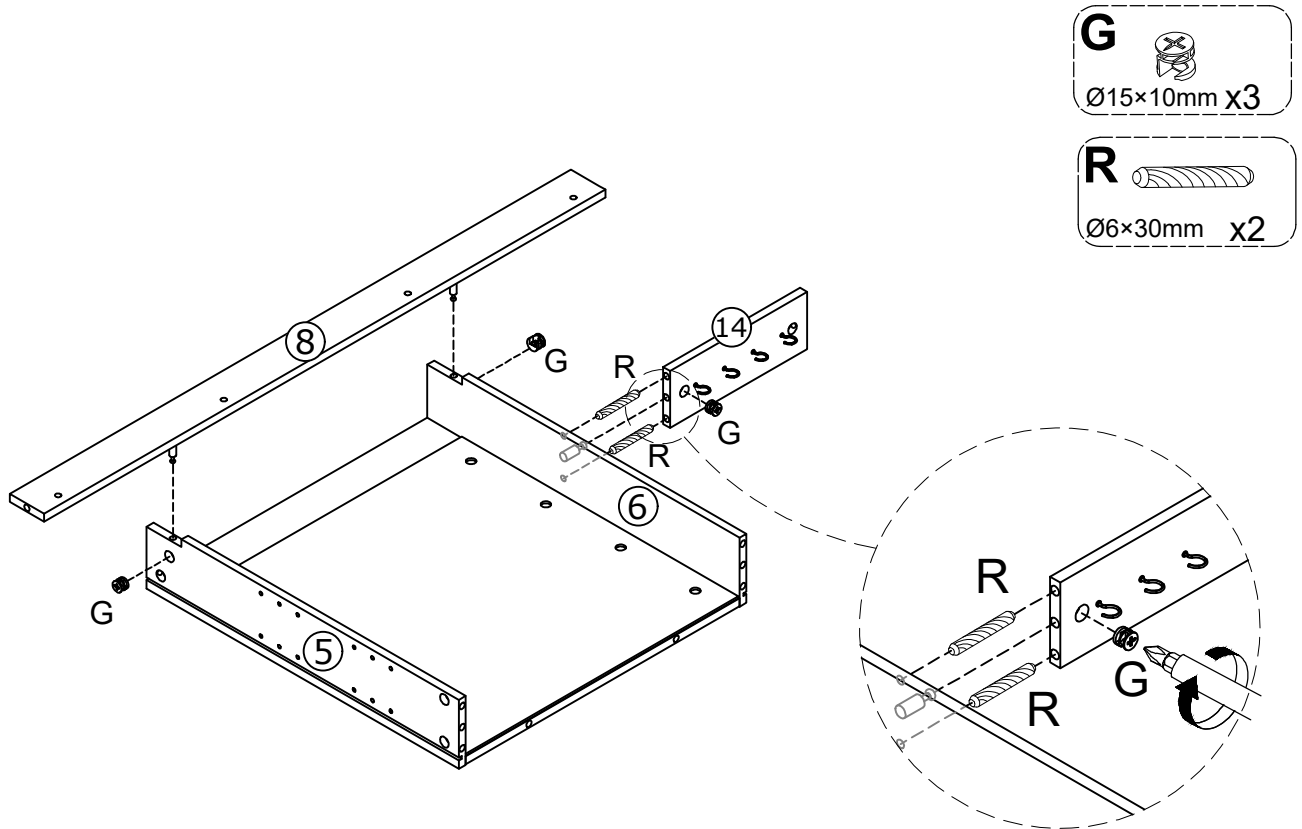

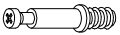

22

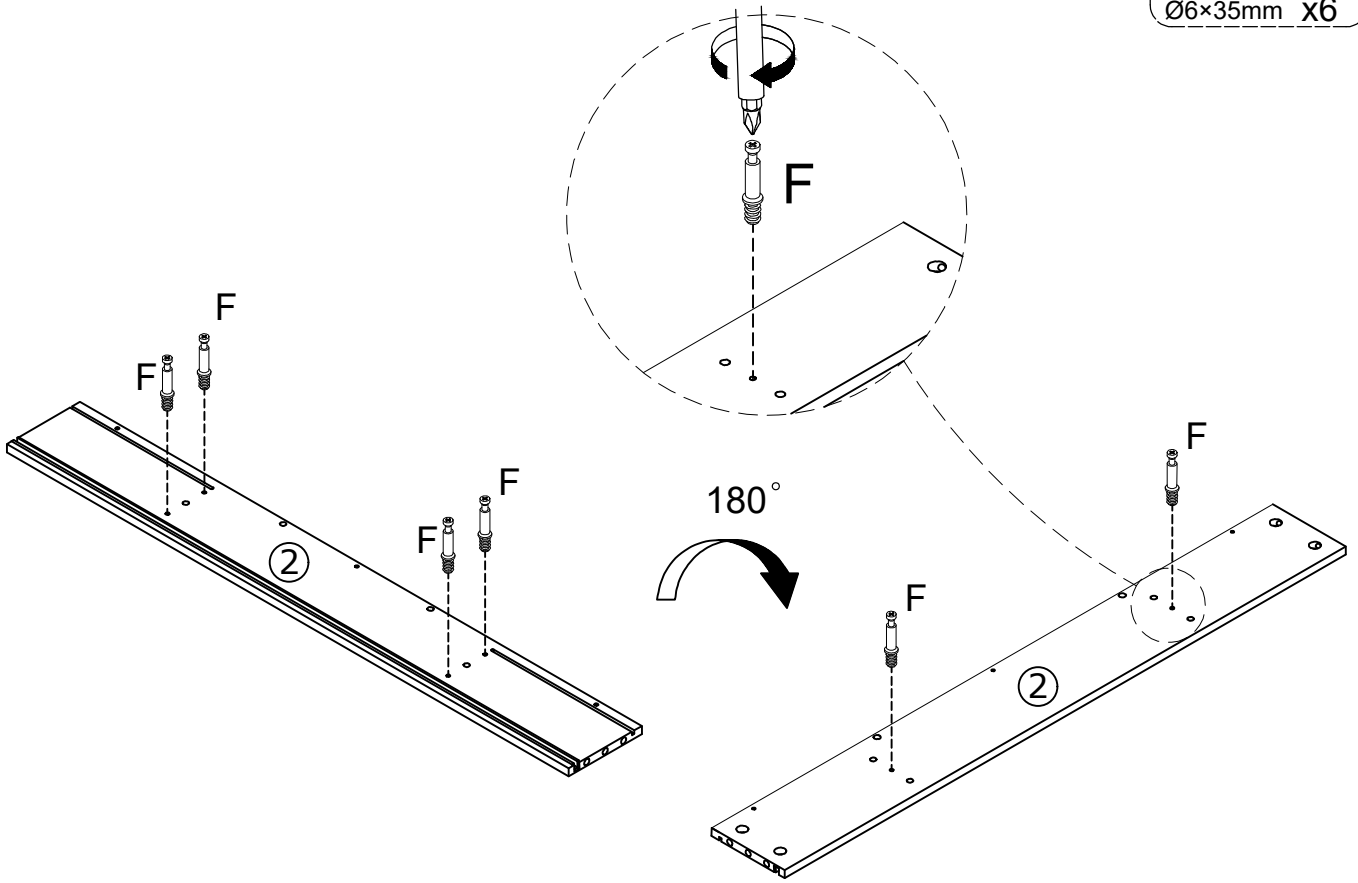
F 
Ø6×35mm x6

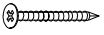

23

H 
Ø4×30mm x3

R 
Ø6×30mm x2

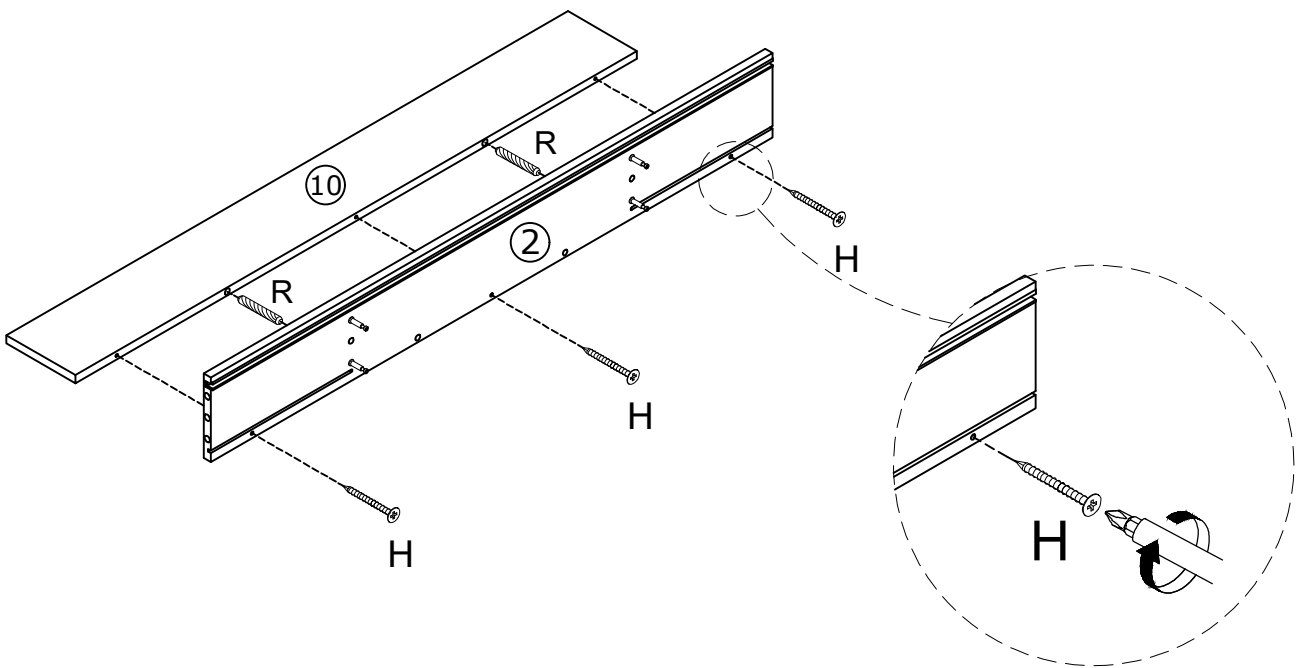

24

G 
Ø15×10mm x4

R 
Ø6×30mm x4

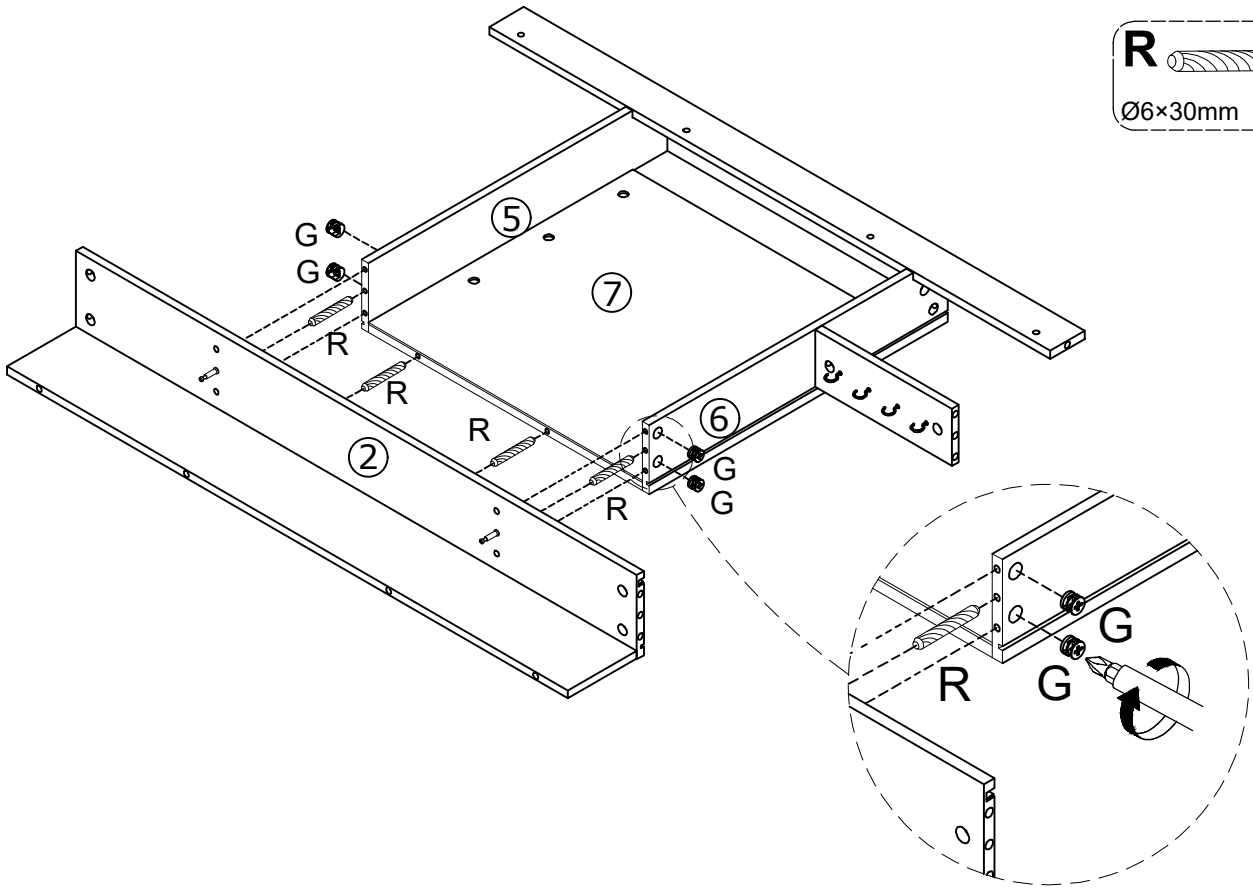

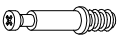

25

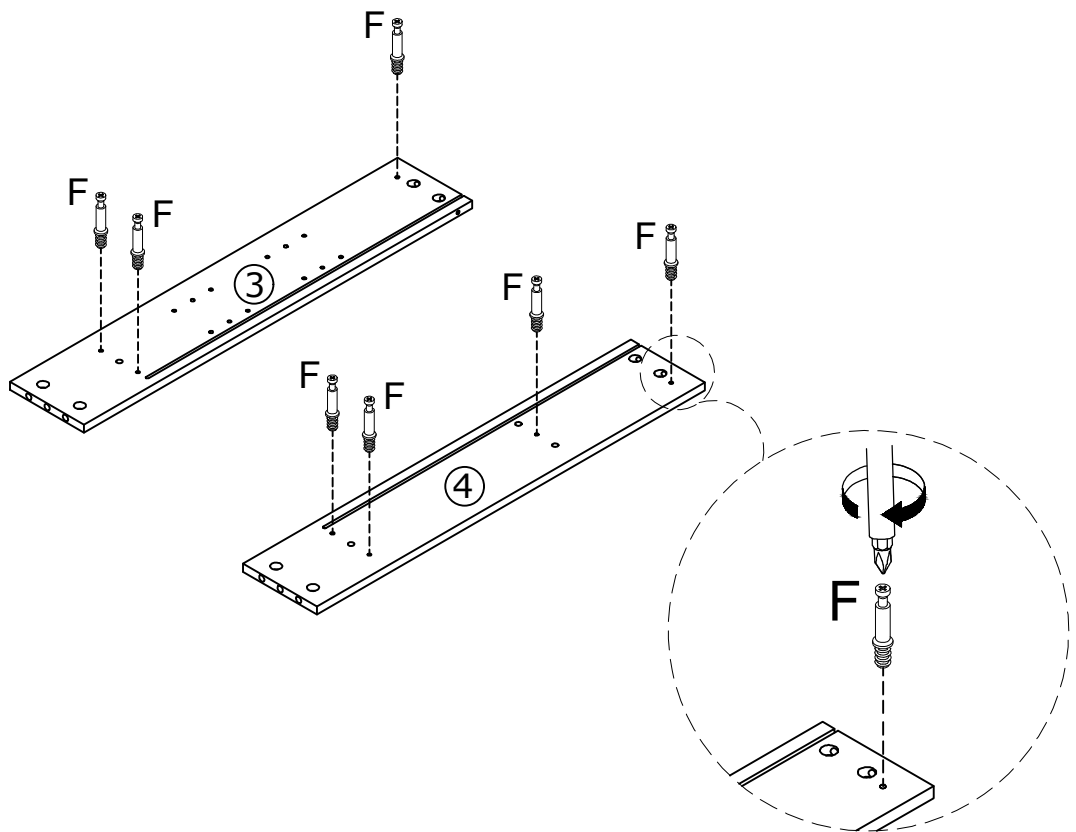
F 
Ø6×35mm x7



26

G 
Ø15×10mm x3

R 
Ø6×30mm x1

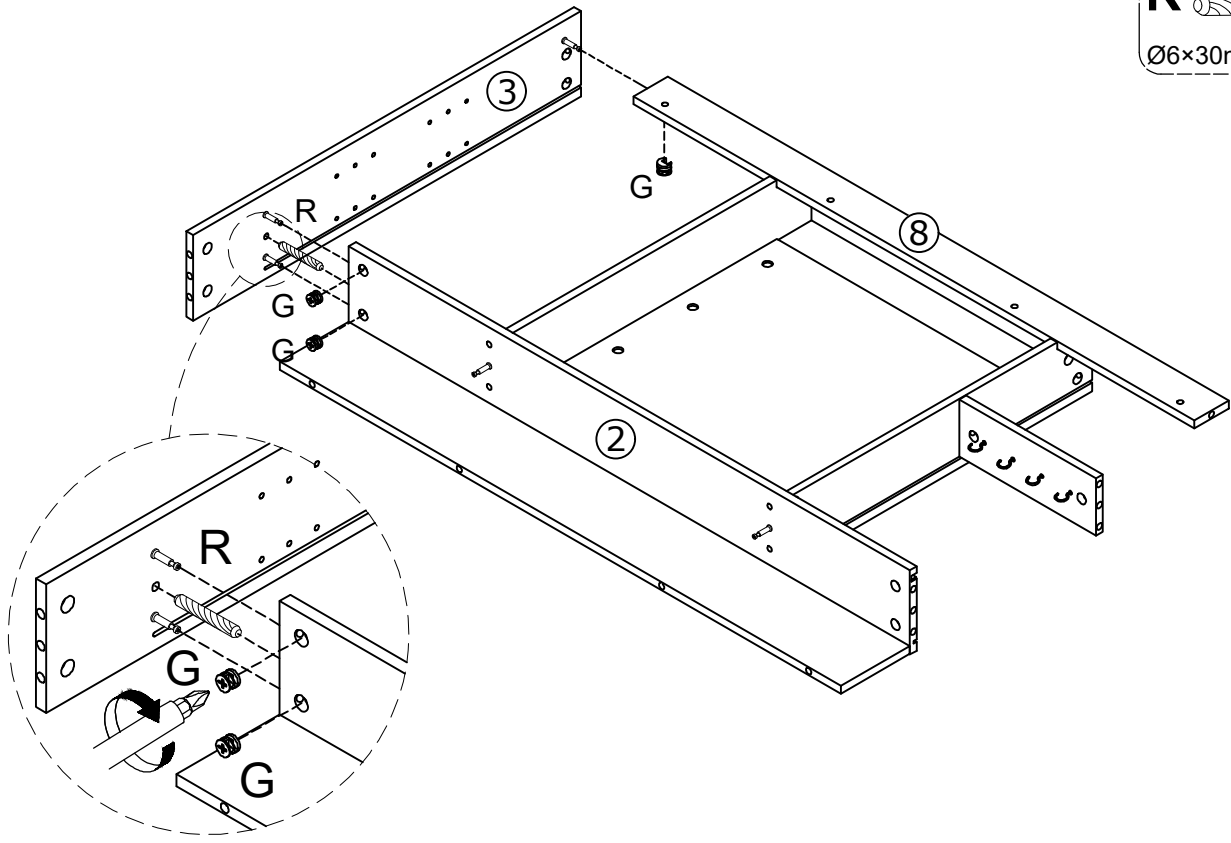

27

G 
Ø15×10mm x4

R 
Ø6×30mm x3

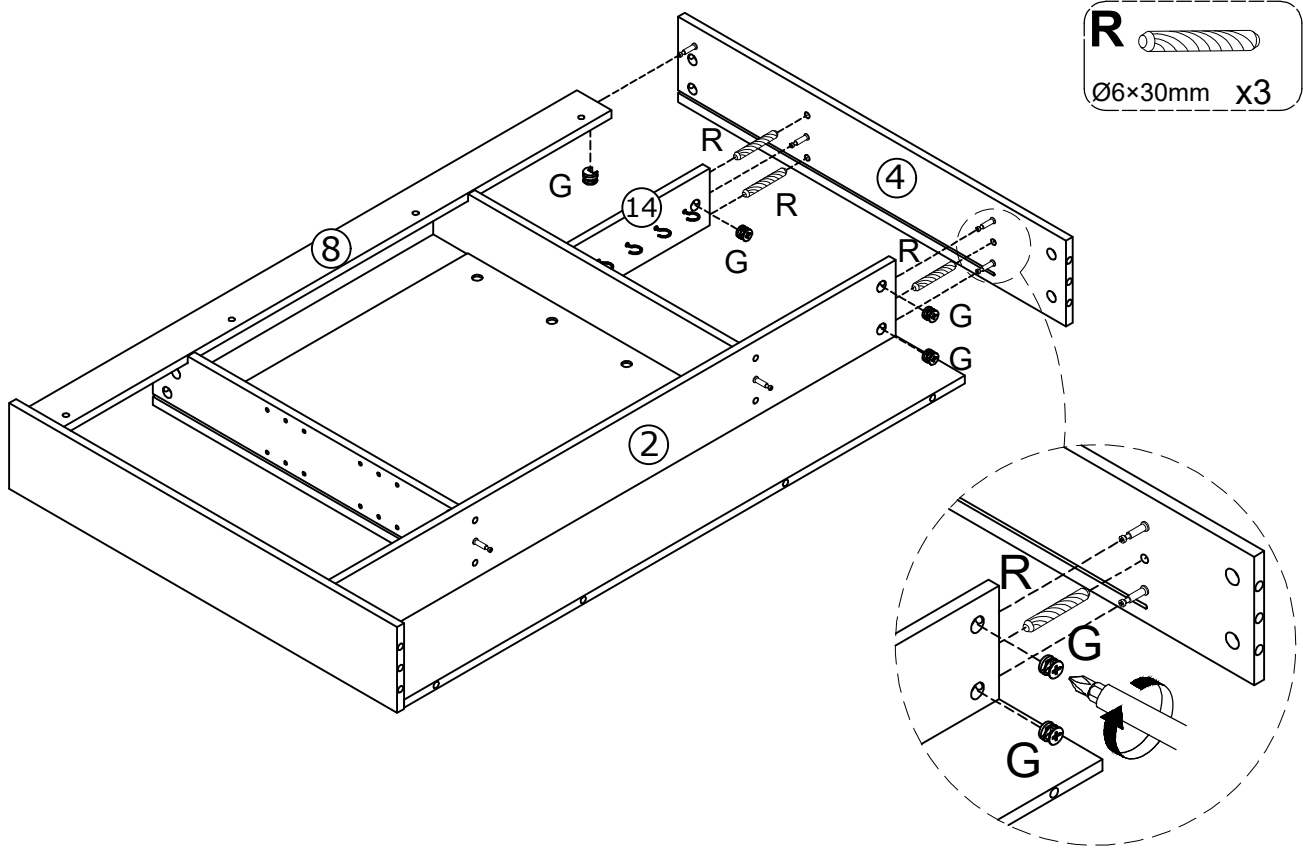

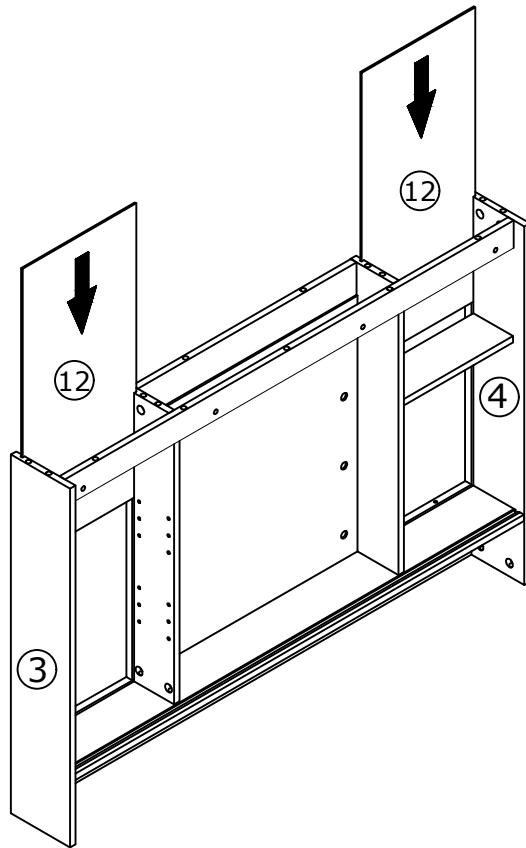

28



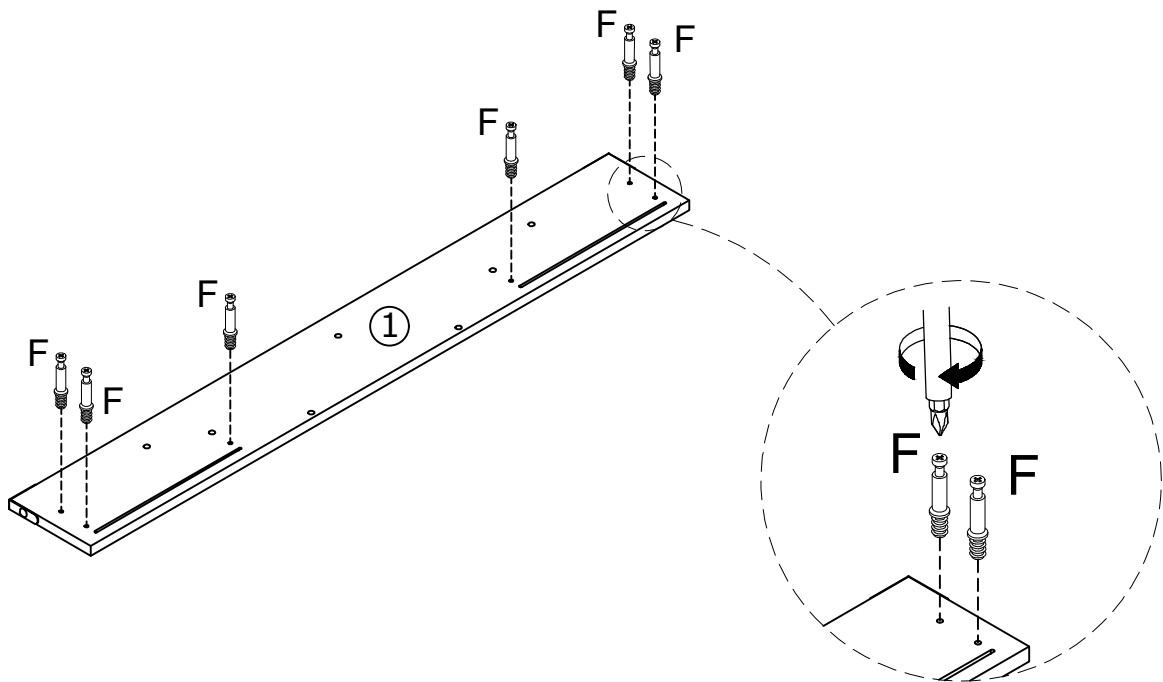
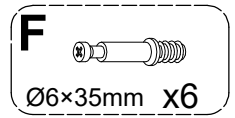

29

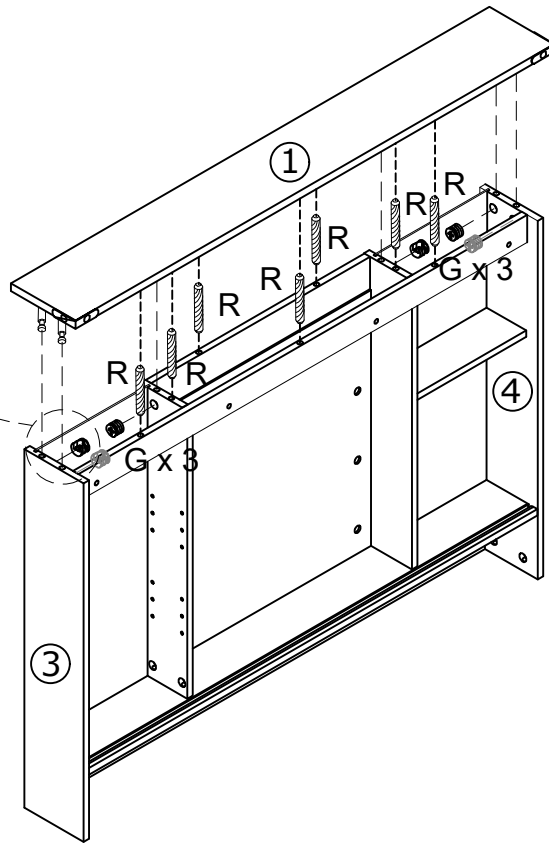
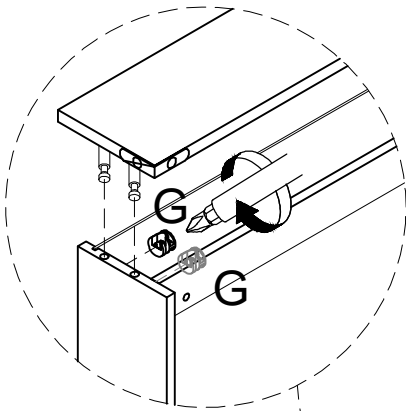

G 
Ø15×10mm x6

R 
Ø6×30mm x7



G 
Ø15×10mm x6

R 
Ø6×30mm x6

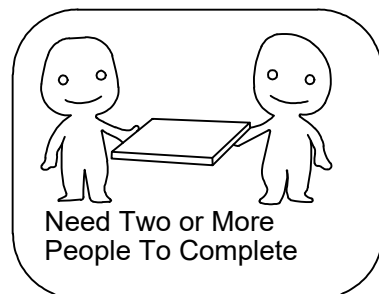
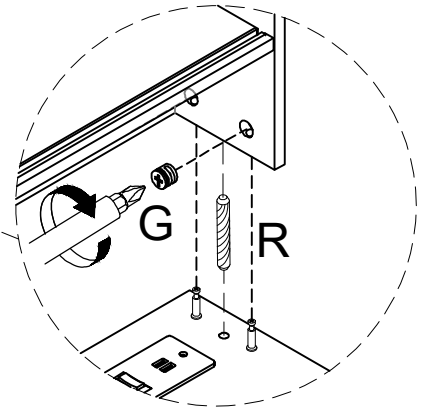
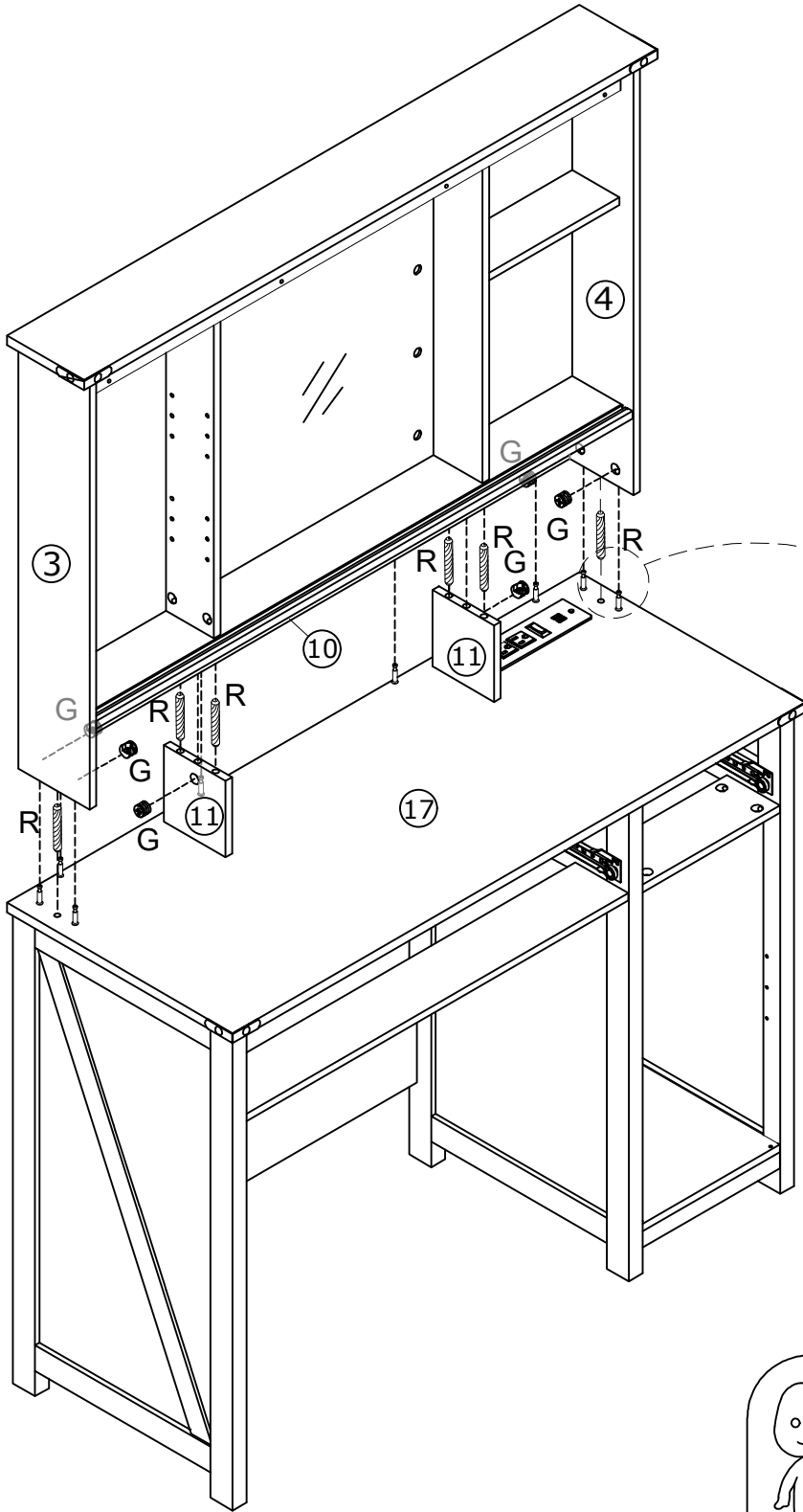

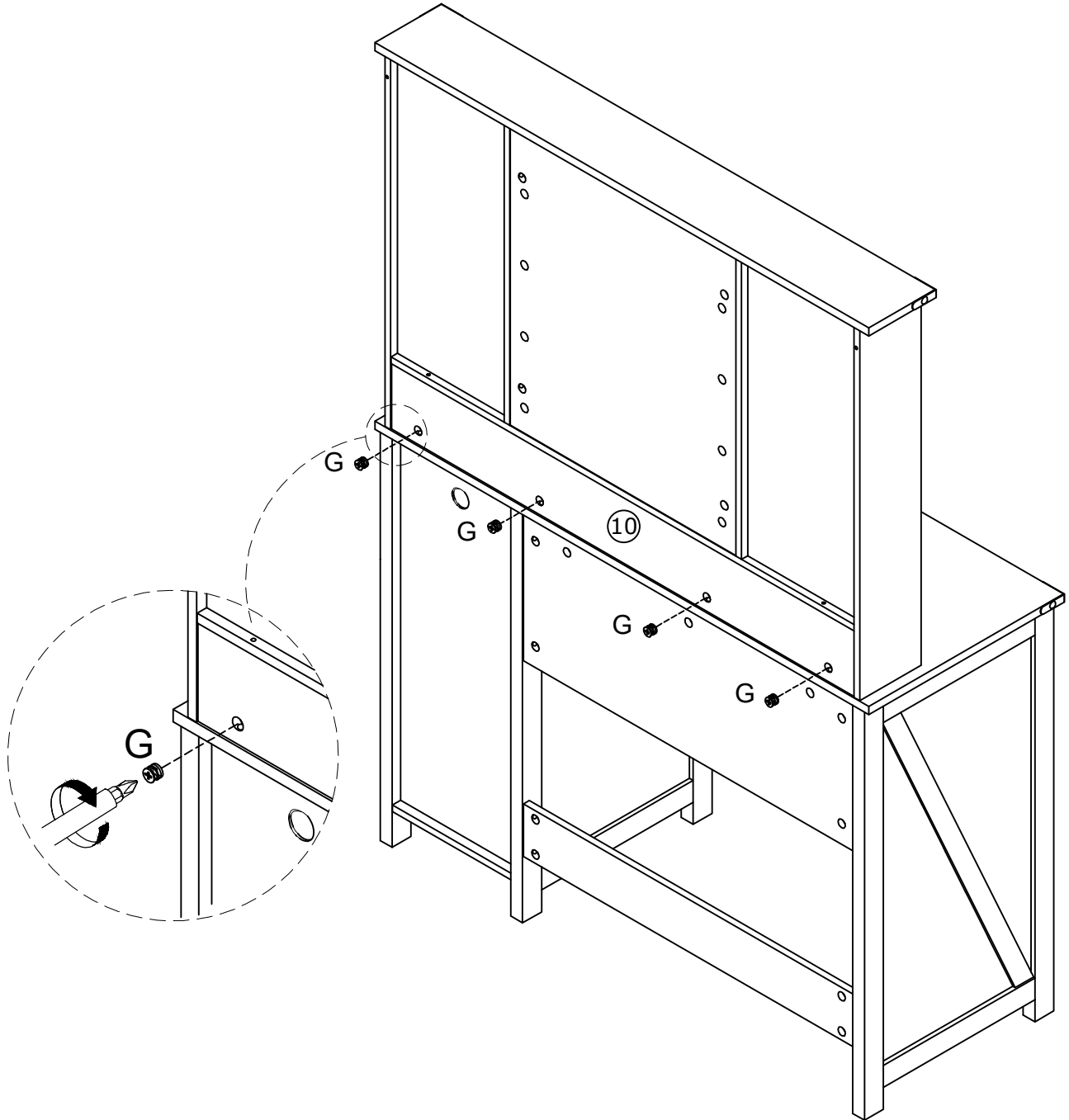

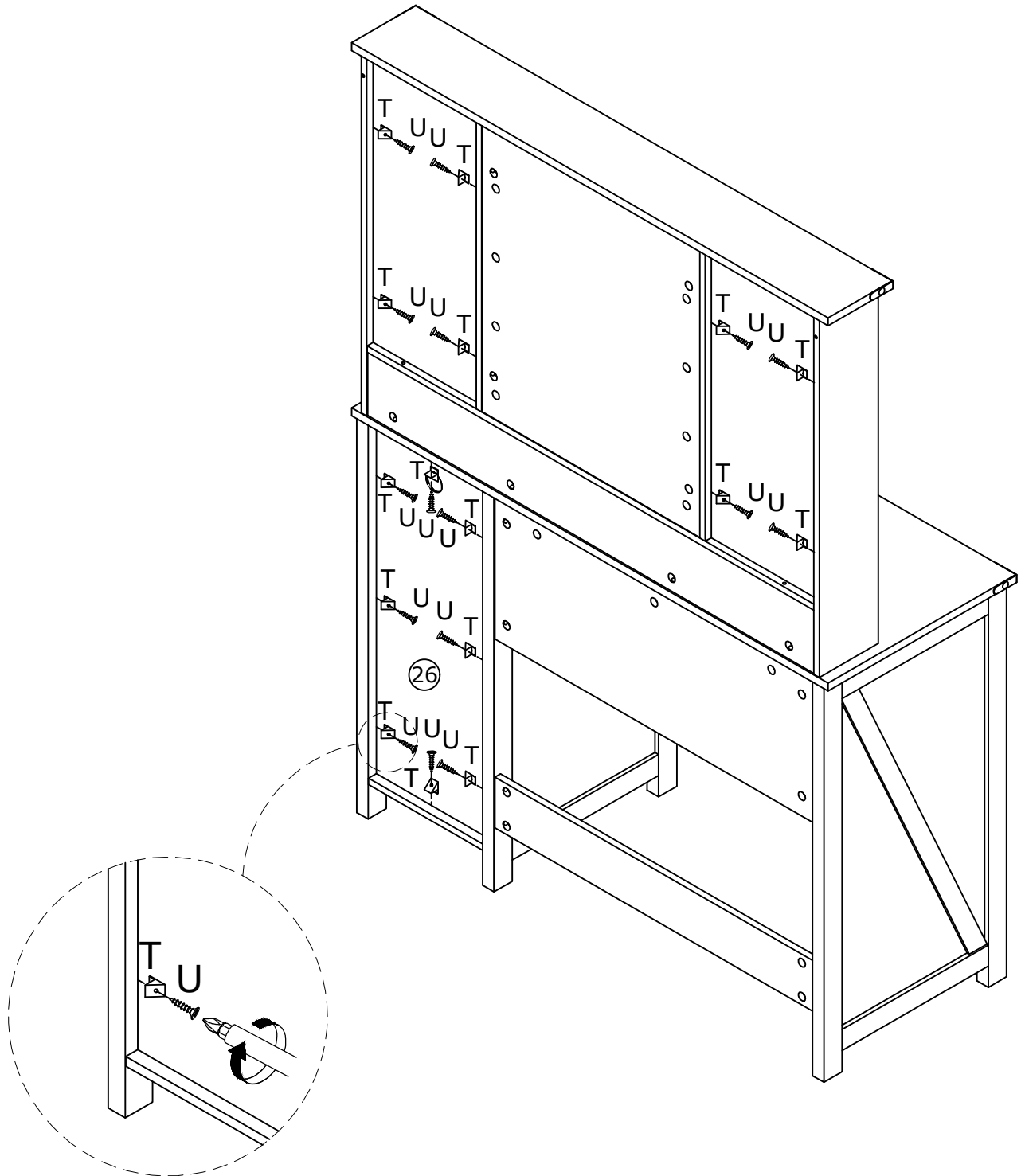
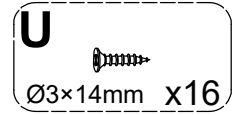
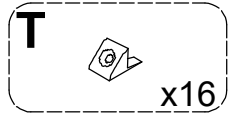

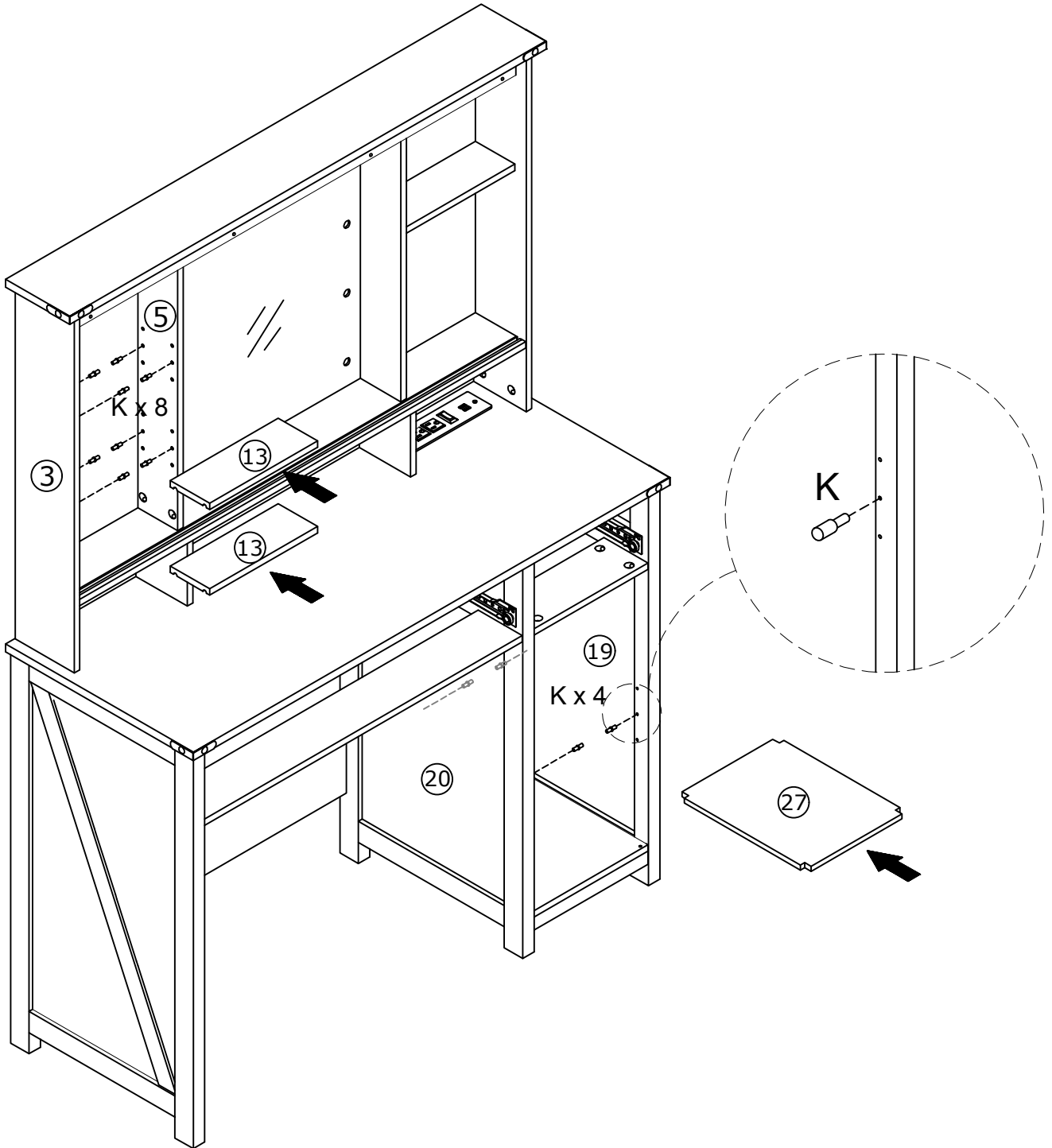



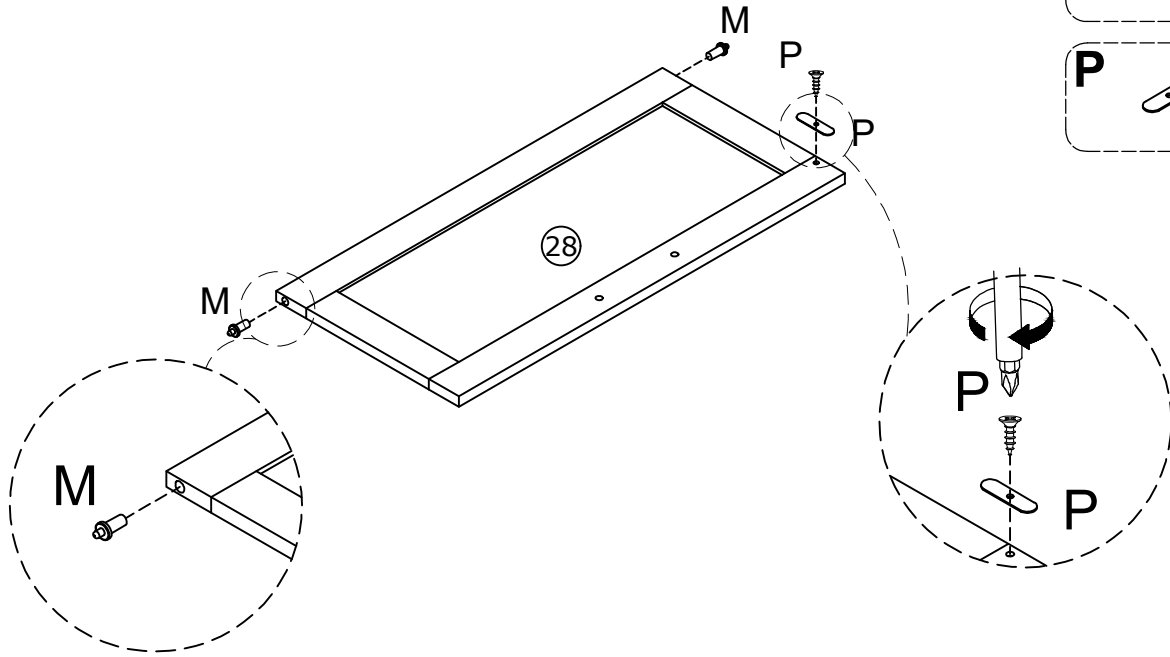

35

- P**  Ø3×12mm x1
- M**  x2
- P**  x1

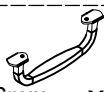

36

- V**  Ø4×16mm x2
- W**  L=96mm x1

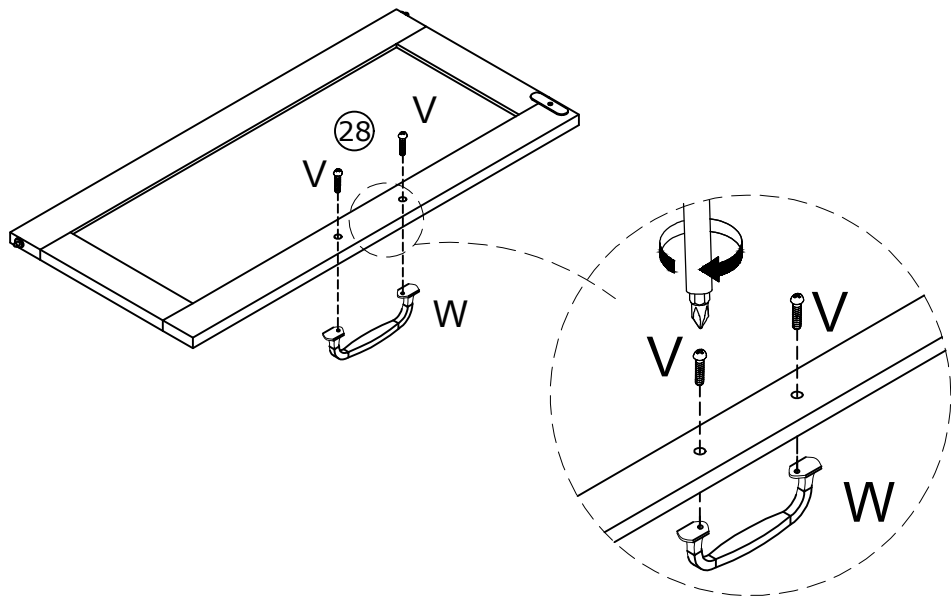

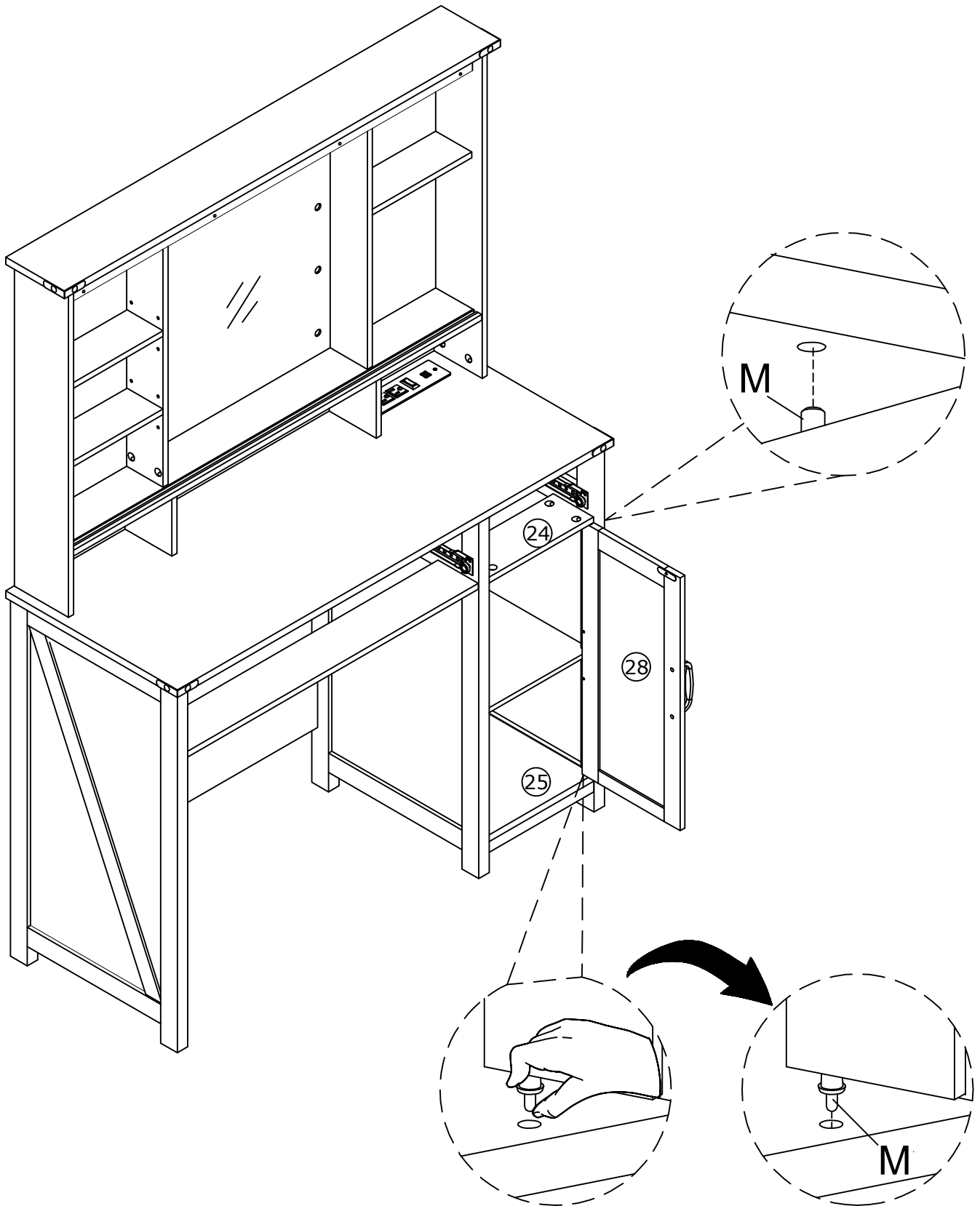

38

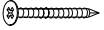
H 
Ø4×30mm x4

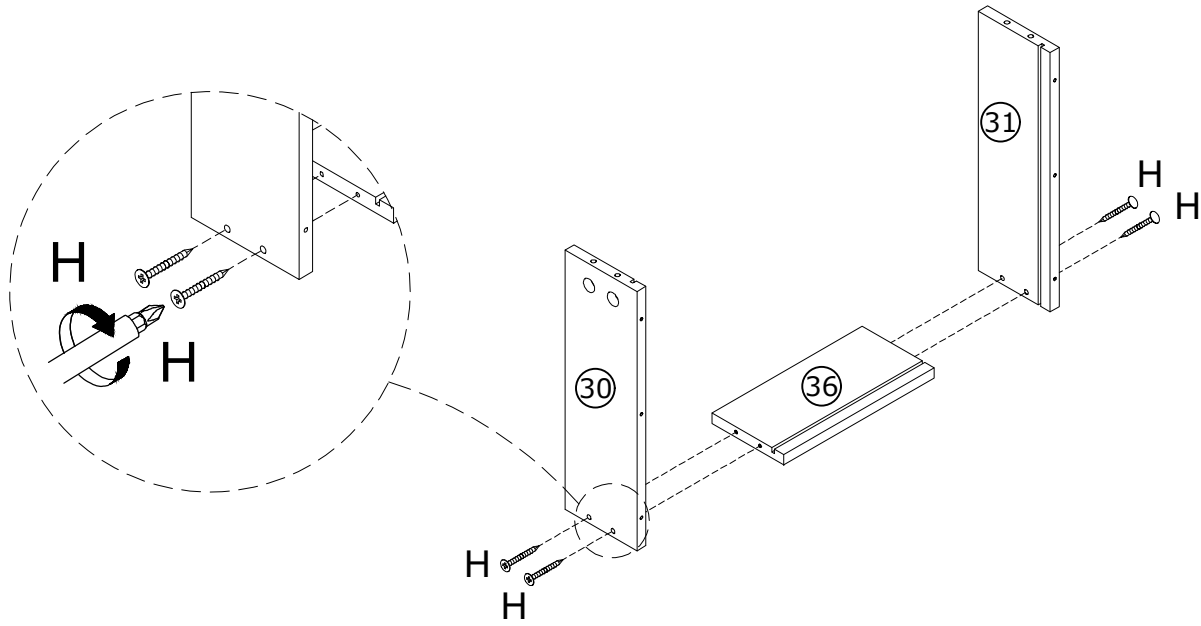

39

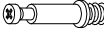
F 
Ø6×35mm x4

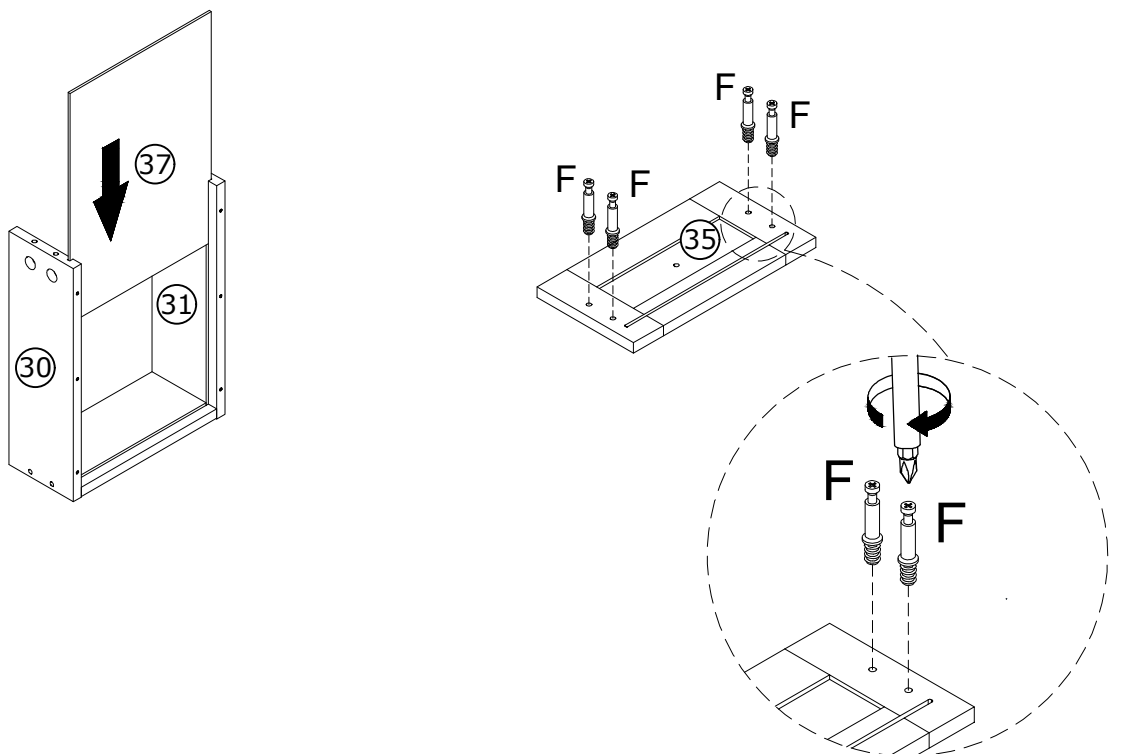

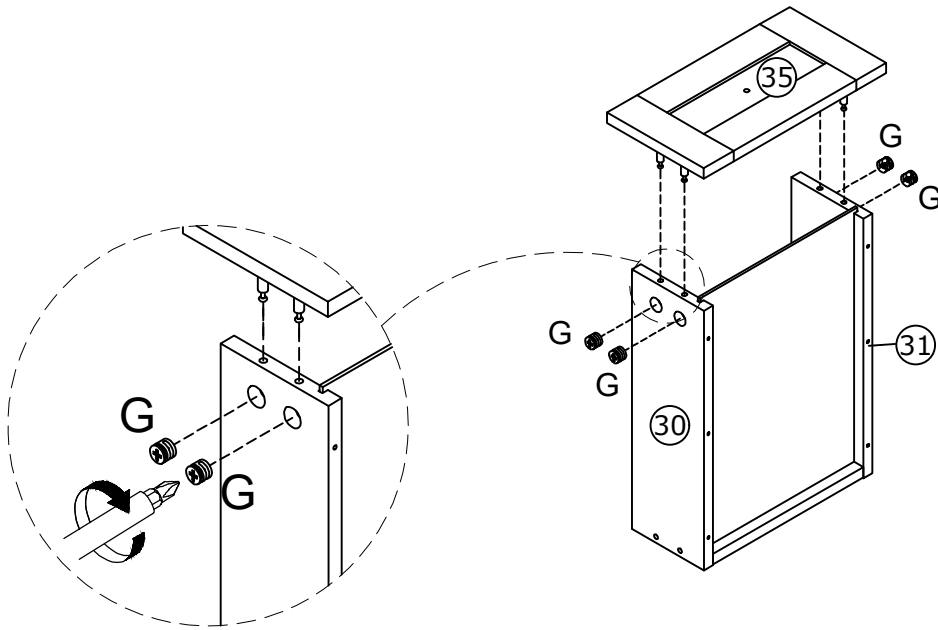

40

G 
Ø15×10mm x4



41

Q 
Ø4×8mm x1

X 
x1

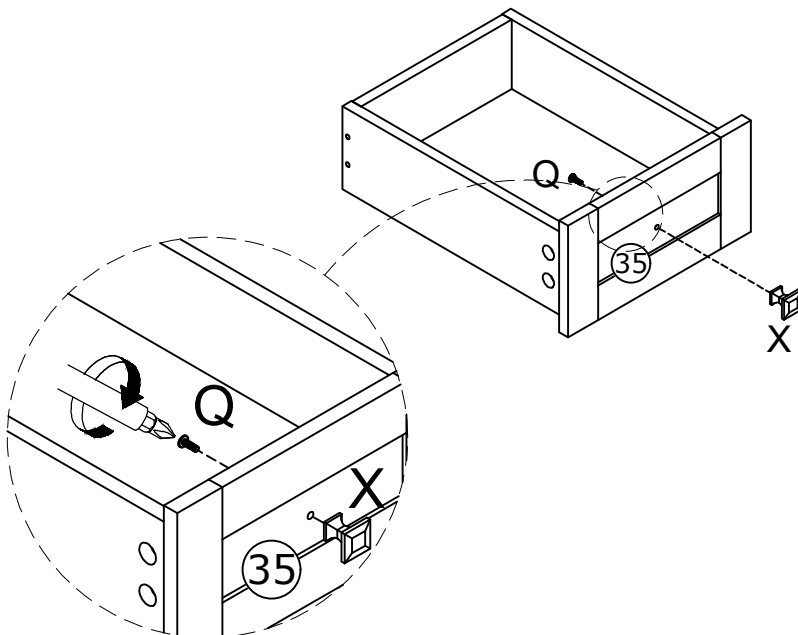

42

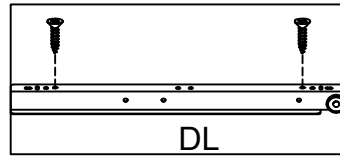
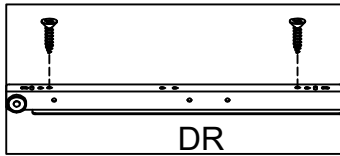

DR
L300mm(R) X1

DL
L300mm(L) X1

E
Ø3.5x12mmX4

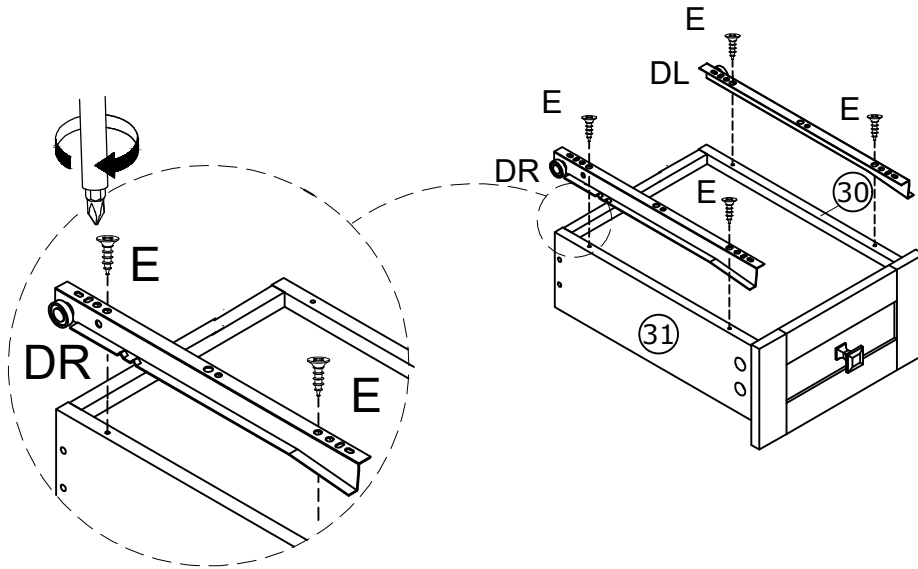

43

H
Ø4x30mm x5

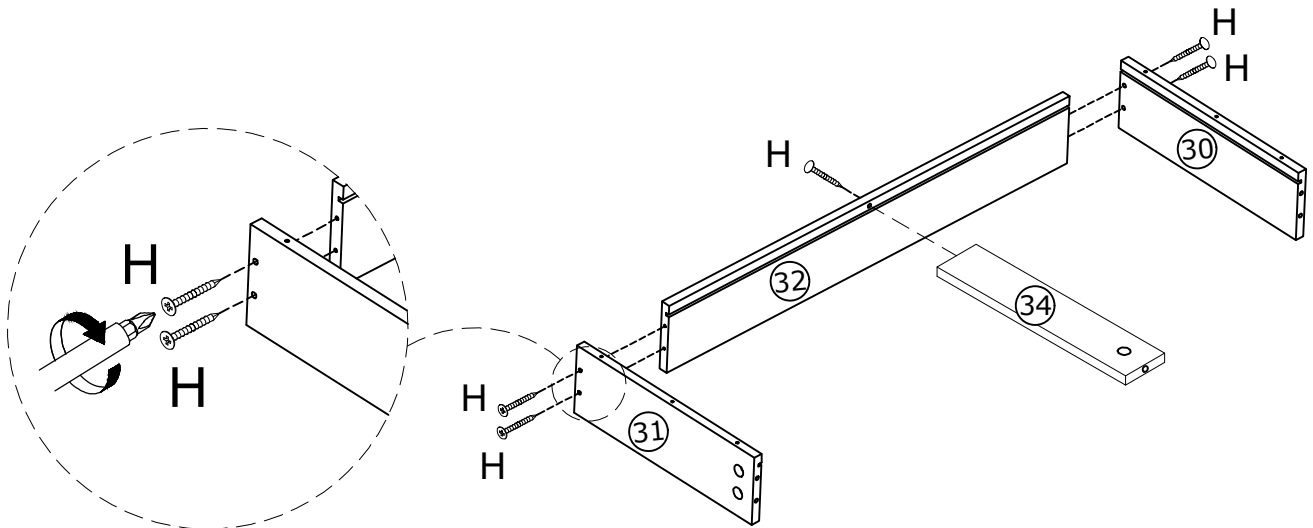

44

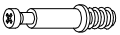
F 
Ø6×35mm x5

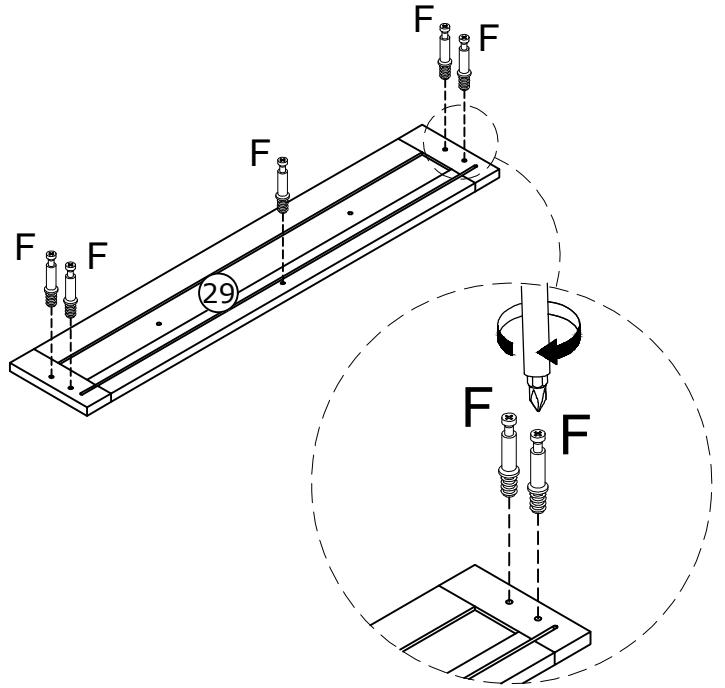
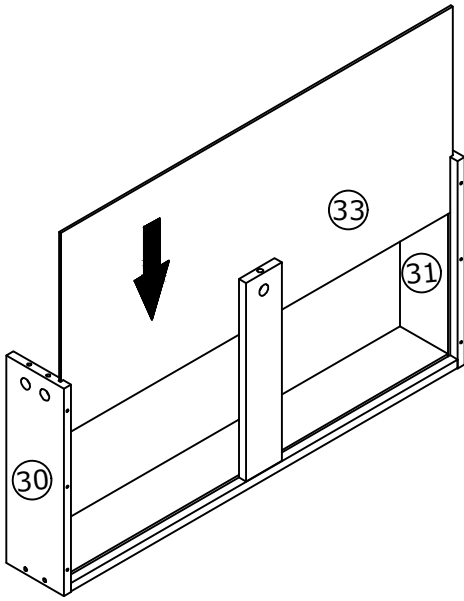

45

G 
Ø15×10mm x5

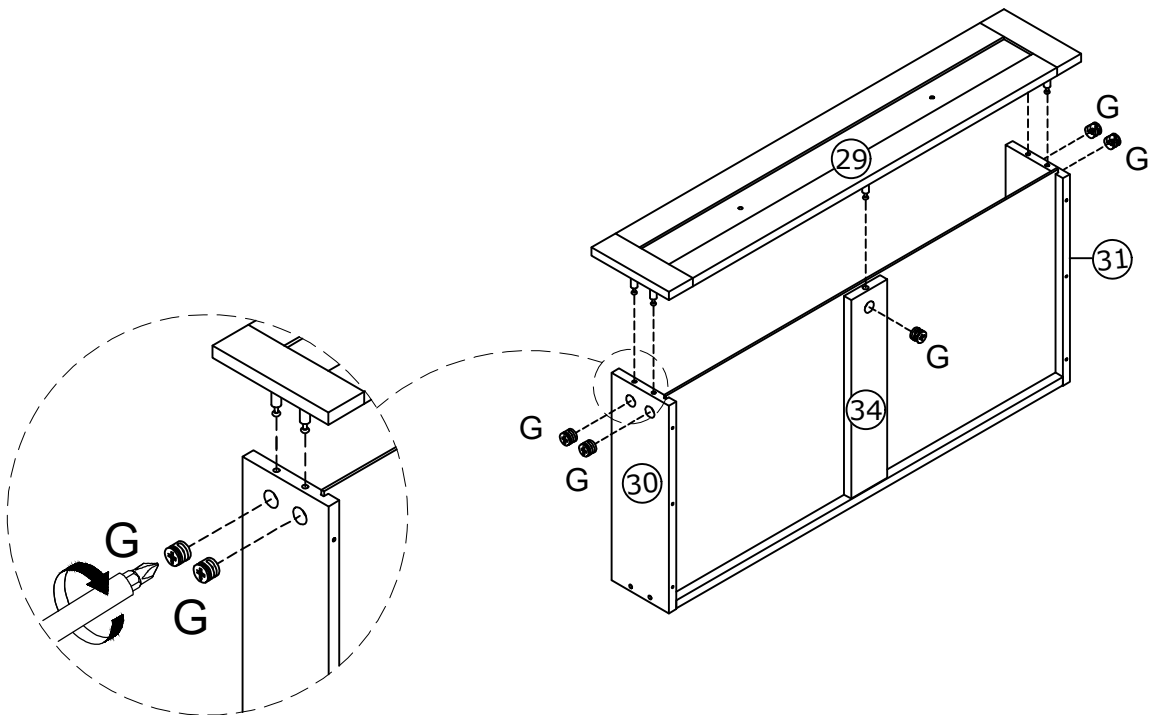



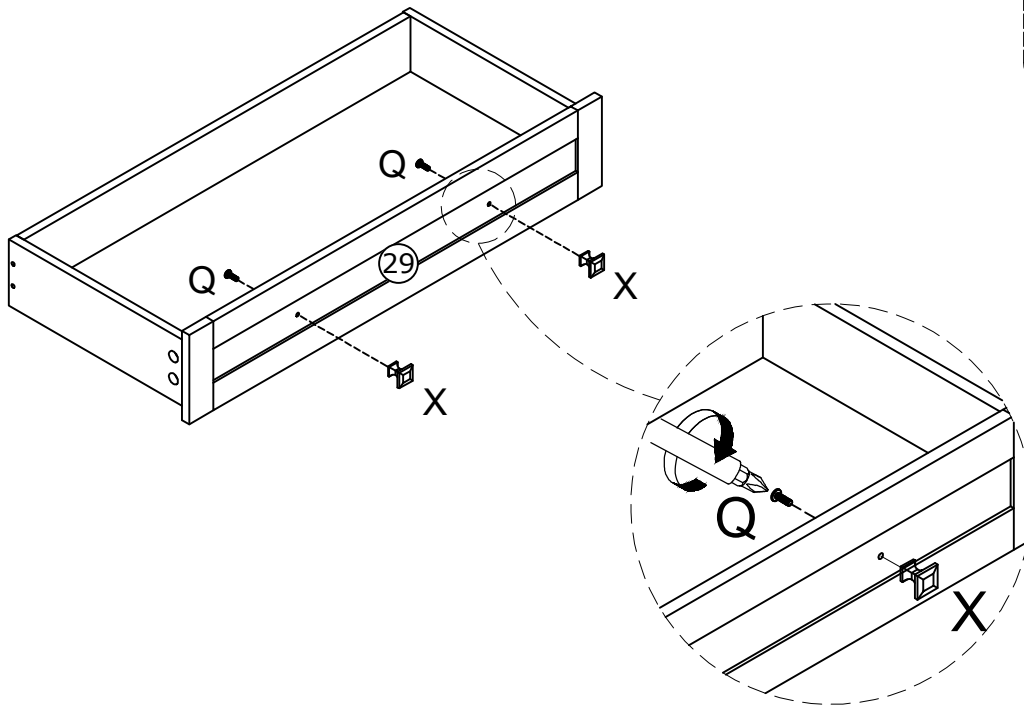
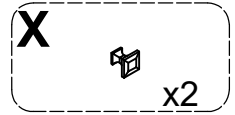
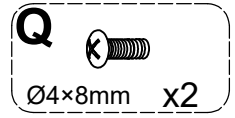

46

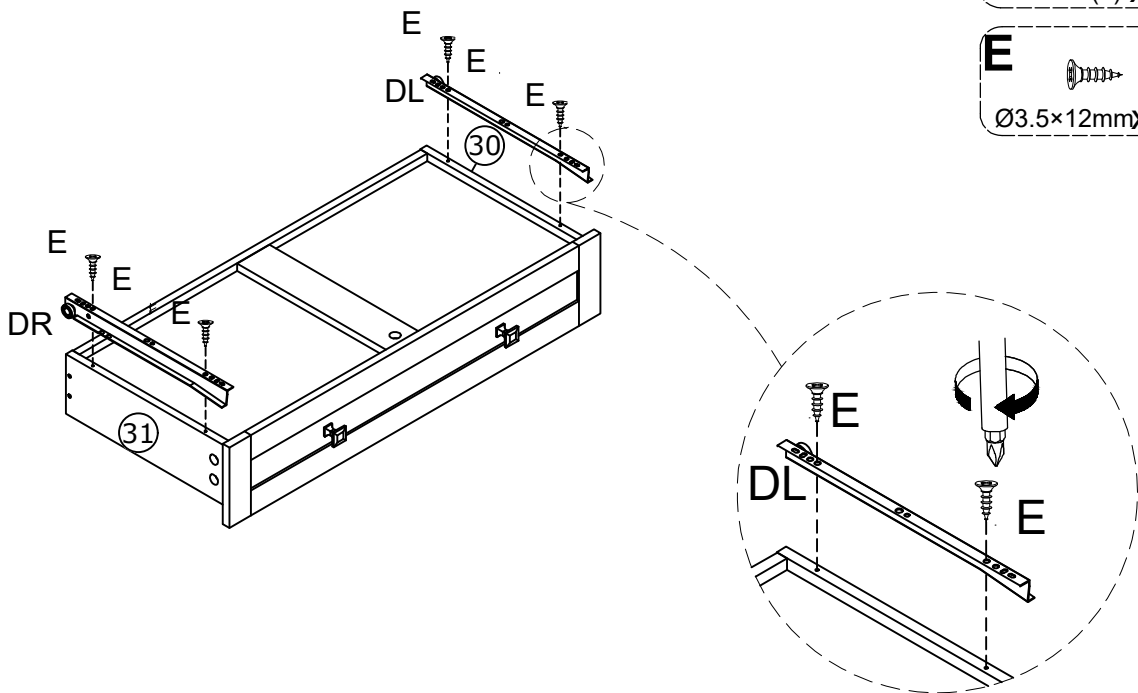
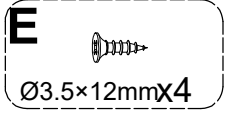
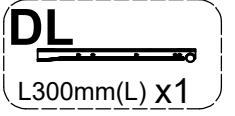
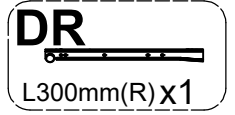
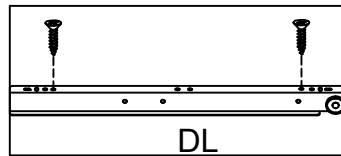
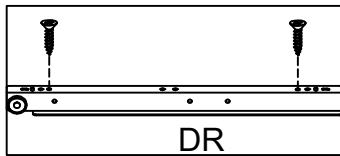

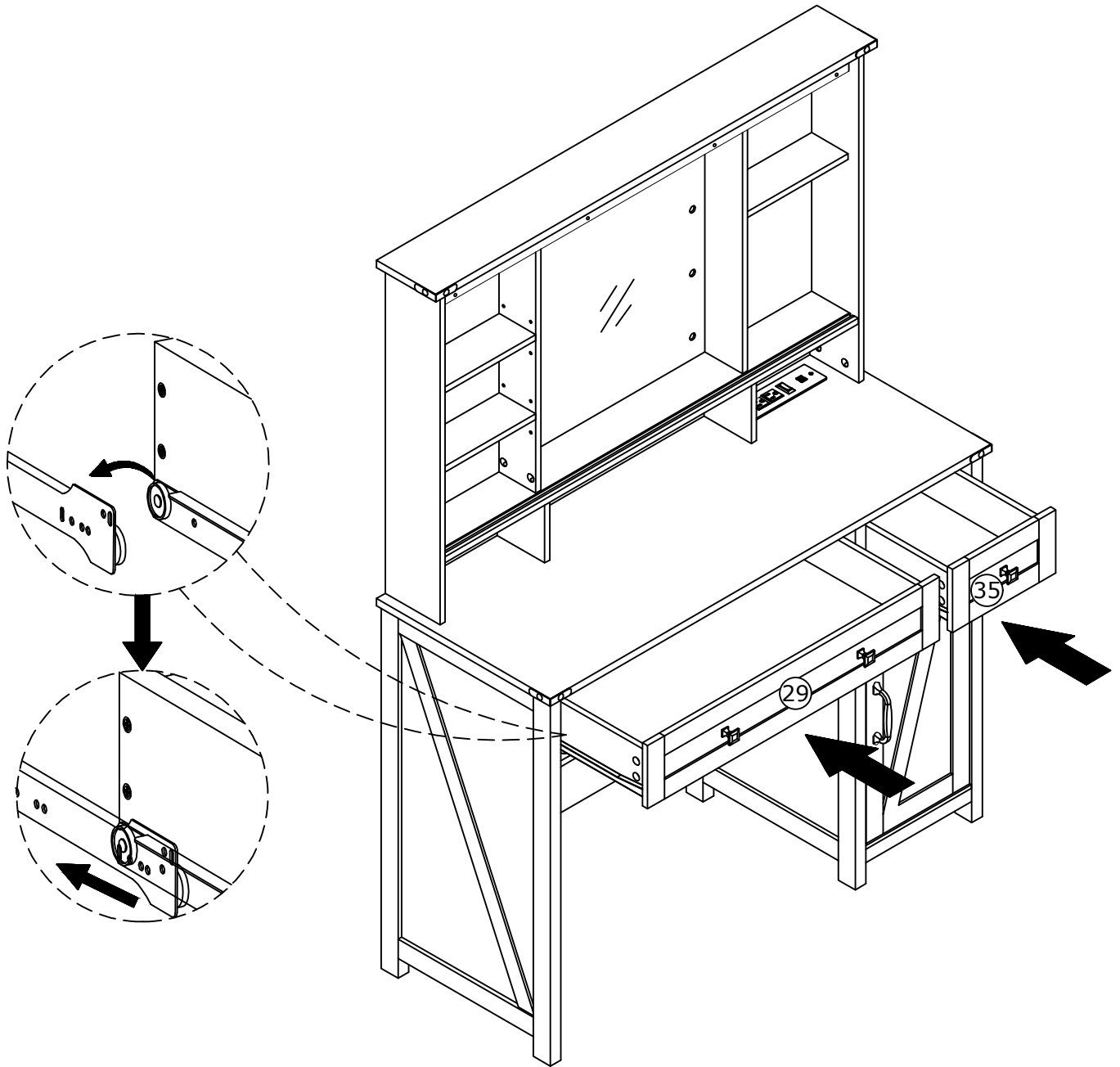

47



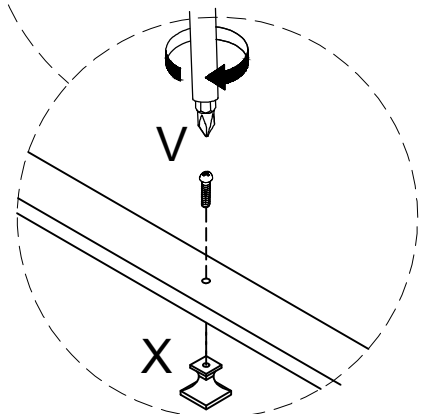
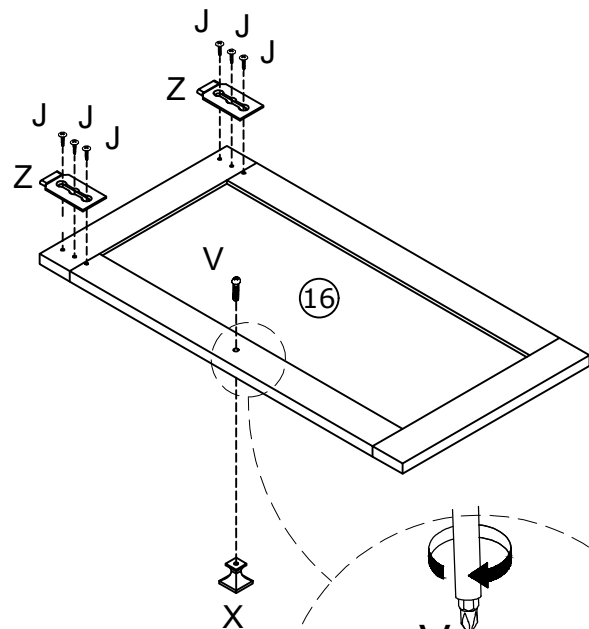
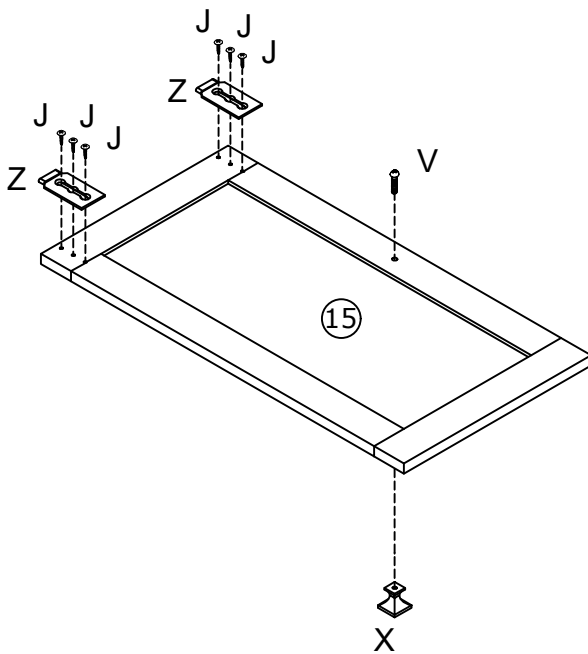
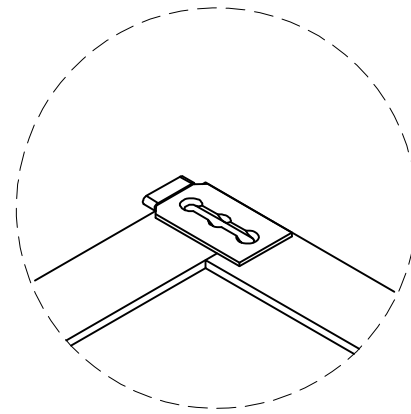
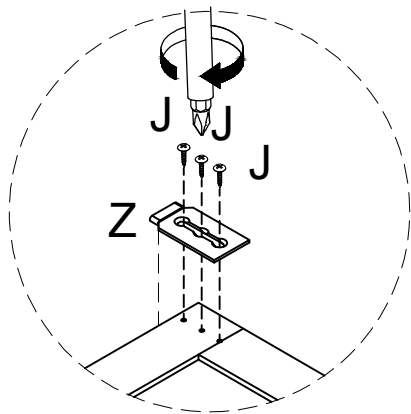

- J**  Ø4×12mm x12
- V**  Ø4×16mm x2
- X**  x2
- Z**  x4



- a**  x4
- b**  Ø6×25mm x4

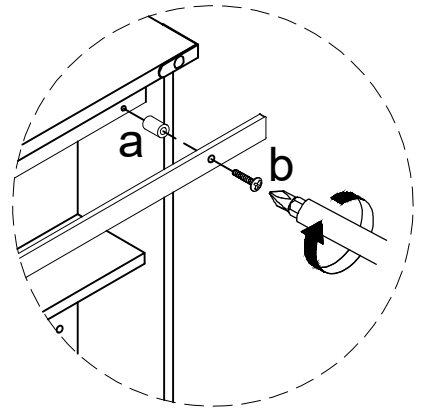
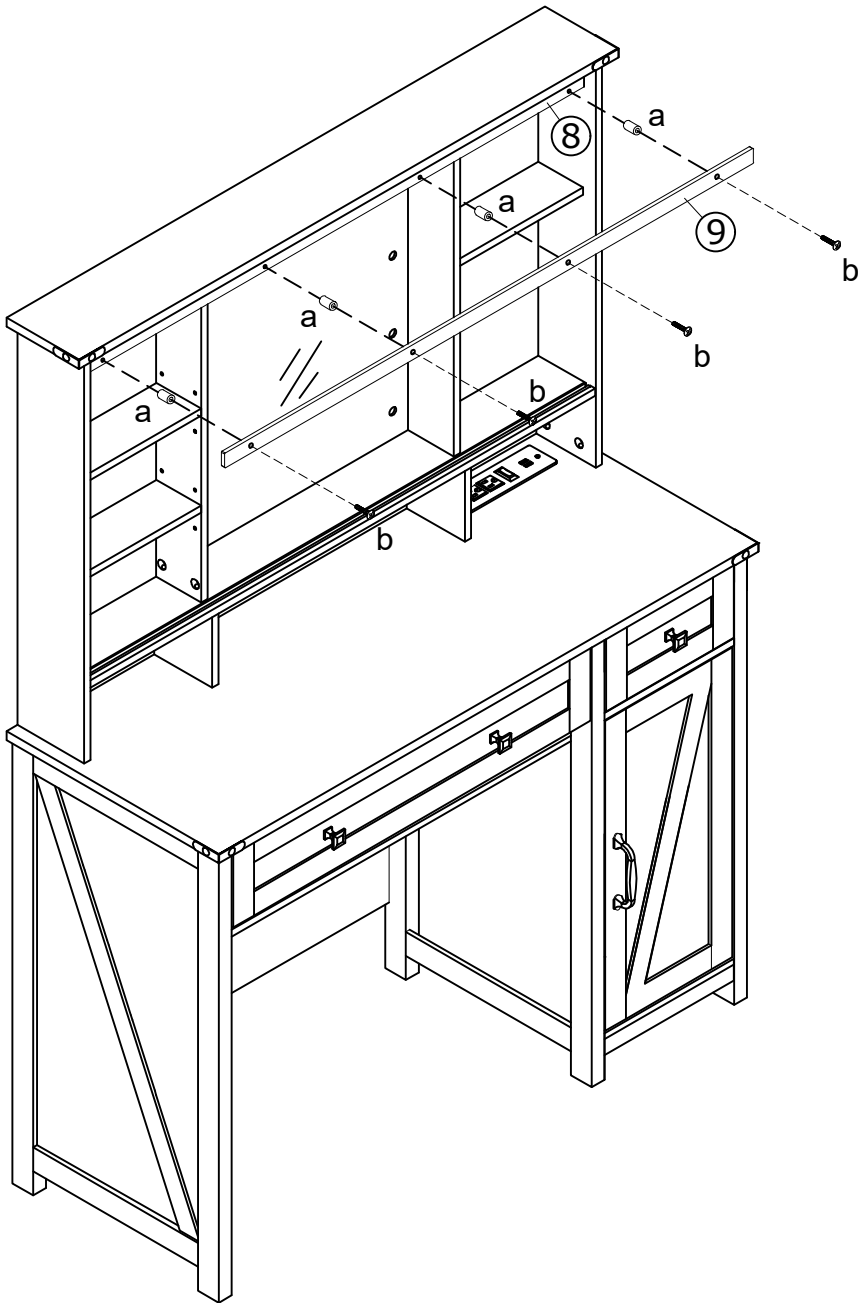

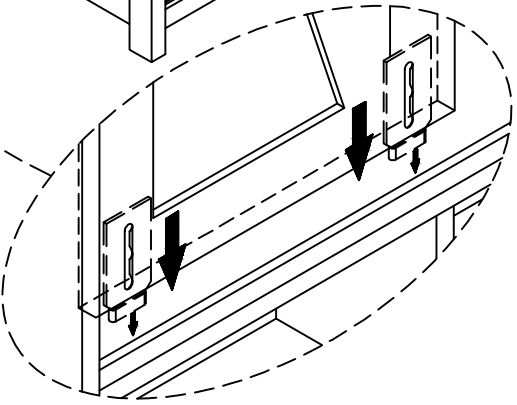
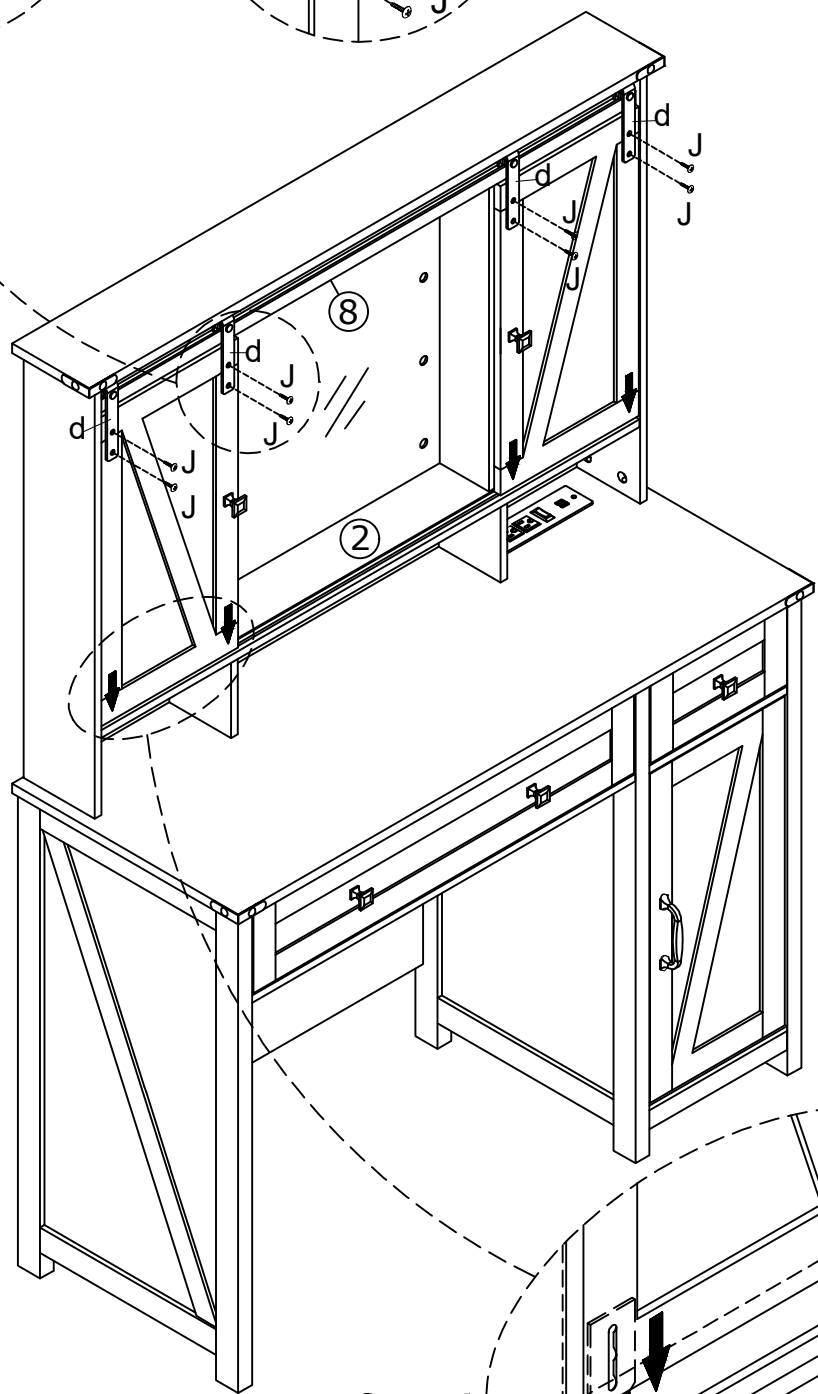
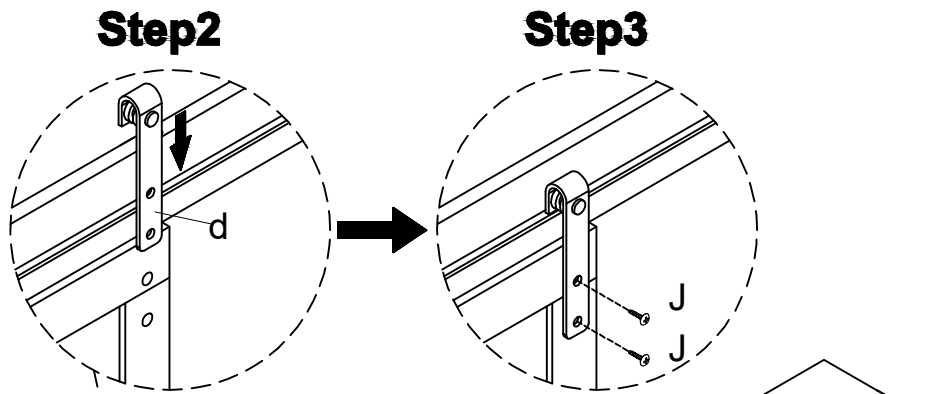
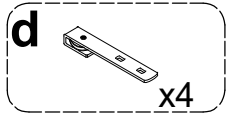
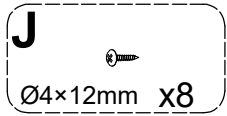

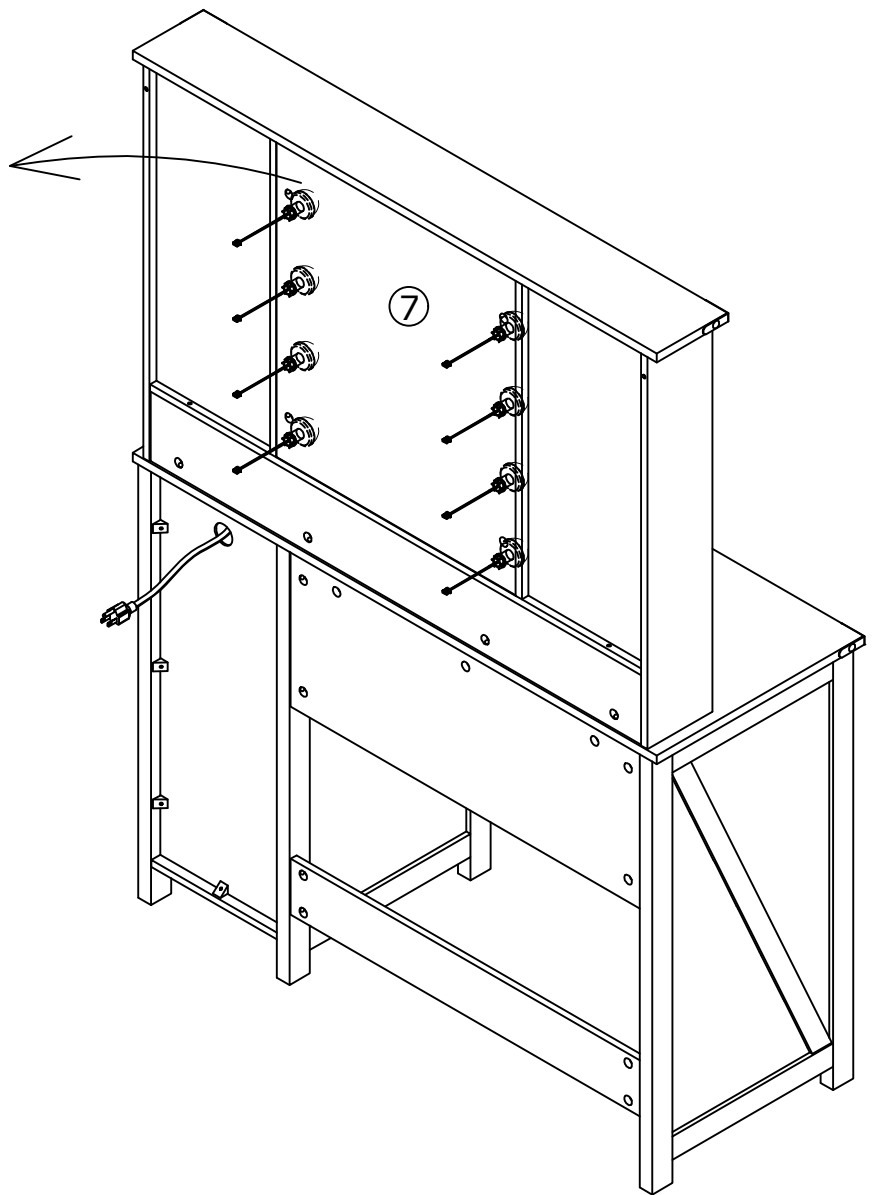
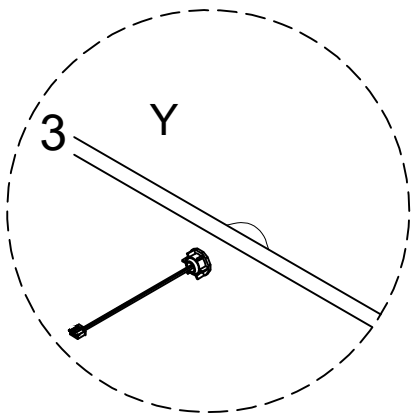
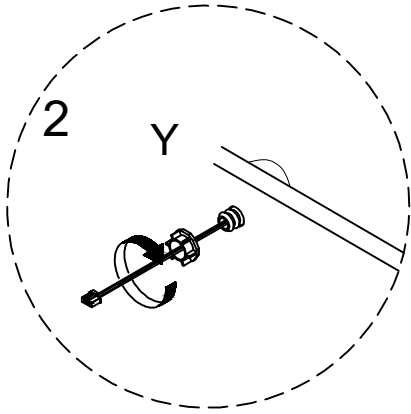
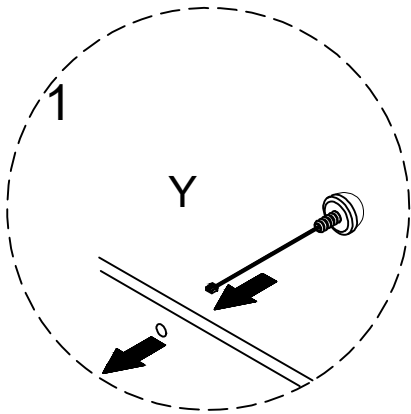
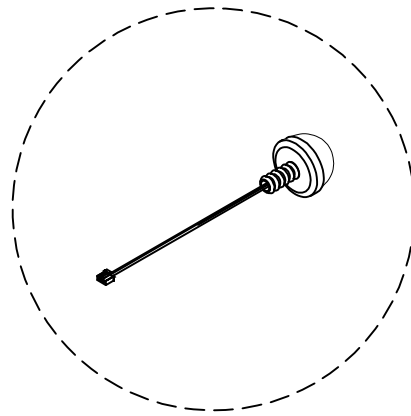
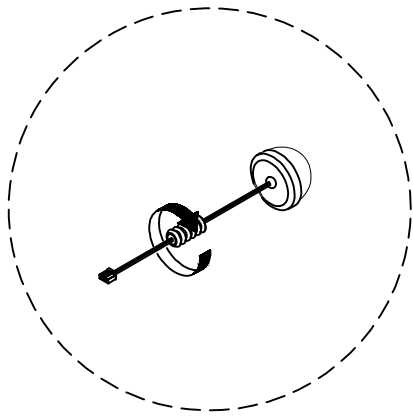
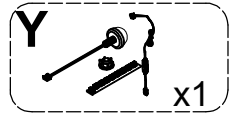

Please note that each terminal
of **Y** can be used

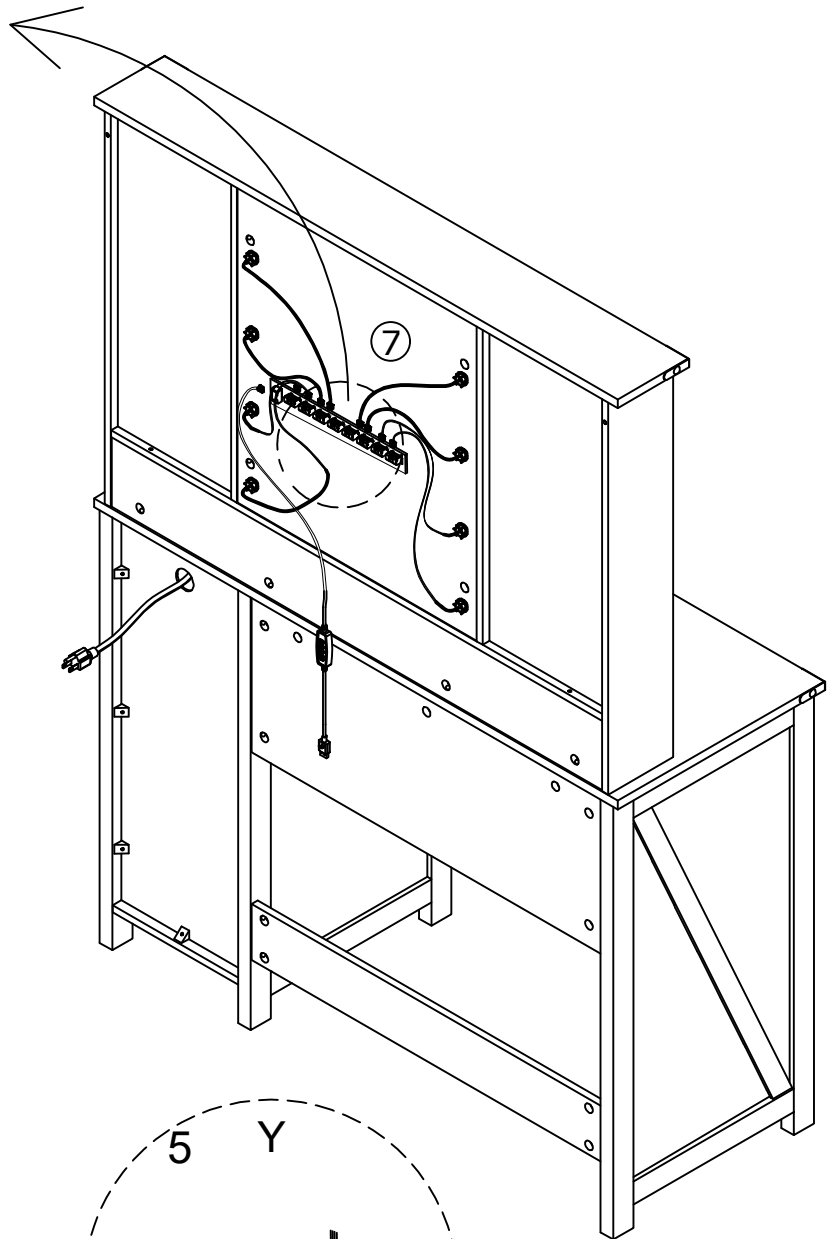
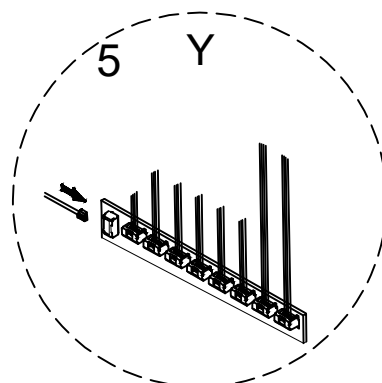
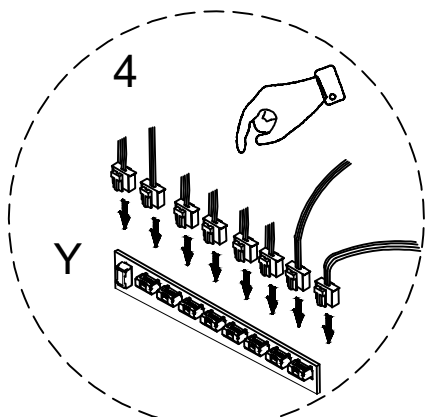
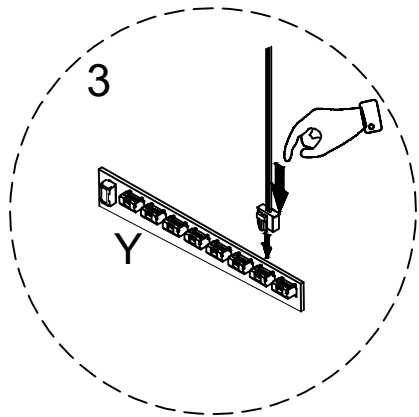
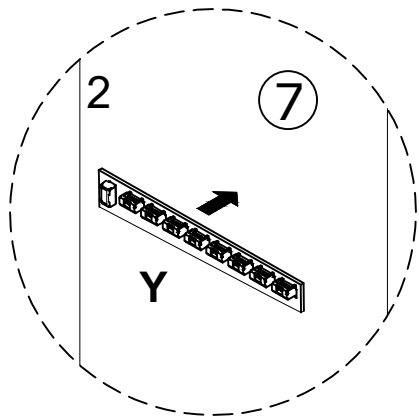
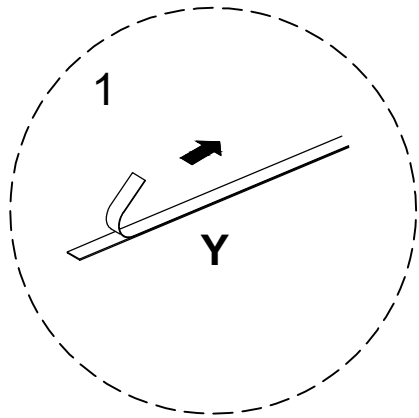

S 
Ø15mm x6

