

Pure & Easy



# **ASSEMBLY INSTRUCTIONS**

# NOTICE

IMPORTANT, RETAIN FOR FUTURE REFERENCE: READ CAREFULLY  
WICHTIG, FÜR SPÄTERE NACHSCHLAGE AUFBEWAHREN: SORGFÄLTIG LESEN  
IMPORTANTE, GUARDAR PARA REFERENCIA POSTERIOR: LEER ATENTAMENTE  
IMPORTANTE, CONSERVARE PER RIFERIMENTI FUTURI: LEGGERE ATTENTAMENTE  
IMPORTANT, À CONSERVER POUR RÉFÉRENCE FUTURE : LIRE ATTENTIVEMENT

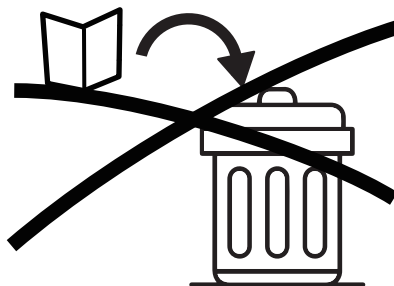
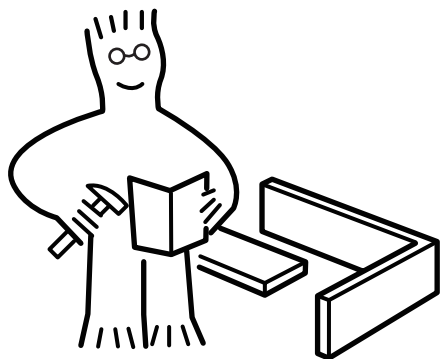

Assemble on a flat, clean and soft surface.

Auf einer flachen, sauberen und weichen Oberfläche zusammenbauen.

Assembler sur une surface plate, propre et douce.

Assemblare su una superficie piatta, pulita e morbida.

Ensamblar sobre una superficie plana, limpia y suave.

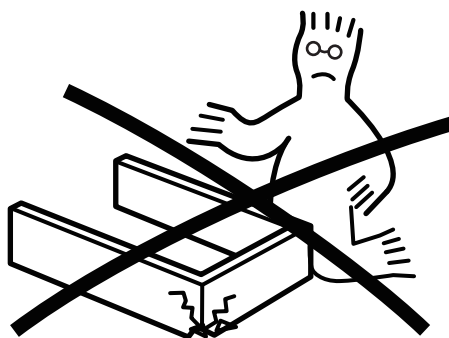
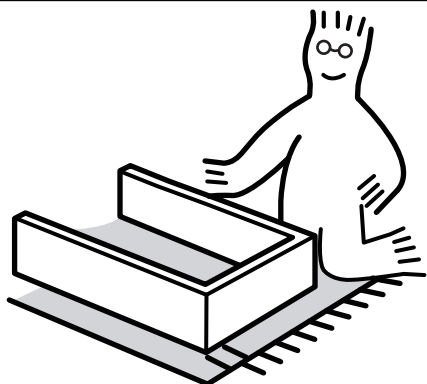

Professional installation is highly recommended.

Eine professionelle Installation wird dringend empfohlen.

Une installation professionnelle est fortement recommandée.

Si raccomanda vivamente l'installazione professionale.

Se recomienda altamente la instalación profesional.



Periodically check that all components are tightly secured.

Überprüfen Sie Regelmäßig, Dass Alle Komponenten Fest Gesichert Sind.

Vérifiez Périodiquement Que Tous Les Composants Sont Bien Fixés.

Controllare Periodicamente Che Tutti I Componenti Siano Ben Fissati.



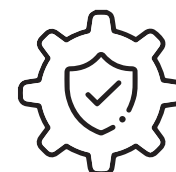

Verifique Periódicamente Que Todos Los Componentes Estén Bien Asegurados.

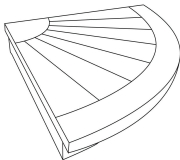
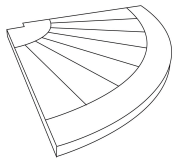

- Do not fully tighten all bolts until all components are in place. Failure to follow these instructions may cause the bolts to misalign during assembly.
  - Keep away from high - temperatures and strong oxidants.
  - In sunlight, there is no need to cover the table with a sealed dust - proof cover, as high temperatures can deform the material.
  - In an outdoor environment, the table does not require any protection, no painting or staining. It only needs to be cleaned with soap, water, and a soft - bristle brush or an abrasive sponge.
  - Children should not climb or jump on the table.
- 
- Vollziehen Sie alle Bolzen nicht vollständig, bevor alle Komponenten in Position sind. Die Nichtbeachtung dieser Anweisungen kann dazu führen, dass sich die Bolzen während des Montierens versetzen .
  - Halten Sie sich von hohen Temperaturen und starken Oxidationsmitteln fern .
  - In Sonnenschein ist es nicht erforderlich, den Tisch mit einer versiegelten Staubschutzabdeckung zu bedecken, da hohe Temperaturen das Material verformen können .
  - In outdoor-Umgebungen bedarf der Tisch keiner Schutzmaßnahmen – keine Bemalung oder Färbung. Reinigen Sie ihn einfach mit Seife, Wasser und einer weichen Bürste oder einem abrasiven Schwamm .
  - Kinder sollten nicht auf dem Tisch klettern oder springen.
- 
- Ne serrez pas complètement tous les boulons avant que tous les composants ne soient en place. Le non-respect de ces instructions peut entraîner un désalignement des boulons lors de l'assemblage.
  - Éloignez-vous des hautes températures et des forts oxydants.
  - En présence de soleil, il n'est pas nécessaire de couvrir la table d'un couvercle hermétique anti-poussière, car les températures élevées peuvent déformer le matériau.
  - En environnement extérieur, la table n'a pas besoin de protection—aucune peinture ou teinture. Nettoyez-la simplement avec du savon, de l'eau et une brosse douce ou un éponge abrasif.
  - Les enfants ne devraient pas grimper ou sauter sur la table.

- Non serrare completamente tutti i bulloni prima che tutti i componenti siano in posizione. Il non rispetto di queste istruzioni può causare un allineamento errato dei bulloni durante l'assemblaggio.
  - Mantenere lontano da alte temperature e forti ossidanti.
  - Alla luce del sole, non è necessario coprire il tavolo con un coperchio ermetico ant polvere, poiché le alte temperature possono deformare il materiale.
  - In ambiente esterno, il tavolo non richiede protezione—nessuna vernice o tintura. Puliscilo semplicemente con sapone, acqua e una spazzola morbida o una spugna abrasiva.
  - I bambini non dovrebbero arrampicarsi o saltare sul tavolo.
- No afloje completamente todos los tornillos hasta que todos los componentes estén en su lugar. No seguir estas instrucciones puede causar que los tornillos se desalicen durante el ensamblaje.
  - Manténgase alejado de altas temperaturas y oxidantes fuertes.
  - En presencia de sol, no es necesario cubrir la mesa con una cubierta sellada para protegerla del polvo, ya que las altas temperaturas pueden deformar el material.
  - En un entorno al aire libre, la mesa no requiere protección alguna, ni pintura ni tinte. Sólo necesita limpiarse con jabón, agua y un cepillo blando o una esponja abrasiva.
  - Los niños no deben escalar ni saltar sobre la mesa.

## PARTS

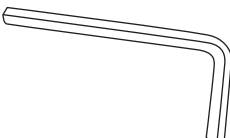
Item no. Nr. N° d'article Articolo No. Artículo No.	Reference Image Referenzbild Image de référence Immagine di riferimento Imagen de referencia	Qty. Menge Qté. Qtà Cant.	Item no. Nr. N° d'article Articolo No. Artículo No.	Reference Image Referenzbild Image de référence Immagine di riferimento Imagen de referencia	Qty. Menge Qté. Qtà Cant.
1		X1	2		X1
3		X1	A	 M6 X 35mm	X8
B		X4	C		X1

# ASSEMBLY

**1**

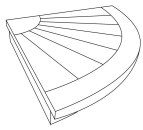

① 1pc

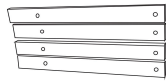

③ 1pc

M6 X 35mm



Ⓐ 4pcs

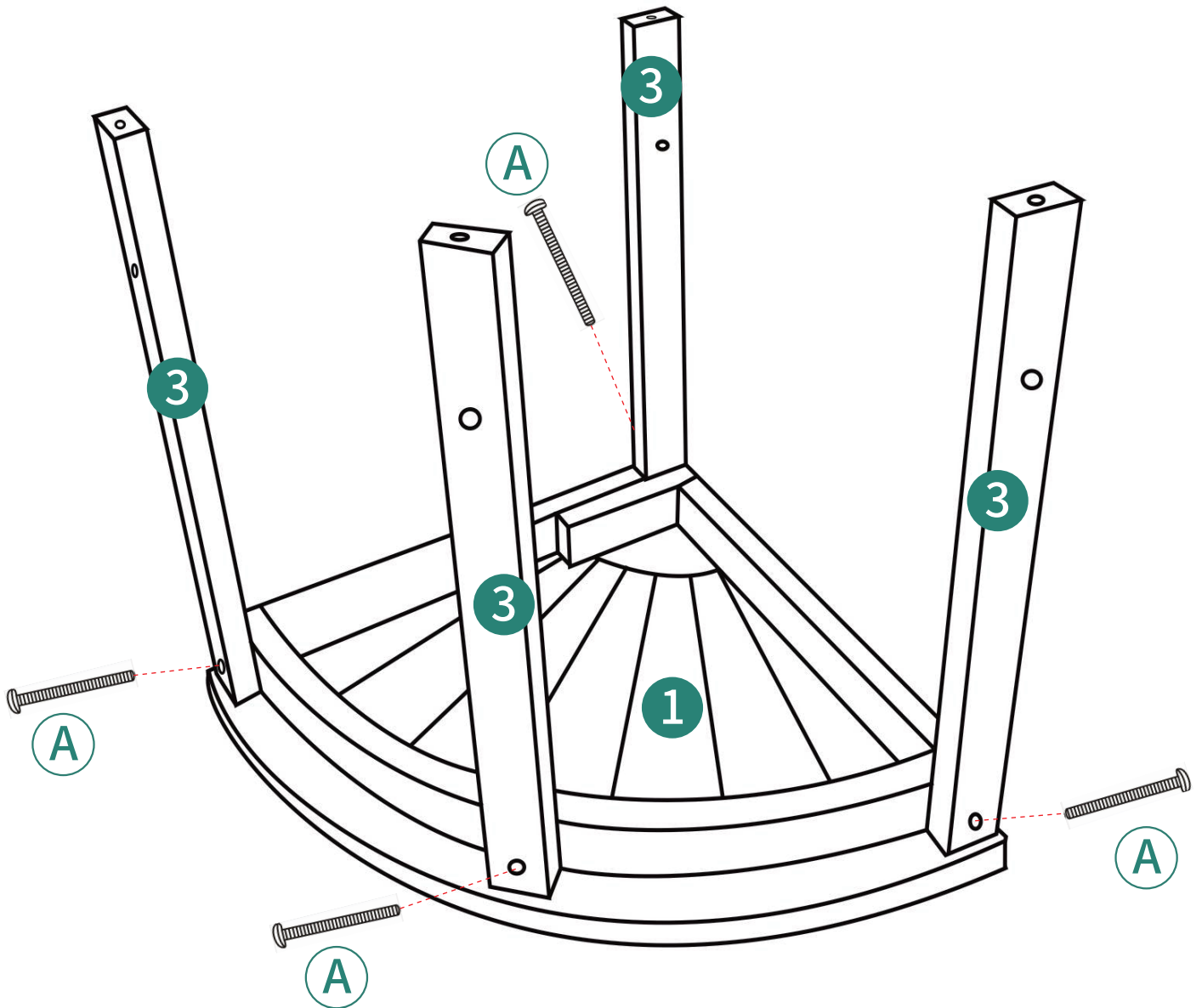

2

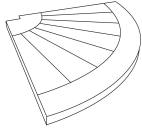

② 1pc



Ⓑ 4pcs

M6 X 35mm



Ⓐ 4pcs

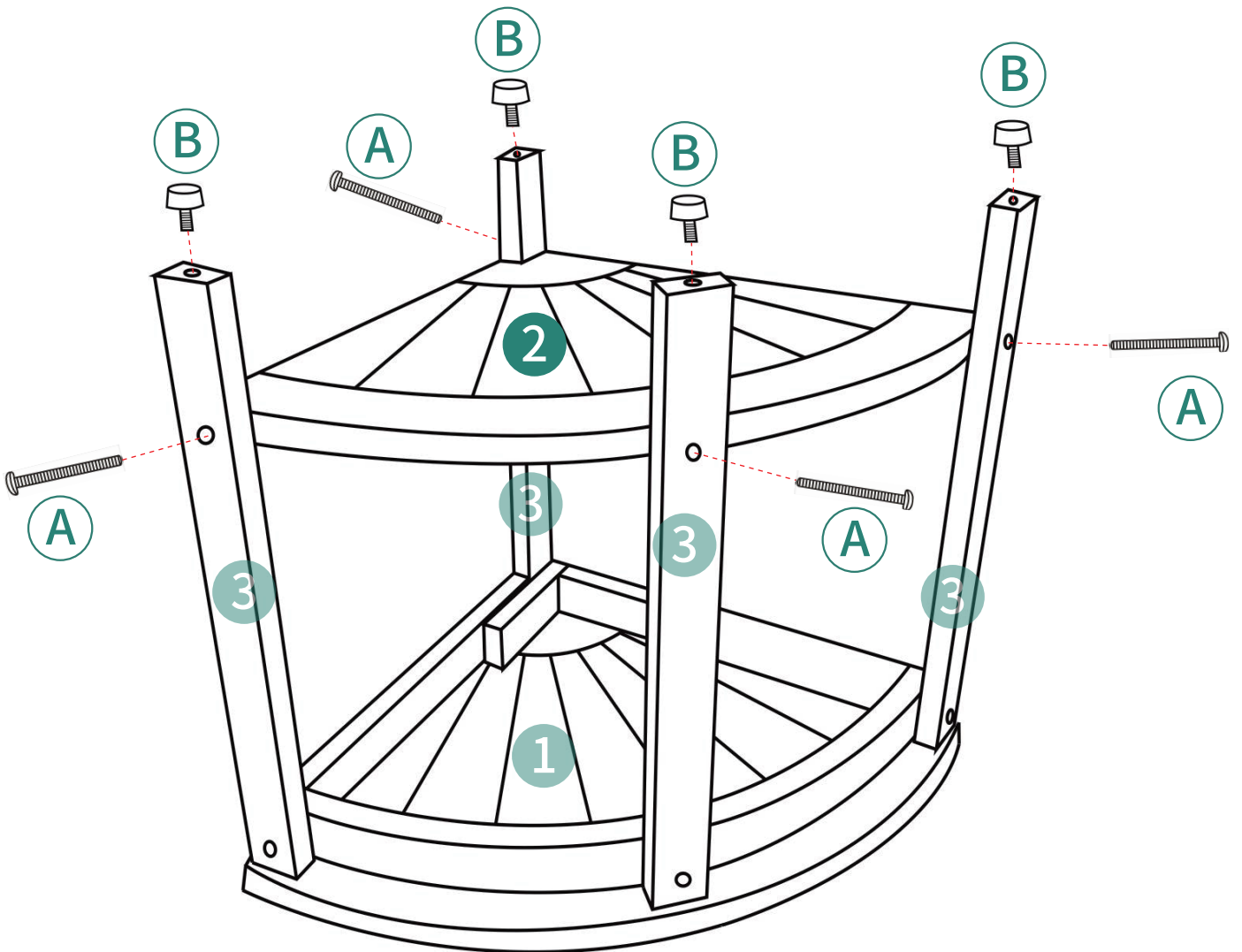

3

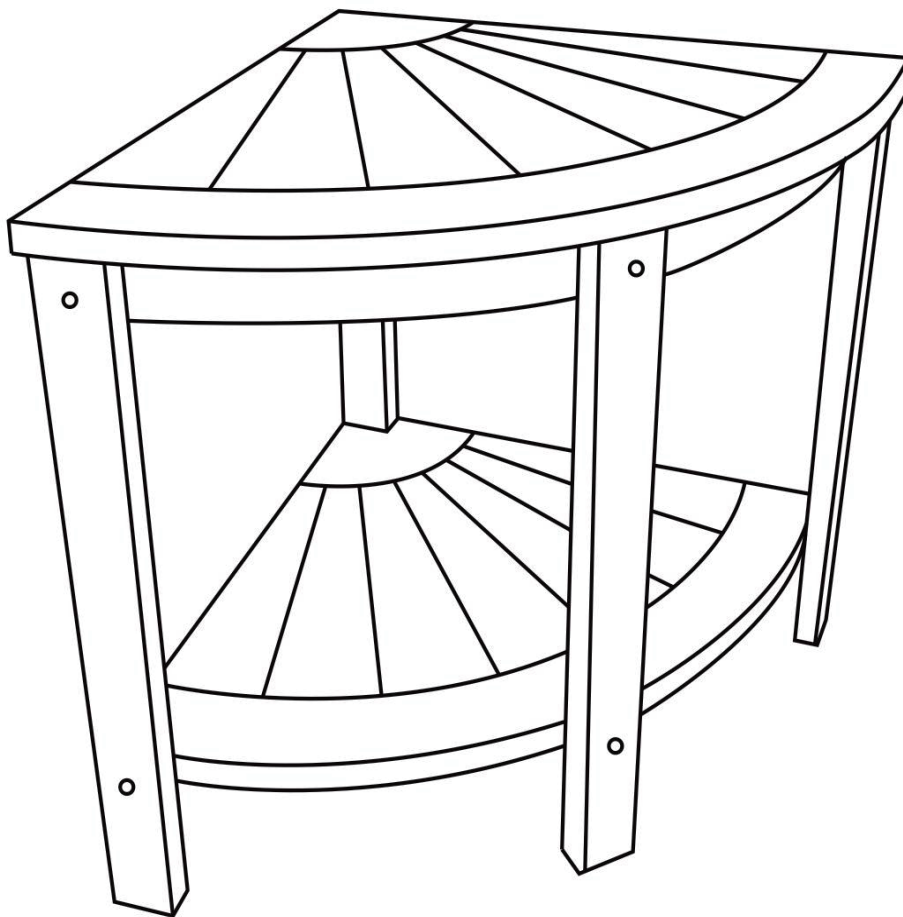

Installation Completed

Installation Abgeschlossen

Installation Complétée

Installazione Completata

Instalación Completada

# HELP CENTER



Inquiry



Assembly issue



Missing parts

If you encounter any difficulties during assembly, please contact us.

Wenn Sie während der Montage auf Schwierigkeiten stoßen, kontaktieren Sie uns bitte.

Si vous rencontrez des difficultés lors du montage, veuillez nous contacter.

Se incontri difficoltà durante il montaggio, ti preghiamo di contattarci.

Si encuentras alguna dificultad durante el ensamblaje, por favor contáctanos.

# DISCLAIMER

Manufacturer and seller expressly disclaim any and all liability for personal injury, property damage or loss, whether direct, indirect, or incidental, resulting from the incorrect attachment, improper use, inadequate maintenance, unapproved modification, or neglect of this product.

Der Hersteller und Verkäufer lehnen ausdrücklich jegliche Haftung für Personenschäden, Sachschäden oder Verluste ab, egal ob direkt, indirekt oder zufällig, die durch falsche Anbringung, unsachgemäßen Gebrauch, unzureichende Wartung, nicht genehmigte Änderungen oder Vernachlässigung dieses Produkts entstehen.

El fabricante y vendedor renuncian expresamente a toda responsabilidad por lesiones personales, daños materiales o pérdidas, ya sean directos, indirectos o incidentales, derivados de la incorrecta colocación, uso inadecuado, mantenimiento insuficiente, modificación no aprobada o negligencia de este producto.

Il produttore e il venditore declinano espressamente ogni responsabilità per lesioni personali, danni materiali o perdite, dirette, indirette o incidentali, derivanti dall'errato fissaggio, uso improprio, manutenzione inadeguata, modifica non autorizzata o negligenza di questo prodotto.

Le fabricant et le vendeur déclinent expressément toute responsabilité en cas de blessures corporelles, de dommages matériels ou de pertes, qu'ils soient directs, indirects ou accessoires, résultant de la fixation incorrecte, de l'utilisation inappropriée, de l'entretien insuffisant, de la modification non approuvée ou de la négligence de ce produit.