

ASSEMBLY INSTRUCTIONS & PARTS IDENTIFICATION SOFA TABLE

Hardware Kit

Ltr	Q'ty	Description	Size
A	1 pc	Allen wrench	4mm
B	8 pcs	Bolt	1/4"Dia*2"
C	8 pcs	Lock washer	1/4"Dia
D	8 pcs	Flat washer	1/4"Dia*3/4"
E	8 pcs	Screw	#8*1-1/2"

Part List

No.	Parts	Description	Q'ty
①	a	Leg	4 pcs
②	b	Shelf	2 pcs
③	c	Storage Box	1 pc
④	d	Drawer	2 pcs
⑤	e	Floor Glide	4 pcs
⑥	f	Knobs/Screws	2 sets
⑦	g	Drawer Stopper	2 pcs
⑧	h	Drawer Glide	2 pcs
⑨	j	Drawer support	2 pcs
⑩	k	Anti Tip Kit	1set

STEP 3: ▼

Insert the two shelves between the three legs and attach the fourth leg with a bolt, lock washer and flat washer.

Secure the shelf to the legs using screws(E). Once the shelf is in place fully tighten all bolts and screws.

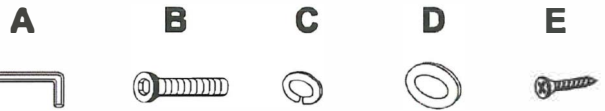
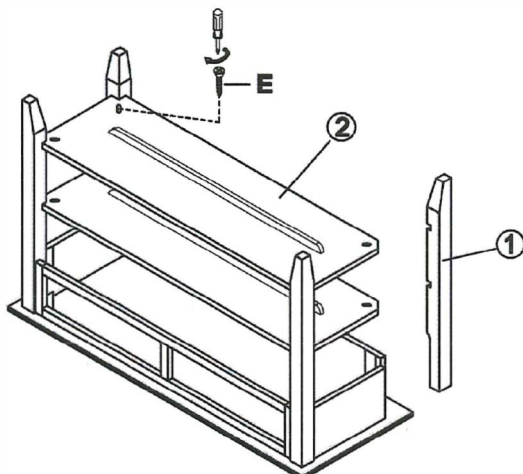

STEP 1: ▼

First pull out the drawer, remove the drawer by pushing down on the plastic drawer stop and gently pulling out the drawer.

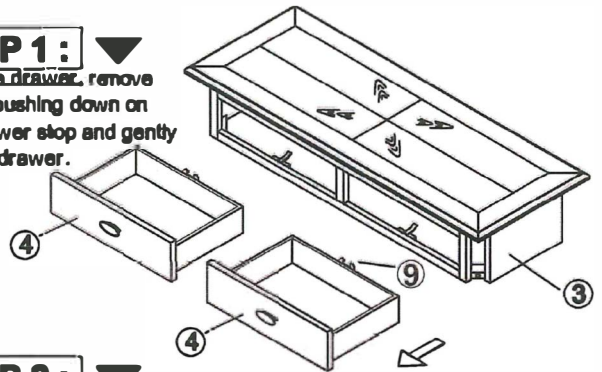

STEP 2: ▼

Carefully place the table top upside-down on a smooth, flat surface to prevent scratches during assembly. Attach three legs to the table top with Allen bolt (B), Lock washer (C) and Flat washer (D), loosely tightening with provided Allen wrench (A). Do not completely tighten bolts at this point.

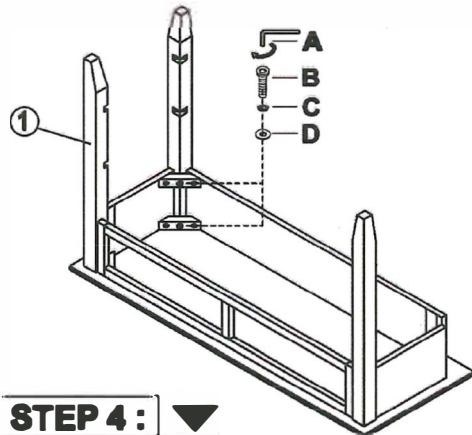

STEP 4: ▼

Carefully turn the assembled table to the upright position. Put back the drawer. Attach the Anti-tip Over restraint. Assembly is now complete.

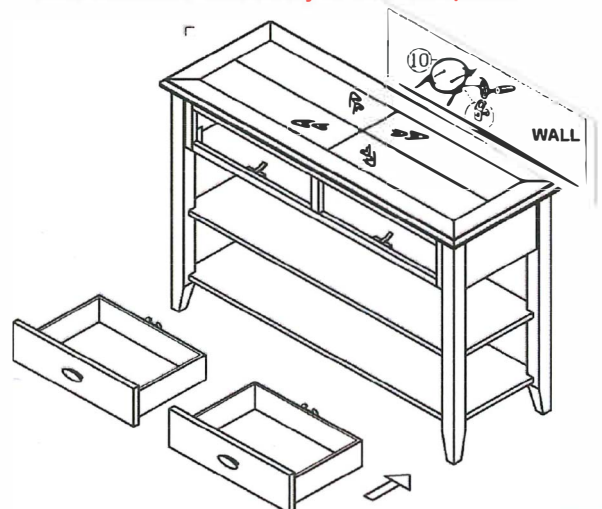

PLEASE NOTE: To help prevent the possibility of tip-over, install the ANTI-TIP OVER restraint provided