

NOTICE

- * Please make sure that you have all parts indicated and they are in good condition before you begin assembly of this item. Refer to part list and hardware list below for guidance.
- * This item should be assembled on a soft surface to prevent scratching the finish during assembly.
- * This item may require periodic tightening.























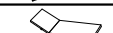



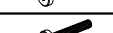

PREPARATION

- * Before beginning assembly of product, make sure all parts are present. Compare parts with part contents list and hardware contents list.
- * If any part is missing or damaged, do not attempt to assemble the product.
- * Estimated Assembly Time: **40 minutes. (Two Person Assembly)**
- * Tools Required for Assembly (included): **Allen Key**

CARE AND MAINTENANCE

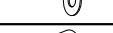
Store outdoor furniture indoors or cover well when not in use. Remove wooden furniture from standing water. Dust regularly with small brush or vacuum. Spills should be taken care of immediately before they harden or stain with a slightly dampened sponge. Do not use bleach solutions

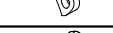
Part List and Hardware List

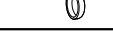
PIECE	DESCRIPTION	PICTURE	QUANTITY	PIECE	DESCRIPTION	PICTURE	QUANTITY
A	Left Seat		1X	P	Right Top Canopy		1X
B	Right Seat		1X	Q	Left Top Canopy		1X
C	Back Rest		2X	R	Support Canopy		2X
D1	Left Long Side		1X	O	Metal Tray		1X
D2	Left Short Side		1X	U	Plastic Tray		2X
E1	Right Long Side		1X	V	Cover		1X
E2	Right Short Side		1X	CSH	Seat Cushion		2X
F	Front Side		1X	HW1	Allen Bolt: M6 x 0.5 x 15 mm		16X
G	Back Side		1X	HW2	Allen Bolt: M6 x 0.5 x 30 mm		32X
H	Middle Leg		2X	HW3	Allen Bolt: M6 x 0.5 x 40 mm		12X
J	Connector		2X	HW4	Allen Bolt: M6 x 0.5 x 55 mm		7X
K	Middle Table 1		1X	HW5	Flat washer: M6 x 1 mm		51X
L	Middle Table 2		1X	HW6	Curve cover		4X
M	Support Bar		2X	HW7	Plastic cover		8X
N	Foot Canopy		2X	HW8	Allen Key		2X

Product Dimensions

59.05"W x 78.74"D x 61.81"H (Daybed)

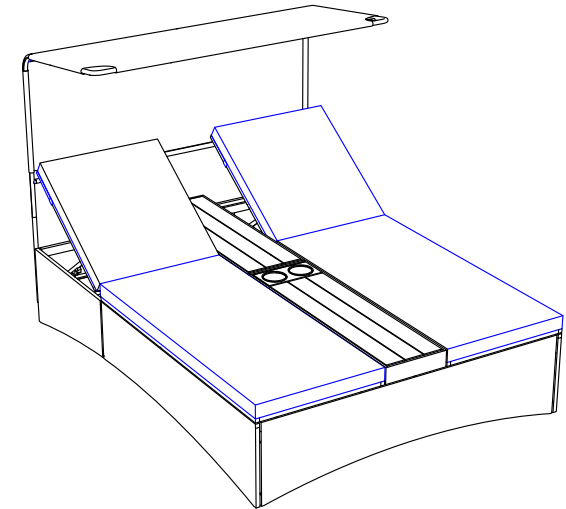

Weight Capacity : 352 lbs (Single Seat)

Warning : Do not stand on Daybed

Warning : Do not over torque bolts/screws

PREPARATION

- * Before beginning assembly of product, make sure all parts are present. Compare parts with part contents list and hardware contents list.
- * If any part is missing or damaged, do not attempt to assemble the product.
- * Estimated Assembly Time: 40 minutes (Two Person Assembly)
- * Tools Required for Assembly (included): Allen Key.
- * If you are having difficulty, our friendly Customer Care team is always here to help. Please email customersupport@safavieh.com

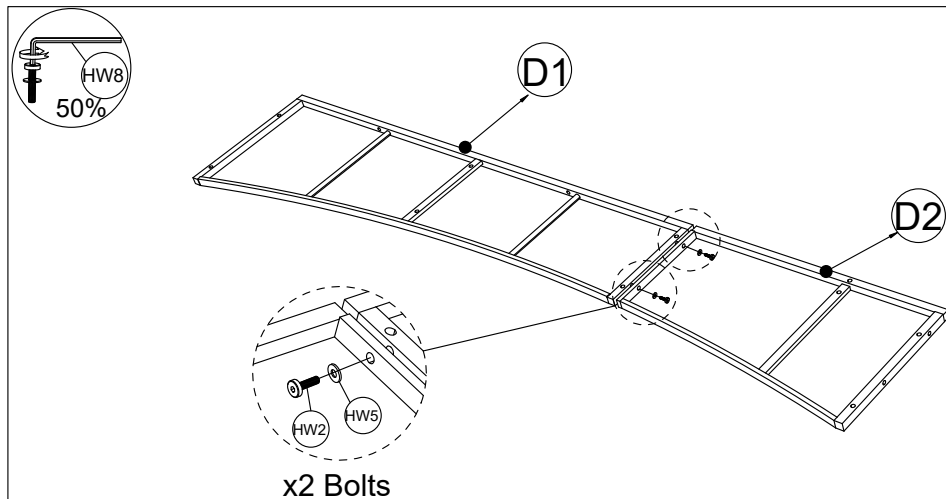

STEP 1: Connect Left Long Side (D1) & Left Short Side (D2), tighten Bolt (HW2) & Flat washer (HW5) with Allen Key (HW8).

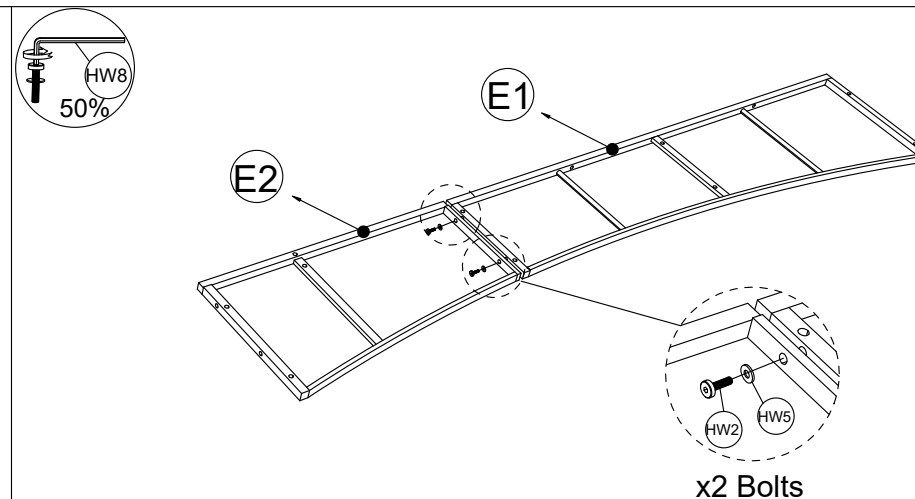

STEP 2: Connect Right Long Side (E1) & Right Short Side (E2), tighten Bolt (HW2) Flat washer (HW5) with Allen Key (HW8).

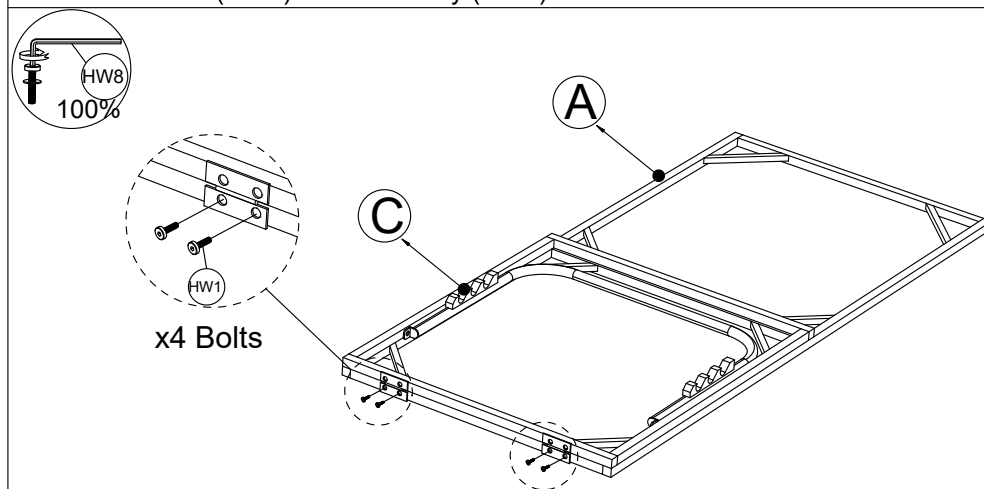

STEP 3: Connect Left Seat (A) & Back Rest (C), tighten Bolt (HW1), with Allen Key (HW8).

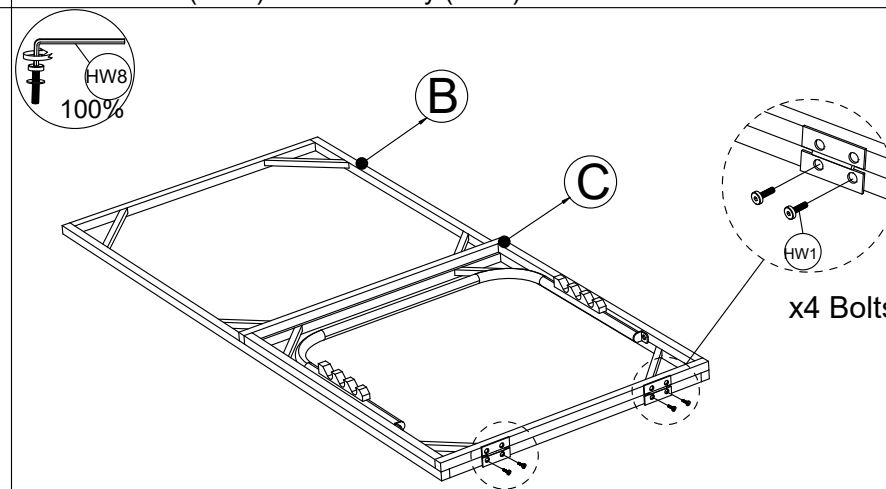

STEP 4: Connect Right Seat (B) & Back Rest (C), tighten Bolt (HW1), with Allen Key (HW8).

PREPARATION

* Before beginning assembly of product, make sure all parts are present. Compare parts with part contents list and hardware contents list.

* If any part is missing or damaged, do not attempt to assemble the product.

* Estimated Assembly Time: 40 minutes. (Two Person Assembly)

* Tools Required for Assembly (included): Allen Key.

* If you are having difficulty, our friendly Customer Care team is always here to help. Please email customersupport@safavieh.com

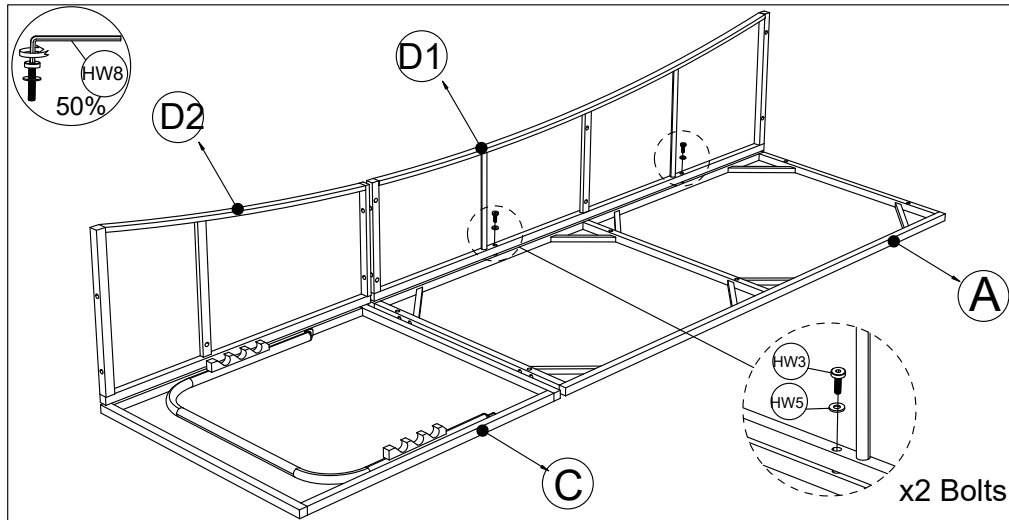

STEP 5: Connect the part from step 1 & the part from step 3, tighten Bolt (HW3), Flat washer (HW5) with Allen Key (HW8).

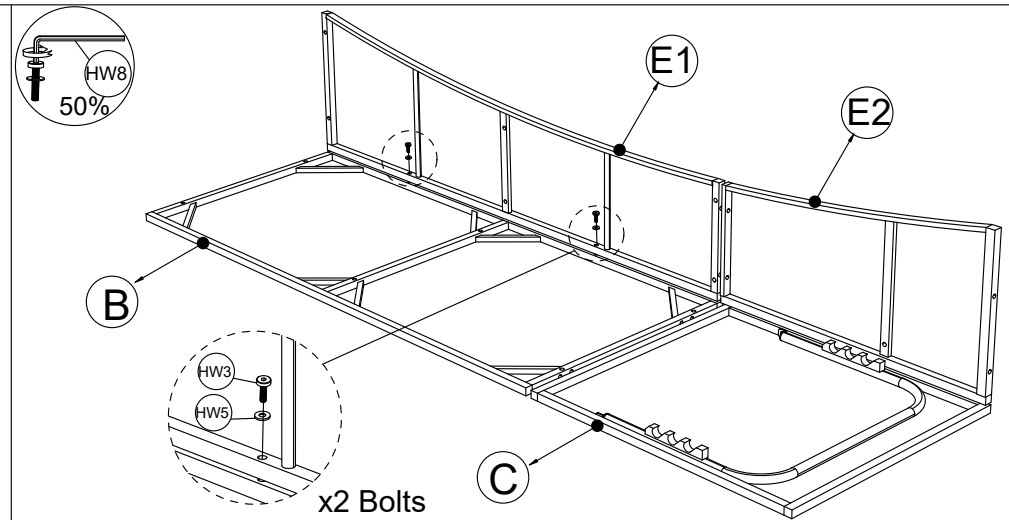

STEP 6: Connect the part from step 2 & the part from step 4, tighten Bolt (HW3), Flat washer (HW5) with Allen Key (HW8).

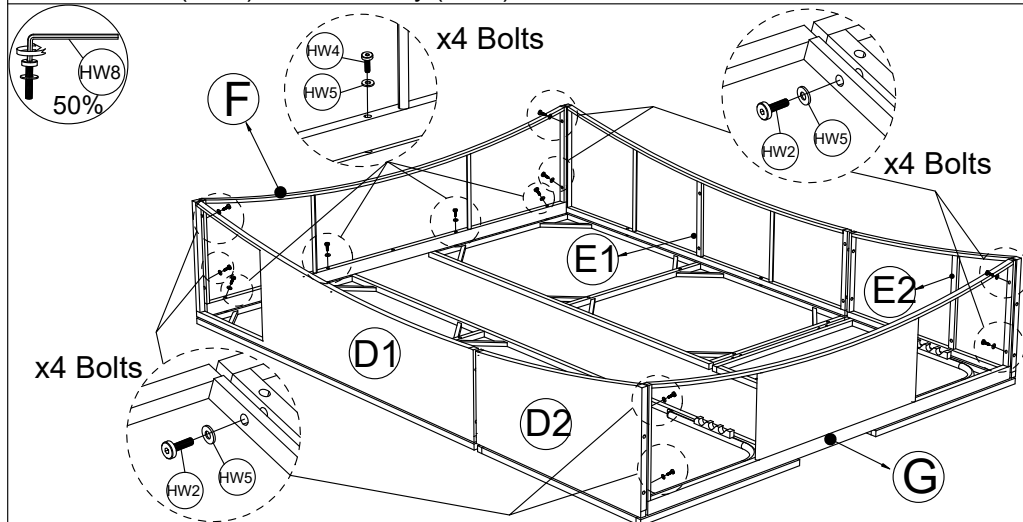

STEP 7: Connect the part from step 5 & step 6, & Front Side (F), Back Side (G), tighten Bolt (HW2), Bolt (HW4), Flat Washer (HW5) with Allen Key (HW8).

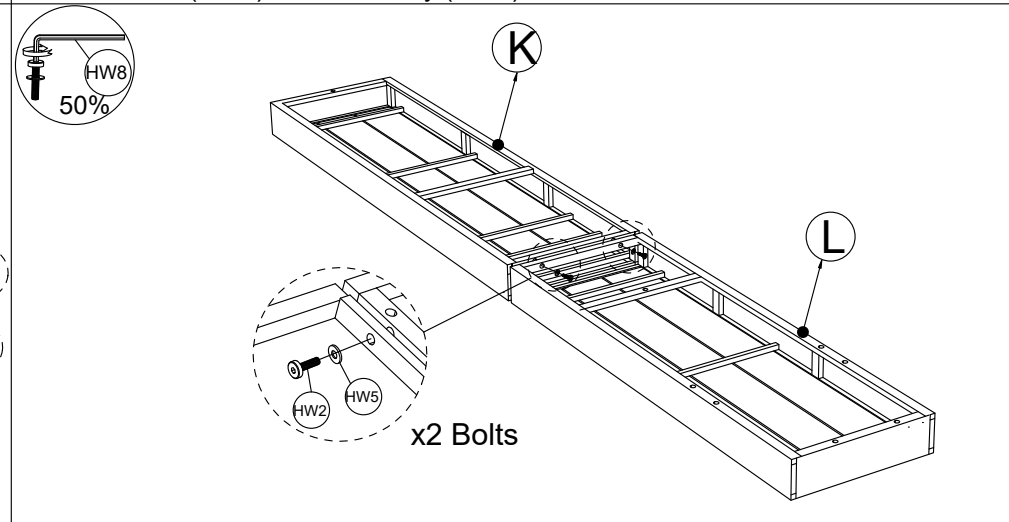

STEP 8: Connect Middle Table 1 (K) & Middle Table 2 (L), tighten Bolt (HW2), Flat Washer (HW5) with Allen Key (HW8).

PREPARATION

- * Before beginning assembly of product, make sure all parts are present. Compare parts with part contents list and hardware contents list.
- * If any part is missing or damaged, do not attempt to assemble the product.
- * Estimated Assembly Time: 40 minutes (Two Person Assembly)
- * Tools Required for Assembly (included): Allen Key.
- * If you are having difficulty, our friendly Customer Care team is always here to help. Please email customersupport@safavieh.com

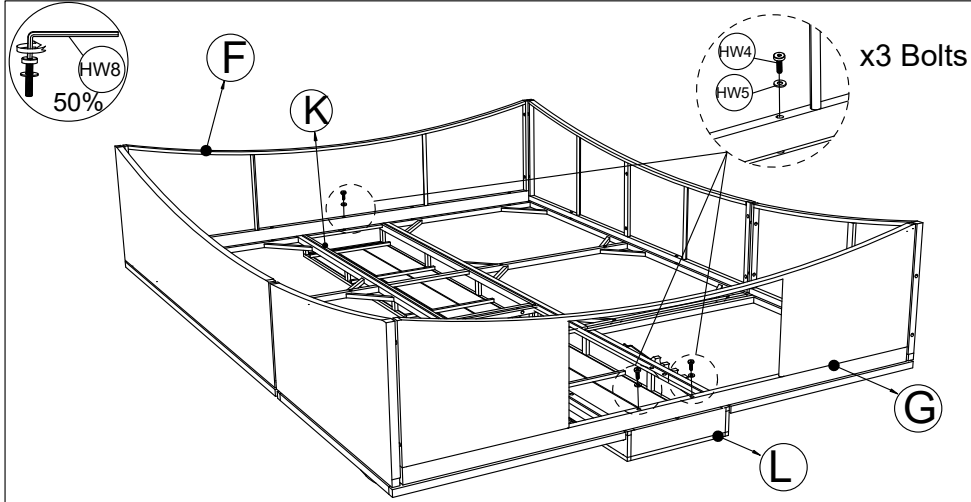

STEP 9: Connect the part from step 7 & the part from step 8, tighten Bolt (HW4), Flat washer (HW5) with Allen Key (HW8).

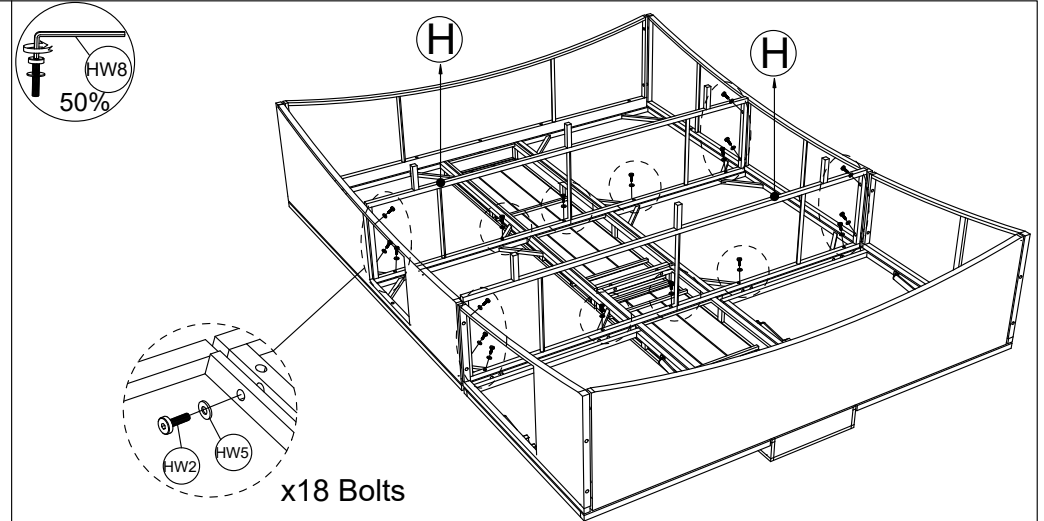

STEP 10: Connect the part from step 9 & Middle Leg (H), tighten Bolt (HW2), Flat washer (HW5) with Allen Key (HW8).

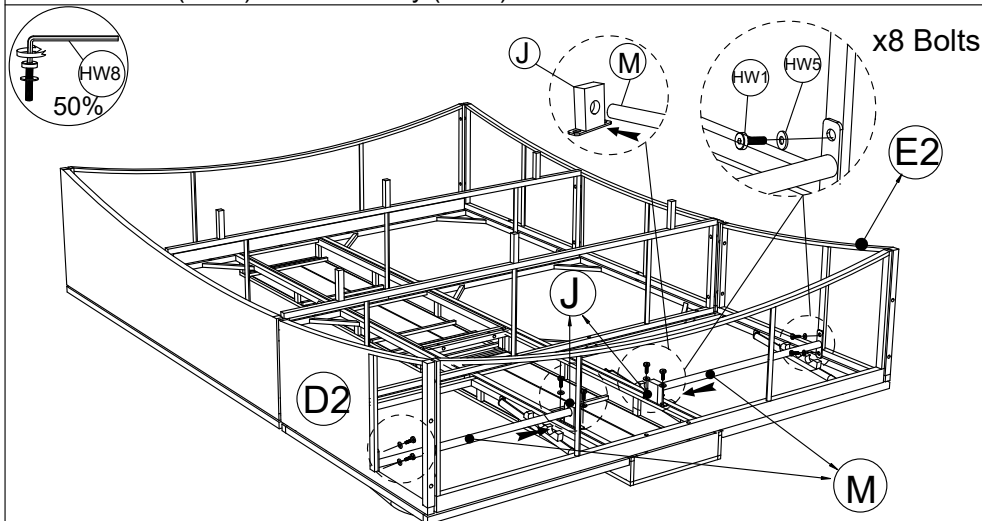

STEP 11: Connect the part from step 10 & Support Bar (M), Connector (J), tighten Bolt (HW1) Flat Washer (HW5) with Allen Key (HW8).

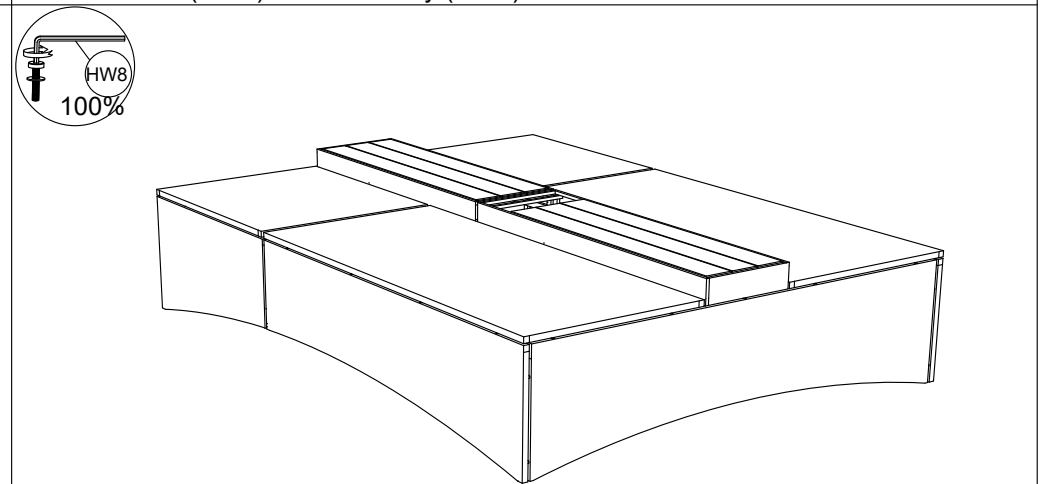

STEP 12: Put the part from step 11 upright, Tighten the Bolts with Allen Key (HW8).

PREPARATION

- * Before beginning assembly of product, make sure all parts are present. Compare parts with part contents list and hardware contents list.
- * If any part is missing or damaged, do not attempt to assemble the product.
- * Estimated Assembly Time: 40 minutes (Two Person Assembly)
- * Tools Required for Assembly (included): Allen Key.
- * If you are having difficulty, our friendly Customer Care team is always here to help. Please email customersupport@safavieh.com

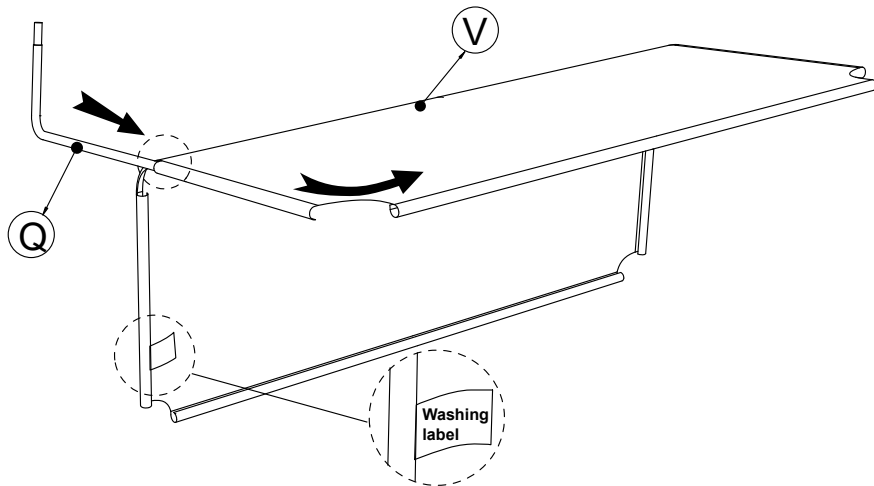

STEP 13: Put the Cover (V) is right by set washing label in front.
Connect Left Top Canopy (Q) with Cover (V)

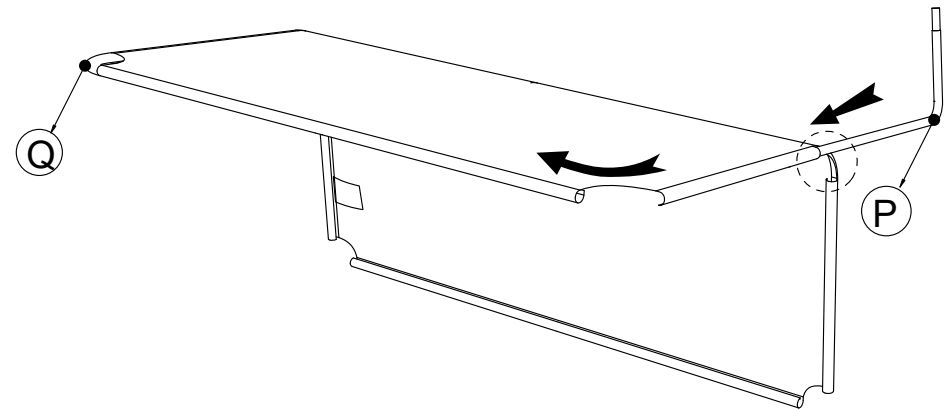

STEP 14: Connect the part from step 13 & Right Top Canopy (P).

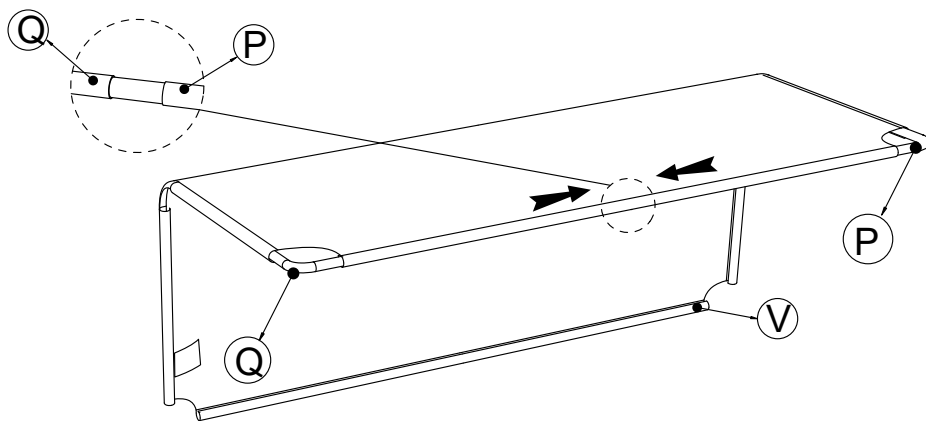

STEP 15: Connect Left Top Canopy (Q) & Right Top Canopy (P).

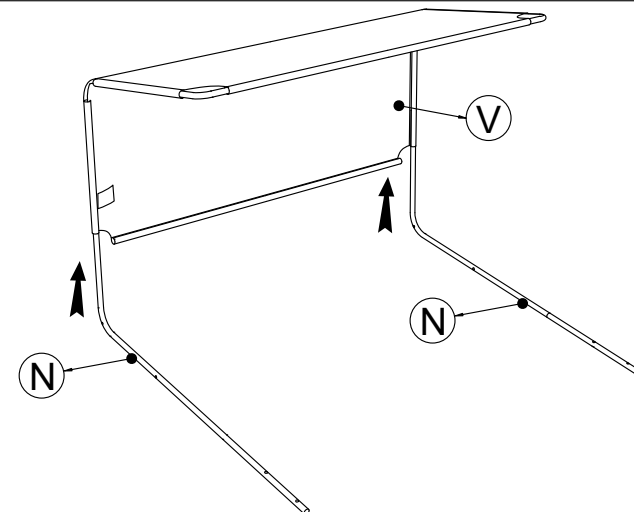

STEP 16: Connect the part from step 15 & Foot Canopy (N).

PREPARATION

- * Before beginning assembly of product, make sure all parts are present. Compare parts with part contents list and hardware contents list.
- * If any part is missing or damaged, do not attempt to assemble the product.
- * Estimated Assembly Time: 40 minutes (Two Person Assembly)
- * Tools Required for Assembly (included): Allen Key.
- * If you are having difficulty, our friendly Customer Care team is always here to help. Please email customersupport@safavieh.com

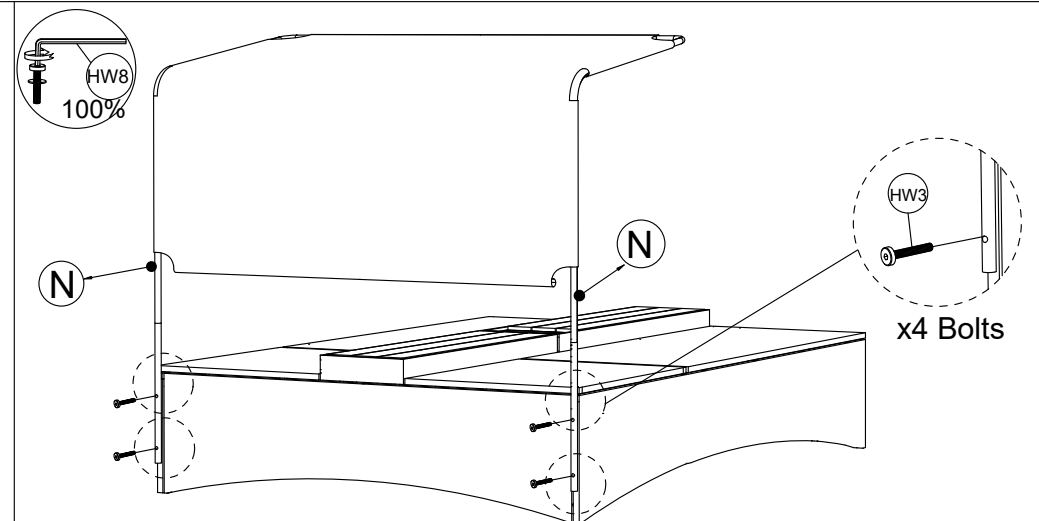
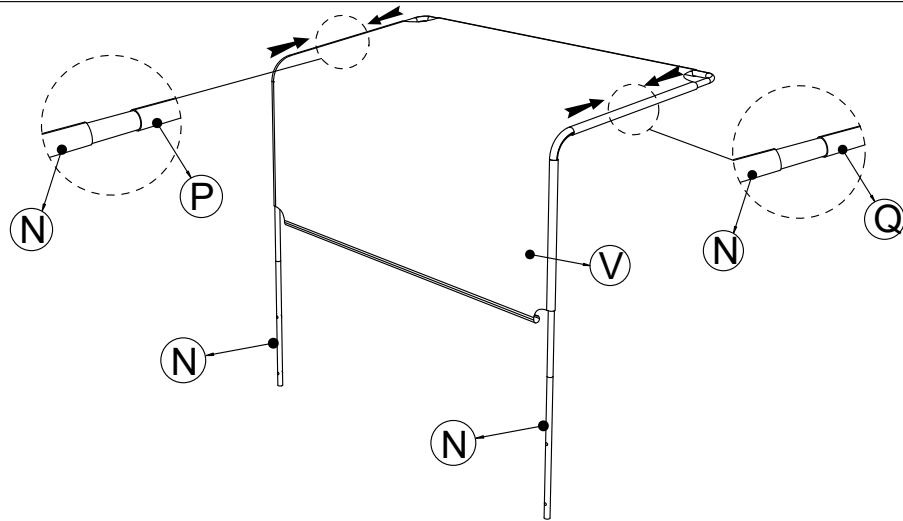

STEP 17: Connect the part from step 16 & Left Top Canopy (Q), Right Top Canopy (P).

STEP 18: Connect the part from step 17 & the part from step 12, tighten Bolt (HW3) with Allen Key (HW8).

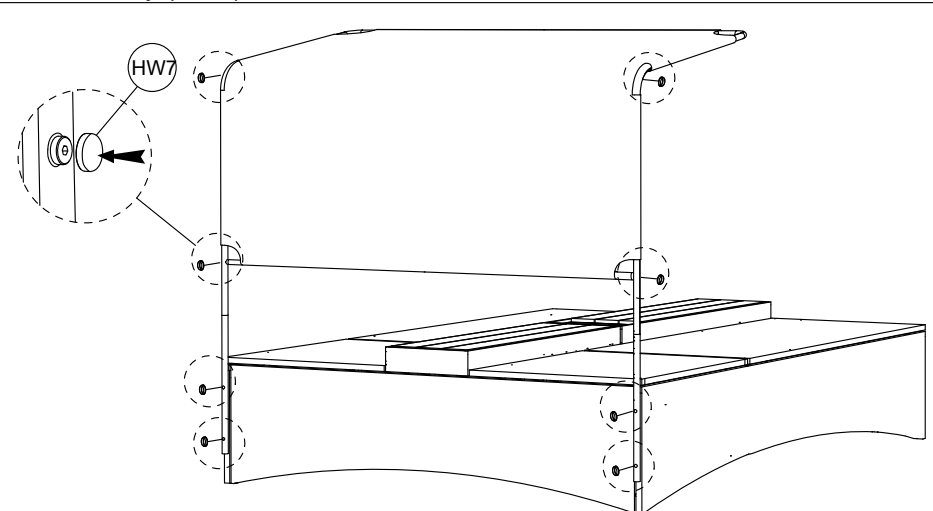
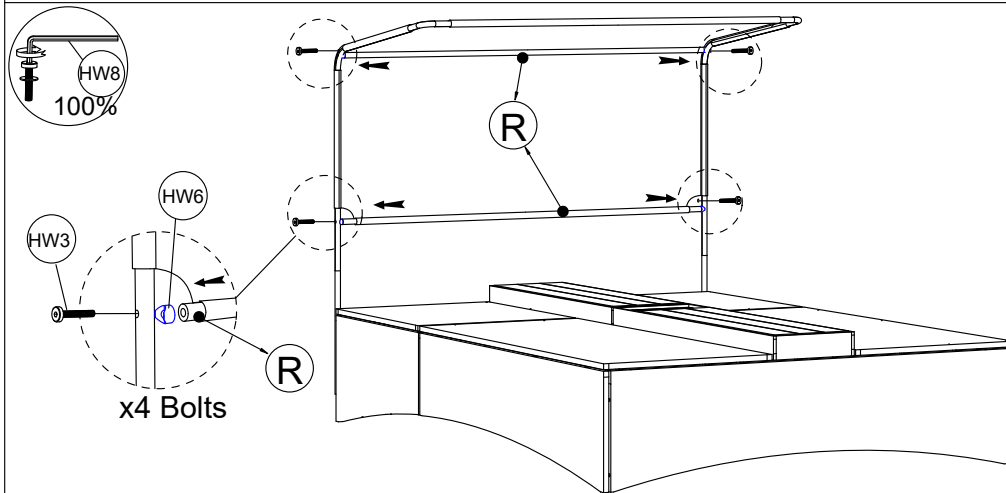

STEP 19: Connect the part from step 18 & Support Canopy (R), tighten Bolt (HW3) Curve Washer M6 (HW6), with Allen Key (HW8).

STEP 20: Tighten the Bolts with Allen Key (HW8), Push the plastic bolt cover (HW7).

PREPARATION

- * Before beginning assembly of product, make sure all parts are present. Compare parts with part contents list and hardware contents list.
- * If any part is missing or damaged, do not attempt to assemble the product.
- * Estimated Assembly Time: 40 minutes (Two Person Assembly)
- * Tools Required for Assembly (included): Allen Key.
- * If you are having difficulty, our friendly Customer Care team is always here to help. Please email customersupport@safavieh.com

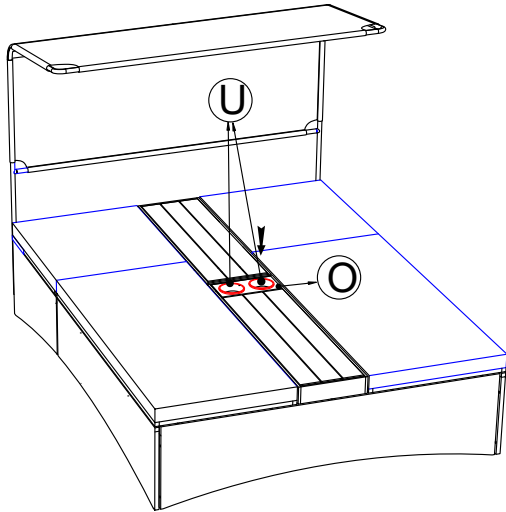

STEP 21: Set up Metal Tray (U), Plastic Tray (O).

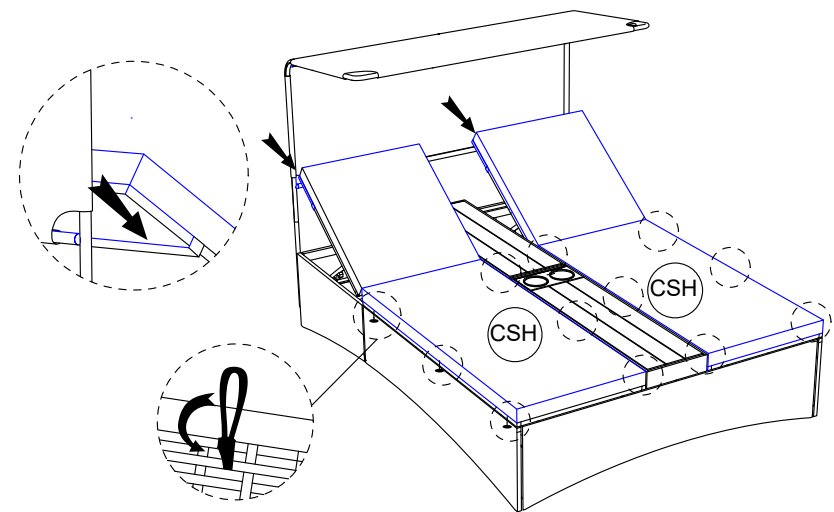

STEP 22: Set up Seat Cushion (CSH)

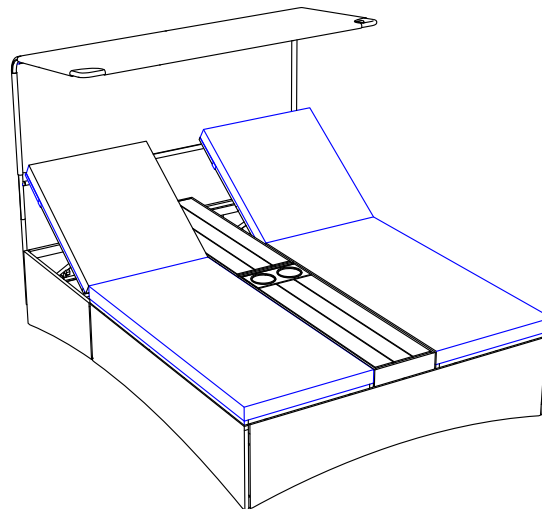

STEP 23: Finish Adora Double Daybed