

1870100553A1

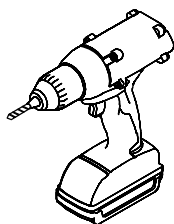
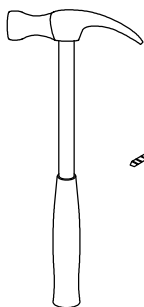
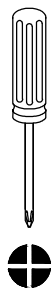
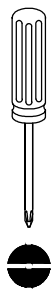
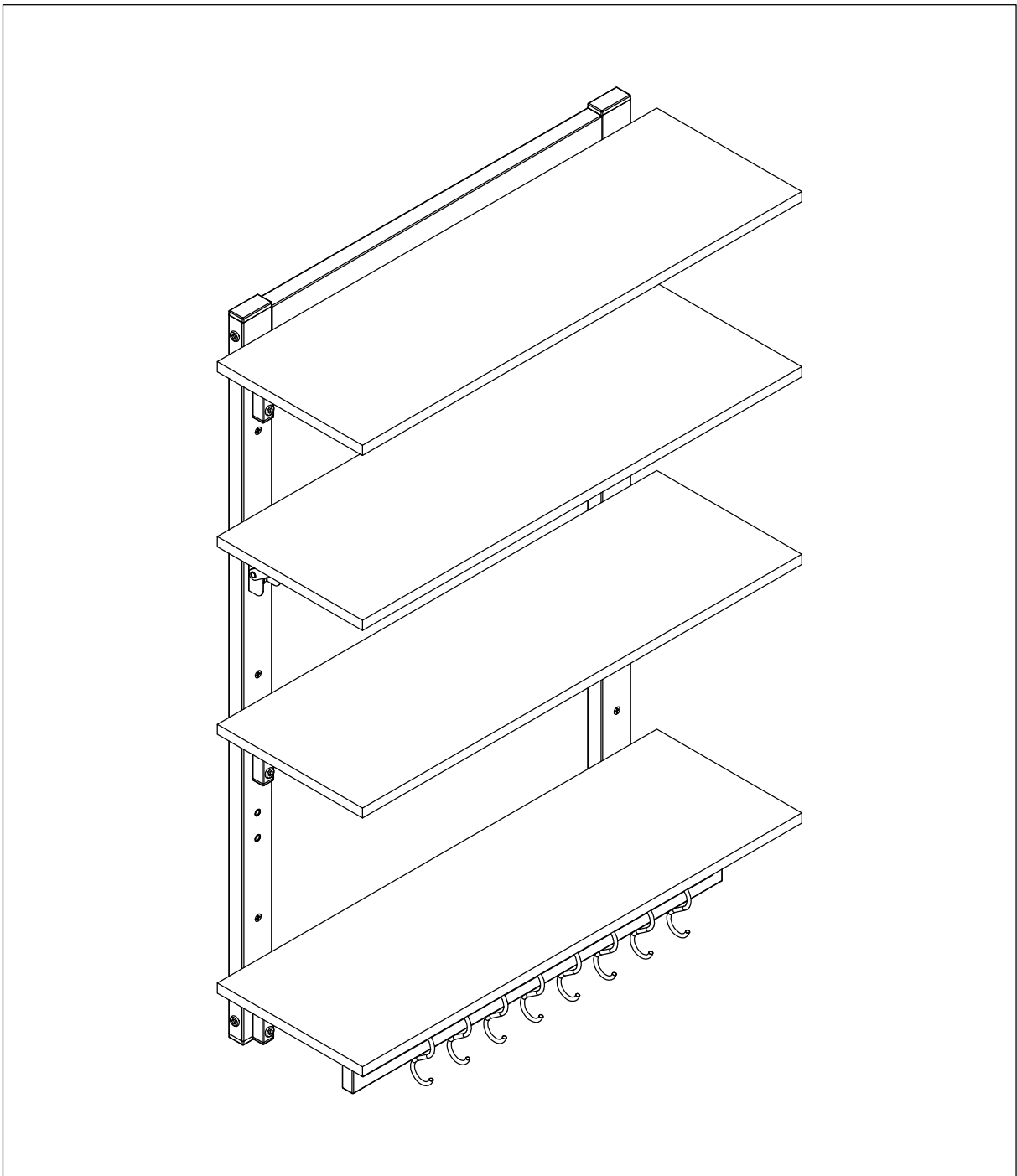

**Tools required
(not included)**

1 people for assembly

Notes:

1. ASSEMBLY PREPARATION AND TIPS FOR ASSEMBLY

- 1). Remove all packaging materials, staples and packing straps from the carton.
- 2). Refer to Parts List and Hardware List, and ensure parts and hardware are correct before assembly.
Contact customer service for missing parts.
- 3). Place all wooden parts on a clean, flat and soft surface (e.g. carpet or rug) to prevent scratch and damage to parts.
- 4). Allow ample room for assembly and assemble the product near where the product will be placed.
- 5). During assembly, do not over-tighten any fittings as this may cause damage.
- 6). Always place the product on a flat, level surface.

2. CARE AND MAINTENANCE

- 1). KEEP ALL HARDWARE PARTS OUT OF REACH OF CHILDREN.
- 2). Wipe clean with a soft, dry cloth; avoid the use of harsh chemicals or household cleaners as they may damage the exterior finish of the furniture.
- 3). Hardware may loosen over time. Periodically, check that all connections are tight; re-tighten as necessary.

3. TIPS TO PROTECT & CARE FOR YOUR FURNITURE

- 1). Avoid placing your furniture in direct sunlight, as sunlight causes fading.
- 2). Use a protective pad when writing on the furniture surface.
- 3). Use cutting boards and trivets for food preparation in order to avoid damaging the top for the unit.



1-Person Assembly



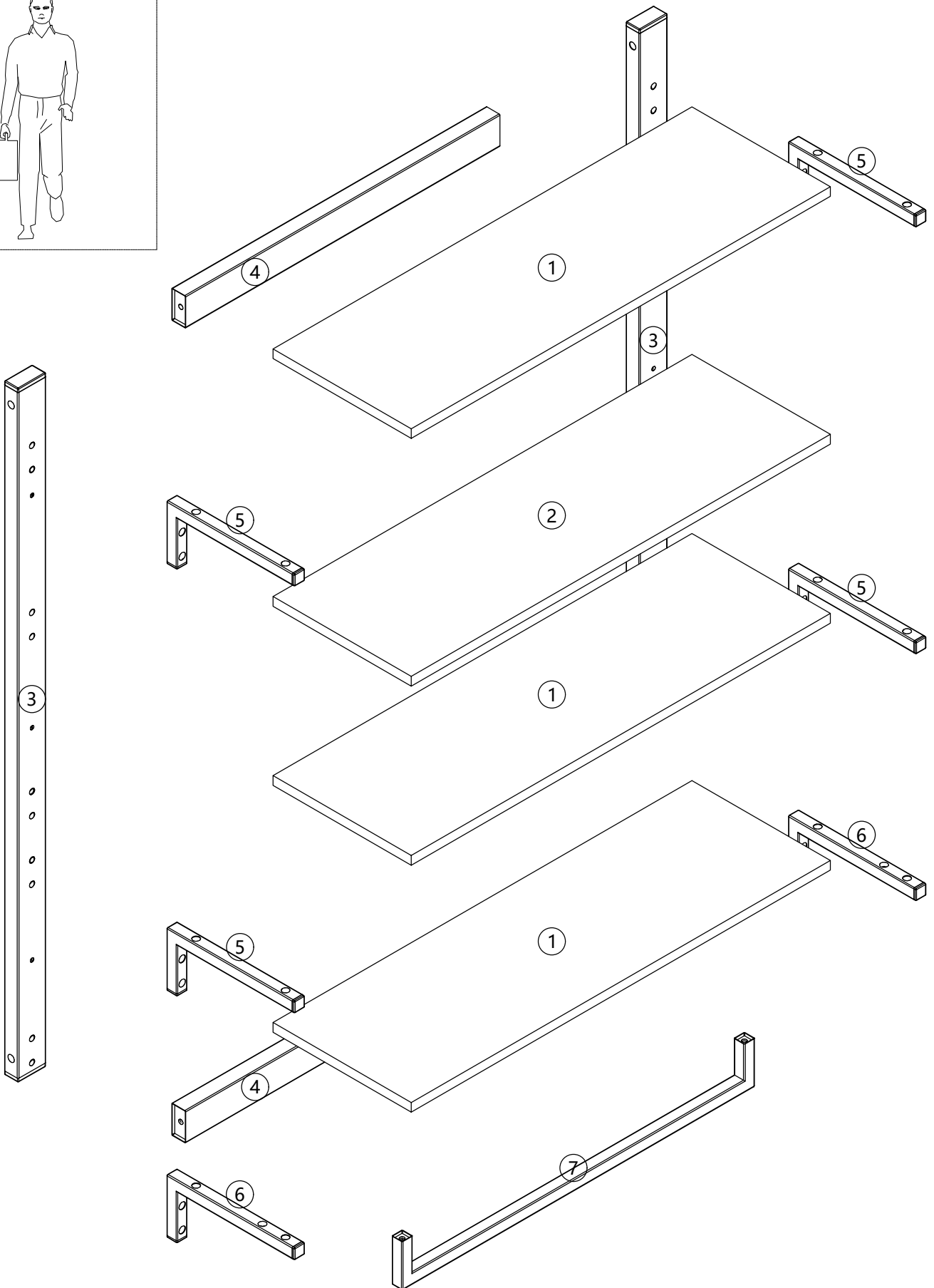

ASSEMBLY OVERVIEW

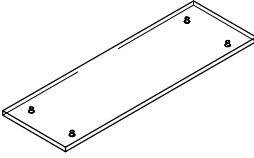
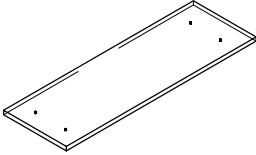

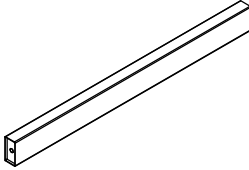
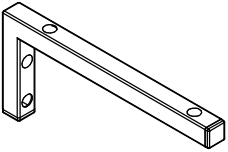
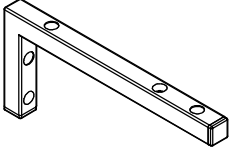
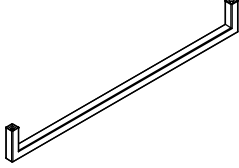
PART LIST

<p>① X3 PCS</p> 	<p>② X1 PCS</p> 	<p>③ X2 PCS</p> 	<p>④ X2 PCS</p> 	<p>⑤ X4 PCS</p> 
<p>⑥ X2 PCS</p> 	<p>⑦ X1 PCS</p> 			

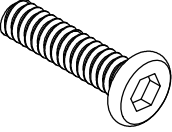
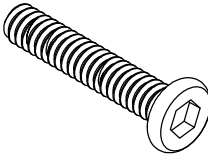
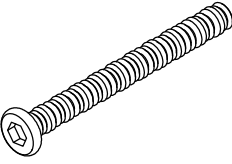
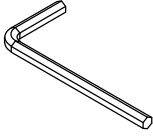
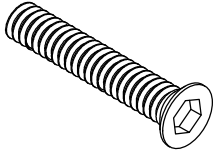
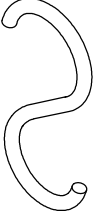
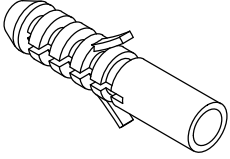
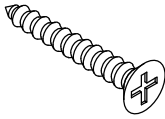
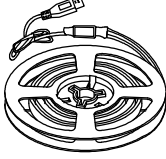
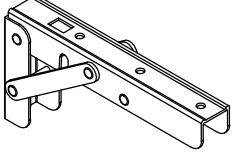
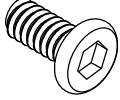
HARDWARE LIST

<p>A</p>  <p>M6*23</p>	<p>B</p>  <p>M6*30</p>	<p>C</p>  <p>M6*60</p>	<p>D</p>  <p>S4</p>	<p>E</p>  <p>M6*28</p>
<p>12 PCS (Extra 2)</p>	<p>12 PCS (Extra 2)</p>	<p>4 PCS (Extra 1)</p>	<p>1 PCS</p>	<p>2 PCS</p>
<p>F</p> 	<p>G</p>  <p>Ø7*60mm</p>	<p>H</p>  <p>Ø5*60mm</p>	<p>I</p> 	<p>J</p> 
<p>8 PCS</p>	<p>6 PCS (Extra 1)</p>	<p>6 PCS (Extra 1)</p>	<p>1 PCS</p>	<p>2 PCS</p>
<p>K</p>  <p>M6*12mm</p>	<p>L</p>  <p>ST4*12mm</p>	<p>M</p> 		
<p>4 PCS (Extra 1)</p>	<p>4 PCS (Extra 1)</p>	<p>1 PCS</p>		

Instructions For Fastening CAM-BOLT and CAM-LOCK

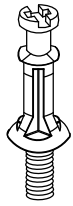

CAM-BOLT



CAM-LOCK

Tools Required

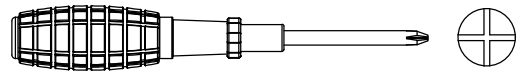

INSERTING AND TIGHTENING CAM-BOLT

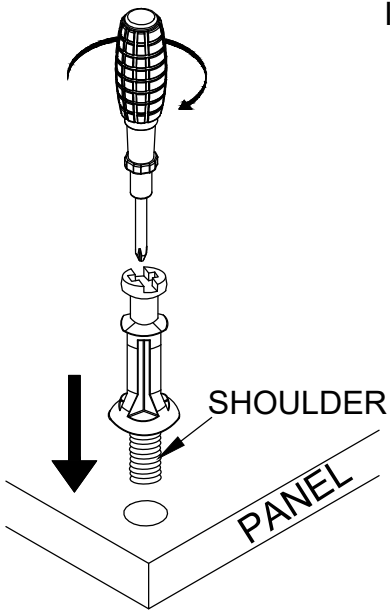

Place Cam-bolt on pre-drilled hole and screw in vertically

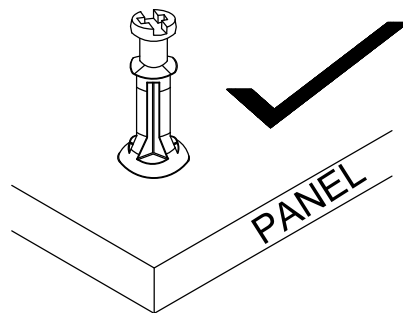

Shoulder is flushed (on the same level) with the panel.

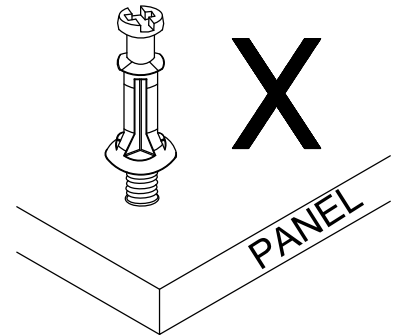

Shoulder is above the panel.

Place Cam-bolt on the designated pre-drilled holes on the panel. Use a Phillips Screwdriver to screw-in Cam-bolt vertically until shoulder is flushed (on the same level) with panel.

INSERTING CAM-LOCK

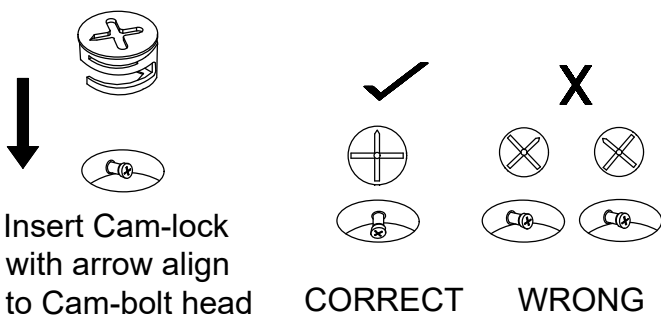

Insert Cam-lock with arrow align to Cam-bolt head

CORRECT

WRONG

Align the arrow on the Cam-lock to the Cam-bolt head and insert the Cam-lock. Ensure Cam-lock is fully inserted.

TIGHTENING CAM-LOCK

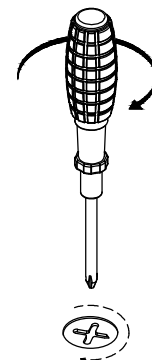

Use a Flat-head Screwdriver to turn Camlock clockwise so it locks onto the head of the Cam-bolt. Turn until it is snug (about 3/4ths of a turn) -- over-tightening could damage Cam-lock or/and Cam-bolt.

Step 1.

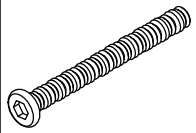

C x2

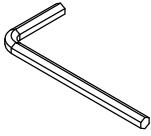

D x1

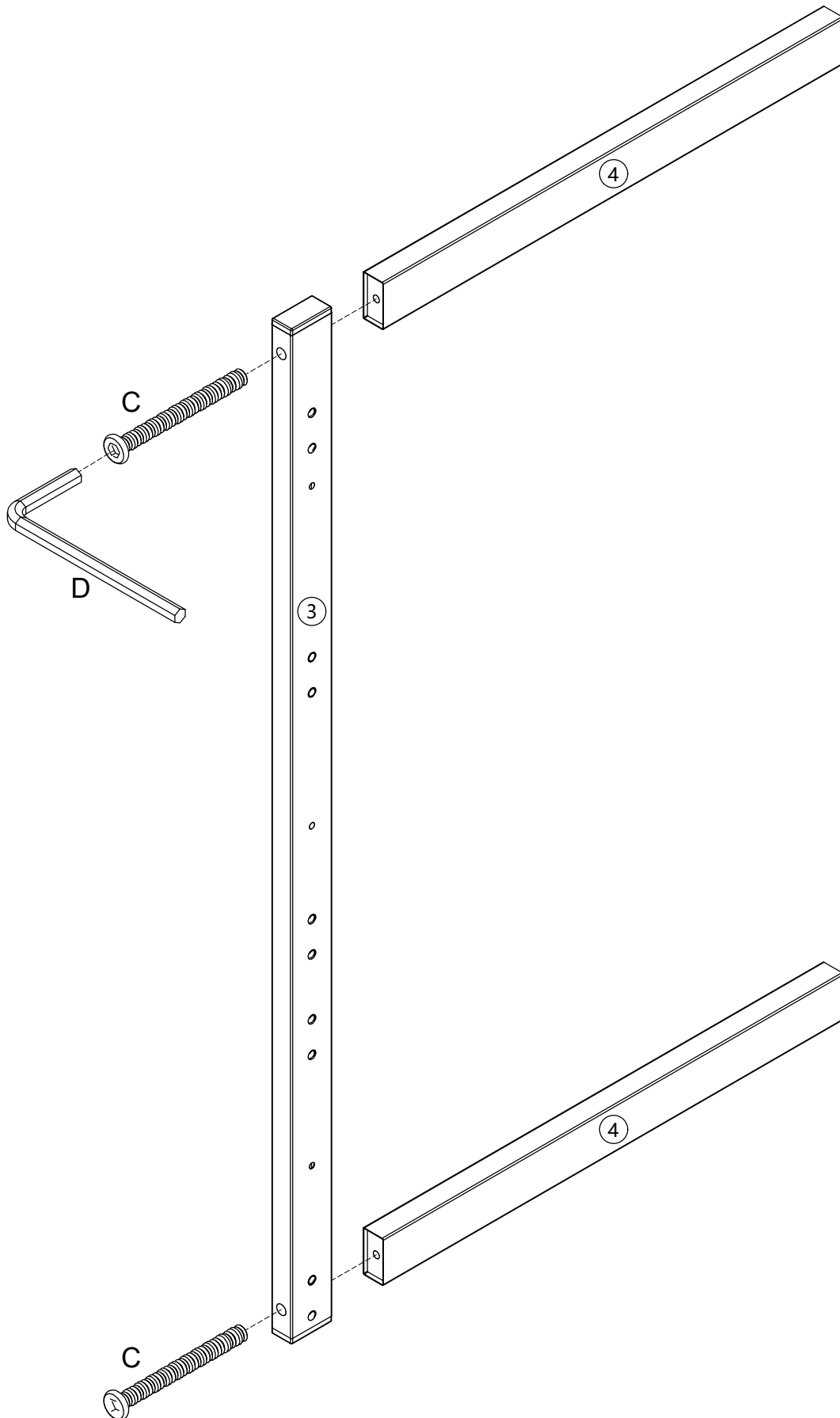

Step 2.

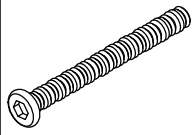

C x2

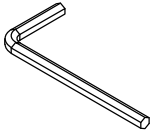

D x1

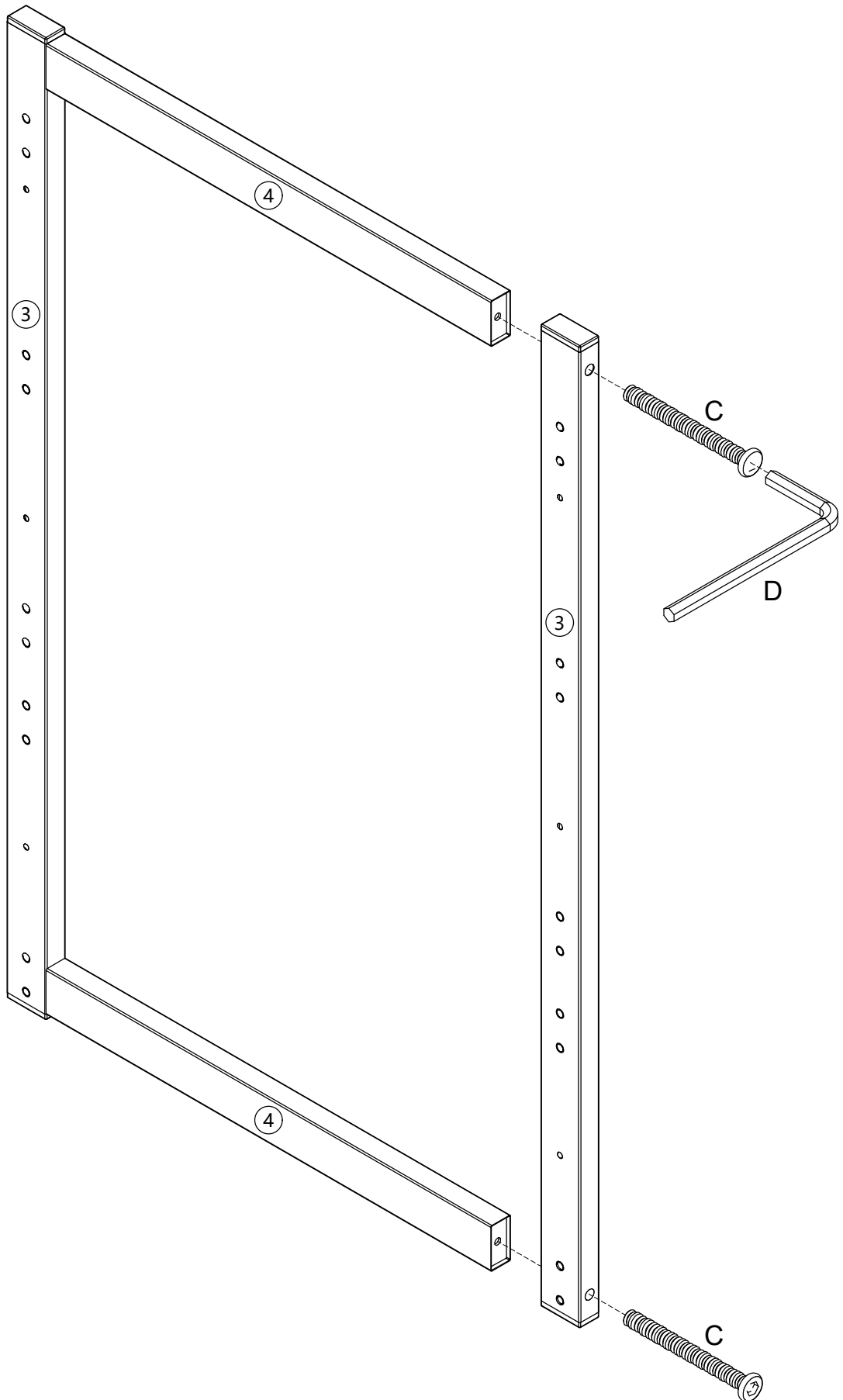

Step 3.

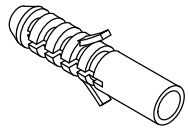

G x6

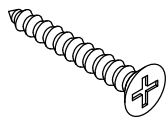

H x6

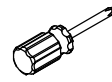
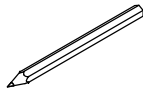

Mx1

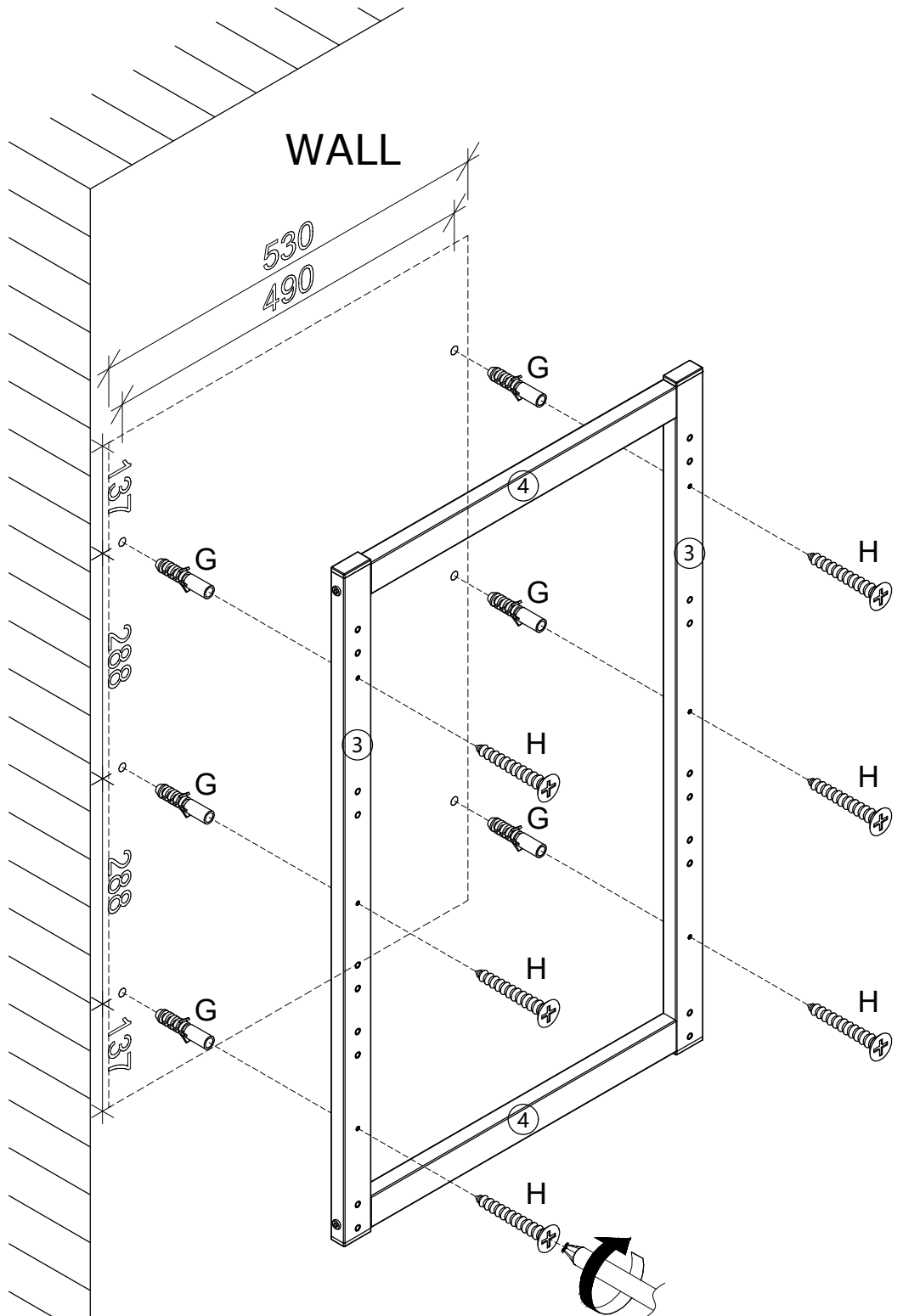
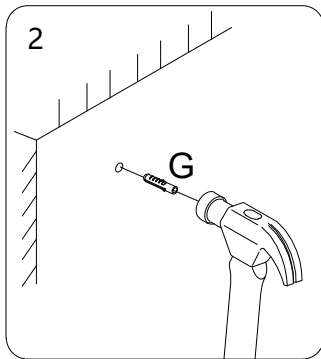
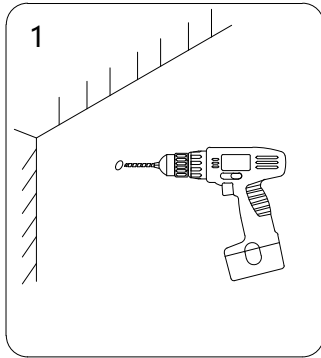

Step 4.

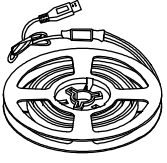

1 x1

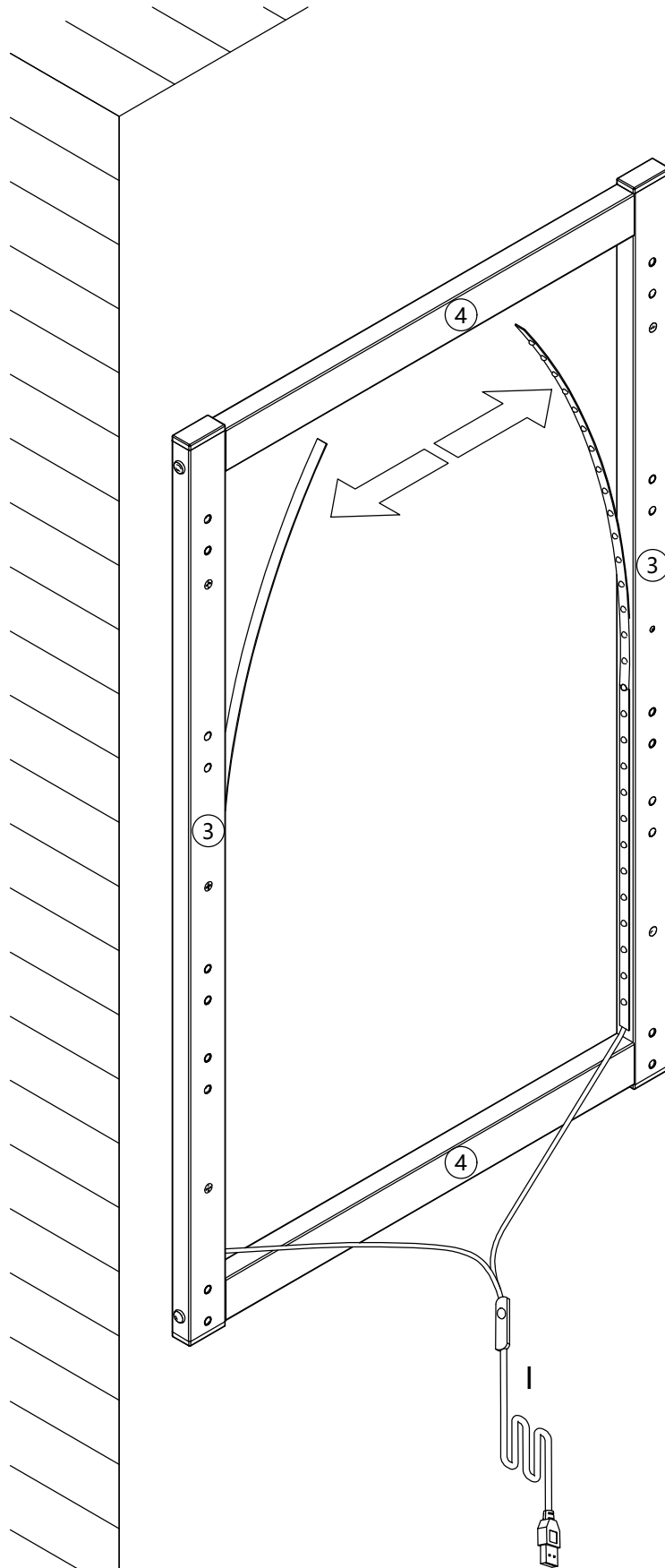

Step 5.

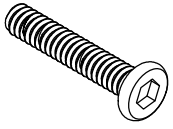

B x8

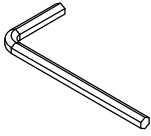

D x1

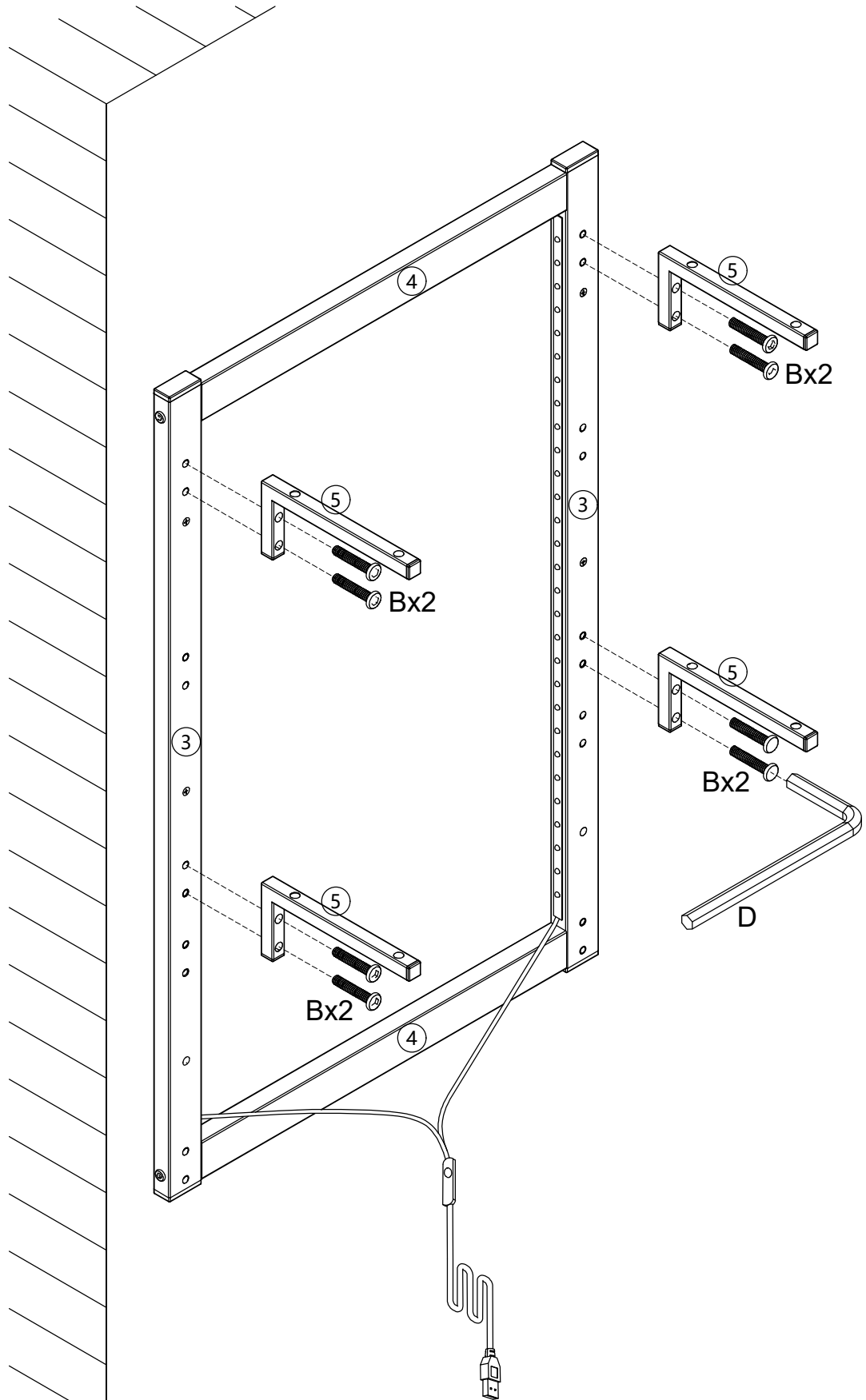

Step 6.

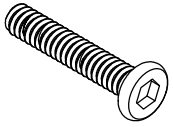

B x4

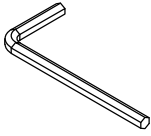

D x1

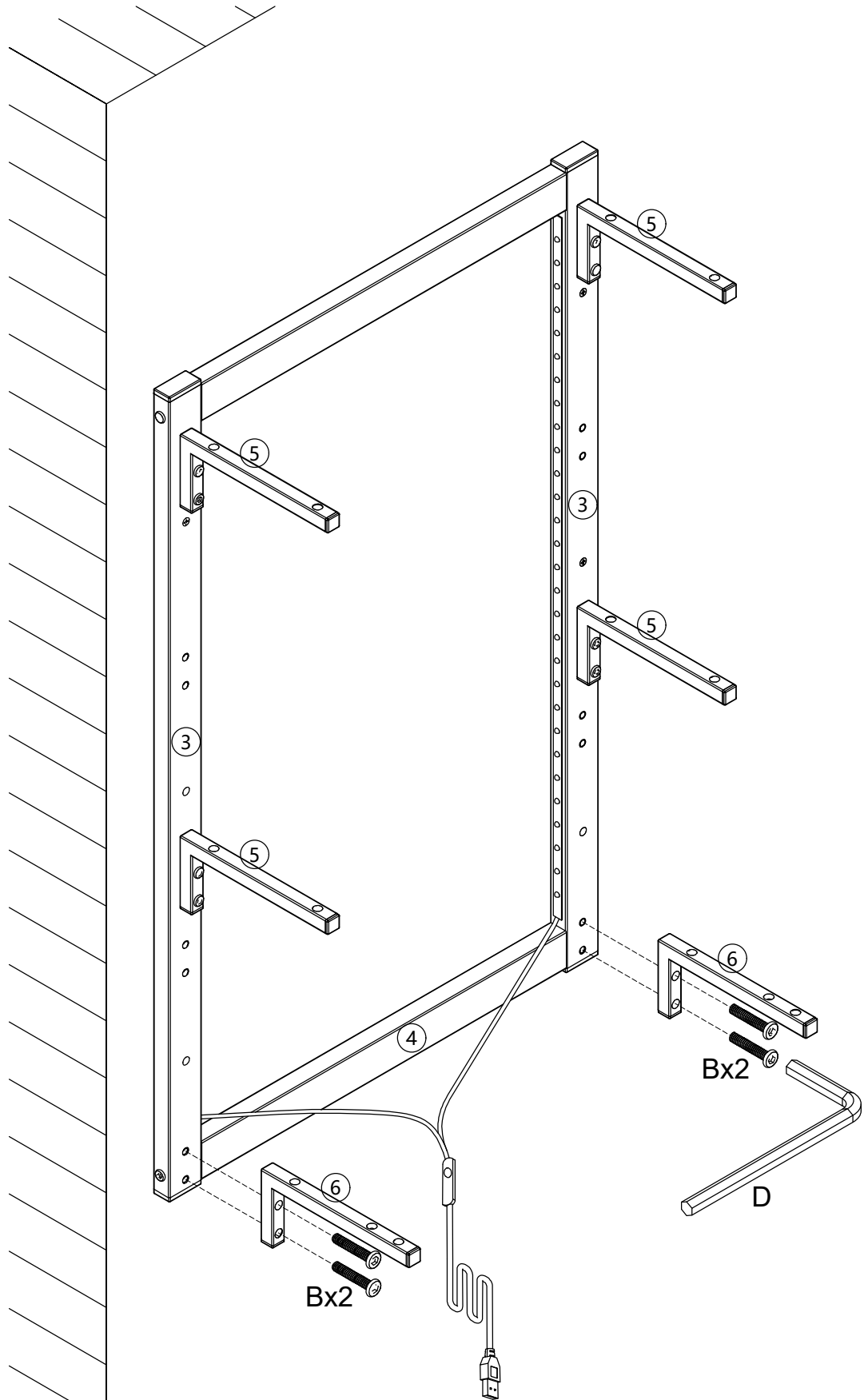

Step 7.

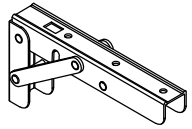

J x2

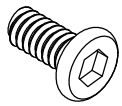

K x4

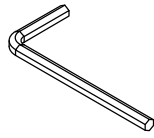

D x1

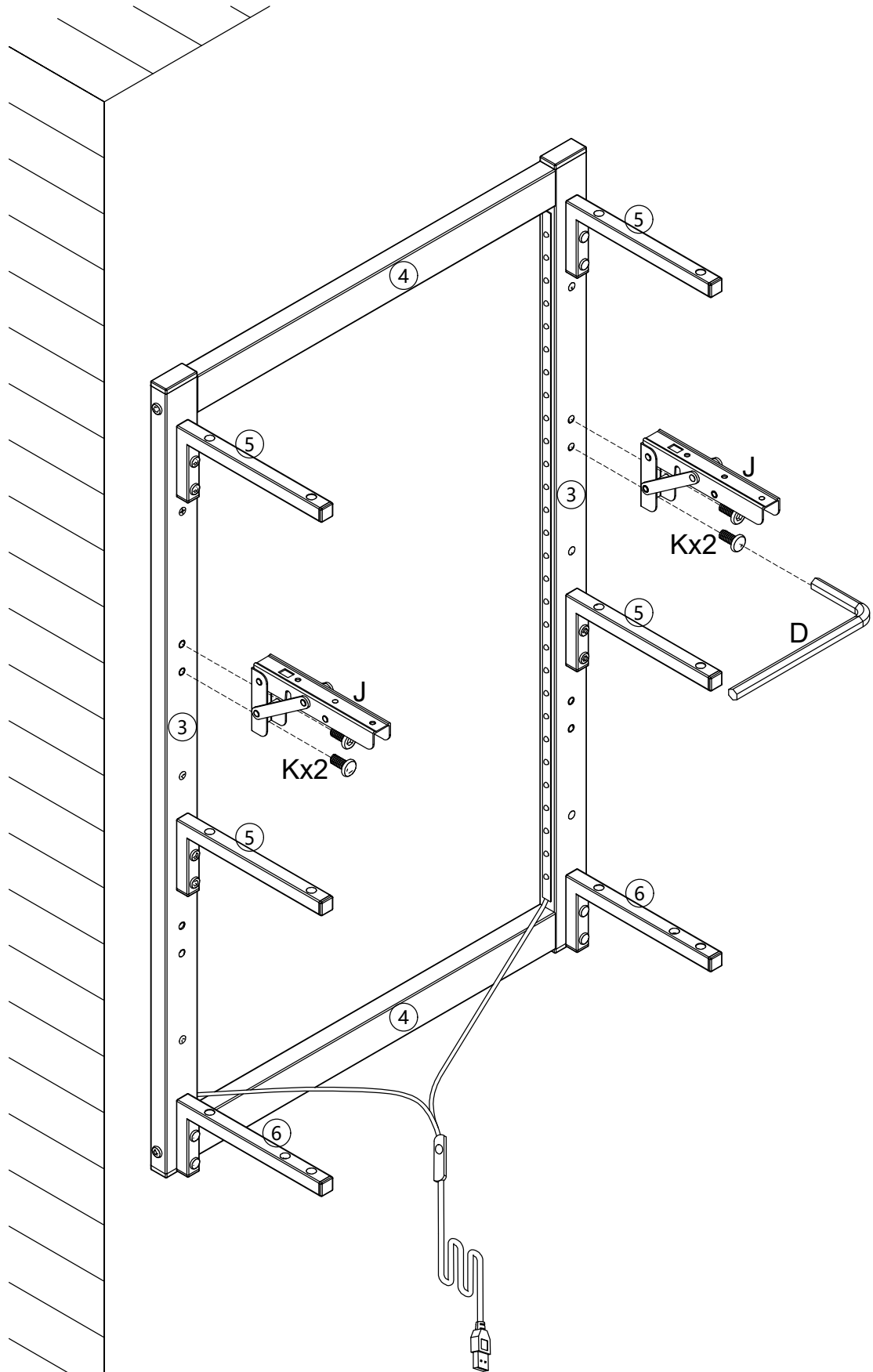

Step 8.

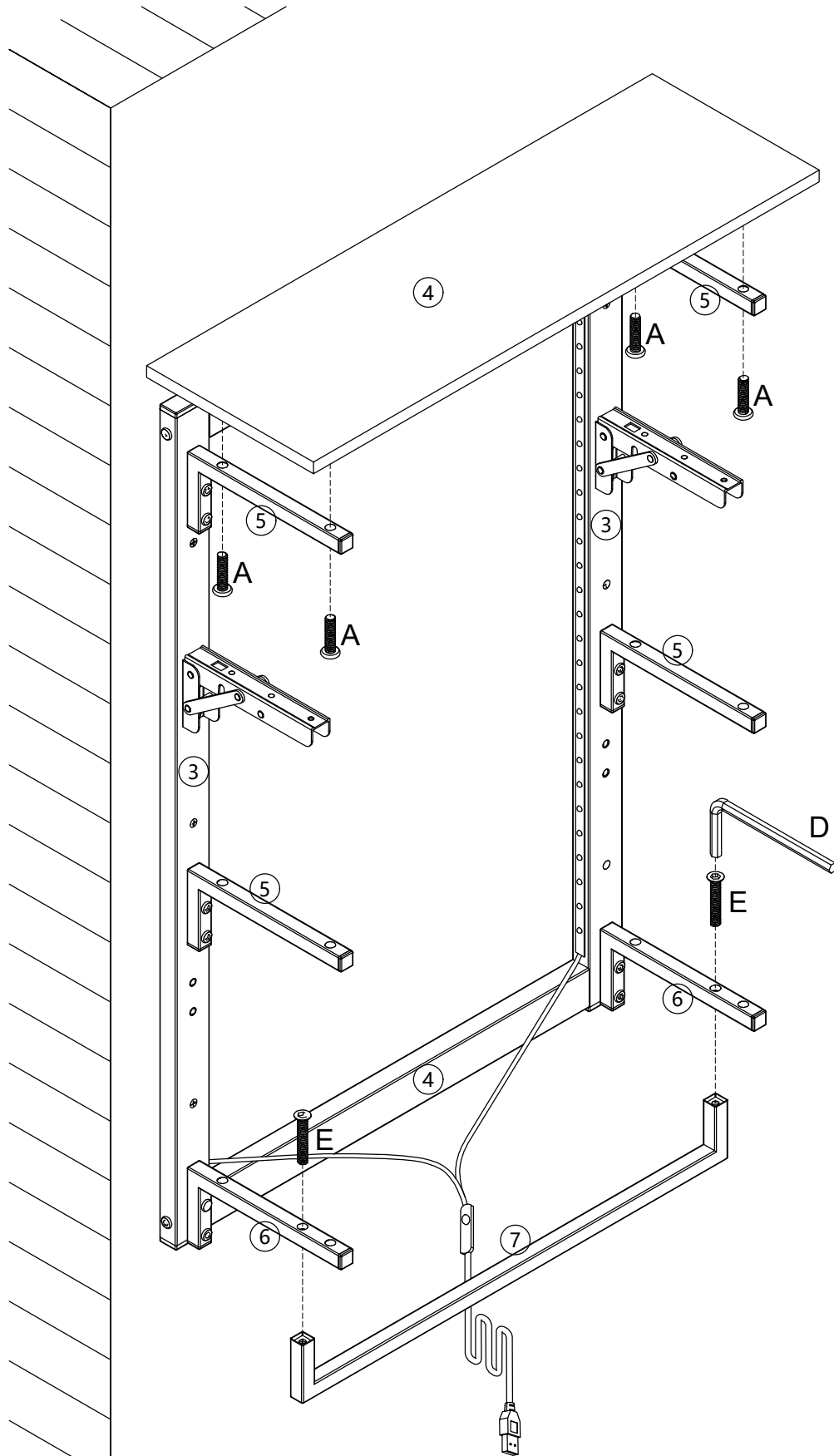
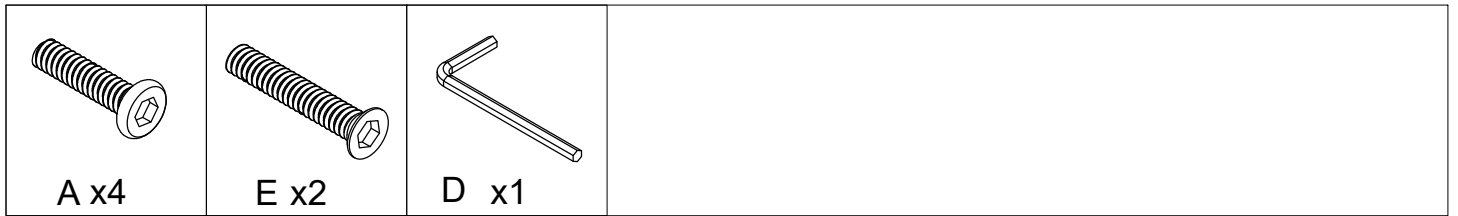

Step 9.

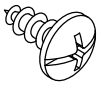

L x4



M x1

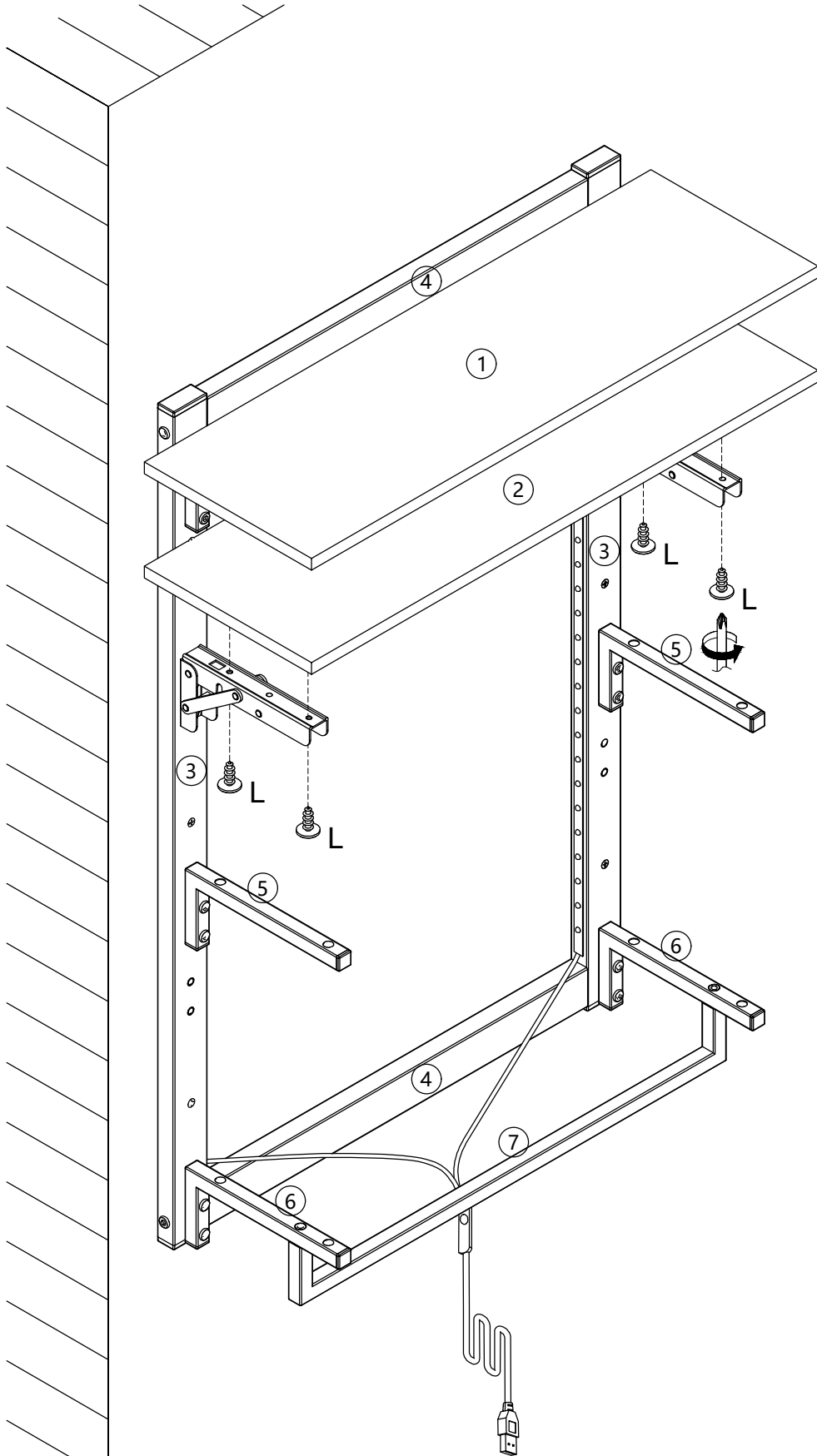

Step 10.

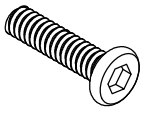

A x8

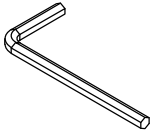

D x1

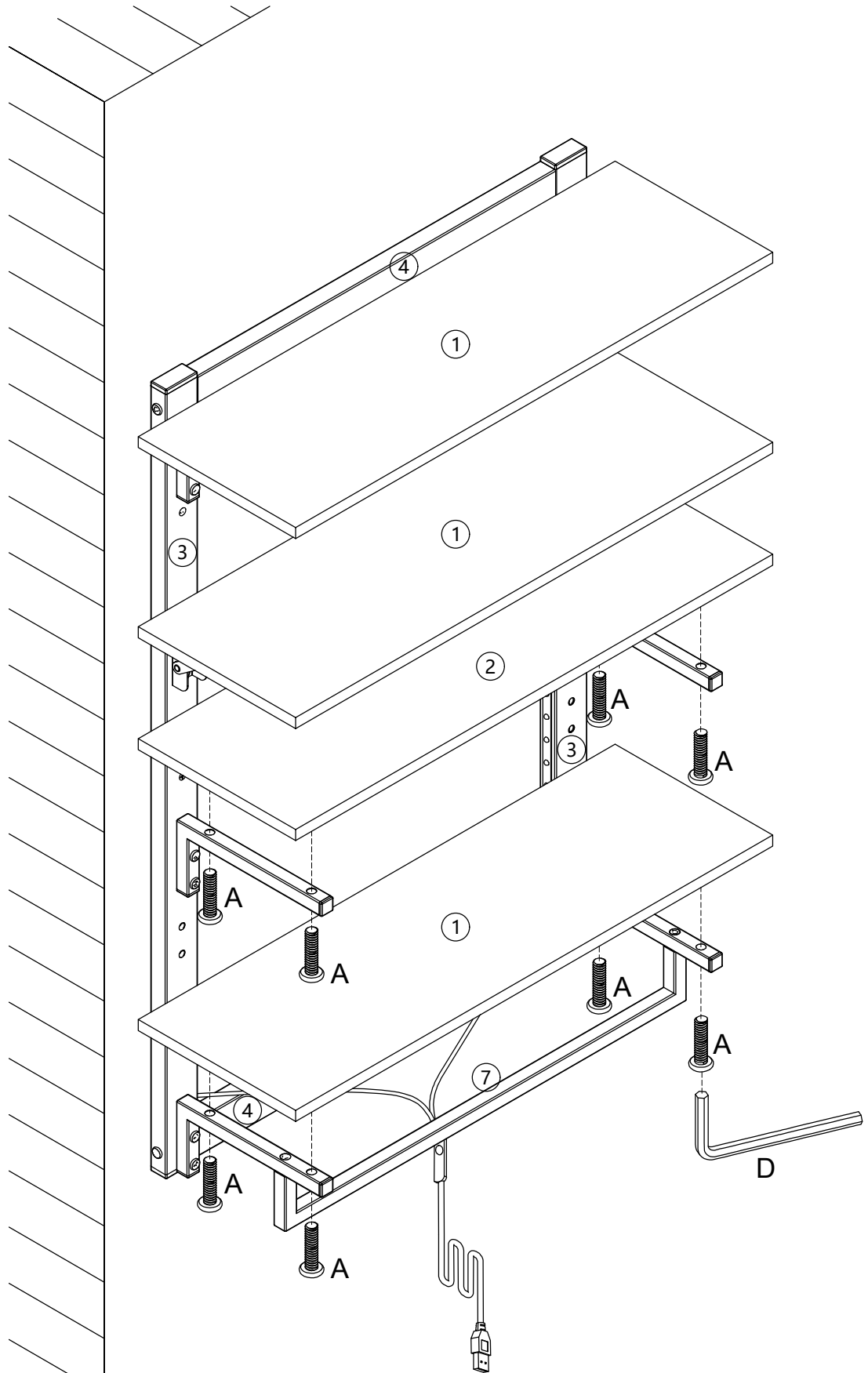

Step 11.



F x8

