

Assembly Instructions

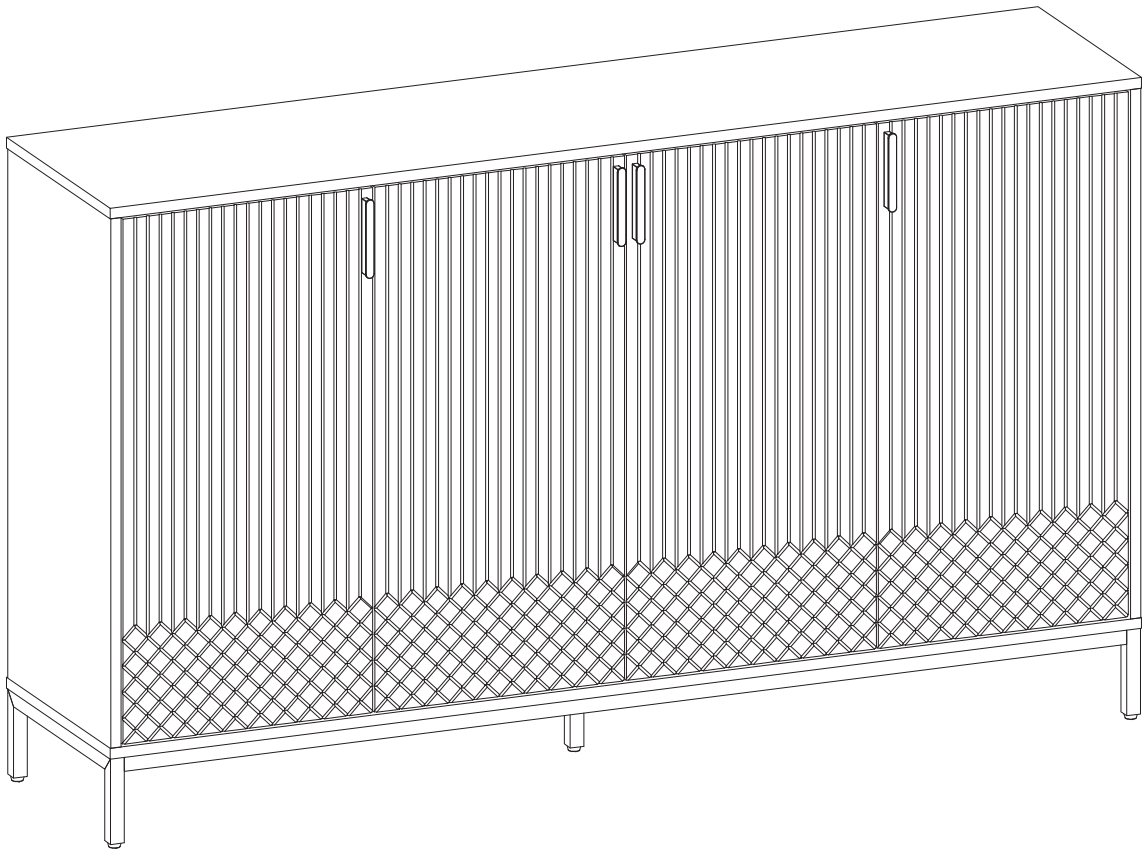

Sideboard

Warm Tips

1. Carefully read these instructions and keep them for future reference.
2. Check the parts list and confirm everything's there before starting assembly.
3. When assembling, put all parts on a soft, smooth surface like a carpet to avoid scratches.
4. Don't fully tighten screws until all parts are confirmed in place to avoid misalignment.

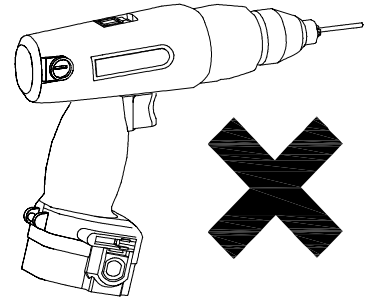
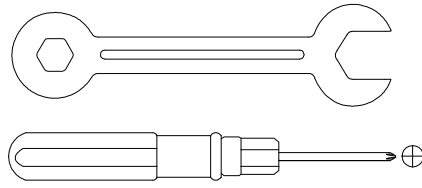
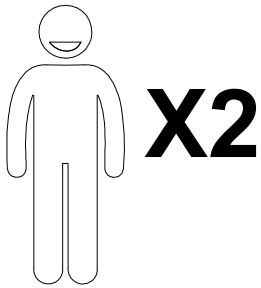

We recommend using hand tools for assembly.

If an electric screwdriver is used, reduce power and torque to avoid damage to the product.

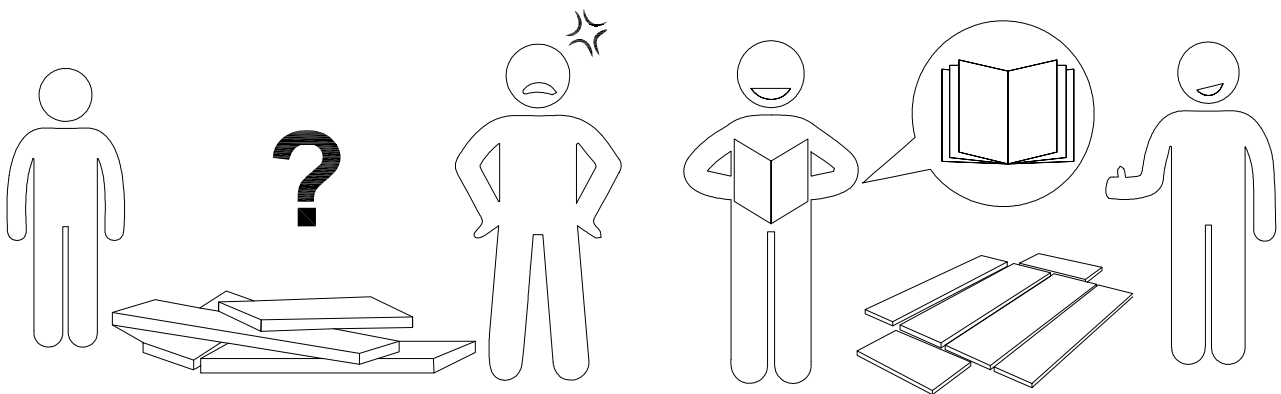

Install the Anti-Tip Straps

Using the anti-tip straps can reduce the risk of tipping over, but can not eliminate it.

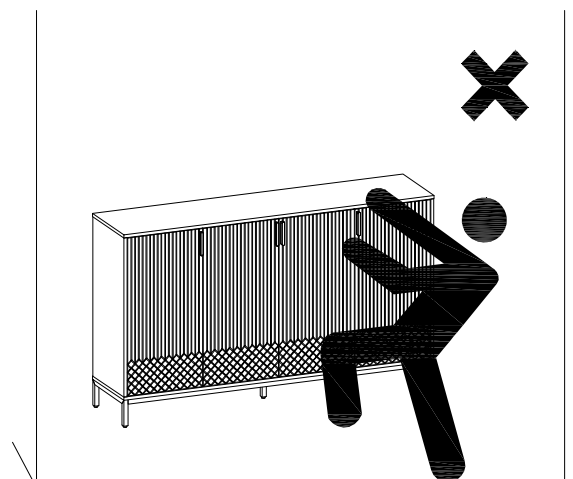
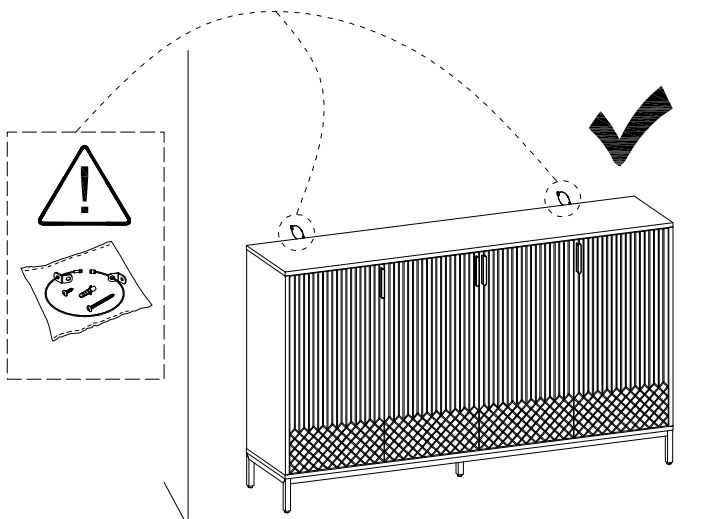

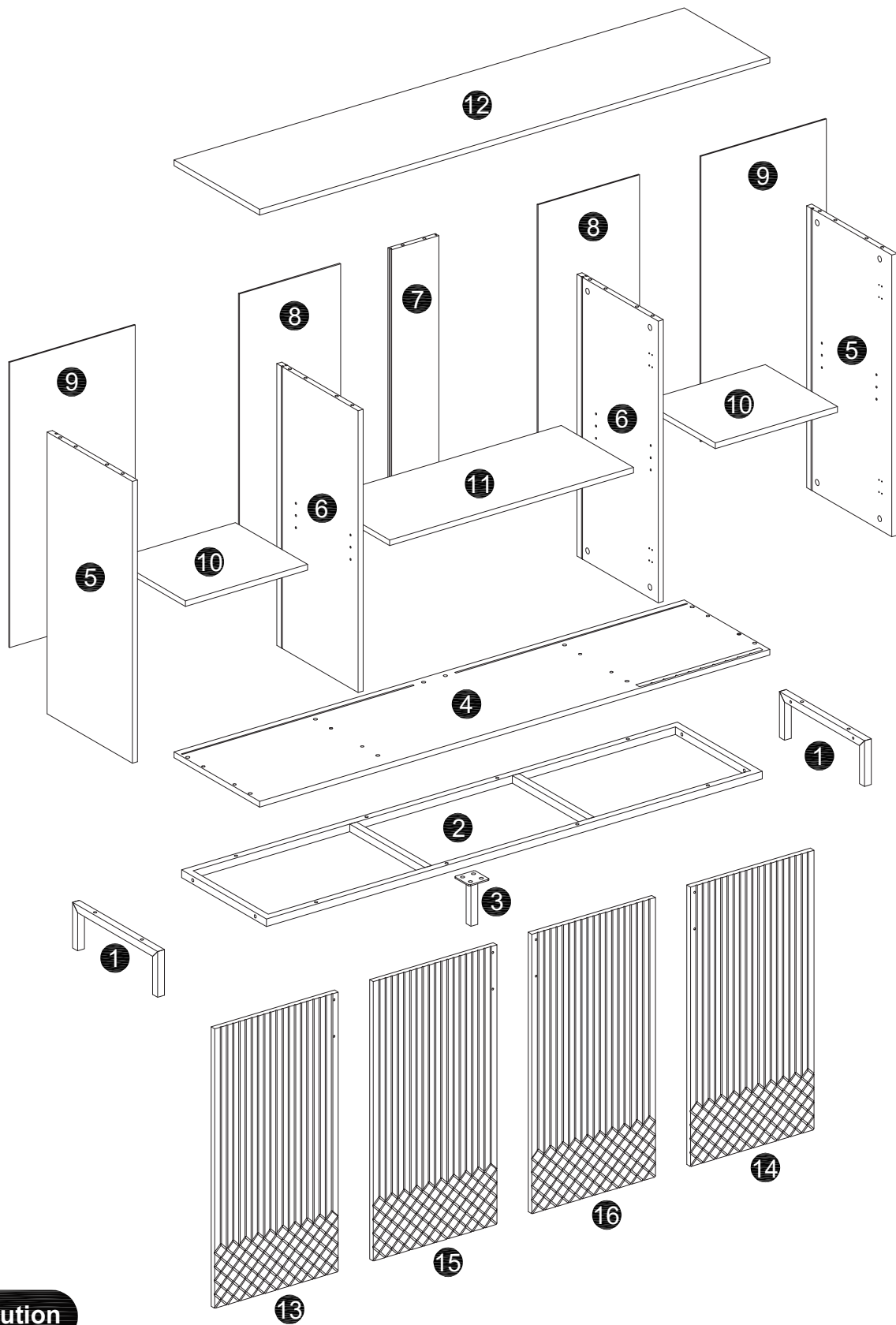



⚠ Caution

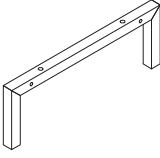
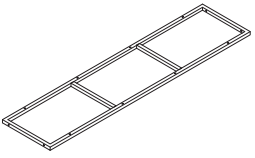
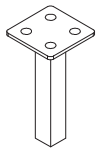
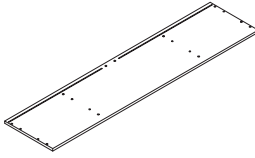
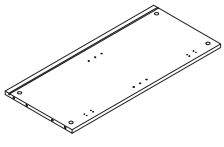
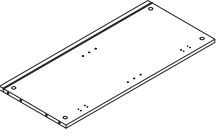

Make sure all parts are included. Most board parts are labeled or stamped on the raw edge. Contact us for a free replacement if you encounter any damaged or missing parts.

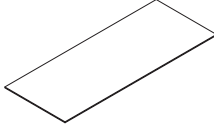
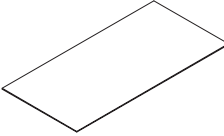
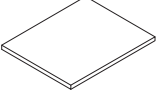
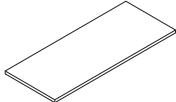
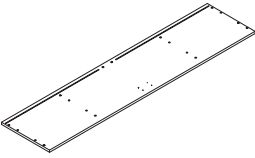
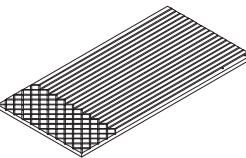
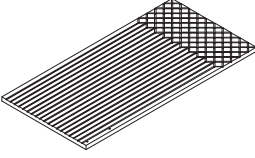
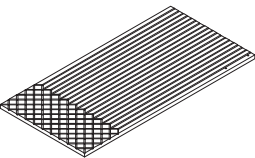
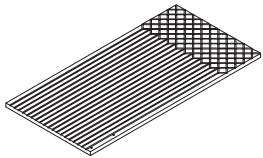

Parts List

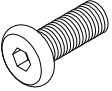
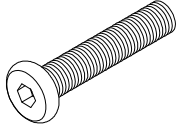
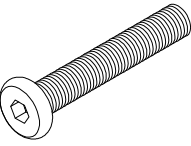
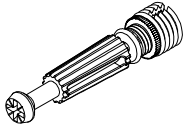
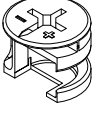
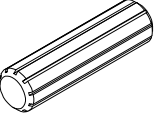
<p>1</p>  <p>2 pcs</p>	<p>2</p>  <p>1 pc</p>	<p>3</p>  <p>1 pc</p>	<p>4</p>  <p>1 pc</p>	<p>5</p>  <p>2 pcs</p>
<p>6</p>  <p>2 pcs</p>	<p>7</p>  <p>1 pc</p>	<p>8</p>  <p>2 pcs</p>	<p>9</p>  <p>2 pcs</p>	<p>10</p>  <p>2 pcs</p>
<p>11</p>  <p>1 pc</p>	<p>12</p>  <p>1 pc</p>	<p>13</p>  <p>1 pc</p>	<p>14</p>  <p>1 pc</p>	<p>15</p>  <p>1 pc</p>
<p>16</p>  <p>1 pc</p>				

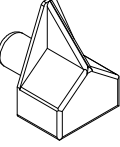
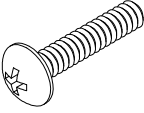
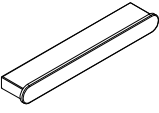
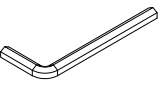
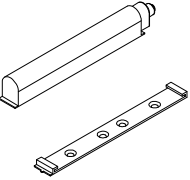
Hardware List

A	B	C	D	E	F
					
M6x15mm	M6x30mm	M6x35mm	M6x40mm	Ø15x12mm	Ø8x30mm
5 pcs	13 pcs	5 pcs	21 pcs	21 pcs	17 pcs

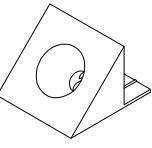
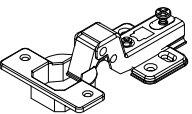
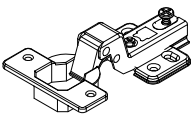
G	H	I	J	K	L
					
	Ø4x20mm		M4		Ø3.5x12mm
13 pcs	9 pcs	4 pcs	1 pc	2 pcs	3 pcs

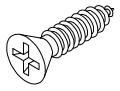
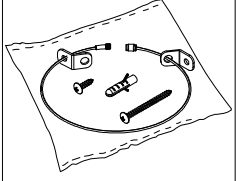
M	N	O	P	Q	R
					
			Ø3.5x14mm	Ø3x18mm	
25 pcs	4 pcs	4 pcs	53 pcs	25 pcs	2 pcs

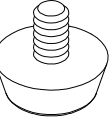
S					
					
6 pcs					

Installation of Cams and Pins

Screw the pin into the hole. To set the cams correctly, ensure that the arrow on the cam is opening to the hole of the pin it is locking. Lock the cam by turning the cam head with a screwdriver until it is tightened. Please do not use an electric screwdriver to assemble the unit.

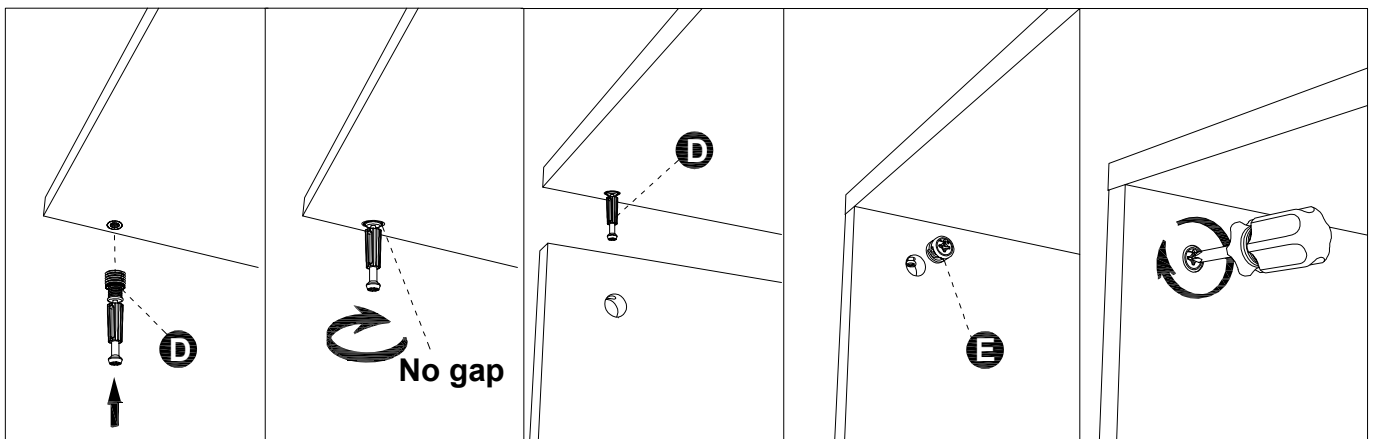

Read each step carefully before starting. It is very important that each step of instruction is performed in the correct order. If these steps are not followed in sequence, assembly difficulties will occur.

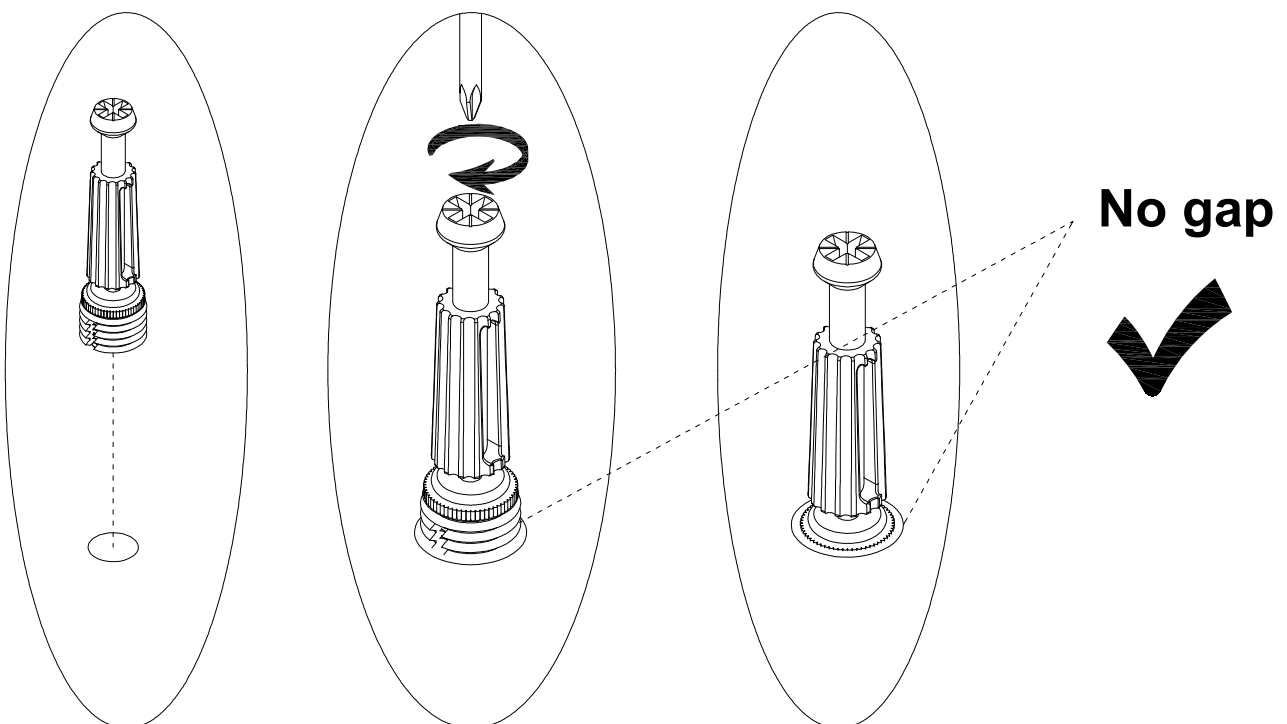

1

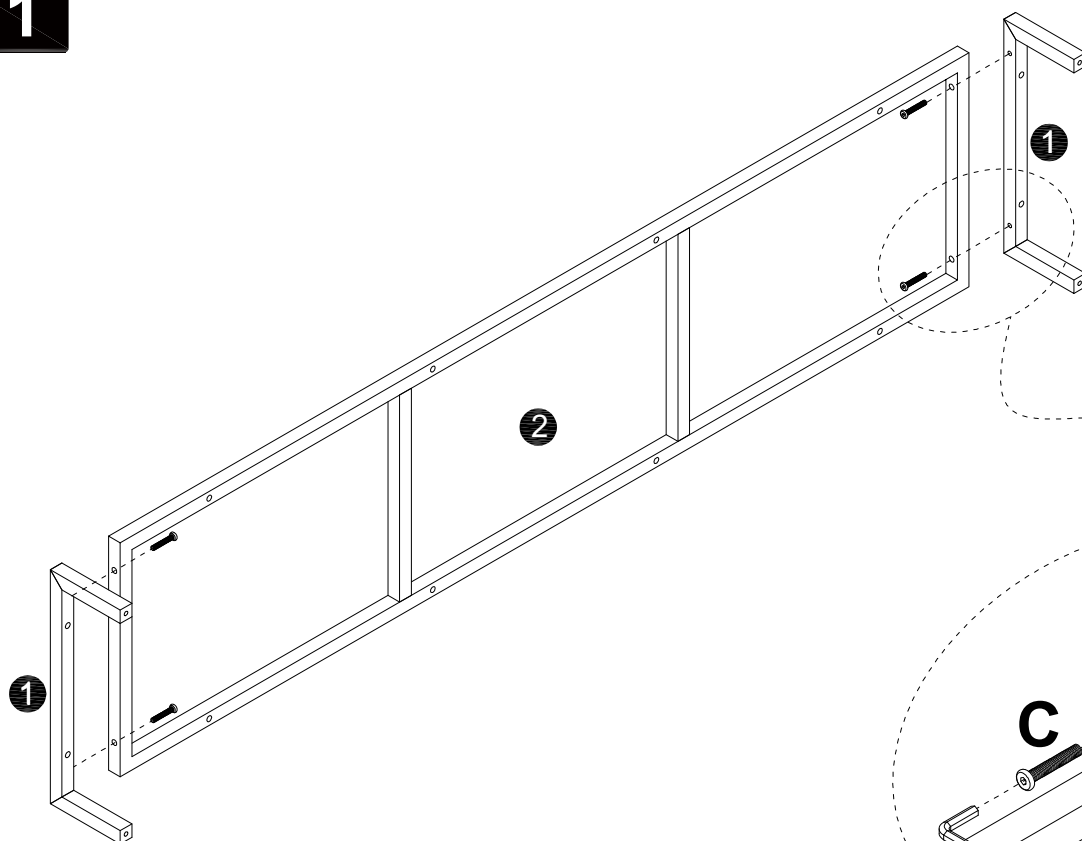

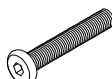

C

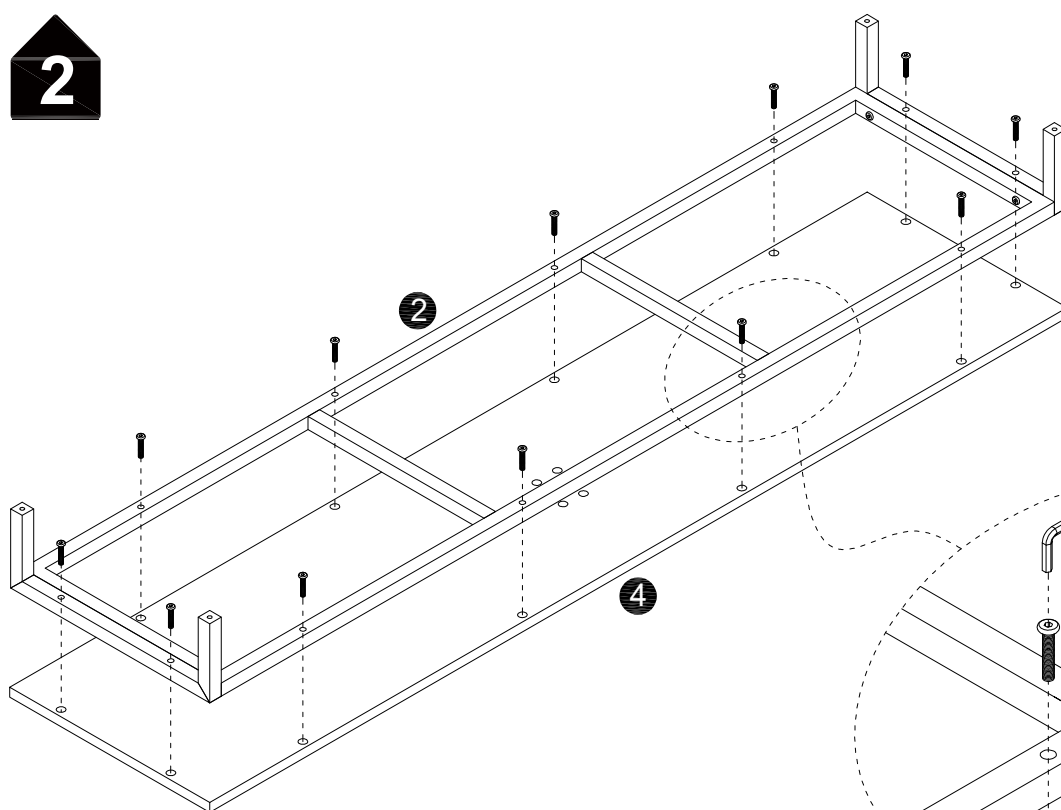
M6x35mm
4 pcs

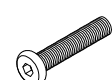
2



B

M6x30mm
12 pcs

3

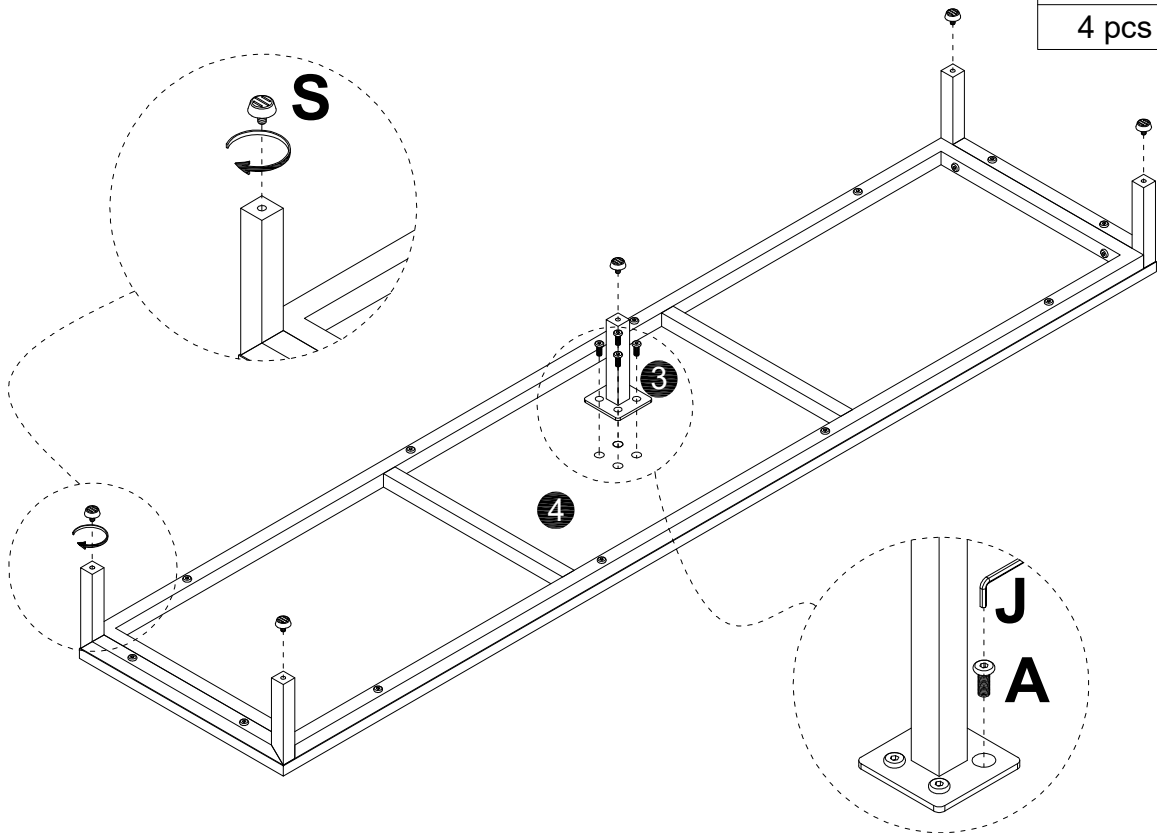
A	S
	
M6x15mm	
4 pcs	5 pcs



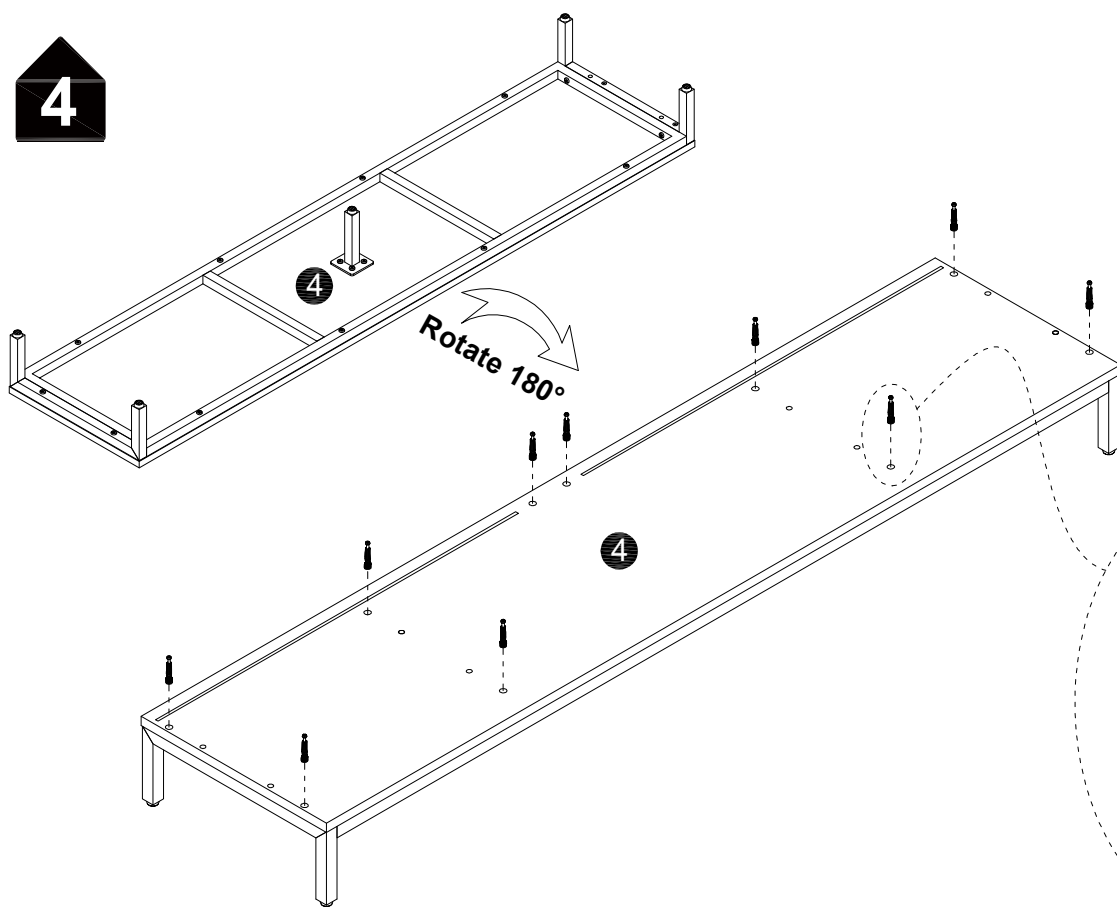

4

D

M6x40mm
10 pcs

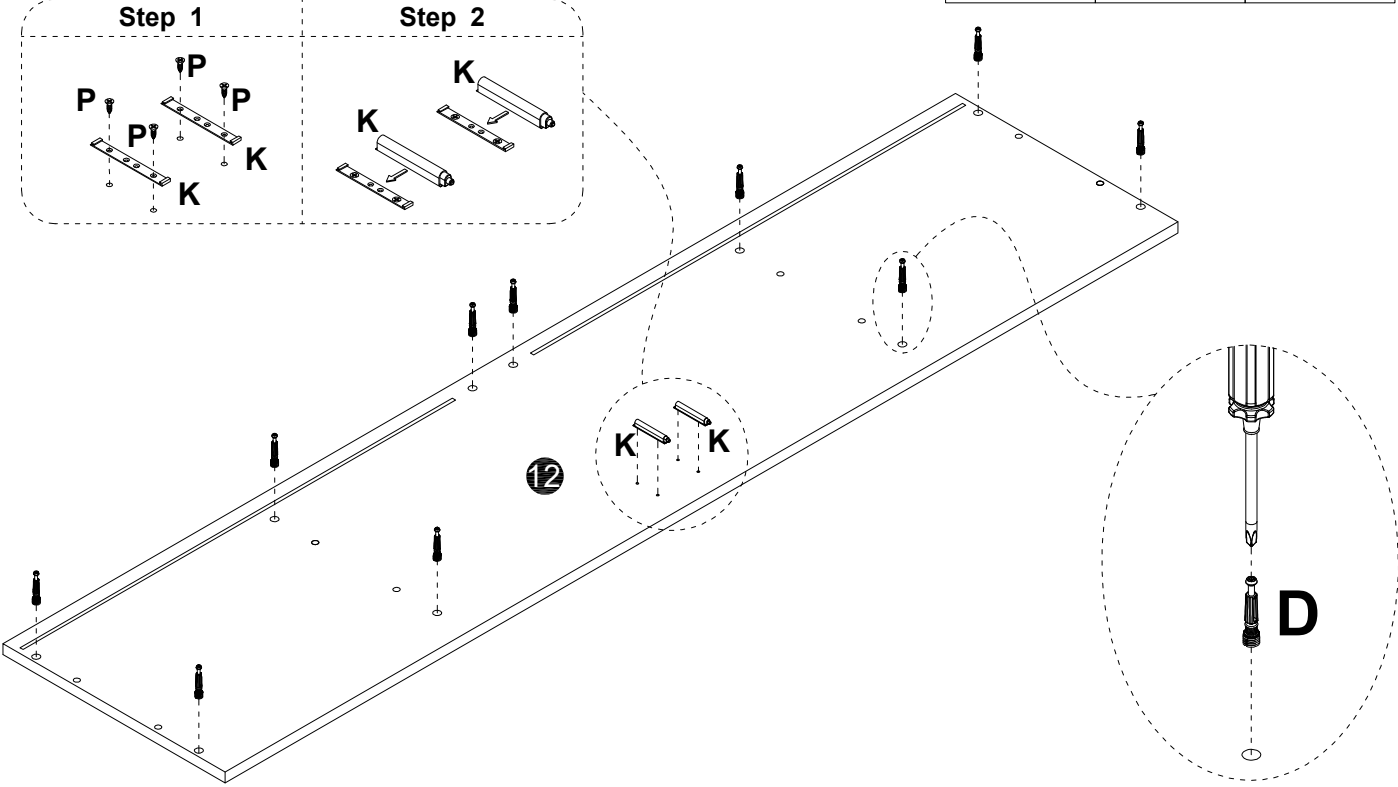

5

D	K	P
		
M6x40mm		Ø3.5x14mm
10 pcs	2 pcs	4 pcs

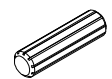

6

E	F
	
Ø15x12mm	Ø8x30mm
10 pcs	8 pcs

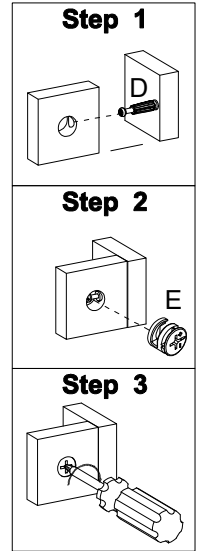
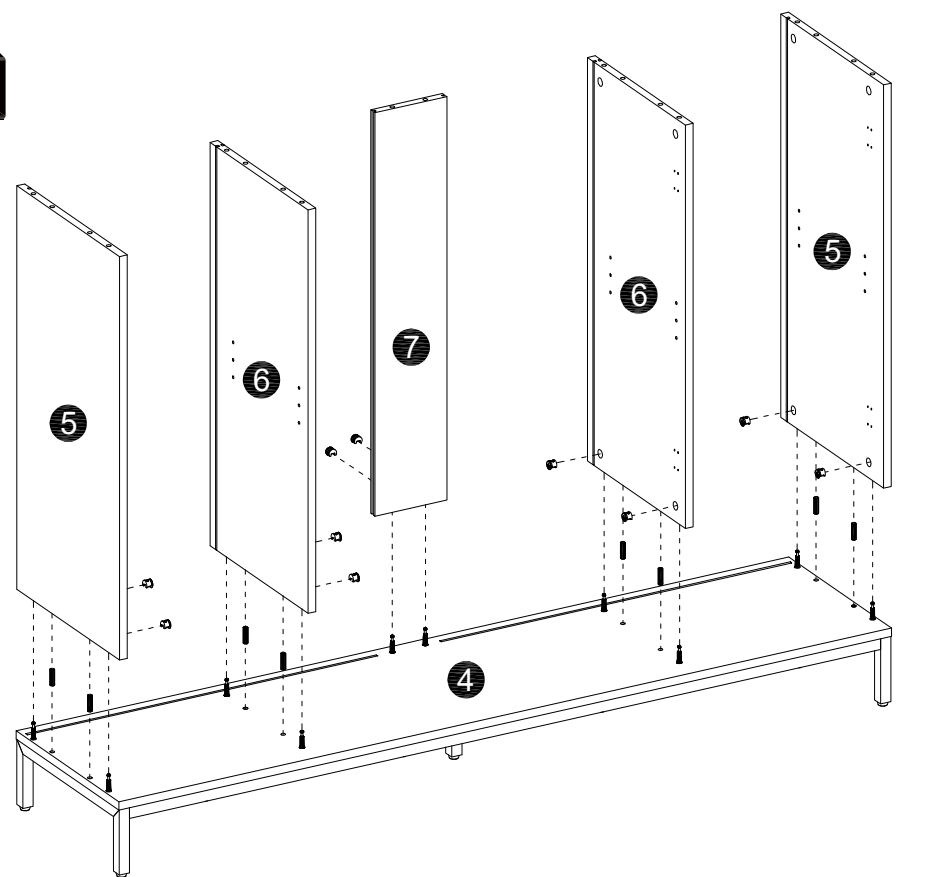

7

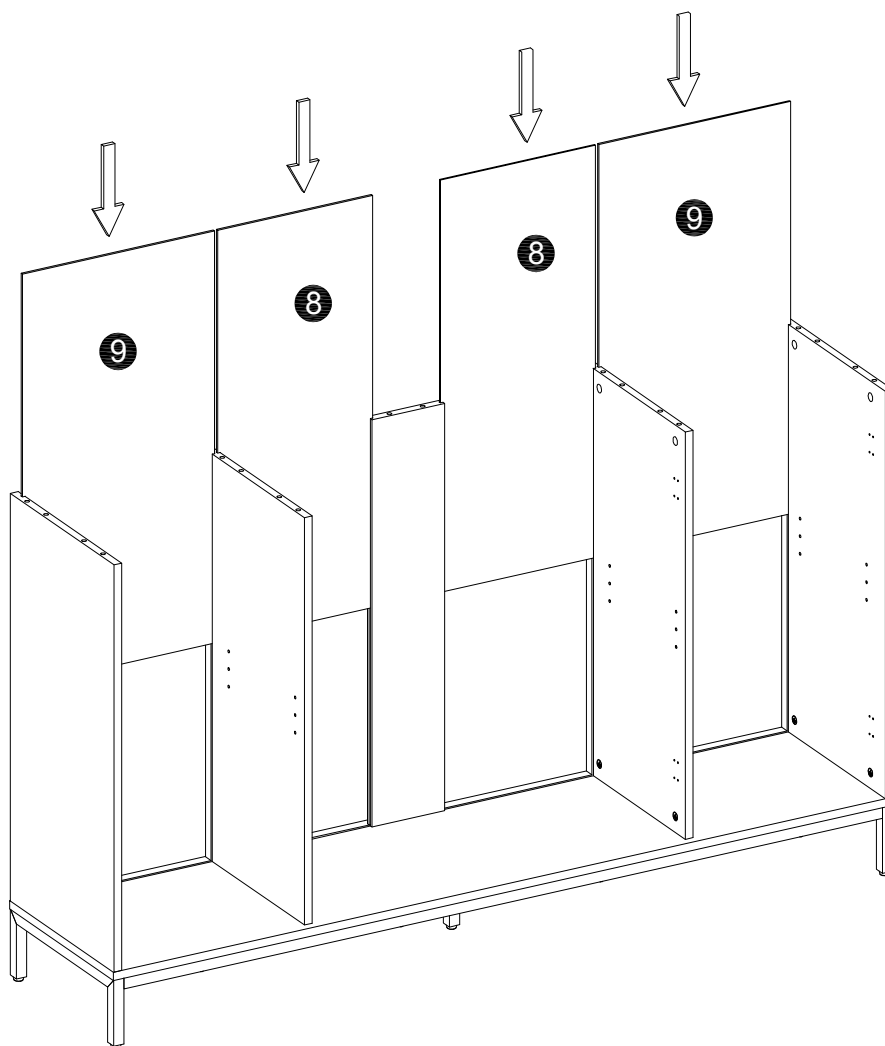

8

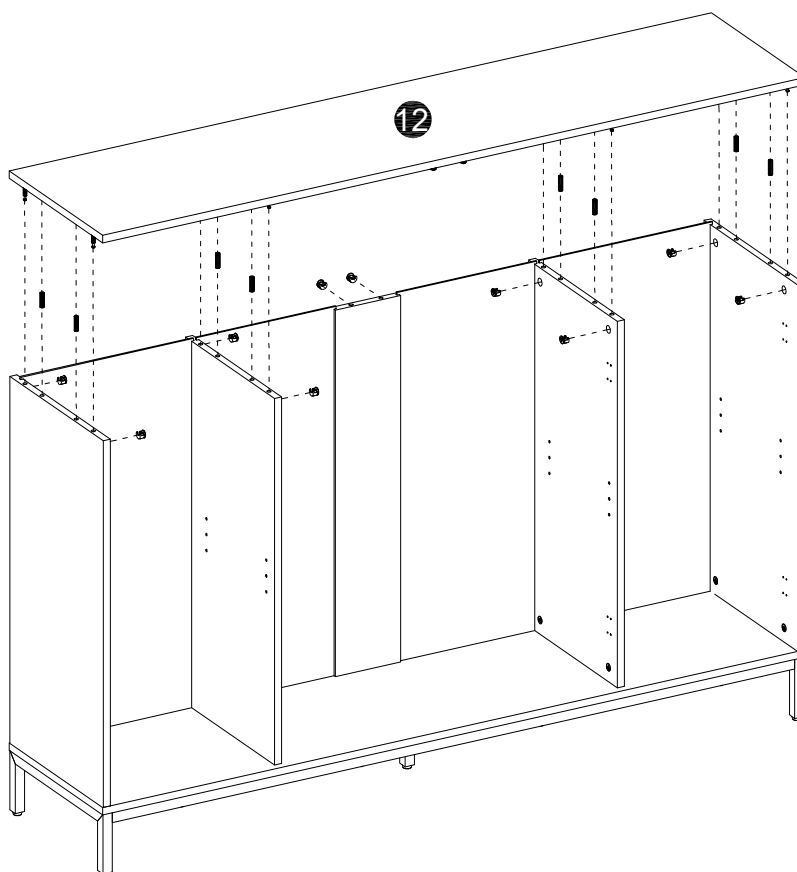

E	F
Ø15x12mm	Ø8x30mm
10 pcs	8 pcs

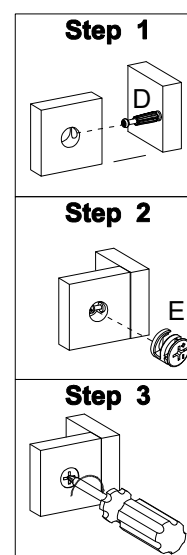

9

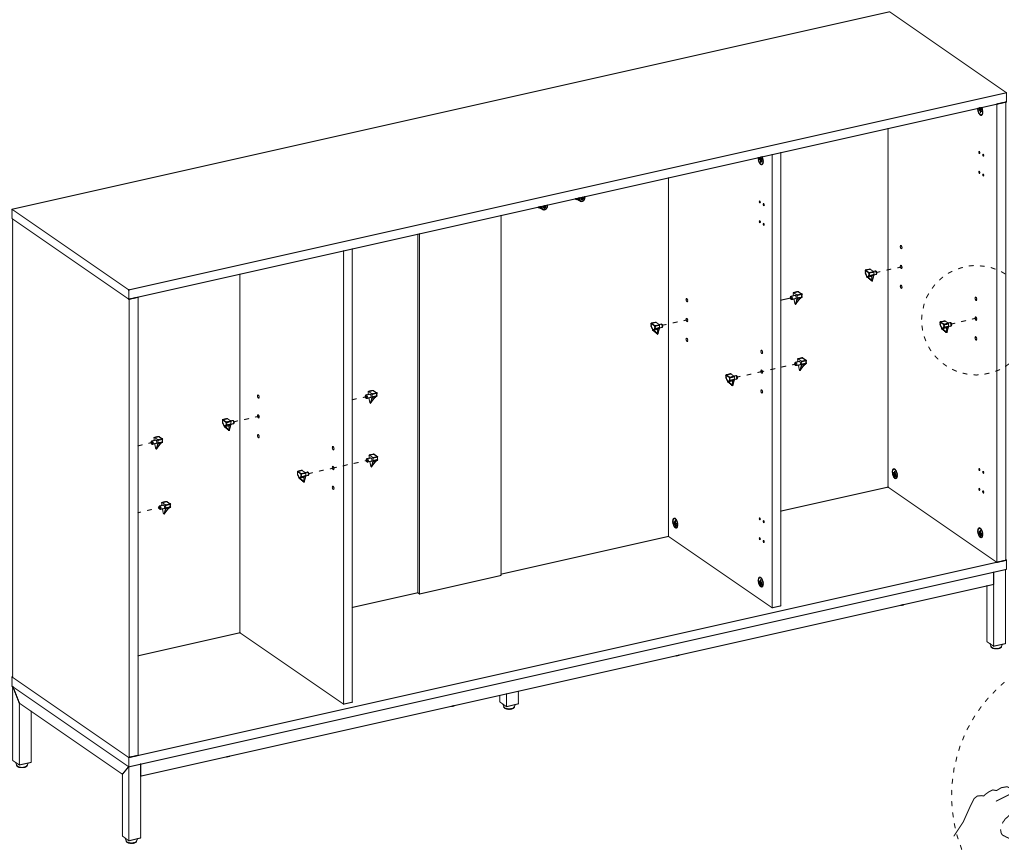

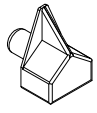
G

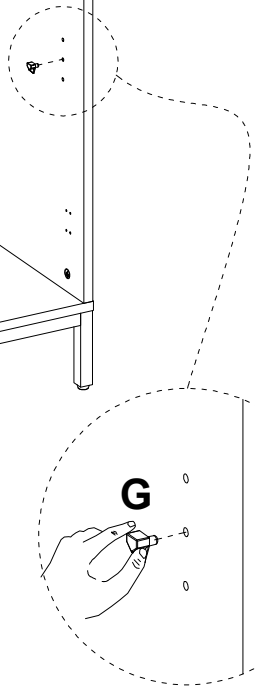
12 pcs



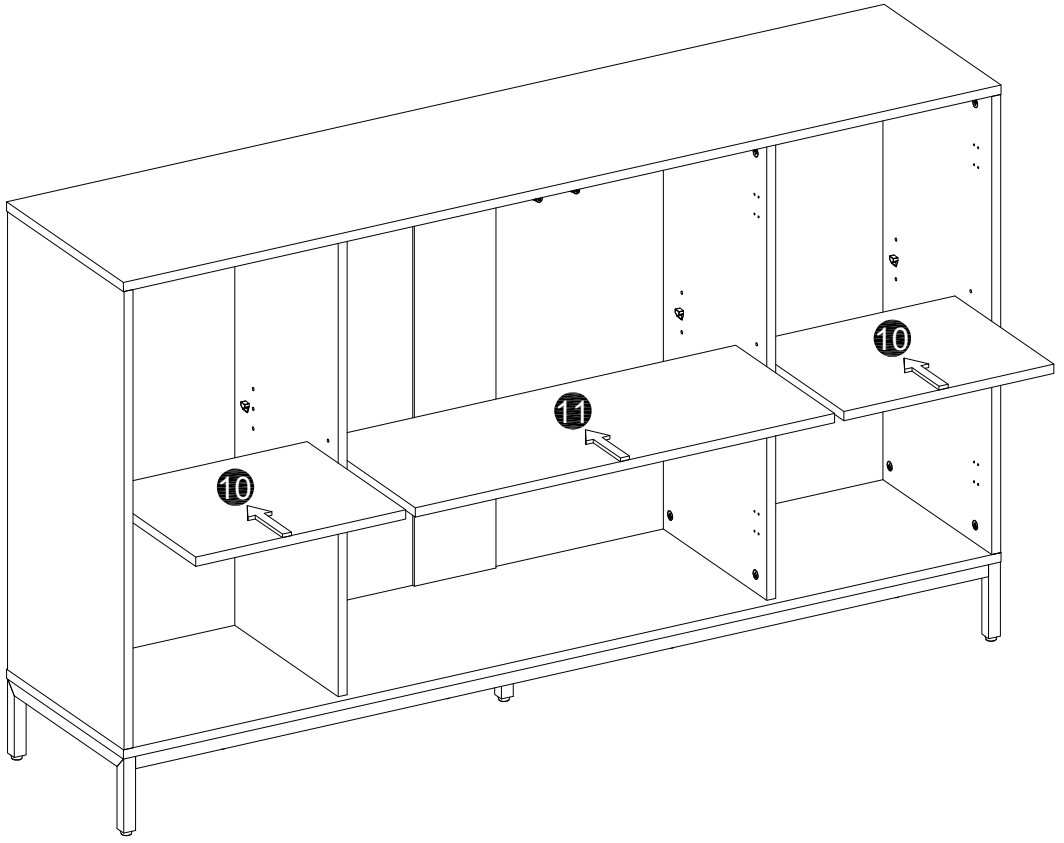

10

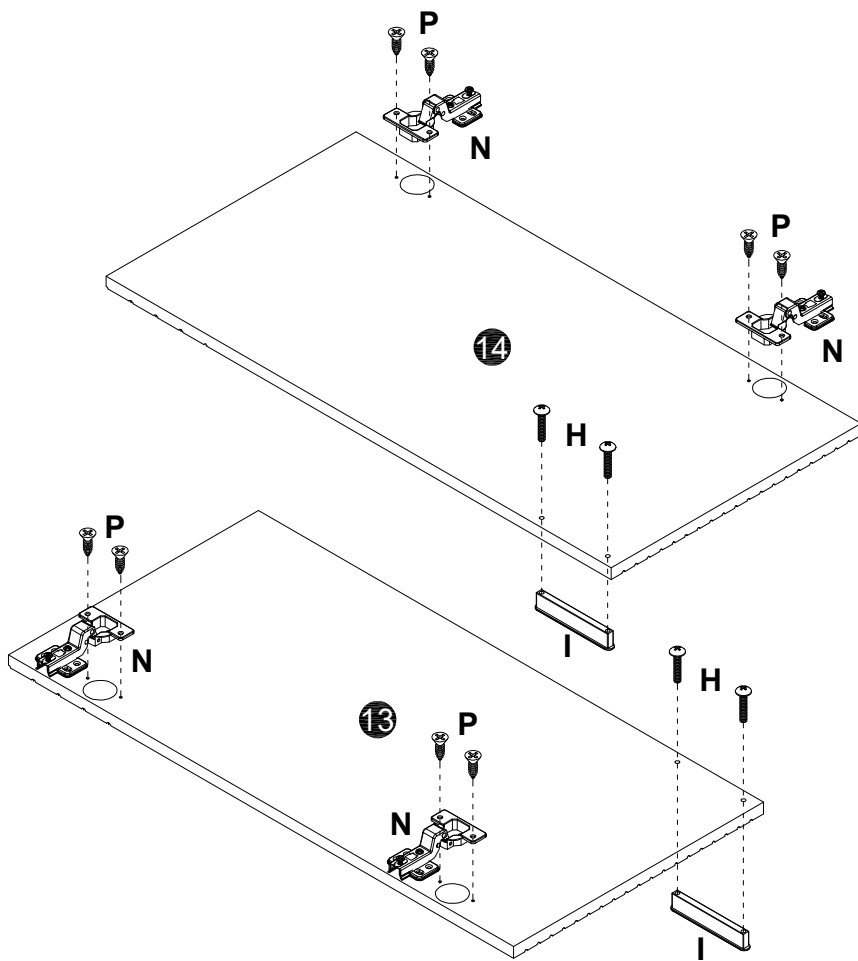



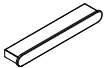



11

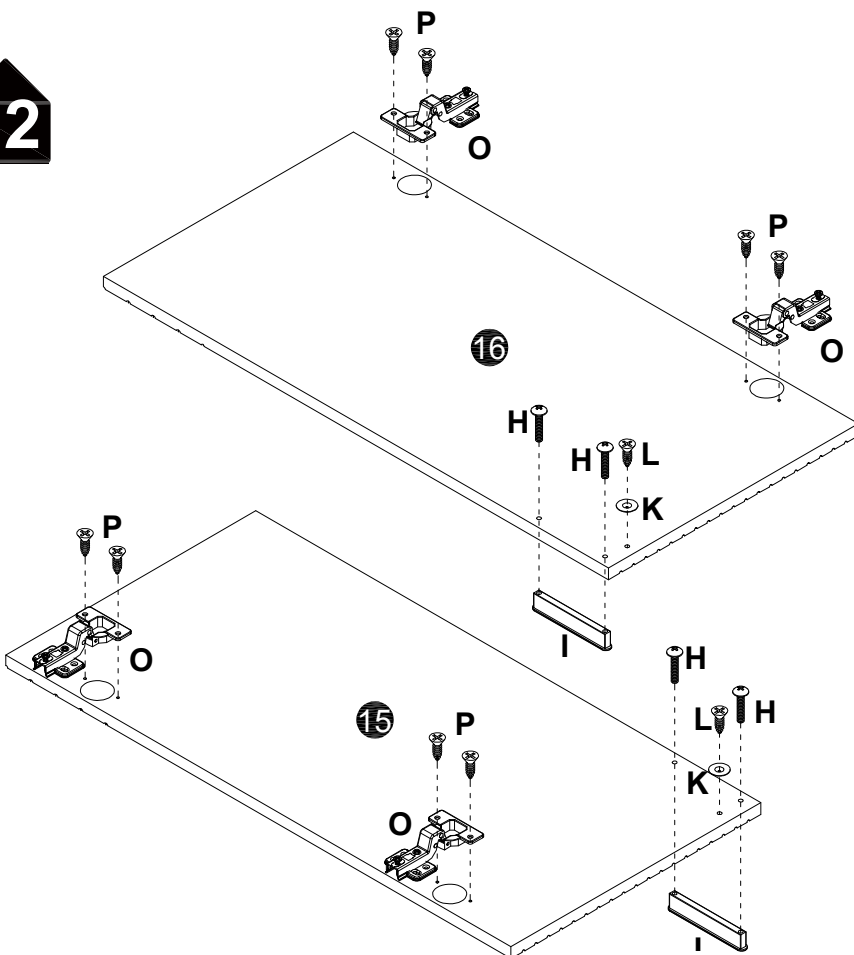

H	I
 Ø4x20mm	
4 pcs	2 pcs
N	P
	 Ø3.5x14mm
4 pcs	8 pcs

12

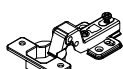

H	I	K
 Ø4x20mm		
4 pcs	2 pcs	2 pcs
O	P	L
	 Ø3.5x14mm	 Ø3.5x12mm
4 pcs	8 pcs	2 pcs

13

P

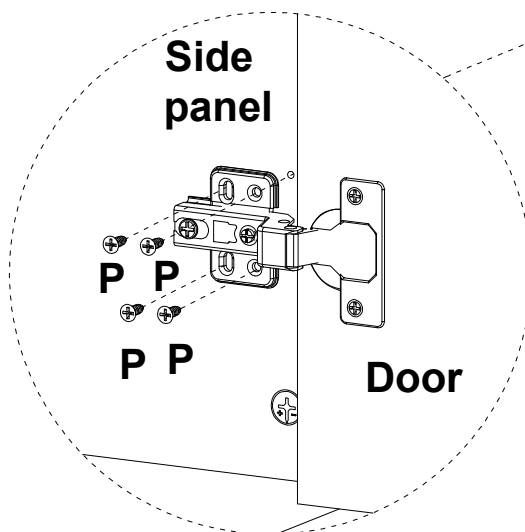
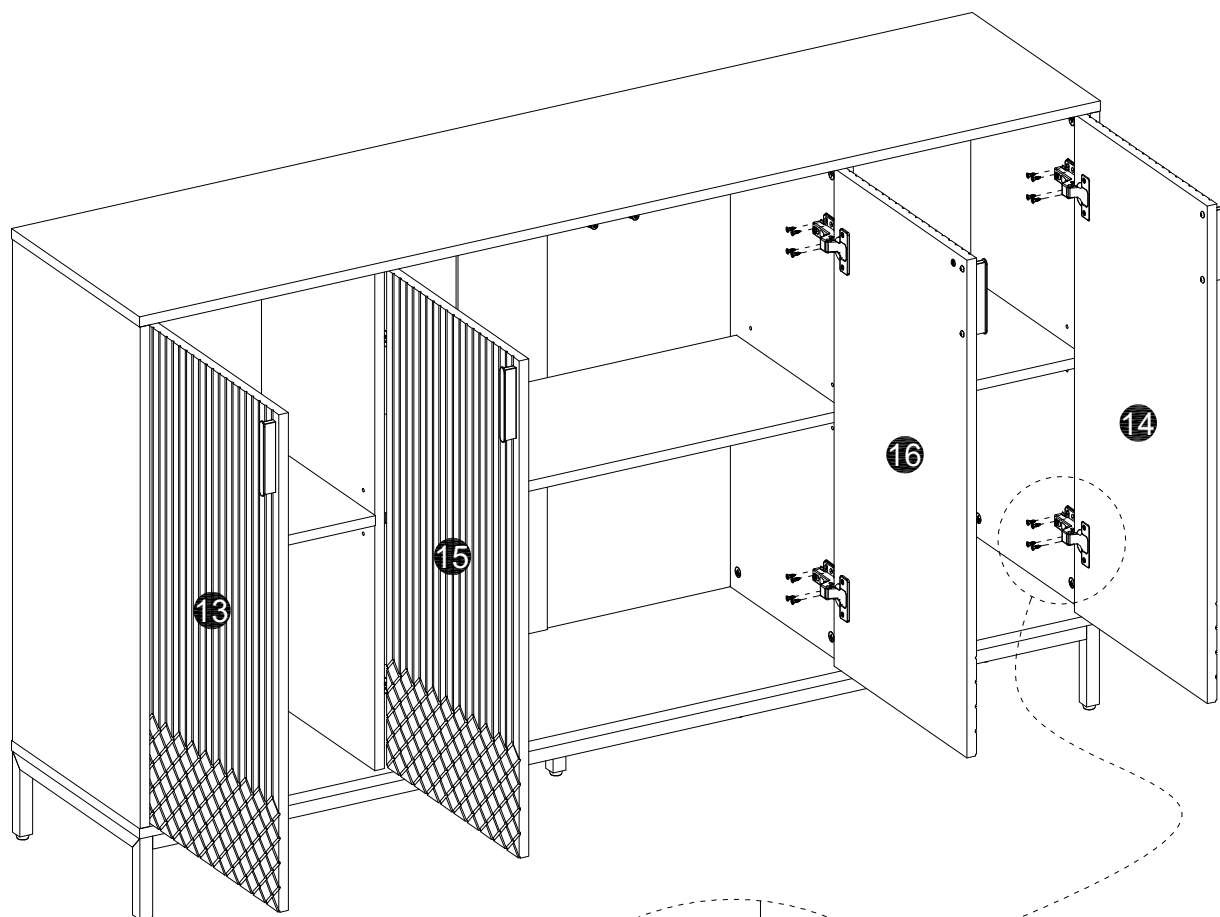
Ø3.5x14mm
32 pcs



To prevent the door hinge from falling off, please install 4 screws

TO ADJUST YOUR DOORS TO MAKE THE GAPS MORE EVEN (OPTIONAL).

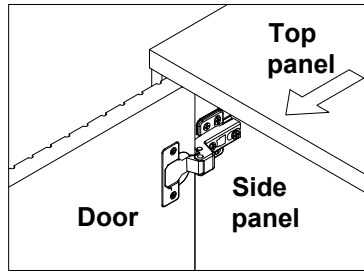
Step 1
Open the door.



Step 2
Adjust the door panel to be flush with side panel and top panel edge.

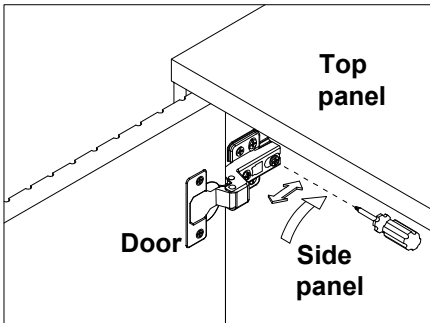

Loosen the screw indicated a little, adjust the hinge to right position (see step 2a & 2b), then tighten the screw.

Step 2a MOVE DOOR OUT

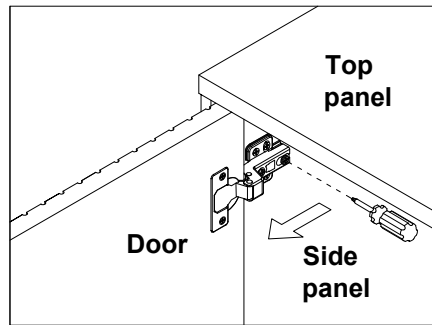
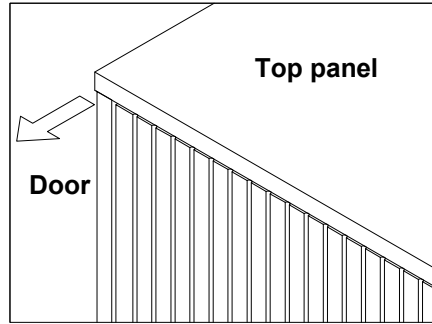

Pull the hinge forward a little.

Step 2b MOVE DOOR IN

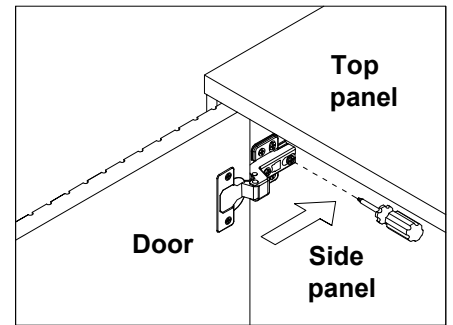
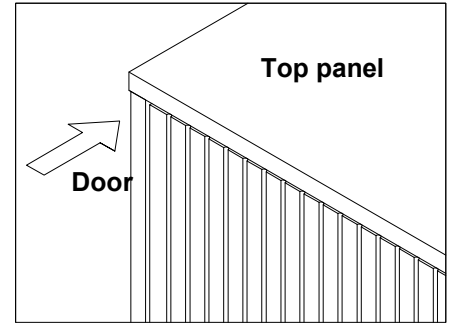

Push the hinge back a little.

Step 3
Adjust the gap between door panel and side panel.



Loosen or tighten the screw indicated a little to adjust the gap between the door panels, adjust the hinge to right position (see step 3a & 3b).

Step 3a MOVE DOOR LEFT

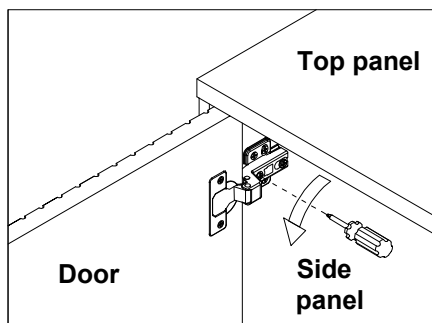
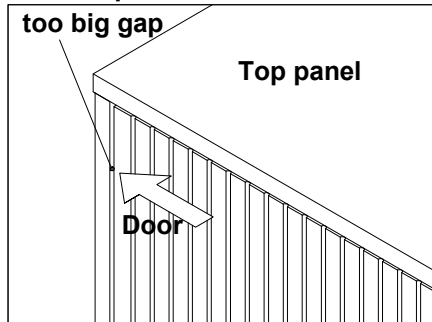

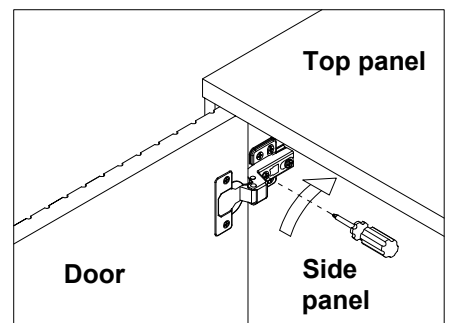
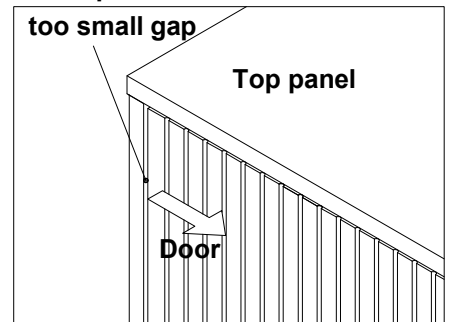

Turn the screw clockwise a little as shown to make the gap small.

Step 3b MOVE DOOR RIGHT



Turn the screw counterclockwise a little as shown to make the gap big.

14

M	Q
	 Ø3.5x18mm
24 pcs	24 pcs

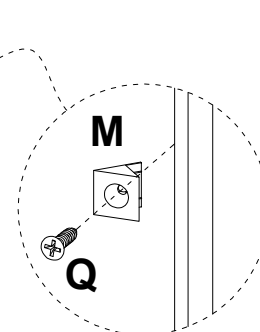
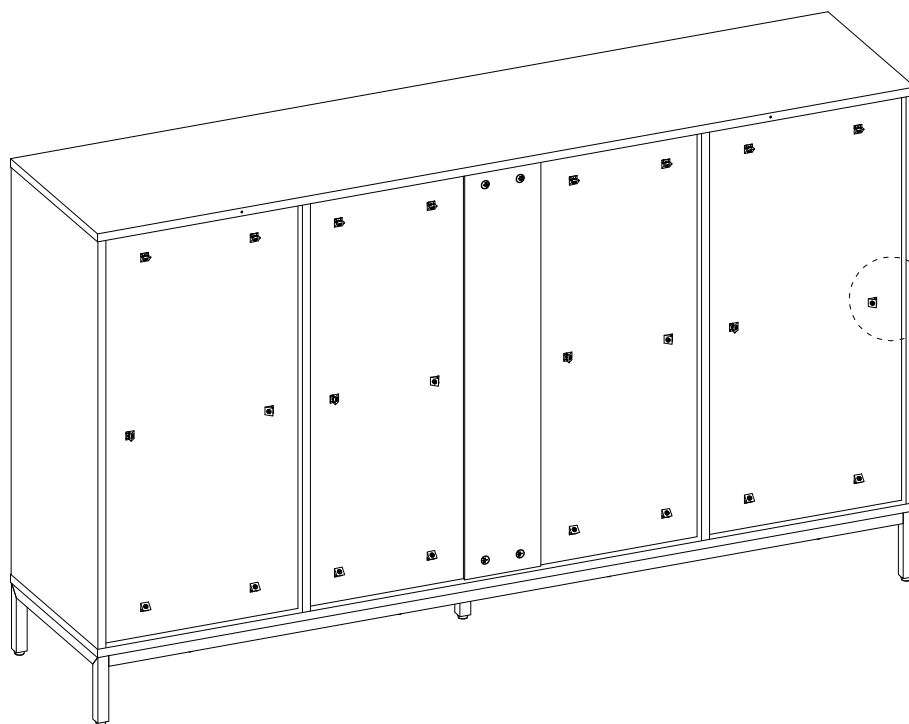

15

R

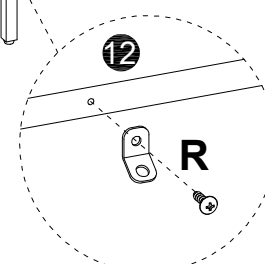
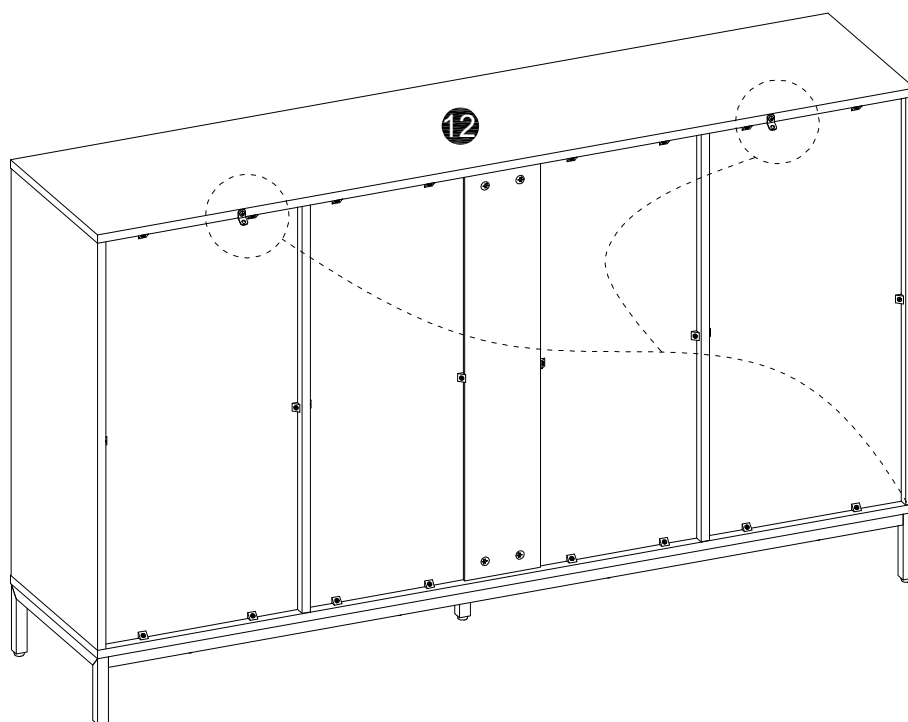
2 pcs

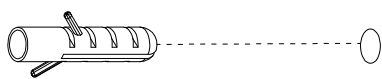

Wall

Step1



Step2

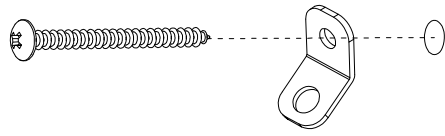

Step3

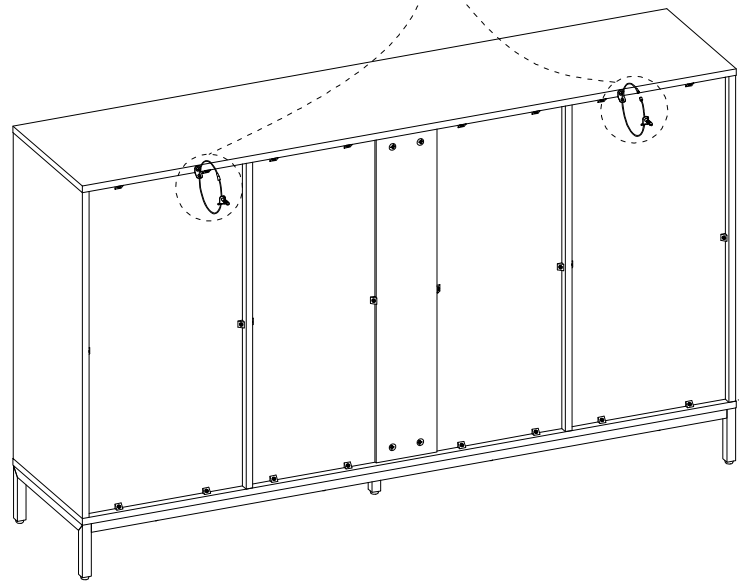
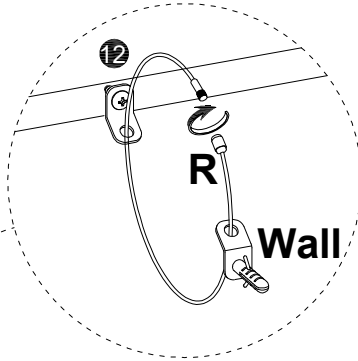

Thank you for your support!

