











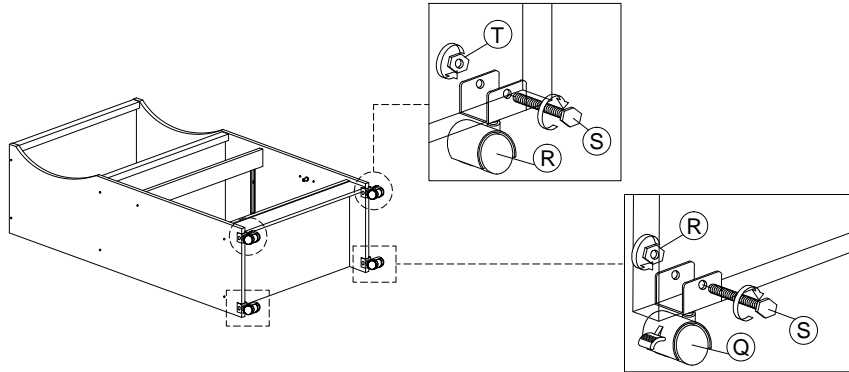

STEP 10

Q		CASTER WITH STOPPER	2
R		CASTER WITHOUT STOPPER	2
S		CASTER BOLT	4
T		CASTER NUT	4



STEP 11

B		CB SCREW M3.5 X 12MM	6
C		CB SCREW M4 X 25MM	2
D		CB SCREW M4 X 35MM	8
F		POWER NAIL 6/8	6
U		DRAWER SLIDE 14"	1
J		MOON HANDLE C211	1
L		P/H SCREW M4 X 36MM	2

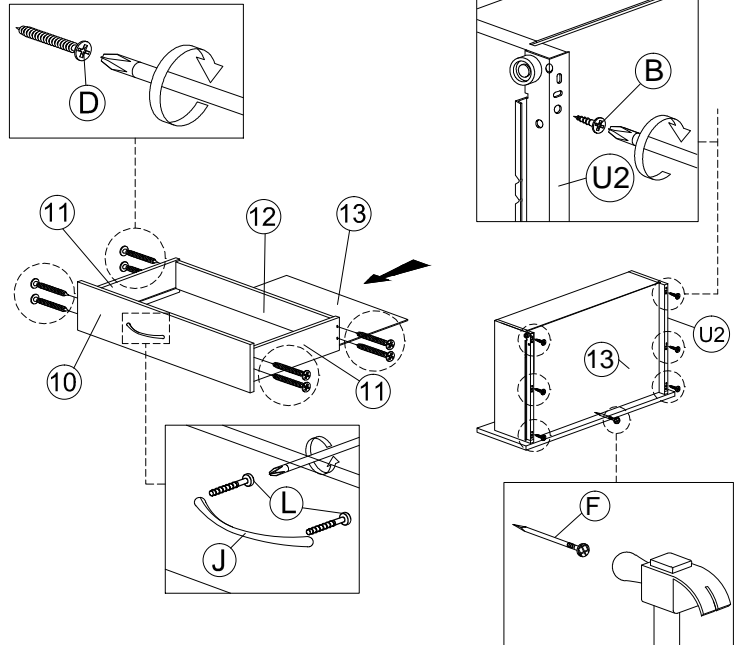
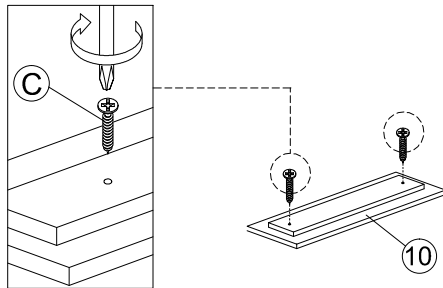

STEP 12

F		POWER NAIL 6/8	38
---	---	----------------	----

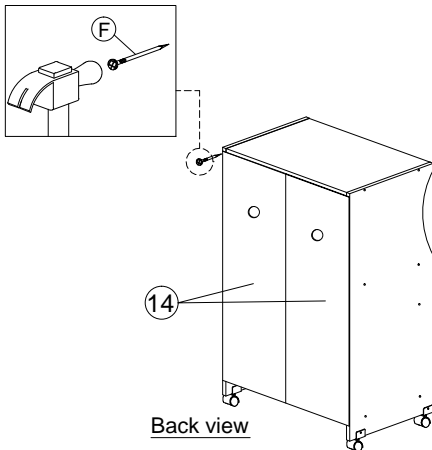

STEP 13

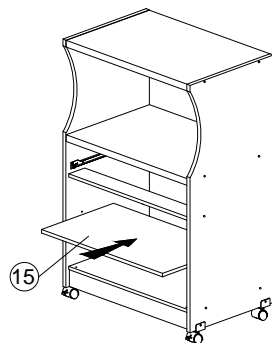

STEP 14

