

CHILDREN'S ELECTRONIC TOY TRACTOR

- Suitable for 3+ Years
- Maximum user weight: 30 kg



WARNING

The trailer of this product is only for decoration, passenger and loading are not allowed!



WARNING

Must be assembled by an adult.

OWNERS MANUAL

with Assembly Instructions

Read and understand this entire manual before using!

Please keep this manual for future reference as it contains important information. Before first time use, charge the battery for at least 4-6 hours, but no more than 10 hours.

On the purchase of your new Ride-On.

This ride-on car will provide your child with many miles of riding of enjoyment. To help assure you and your rider a safe ride we ask you to please read this manual carefully, and keep it for future reference.

Follow the recommendations in this manual, they are designed to improve the safety and operation of your ride-on car and its rider.

Specification

Battery	12V4.5AH X1	12V7AH X1	12V7AH X1
Charger input	12V500mA	12V700MA~1000MA	12V700MA~1000MA
	Depend on local voltage		
Motor	390-16000	390-16000	550-12000

Suitable age: 3+ Years

Charge time: 8~12 hours

Load capacity: Under 30 kg

Size of car: with trailer 1365 x 500 x 525 mm
without trailer 845 x 500 x 525 mm

Speed: 3-8 km/h



BATTERY INFORMATION

- Non-rechargeable batteries are not to be recharged.
- If removable rechargeable batteries are used, they are only to be charged under adult supervision.
- Remove rechargeable batteries from the product before charging.
- Do not mix old and new batteries. Do not mix different types of batteries: alkaline, standard (carbon-zinc) or rechargeable (nickel-cadmium).
- Insert batteries as indicated inside the battery compartment, anode to anode, cathode to cathode.
- Remove batteries during long periods of non-use. Always remove exhausted batteries from the product. Battery leakage and corrosion can damage this product. Dispose of batteries safely.
- Never short circuit the battery terminals.

Parts List

B

NO.	PART NAME	Q'TY (PCS)		REMARK
		WITHOUT TRAILER	WITH TRAILER	
1	Vehicle body	1	1	
2	Normal wheel	2	4	
3	Driving wheel	2	2	
4	Φ10 washer	2	4	
5	Lock nut	4	6	
6	Normal wheel hubcap	2	4	
7	Driving wheel hubcap	2	2	
8	Steering wheel	1	1	
9	Φ5 nut	1	1	
10	M5X30 machine screw	1	1	
11	Seat	1	1	
12	Φ4x12 flat head screw	5	5	
13	Trailer linkage	\	1	If equipped, for the trailer
14	Φ4x12 flat head screw	\	12	If equipped, for the trailer
15	Bushing	\	2	If equipped, for the trailer
16	Trailer axle	\	1	If equipped, for the trailer
17	Trailer bolt	\	1	If equipped, for the trailer
18	Trailer support	\	1	If equipped, for the trailer
19	Trailer house	\	1	If equipped, for the trailer
20	Side rail	\	2	If equipped, for the trailer
21	Front rail	\	1	If equipped, for the trailer
22	Exhaust pipe	1	1	
23	Spanner	2	2	
24	Charger	1	1	
25	Remote controller	1	1	If equipped
26	Φ8 washer	4	6	

Parts Diagram

Screwdriver
(not included)

Assembly tools required:

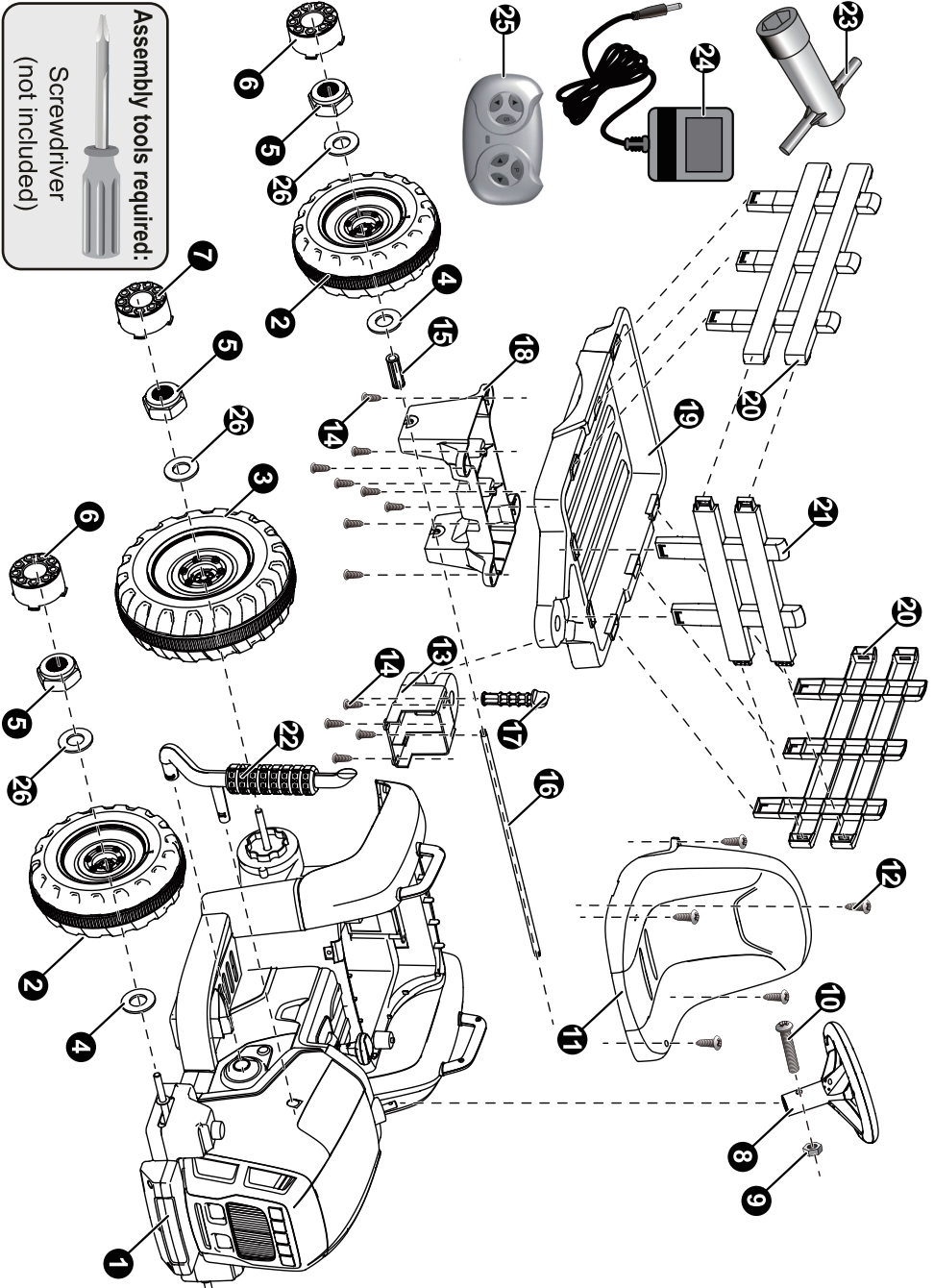

**PREVENT INJURIES AND DEATHS:**

- **NEVER LEAVE CHILD UNATTENDED. ADULT DIRECT SUPERVISION IS REQUIRED.** Always keep child in view when child is in vehicle.
- This toy should be used with caution since skill is required to avoid falls or collisions causing injury to the user or third parties.
- Protective equipment should be worn.
- Never use in roadways, near cars, or on near steep inclines or steps, swimming pools or other bodies of water.
- Always wear shoes, always sit on the seat.
- Not to be used in traffic.
- This toy is unsuitable for children under 36 months due to its maximum speed; Maximum user weight is 30 kg.
- This toy has no brake.

**WARNING:**

- **CHOKING HAZARD!** Not suitable for children under 36 months.
- **Must be assembled by an adult.**

Rules for Safe Riding

- Keep Children within Safe Riding Areas:
 - Never use in roadway, near motor vehicles, on lawn space, on or near steep inclines or steps, swimming pools or other bodies of water;
- Use the toy only on flat surfaces. Such as inside your house, garden or playground.
- Never use in the dark. A child could encounter unexpected obstacles and have an accident. Operate the vehicle only in the daytime or a well-lit area.
- It is prohibited to change the circuit or add other electric parts
- Inspect wires and connections of the vehicle periodically.
- Do not let any child touch the wheels or be near them when the car is moving .
- This vehicle has adjustable play seat belts. Please instruct children how to tie the safety belt before using, guarantee the security.

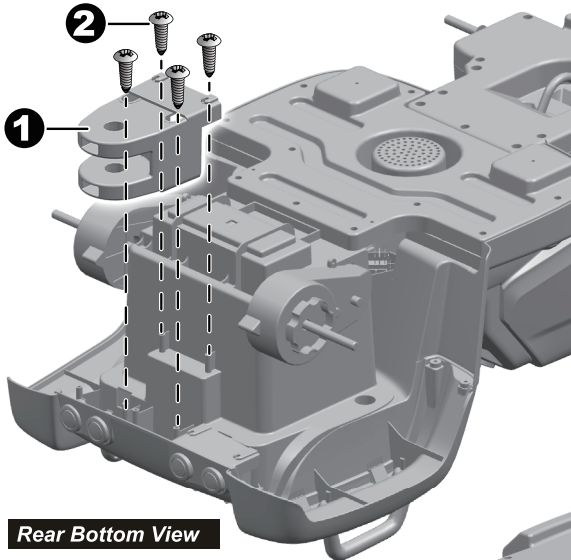
E**Attach the Trailer linkage & Driving wheel****Rear Bottom View**

Turn the vehicle body downside up.

1. Fit the trailer linkage to the vehicle body.
2. Insert four $\text{\O}4 \times 12$ flat head screws through the trailer linkage and into the vehicle body and tighten with a screwdriver.

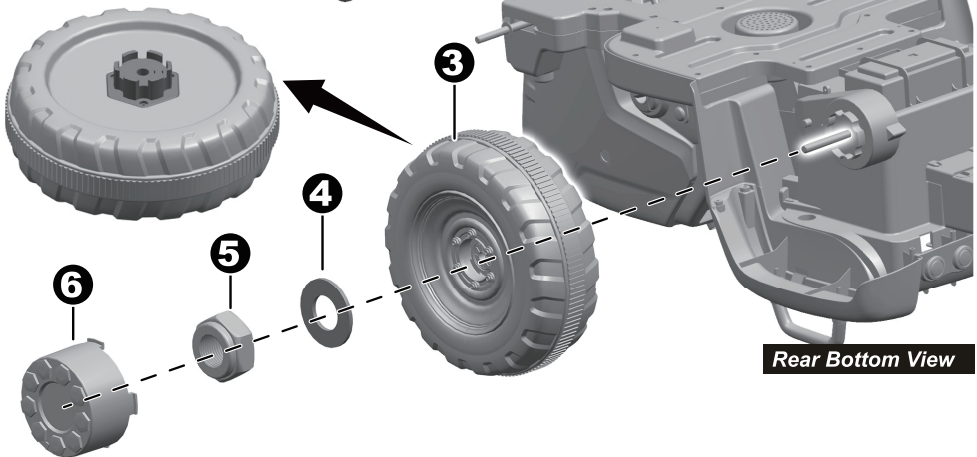
**Rear Bottom View**

3. Slide a driving wheel onto the rear axle. Ensure the driving wheel match up with gear box on the vehicle body.
 4. Slide a $\text{\O}8$ washer onto the rear axle.
 5. Tighten a lock nut to the end of the rear axle.
- Repeat steps 3-6 for the other driving wheel.
6. Insert the driving wheel hubcap to the driving wheel.

Attach the Rear Wheels & Steering Wheel

E

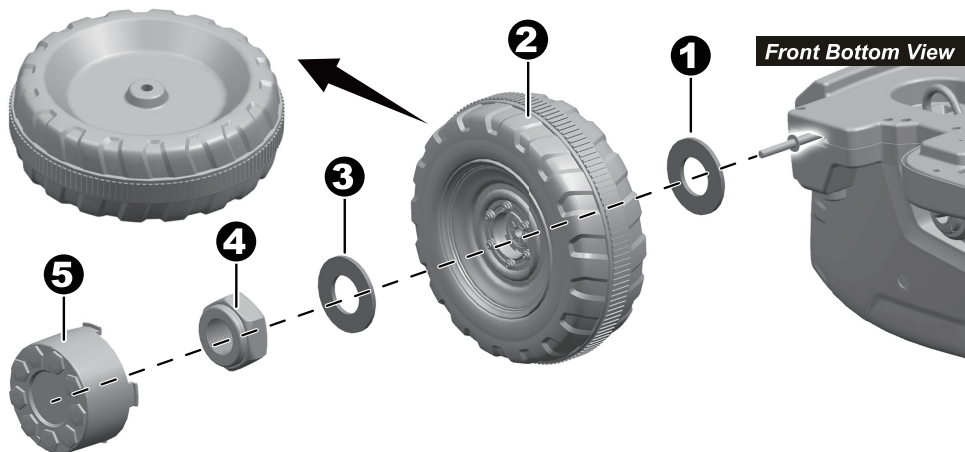

1. Slide a $\varnothing 10$ washer onto the front axle.
2. Slide a normal wheel onto the front axle.
3. Slide a $\varnothing 8$ washer onto the front axle.
4. Tighten a lock nut to the end of the front axle.
5. Insert the hubcap to the driving wheel.

Repeat for the other front wheel.

6. Fit the steering wheel to the end of the steering column.
7. Line up the holes on the steering wheel with the holes on the steering column, insert the M5x30 machine screw.
8. Fasten a nut on the opposite end of the screw with a screwdriver.

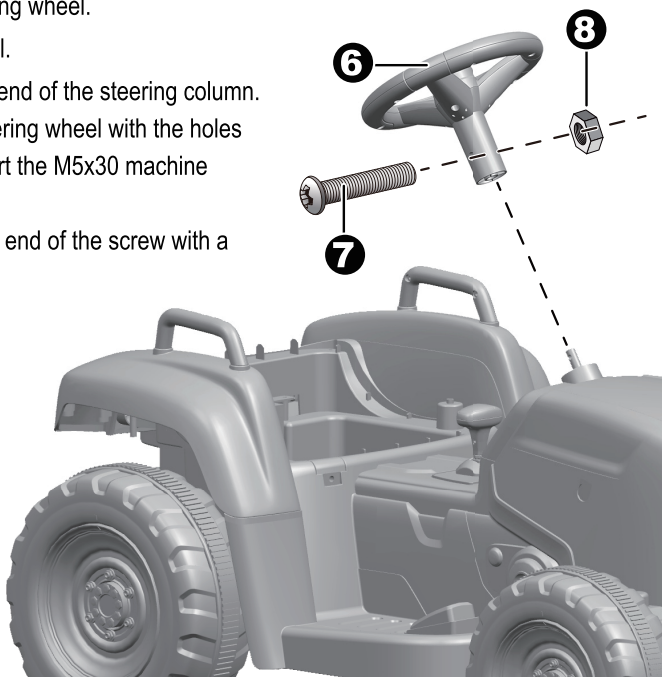

E**Attach the Exhaust Pipe & Connect the Power**

1. Fit the exhaust into the hole on the right side of the vehicle body, push until you hear it click into place.
2. Plug the red connector on the vehicle body into the red connector from the battery.

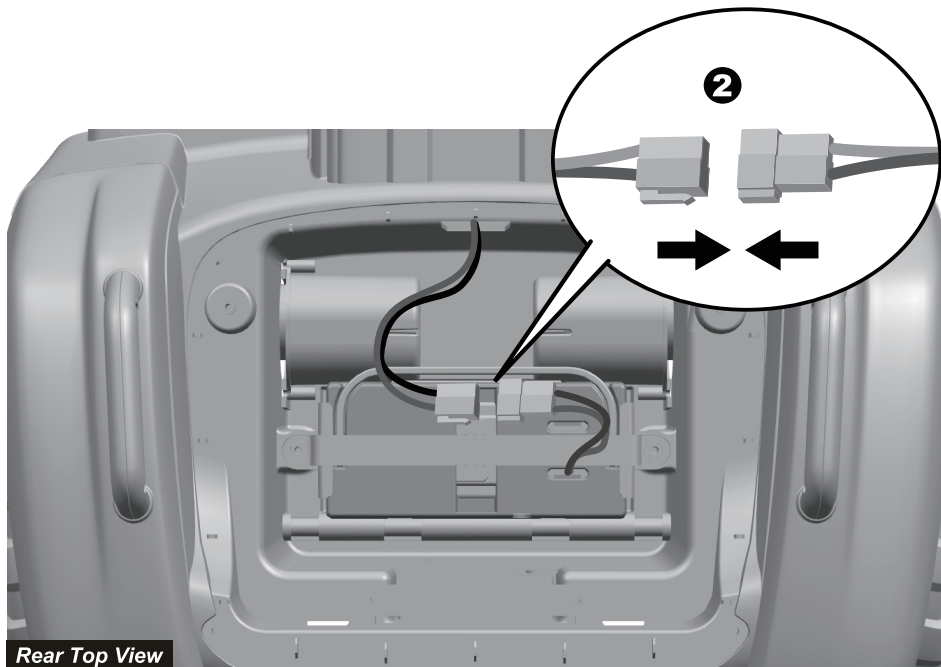
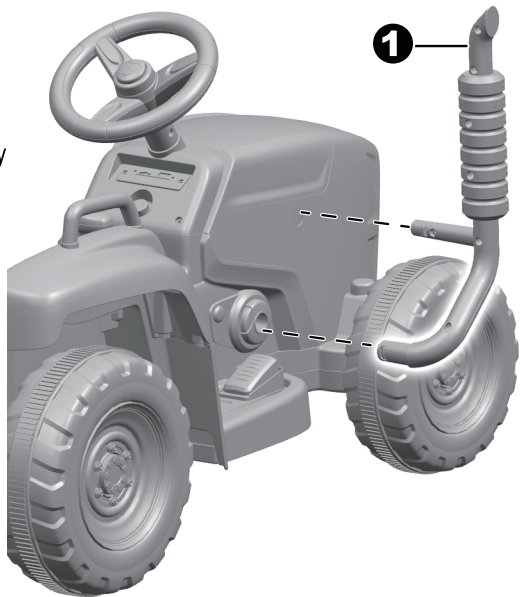
*Rear Top View*

Attach the Seat & the Trailer

E

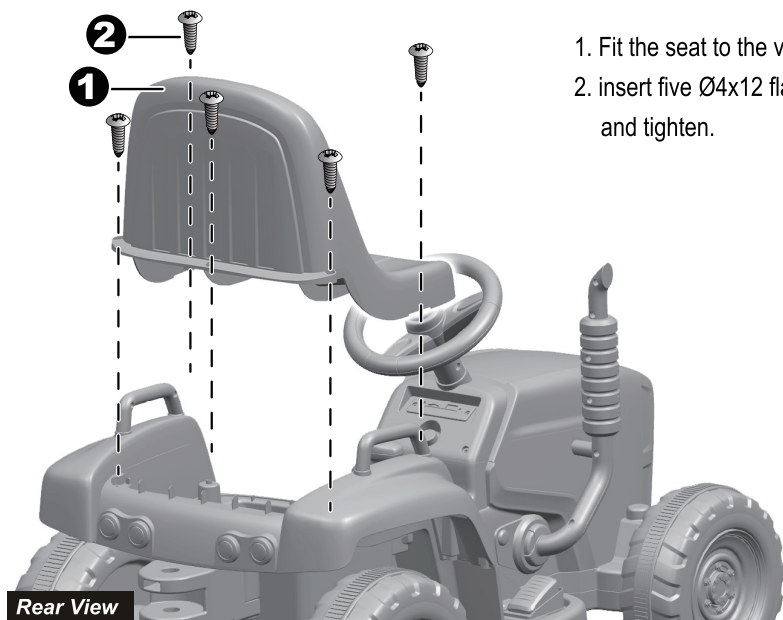

1. Fit the seat to the vehicle body.
2. insert five Ø4x12 flat head screws and tighten.

Attach the Trailer (if equipped)

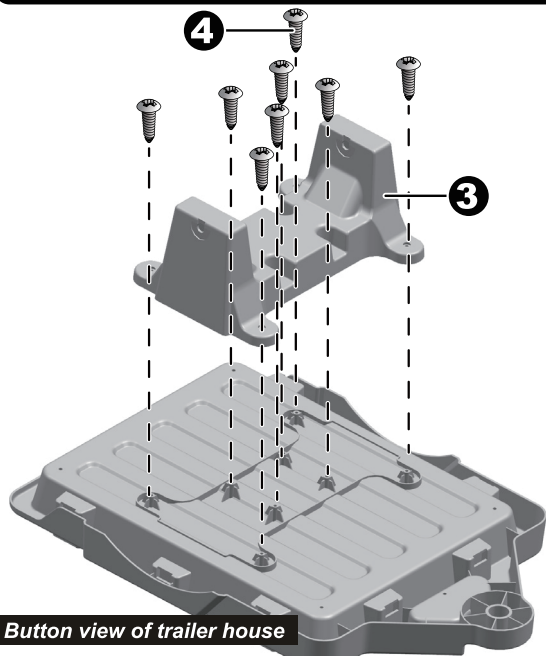

- Turn the trailer house downside up.
3. Fit the trailer support to the trailer house.
 4. insert eight Ø4x12 flat head screws and tighten.

E**Attach the Rails & Trailer Wheel (if equipped)**

Turn over the trailer house

1. Fit the side rails to the front rail
2. Fit the rails assembly to the trailer hours.

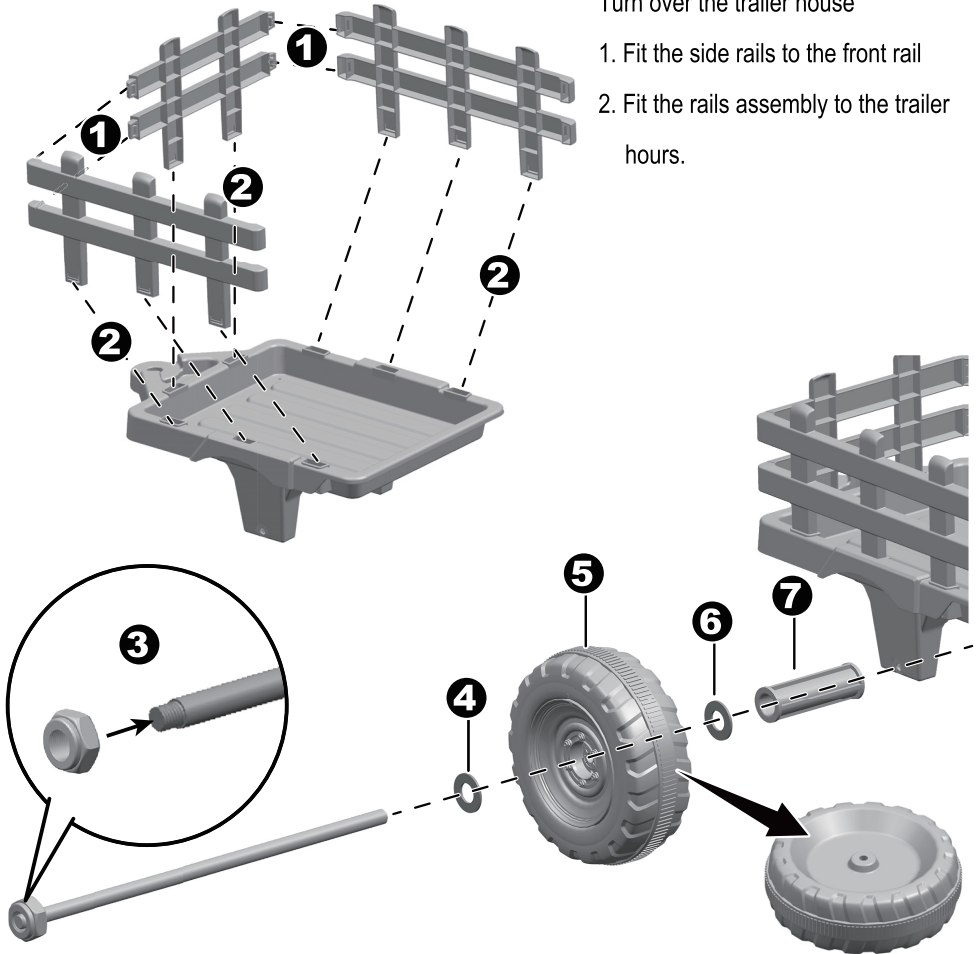

3. Tighten a locknut to the end of trailer axle.
4. Slide a $\text{Ø}8$ washer onto the trailer axle.
5. Slide a normal wheel (out side first) on the trailer axle.
6. Slide a $\text{Ø}10$ washer onto the trailer axle.
7. Slide bushing on the trailer axle.
8. Insert the trailer axle passes through the holes on the one side of the trailer support, and out through the holes on the other side of the trailer support.

Attach the Trailer to Vehicle body (if equipped)

E

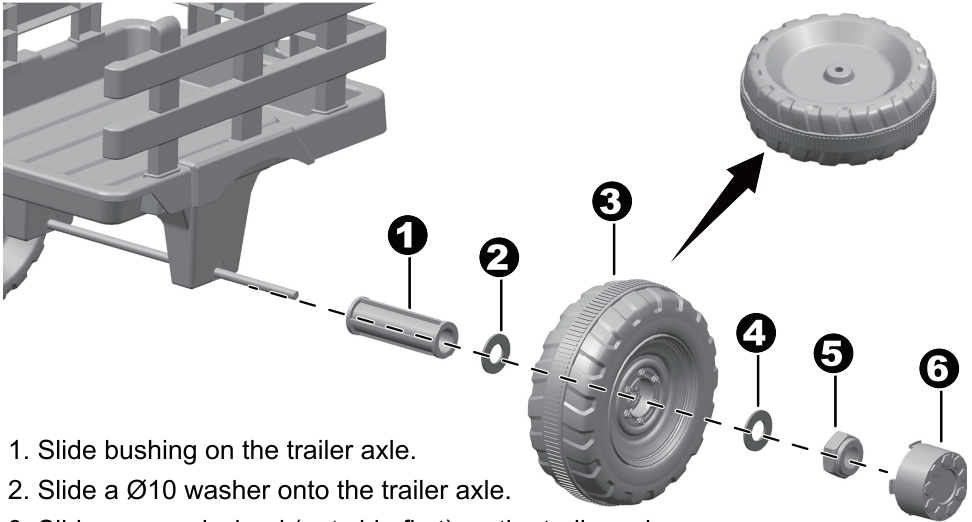

1. Slide bushing on the trailer axle.
2. Slide a $\varnothing 10$ washer onto the trailer axle.
3. Slide a normal wheel (out side first) on the trailer axle.
4. Slide a $\varnothing 8$ washer onto the trailer axle.
5. Tighten a locknut to the end of trailer axle with a spanner.

Hint: An extra spanner has been provided to hold the lock nut on the other side of the trailer axle while tightening the lock nut on the other side.

6. Insert the normal wheel hubcaps to the wheels.

7. Fit the trailer assembly to the trailer linkage on the vehicle body.
8. Insert the trailer bolt and push until you hear it "click" into place.

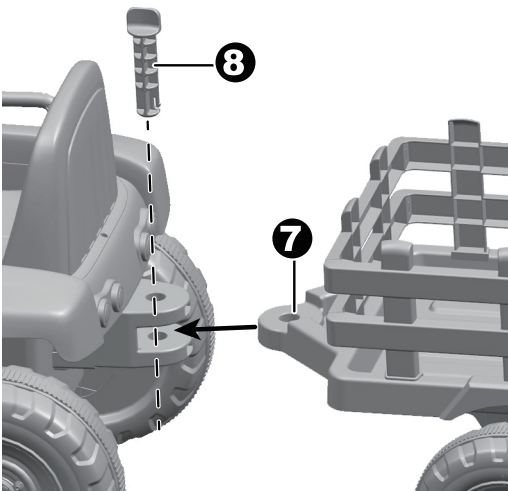

**IMPORTANT!**

Always stop vehicle when changing the speed or direction to avoid damage the gears and motor.

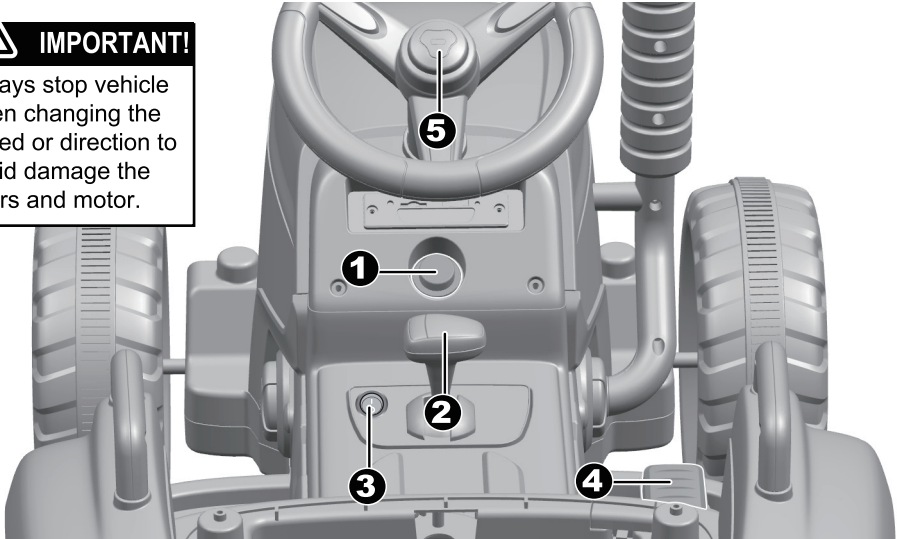

1. **One button start:** Turns the vehicle on and off.

2. **High / Low speed forward & Reverse shift:**

Changes the direction that vehicle moves from forward to reverse.

- To move the vehicle forward in high speed, shift the lever to top position
- To move the vehicle forward in low speed, shift the lever to middle position
- To move the vehicle backward, shift the lever to down position

HINT: The vehicle is designed to operate in low speed only in reverse.

3. **Lights switch:** Turns the vehicle lights on and off.

4. **Foot pedal:**

- To move the vehicle, press the pedal down.
- To brake or slow down, release pressure from the pedal.

5. **Horn button:** Press for horn or sound playing.

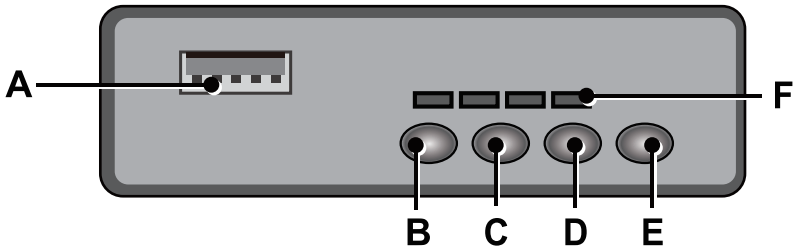

A. USB slot (Maximum support 15GB)

B. Change to the USB music play or Bluetooth:YJ-XLHP-BT

C. Play / Next

D. Decrease volume

E. Increase volume

F. Battery display: It displays the power level of the battery when the vehicle stops. When one indicator remains, recharge the battery please.

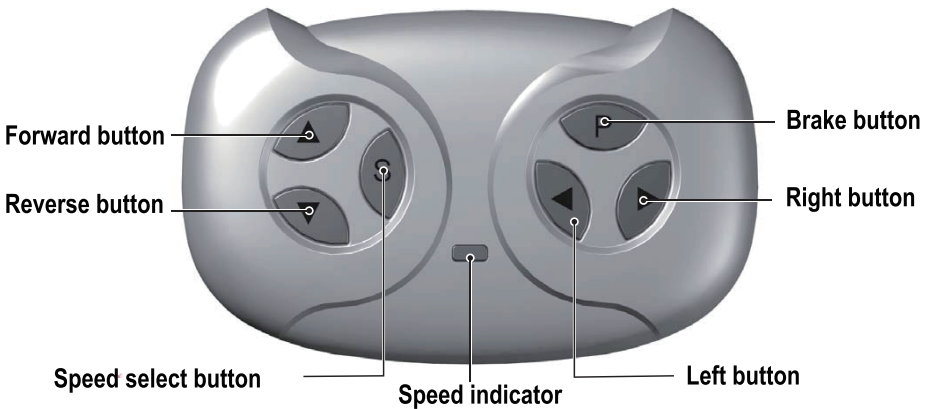

Attach the batteries of controller

Lift the battery compartment door on the back of the controller and insert two AAA(LR03) batteries.

HINT: Batteries not included. Refer to the Battery Information on the page 1.

1. Build connection

Long press the forward and reverse buttons for 3 seconds, and the speed indicator flashes. Then power on the vehicle, the speed indicator goes to long bright, means the connection successful. If the speed indicator no response, means the connection failed. Replace the batteries and retry.

2. Brake button

Press the button to stop the vehicle, press it again to release the brake.

3. Speed select button

The switch operates the vehicle to move in low, normal or high speed.

HINT: This switch won't work while your vehicle moves reverse.

NOTE:

- Leave the remote controller idling for about 10 seconds, it will shut down automatically.
- Rebuild connection when you replace the batteries of the remote controller.

**WARNING!**

ONLY AN ADULT CAN CHARGE AND RECHARGE THE BATTERY!

**WARNING!**

This product with **Charging Protection**: when charging, all functions will be cut off! Only an adult can charge and recharge the battery!

- The POWER SWITCH must be turned in **OFF** position when charging.
- Before the first use, you should charge the battery for 4-6 hours. Do not recharge the battery for more than 10 hours to avoid overheating the charger.
- When the vehicle begins to run slowly, recharge the battery.
- After each use or once a month minimum recharge time as 8 to 12 hours, less than 20 hours at most.
- Use the only rechargeable battery and charger supplied with your vehicle. **NEVER** substitute the battery or the charger with another brand. Using another battery or charger may cause a fire or explosion.
- Do not use the battery or charger for any other product.

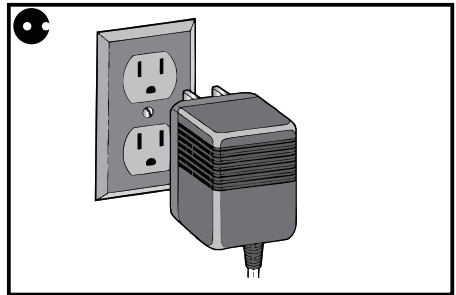
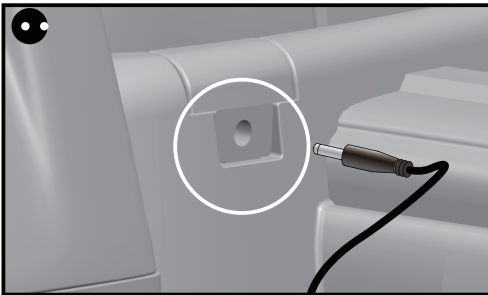

1. Plug the charger port into the input socket. (below the seat)
2. Plug the charger plug into a wall outlet. The battery will begin charging.

Problem	Possible Cause	Solution
Vehicle does not run	Battery low on power	Recharge battery.
	Thermal fuse has tripped	Reset fuse, see <Fuse>
	Battery connector or wires are loose	Check that the battery connectors are firmly plugged into each other. If wires are loose around the motor contact your distributor please.
	Battery is dead	Replace battery, contact your distributor please.
	Electrical system is damaged	Contact your distributor please.
	Motor is damaged	Contact your distributor please.
Vehicle does not run very long	Battery is under charged	Check that the battery connectors are firmly plugged into each other when recharging
	Battery is old	Replace battery, contact your distributor please.
Vehicle runs sluggishly	Battery low on power	Recharge battery, contact your distributor please.
	Battery is old	Replace battery, contact your distributor please.
	Vehicle is overload	Reduce weight on vehicle.
	Vehicle is being used in harsh conditions	Avoid using vehicle in harsh conditions ,see <Safety>.
Vehicle needs a push to go forward	Poor contact of wires or Connectors	Check that the battery connectors are firmly plugged into each other. If wires are loose around the motor, contact your distributor please.
	“Dead Spot” on motor	A dead spot means the electric power is not being delivered to the terminal connection and the vehicle needs repair. Contact your distributor please.
Difficult shifting from forward to reverse or vice-versa	Attempting to shift while the vehicle is motion	Completely stop the vehicle and shift, see <Use Your New Vehicle>
Loud grinding or clicking noises coming from motor or gear box	Motor or gears are damaged	Contact your distributor please.
Battery will not recharge	Battery connector or adapter connector is loose	Check that the battery connectors are firmly plugged into each other.
	Charger not plugged in	Check that the battery charger is plugged into a working wall outlet.
	Charger is not working	Contact your distributor please.
Charger feels warm when recharging	This is normal and not a cause for concern	

Completely read through this manual and the troubleshooting guide table before calling. If you still need help resolving the problem **Contact your distributor please.**

- It is parents' responsibility to check main parts of the toy before using, must regularly examine for potential hazard, such as the battery, charge, cable or cord, plug, screws are fastening enclosure of other parts and that in the event of such damage, the toy must not be used until that damage had been properly removed.
- Make sure the plastic parts of the vehicle are not cracked or broken.
- Occasionally use a lightweight oil to lubricate moving parts such as wheels.
- Park the vehicle indoors or cover it with a tarp to protect it from wet weather.
- Keep the vehicle away from sources of heat, such as stoves and heaters. Plastic parts may melt.
- Recharge the battery after each use. Only an adult can handle the battery. Recharge the battery at least once a month when the vehicle Raider is not being used.
- Do not wash the vehicle with a hose. Do not wash the vehicle with soap and water. Do not drive the vehicle in rainy or snowy weather. Water will damage the motor, electric system and battery.
- Clean the vehicle with a soft, dry cloth. To restore shine to plastic parts, use a non-wax furniture polish. Do not use car wax. Do not use abrasive cleaners.
- Do not drive the vehicle in loose dirt, sand or fine gravel which could damage the moving parts, motors or the electric system.
- When not using, all the electrical source should be turn off. Turn off the power switch and disconnect the battery connection.

The battery features a thermal fuse with a reset fuse that will automatically trip and cut all power to the vehicle if the motor, electric system or battery is overloaded. The fuse will reset and power will be restored after the unit is turned OFF for 20 seconds and then turned ON again. If the thermal fuse trips repeatedly during normal use, the vehicle may need repair. **Contact your distributor please.**

To avoid losing power, follow these guidelines:

- Do not overload the vehicle.
- Do not tow anything behind the vehicle.
- Do not drive up steep slopes.
- Do not drive into fixed objects, which may cause the wheels to spin, causing the motor to overheat.
- Do not drive in very hot weather, components may overheat.
- Do not allow water or other liquids to come in contact with the battery or other electric components.
- Do not tamper with the electric system. Doing so may create a short, causing the fuse to trip.

Disposal Of Battery



- Your sealed lead-acid battery must be recycled or disposed of in an environmentally sound manner.
- Do not dispose of your lead-acid battery in a fire. The battery may explode or leak.
- Do not dispose of a lead-acid battery in your regular, household trash. The incineration, land filling or mixing of sealed lead-acid batteries with household trash is prohibited by law.

Our products are suitable for ASTM F963; GB6675; EN71 and EN62115 standard.