



# TABLE OF CONTENTS

---

## English

Introduction.....	3
Versai Fence Options.....	4
Fence Layout.....	6
Post Installation.....	10
Bracket Installation.....	11
Panel Cutting.....	16
Panel Installation.....	19
Pressed Dome Cap Installation.....	20
Care & Maintenance/ Warranty.....	22

## INTRODUCTION

---

### READ INSTRUCTIONS COMPLETELY BEFORE STARTING INSTALLATION

It is the responsibility of the installer to meet all code and safety requirements, and to obtain all required building permits. The fencing installer should determine and implement appropriate installation techniques for each installation situation. Fortress Building Products and its distributors shall not be held liable for improper or unsafe installations.

#### Before You Begin

Contact your local Building Code Department for required permits and laws regarding your fence project.

If applicable, also contact your Home Owners Association for rules and regulations regarding fence installations in your neighborhood.

**Call 811 before you dig post holes to locate and identify any buried utilities.**

#### Note

- When cutting Fortress Fencing, it is very important to complete the following at cut points:
- Remove all metal shavings from the cut area.
- File any sharp edges left by cutting. Thoroughly wipe and remove any filings, grime, or dirt.
- Apply two coats of Fortress zinc based touch-up paint to the cut area. If touch up is at rail ends, allow paint to dry before connecting bracket to post.
- Be sure to remove any metal shavings from the surface of Fence.

#### Torx Safety Tips

- Always use the lowest speed setting on drill.
  - To reduce chance of bit breakage, start tightening with drill on low torque setting and work up until screw is secured.
- Tip: Pre-drill holes with 5/32" [4mm] drill bit.**

## Required Tools



Goggles



Safety  
Gloves



Tape  
Measurer



Speed  
Square



Level  
Tool



Fortress  
Touch-up Paint



Bit  
Extender



Socket  
Set



Nut Driver Bits: 5/16"  
[9mm], [13mm]



#2 Phillips  
Head Bit



Drill Bits: 5/16" [8mm],  
5/32" [4mm]



Drill



Pliers



Ground  
Stakes



String



Pencil



Spring  
Punch



Rubber  
Mallet



Wheelbarrow



Spade  
Shovel



Concrete/  
Gravel



Reciprocating Saw  
or Portable Bandsaw



Post Hole  
Digger

## VERSAI FENCE OPTIONS

### Posts

- Versai Fence posts are available as 2" [50mm] square, 16 gauge [1.6mm] in lengths of 72" [1828mm], 84" [2133mm], 108" [2743mm] and 96" [2438mm].



2" x 2" [50mm x 50mm]

### Gate Uprights

- Versai Fence Gate Uprights are 1-1/2" [38mm] square, 16 gauge [1.6mm], which matches the height of the gate.



1-1/2" x 1-1/2" [38mm x 38mm]

## Panel & Gate Styles

- All Versai Fence Panels have matching Flat & Arched Walk Gates in widths of 46-1/2" [1181mm] & 58-1/2" [1485mm]. Drive Gates are available in 72" [1828mm] width Flat Drive Gates as well as 96" [2438mm] Arched & Flat Drive Gates.
- All Versai Fence Panels are rackable to 48" [1219mm].

### Note:

2 and 3 Rail options are available.

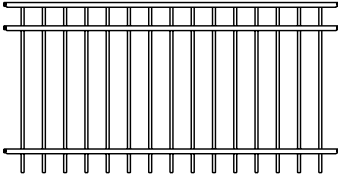

FLAT TOP VERSAI

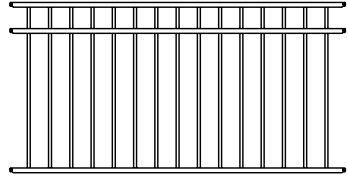

FLAT TOP/FLAT BOTTOM VERSAI

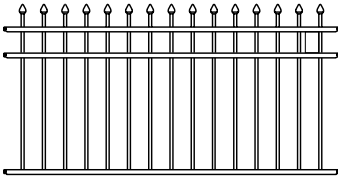

SPEAR POINT/FLAT BOTTOM VERSAI

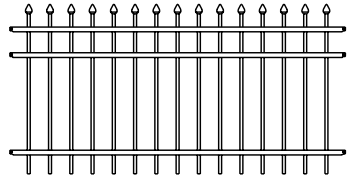

SPEAR POINT VERSAI

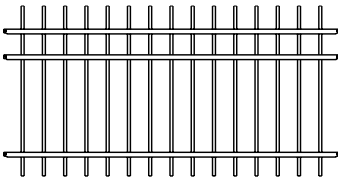

EXTENDED PICKET VERSAI

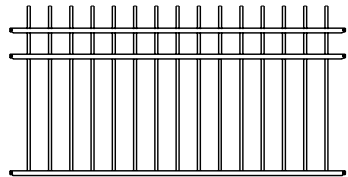

EXTENDED/FLAT BOTTOM VERSAI

## Bracket Options

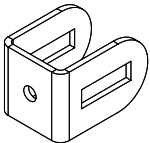

EX-104

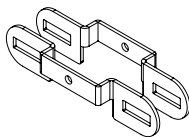

EXW-204

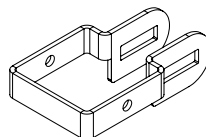

EXW-304

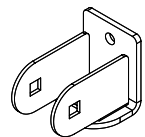

EXS-104

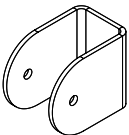

OMNI-104

## FENCE LAYOUT

### Step 1: Sketch Layout of Fence Perimeter

1. Identify the property line and determine the perimeter of your fence project.
2. Using a tape measure determine the length of each fence run.
3. Versai Fence is easiest to install when starting from a corner. If no gates are used, only one panel should need to be cut. (**2" [50mm] Post Max On Center Spacing is 92-3/8" [2346mm]**).
4. If using 2" [50mm] Posts divide the length of a fence run by 92-3/8" [2346mm] that will tell you how many post are required for that run.
5. Determine the location of gates and mark on drawings. Adjustments to panel length are required at gates.

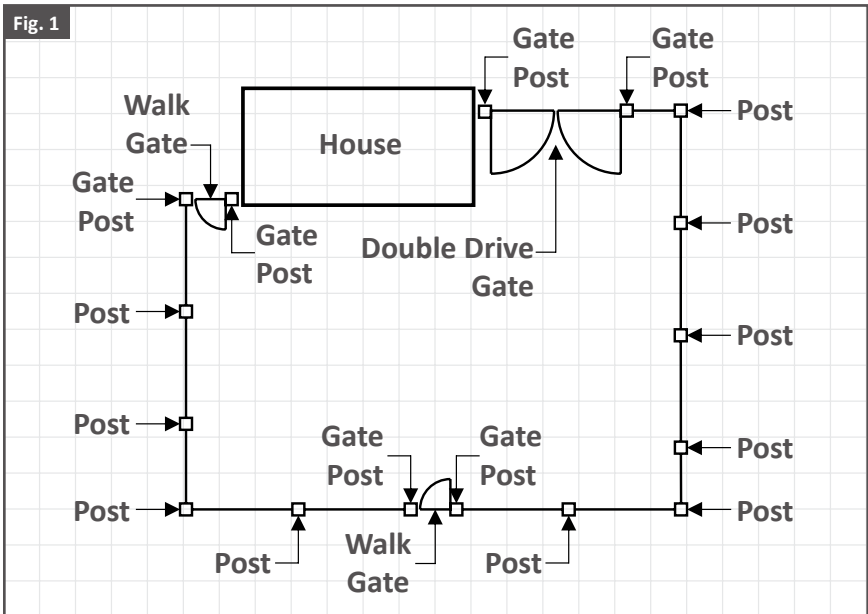

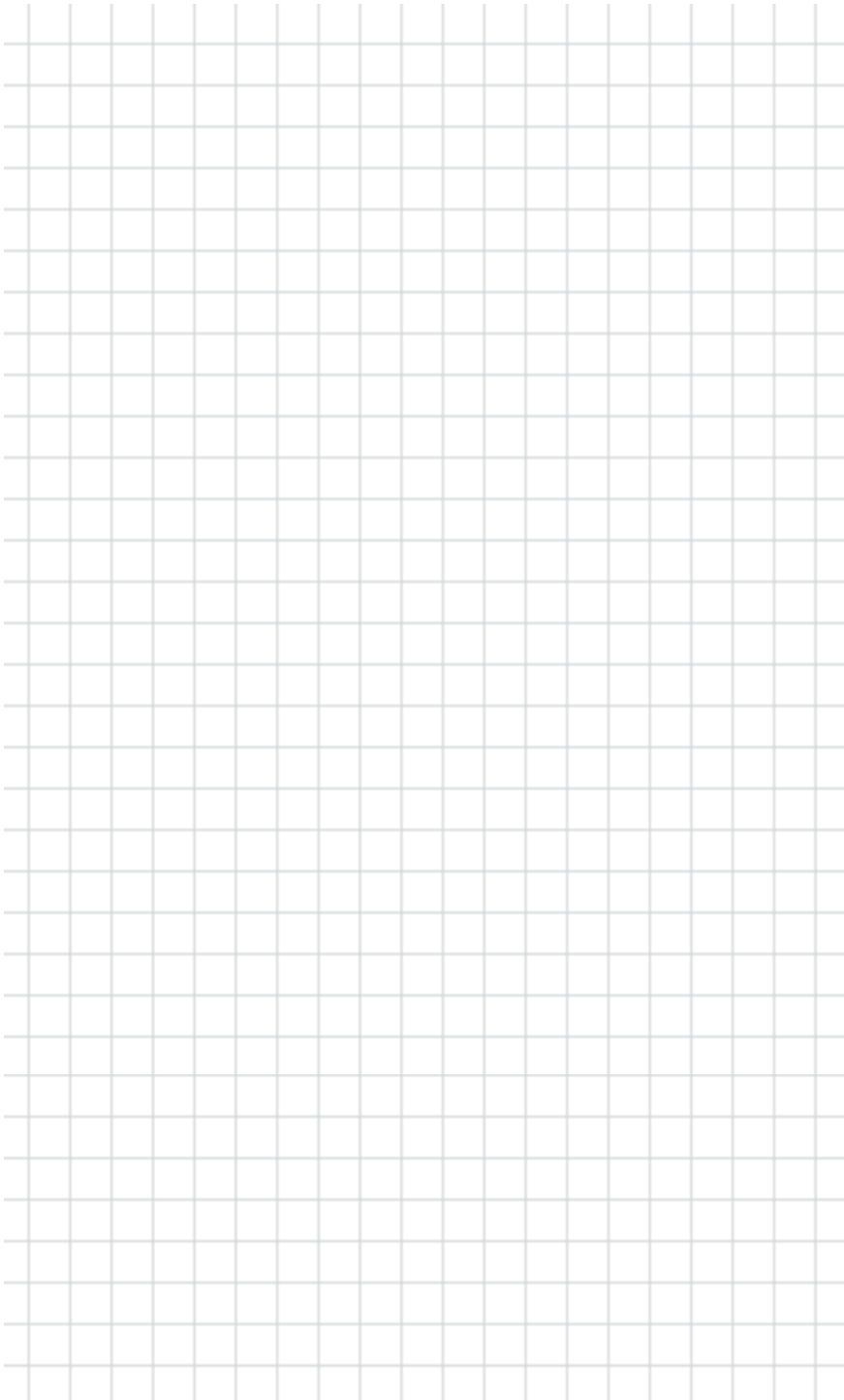

## Step 2: Use Stakes & String to Create Perimeter

1. Using the fence layout sketch as a guide, locate a corner or reference point along each fence run and mark it with a stake.
2. Use a string stretched between stakes located at the end of each fence run, and layout the perimeter of the fence project.
3. Layout fence so that minimal panel cuts are required; remember to allow for gates.
4. If layout has 90° corners, confirm that corners form 90° angles.

### Note:

- **(2" [50mm] Post Max On Center Spacing is 92-3/8" [2346mm]).**

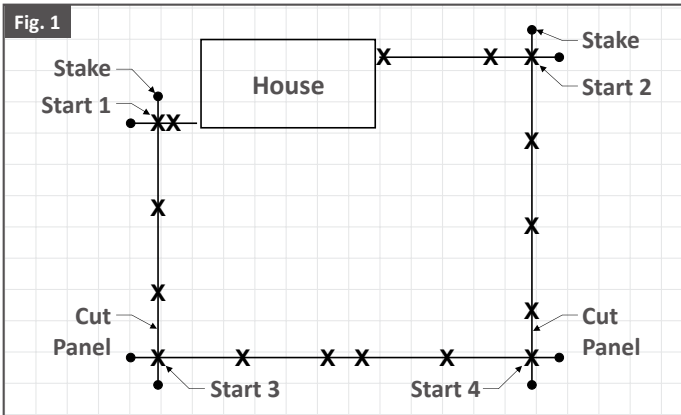

## Step 3: Dig Post Holes

1. From starting point, use a tape measure to mark post hole.
2. Use the Post Hole Digger to dig the holes to be 27" [685mm] deep and 8" [203mm] in diameter. As shown in Fig. 2.
3. Keep Post Hole Digger straight and plumb.

### Note:

- Call 811 before you dig post holes to locate and identify any buried utilities.
- Post holes should be at least 8" [203mm] in diameter, however you should always consult local code requirements for exact requirements.



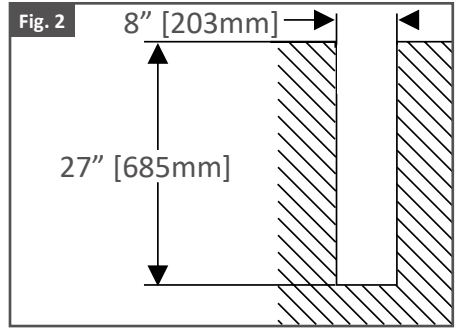
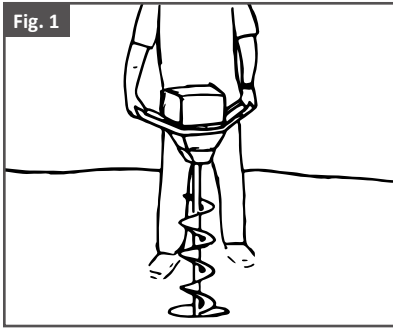

#### Step 4: Set Posts

1. Fill holes with 3" [72mm] of pea gravel or crushed stone to allow for drainage. As shown in Fig. 1.
2. Compact the gravel before setting post.
3. Use tape measure to check depth. Versai Fence posts are designed to be buried 24" [609mm] deep. As shown in Fig. 2.
4. Use the string as a guide when placing posts in each hole. As shown in Fig. 3.

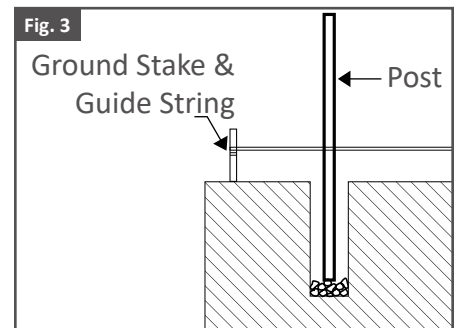
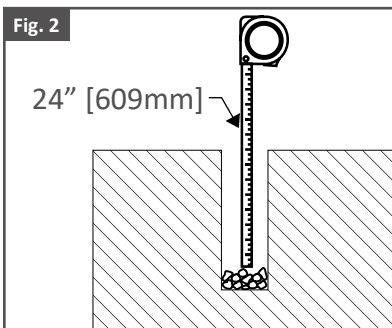
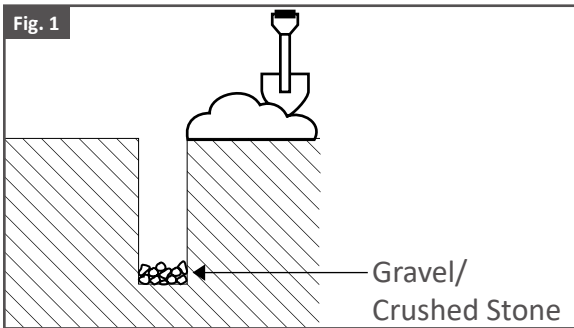

## POST INSTALLATION

### Step 1: Install Post

1. Confirm post hole depth.
2. Remove or add gravel to set post hole depth at 24" [609mm].
3. Position post along guide string. As shown in Fig. 1.

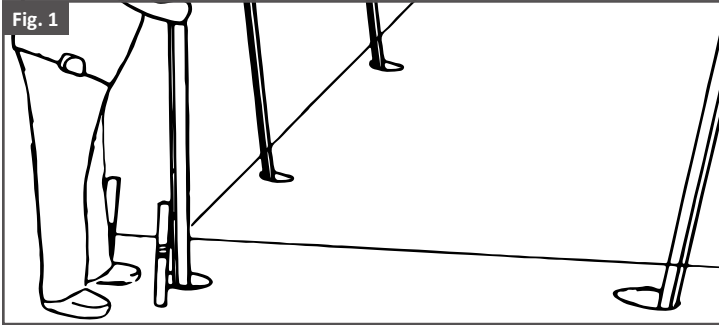

### Step 2: Pour Concrete

1. Fill Posts holes with concrete to within 1" [25mm] of the surface of soil. As shown in Fig. 1.
3. Use a level to confirm that corner post is plumb and that the post is aligned with the Guide Strings.

#### Tip:

- Allow concrete to cure for a minimum of 24 hours before installing brackets.
- As the concrete cures, be sure to keep posts placed along guide strings & continuously check that they are plumb as well as in line with the next post.

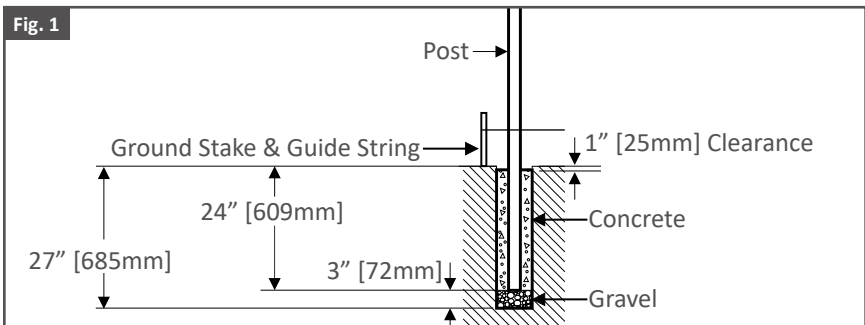

## BRACKET INSTALLATION

---

### Bracket Details:

\*Reference Bracket & Rail Options on page 5.

- **End Bracket (EX-104)** - This bracket can be used in all applications for Versai Fence. The bracket mounts on the inside face of the post.
- **Swivel Bracket (EXS-104)** - This bracket is designed to be utilized for angled panel installation. The bracket mounts on the inside face of the post. Maximum angle is 30°.
- **Line Bracket (EXW-204)** - Utilizing this bracket is one of the easiest ways of installing the Versai Fence. Once the post is installed in concrete and set, install an EXW-204 Bracket on each end of a panel with the bracket centered in the post of the bracket. Lightly tighten the Bracket Bolt/Nut to hold the panel in place. Complete this step for each of the rails on the panel. After all panels have been installed using this method, return to your starting point. Using a 2" X 4" X 72" [50mm x 101mm x 1829mm] as a lever, insert the board under the bottom of the picket closest to the post and gently pry up on the picket. This will adjust the height of the panel to the needed height. With the pry board in place and the panel height set, tighten the Bracket Bolt/Nut. Once all panels have been leveled and fasteners tightened, using the 10mm Nut Driver, install the Self-Tapping Screws into the designated holes on each side of the bracket.

#### **Note:**

**DO NOT** over tighten the Bracket Bolt/Nut or the Self-Tapping Screw.

- **Corner Bracket (EXW-304)** - This bracket was designed to be used for Corner Post Installation.

When installing this bracket, the brackets must be slid over the top of the post prior to installing any panels, in the direction they will be installed. This is a bracket that has a fixed position on the post and change of direction is not possible once panel installation begins. For installation of this bracket, the set up laid out for the EXW-204 Bracket can be utilized in the same manner by attached the panel to the bracket initially, then installing the Self-Tapping Screw at the end of the process. When positioning the brackets on the post, the bottom bracket (of each panel connection) should be installed upside down. This ensures that the rails line up for the direction change.

### Step 1: Mark Bracket Hole Locations For EX-104 & EXS-104

1. Mark the centerline of each post with a pencil.
2. Take measurements used in Fig. 1 - 9 to mark top, middle & bottom bracket hole locations onto posts.

#### Tip:

- Remove all metal shavings from posts before brackets are installed to post to prevent rust stains & prevent corrosion.

#### Note:

- All panels should be installed with the bottom face of the bottom rail a minimum of 2" [50mm] above ground surface.

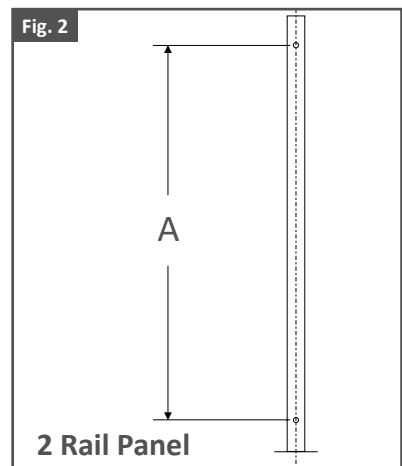
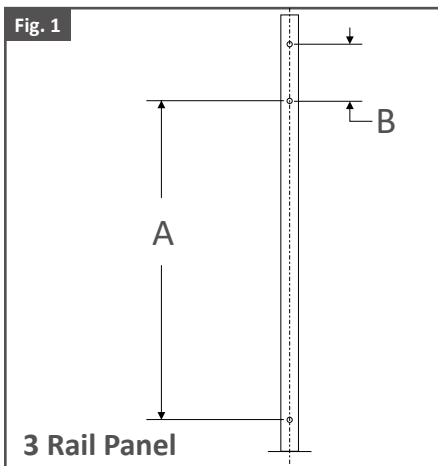

**Fig. 3****Bracket Hole Locations: 34" [864mm] Panel**

Pre-drill Dimensions: Pre-drilling with a 5/32" [4mm] drill bit is required

**3 Rail Panel**

	A	B
<b>FT3, SP3, EXT3</b>	23-3/4" [603mm]	5-1/16" [128mm]
<b>FT-FB3, SP-FB3, EXT-FB3</b>	27-3/4" [694mm]	5-1/16" [128mm]

**2 Rail Panel**

	A	B
<b>FT2, SP2, EXT2</b>	28-13/16" [731mm]	N/A
<b>FT-FB2, SP-FB2, EXT-FB2</b>	32-13/16" [831mm]	N/A

\*Bottom surface of the bottom Rail has a min. spacing of 2" [50mm] above ground surface.

**Fig. 4****Bracket Hole Locations: 40" [1016mm] Panel**

Pre-drill Dimensions: Pre-drilling with a 5/32" [4mm] drill bit is required

**3 Rail Panel**

	A	B
<b>FT3, SP3, EXT3</b>	27-3/4" [694mm]	5-1/16" [128mm]
<b>FT-FB3, SP-FB3, EXT-FB3</b>	33-3/4" [857mm]	5-1/16" [128mm]

**2 Rail Panel**

	A	B
<b>FT2, SP2, EXT2</b>	34-13/16" [884mm]	N/A
<b>FT-FB2, SP-FB2, EXT-FB2</b>	38-13/16" [985mm]	N/A

\*Bottom surface of the bottom Rail has a min. spacing of 2" [50mm] above ground surface.

**Fig. 5****Bracket Hole Locations: 46" [1168mm] Panel**

Pre-drill Dimensions: Pre-drilling with a 5/32" [4mm] drill bit is required

**3 Rail Panel**

	A	B
<b>FT3, SP3, EXT3</b>	33-3/4" [857mm]	5-1/16" [128mm]
<b>FT-FB3, SP-FB3, EXT-FB3</b>	39-3/4" [1009mm]	5-1/16" [128mm]

**2 Rail Panel**

	A	B
<b>FT2, SP2, EXT2</b>	40-13/16" [1036mm]	N/A
<b>FT-FB2, SP-FB2, EXT-FB2</b>	44-13/16" [1138mm]	N/A

\*Bottom surface of the bottom Rail has a min. spacing of 2" [50mm] above ground surface.

**Fig. 6****Bracket Hole Locations: 48" [1219mm] Panel**

Pre-drill Dimensions: Pre-drilling with a 5/32" [4mm] drill bit is required

**3 Rail Panel: N/A****2 Rail Panel**

	A	B
<b>FT2, SP2, EXT2</b>	N/A	N/A
<b>FT-FB2</b>	46-13/16" [1189mm]	N/A
<b>SP-FB2, EXT-FB2</b>	N/A	N/A

\*Bottom surface of the bottom Rail has a min. spacing of 2" [50mm] above ground surface.

**Fig. 7****Bracket Hole Locations: 54" [1372mm] Panel**

Pre-drill Dimensions: Pre-drilling with a 5/32" [4mm] drill bit is required

**3 Rail Panel**

	A	B
<b>FT3, SP3, EXT3</b>	41-3/4" [1060mm]	5-1/16" [128mm]
<b>FT-FB3, SP-FB3, EXT-FB3</b>	47-3/4" [1202mm]	5-1/16" [128mm]

**2 Rail Panel: N/A**

\*Bottom surface of the bottom Rail has a min. spacing of 2" [50mm] above ground surface.

**Fig. 8****Bracket Hole Locations: 58" [1473mm] Panel**

Pre-drill Dimensions: Pre-drilling with a 5/32" [4mm] drill bit is required

**3 Rail Panel**

	A	B
<b>FT3, SP3, EXT3</b>	45-3/4" [1162mm]	5-1/16" [128mm]
<b>FT-FB3, SP-FB3, EXT-FB3</b>	51-3/4" [1314mm]	5-1/16" [128mm]

**2 Rail Panel**

	A	B
<b>FT2, SP2, EXT2</b>	52-13/16" [1341mm]	N/A
<b>FT-FB2, SP-FB2, EXT-FB2</b>	56-13/16" [1443mm]	N/A

\*Bottom surface of the bottom Rail has a min. spacing of 2" [50mm] above ground surface.

**Fig. 9****Bracket Hole Locations: 70" [1778mm] Panel**

Pre-drill Dimensions: Pre-drilling with a 5/32" [4mm] drill bit is required

**3 Rail Panel**

	A	B
<b>FT3, SP3, EXT3</b>	57-3/4" [1466mm]	5-1/16" [128mm]
<b>FT-FB3, SP-FB3, EXT-FB3</b>	63-3/4" [1619mm]	5-1/16" [128mm]

**2 Rail Panel**

	A	B
<b>FT2, SP2, EXT2</b>	64-13/16" [1646mm]	N/A
<b>FT-FB2, SP-FB2, EXT-FB2</b>	68-13/16" [1748mm]	N/A

\*Bottom surface of the bottom Rail has a min. spacing of 2" [50mm] above ground surface.

## Step 2: Pre-Drill and Install Brackets

### Tip:

- **It's important to double check dimensions to confirm accuracy of bracket hole locations before drilling.**
1. Use Spring Punch to mark the holes. As shown in Fig. 1.
  2. Pre-drill bracket holes with a 5/32" [4mm] drill bit. As shown in Fig. 2.
  3. Attach bracket to the posts with supplied Hex Head Self-drilling screws. 10mm Nut Driver or T-25 Bit can be used to install screws. Use low speed setting on drill. **DO NOT** over tighten screws. As shown in Fig. 3.

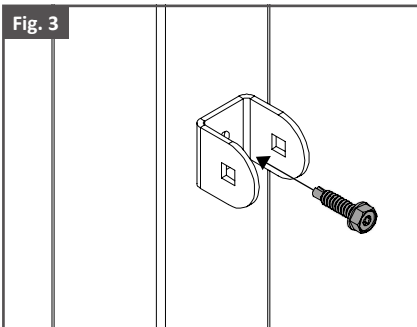
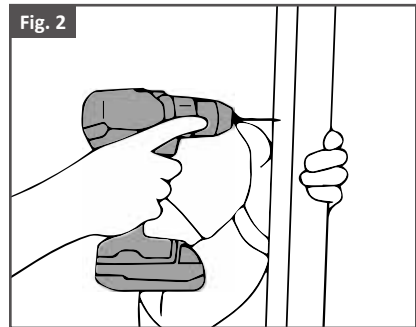
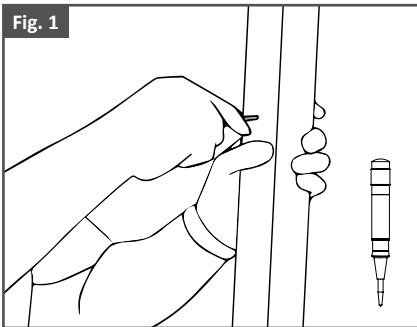

## PANEL CUTTING

### Step 1: Measure The Panel Opening Length

1. Measure the distance of the panel opening. As shown in Fig. 1.



**Tip:**

- Measure from the back wall of the bracket to the back wall of the bracket on other post. As shown in Fig. 2.
- Confirm that the length between each top, middle & bottom brackets are equal.
- Always design your layout to minimize the number of panels that need to be cut.

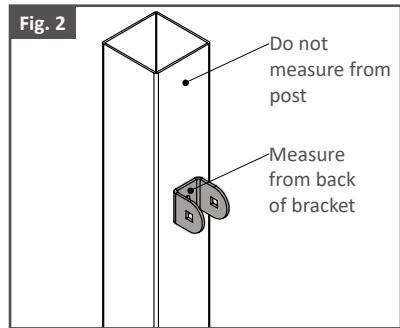
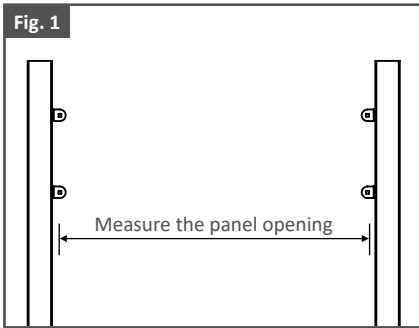

**Step 2: Mark Panel with Cut Points**

1. Use panel opening length found in step 1 above as cut length.
2. Use a tape measure to measure from center of panel and mark cut point of first end of panel. As shown in Fig. 1.
3. Use Speed Square to add mark cut points.
4. Repeat for second end of panel.

**Note:**

- When cutting a panel to length, it is recommended that an equal amount be cut from each end of panel. By doing so, this will alter the picket spacing which can affect meeting the national pool code.

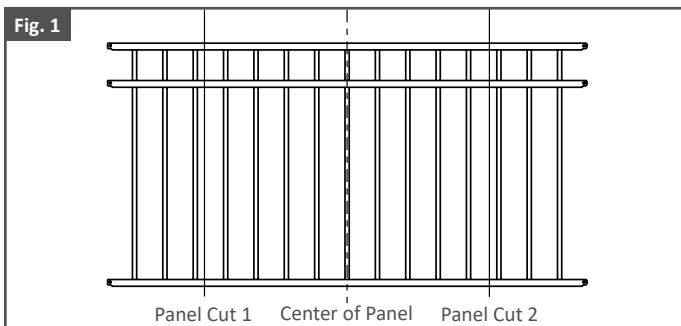

### Step 3: Cut & Clean Panels

1. Cut Panels using a Reciprocating Saw. As shown in Fig. 1.
2. Use file to smooth cut edges. As shown in Fig. 2.
3. Remove any metal shavings and dust with a brush or rag. As shown in Fig. 3.
4. Make sure surfaces to be painted are clean.

#### Tip:

- Have a second person hold down far end of panel to stop movement when cutting.

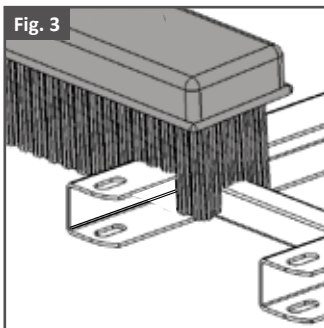
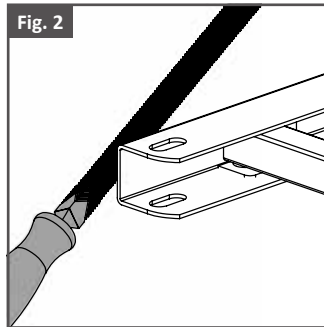
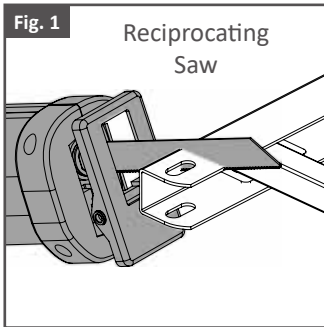

### Step 4: Apply Spray Paint To Cut Areas

1. Using a piece of cardboard as a mask, apply the 1<sup>st</sup> coat of Fortress zinc based touch-up paint.
2. Allow to dry before applying second coat.
3. Apply the 2<sup>nd</sup> coat of Fortress zinc based touch-up paint.
4. Allow to dry and install.

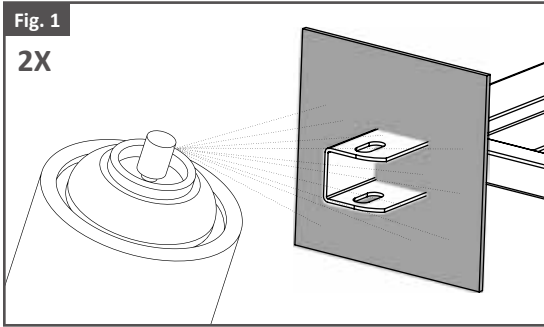

## PANEL INSTALLATION

### Step 1: Install Level Panel

1. Slide panel to the inside of mounted brackets. As shown in Fig. 1.
2. If panel was cut to length, a 5/16" [9mm] hole must be drilled in the rail.
3. Secure top, middle & bottom rail of panel using screw & bolt. As shown in Fig. 2.

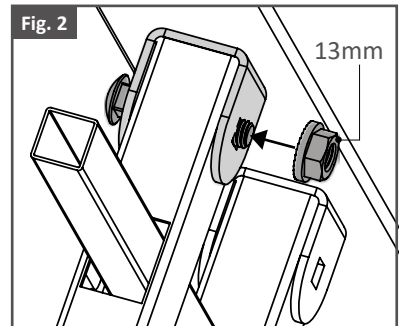
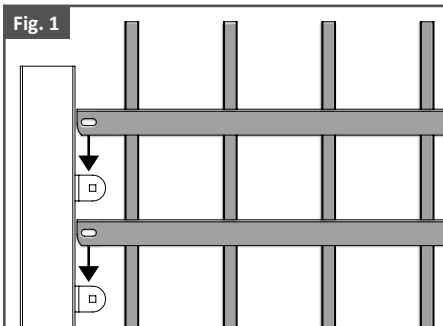

### Step 2: Install Angled Panel

1. Confirm direction of rake before installation.
2. Hang panel to the inside of mounted brackets.
3. Secure top, middle & bottom rail of panel using screw bolt.
4. If slope requires panel to be raked, install the high side of panel into post first and rake the panel down before installing in lower post. As shown in Fig. 1.

**Tip:**

- Have a second person supporting opposite end of panel.
- **DO NOT** over tighten the nut when attaching the panel to the bracket. Over tightening can result in damage to the rail.

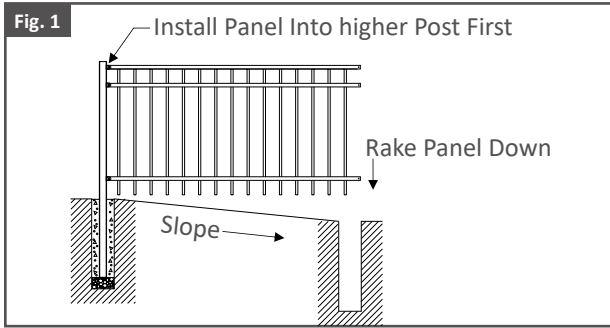

## POST CUTTING & PRESSED DOME CAP INSTALLATION

### Step 1: Trim Excess Post Material

1. Determine required post height. Post should extend 2" [50mm] above highest picket or rail. As shown in Fig. 1.
2. Make cut marks on posts.
3. Use the Reciprocating Saw or Portable Bandsaw to trim the top of the post to required height. As shown in Fig. 2.
4. Use file to clean cuts.
5. Remove any metal shavings and dust with a brush or rag.
6. Apply spray paint to cut areas. Reference step 4 of panel painting on page 19.

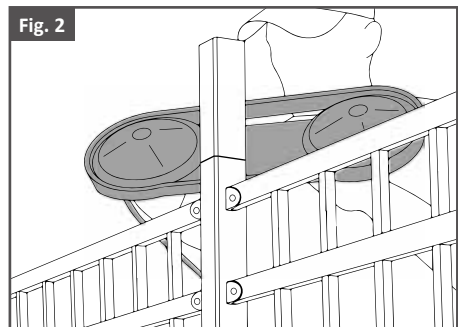
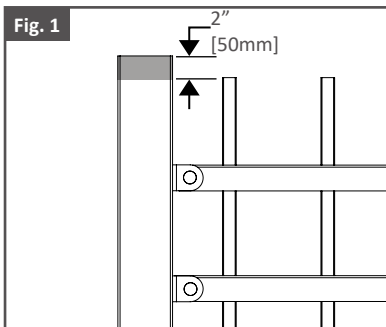

## Step 2: Install Pressed Dome Cap

1. Pressed Dome Caps & Ball Caps are press fit into place.
2. Center the Pressed Dome Cap on the post. Using a Rubber Mallet, gently tap the cap onto to post.  
As shown in Fig. 1.

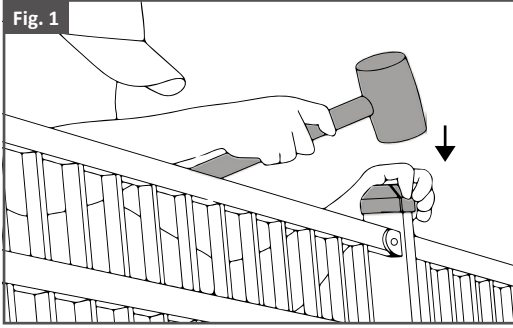

## CARE & MAINTENANCE

---

### Care And Maintenance Of Fortress Building Products Powder-Coated Products And Surfaces:

- Immediately after installation of your Fortress Building Products, clean powder-coated products and surfaces with a solution of warm water and non-abrasive, pH neutral detergent solution. Surfaces should be thoroughly rinsed after cleaning to remove all residues. All surfaces should be cleaned using a soft cloth or sponge.
- Ensure construction materials such as concrete, plaster, and paint splashes are removed immediately before they have a chance to dry. Failure to remove these materials may cause damage to the powder-coated surfaces.
- The frequency of cleaning depends in part on the standard of appearance and also the requirements to remove deposits that may cause damage to the powder coating after prolonged exposure. Fortress recommends cleaning in three to four monthly intervals all products and powder-coated
- **WARNING: Do not use strong solvents such as thinners, or solutions containing chlorinated hydrocarbons, esters, or ketones. Abrasive cleaners or cutting compounds should not be used.**

## WARRANTY

---

To obtain and review a copy of the warranty, please go to: <https://Fortressbp.com/warranties> You can also contact: (844) 909-1999 or write to: Fortress Building Products Warranty, 1720 N 1st St, Garland, TX 75040 to obtain a copy of the warranty.





**JOIN THE REVOLUTION.**

**FortressBP.com | 866.323.4766**