

ASSEMBLY INSTRUCTION | Montageanweisung | Instructions de montage | Monteringsvejledning  
Istruzioni per l'assemblaggio | 組み立て指示 (くみ立てしゅうじ) | Instrucciones de montaje

1. Please read the assembly instructions carefully before assembling and check all the parts.
2. DO NOT touch the cut surface of tube
3. Please ensure that you assemble the parts according to the assembly sequence specified in the instructions.

1. Bitte lesen Sie vor dem Zusammenbau die Montageanleitung genau durch und kontrollieren Sie alle Teile.
2. Berühren Sie die geschnittene Oberfläche des Rohres nicht.
3. Stellen Sie sicher, dass Sie die Teile nach der vorgegebenen Montagefolge zusammenbauen.

1. Veuillez lire attentivement les instructions d'assemblage avant de procéder à l'assemblage et de vérifier toutes les pièces.
2. Ne touchez pas la surface coupée du tube.
3. Assurez-vous de monter les pièces selon la séquence d'assemblage précisée.

1. Leggere attentamente le istruzioni di montaggio prima di assemblare e verificare tutti i componenti.
2. Non toccare la superficie tagliata del tubo.
3. Assicurarsi di assemblare i pezzi seguendo la sequenza di montaggio specificata.



1. 組み立てる前には、組み立て手順を注意深く読み込んで、すべてのパーツを確認してください。
2. タイプの切断面に触らないでください。
3. 指定された組み立て順序に従って、部品を正しく組み立てるようご確認ください。

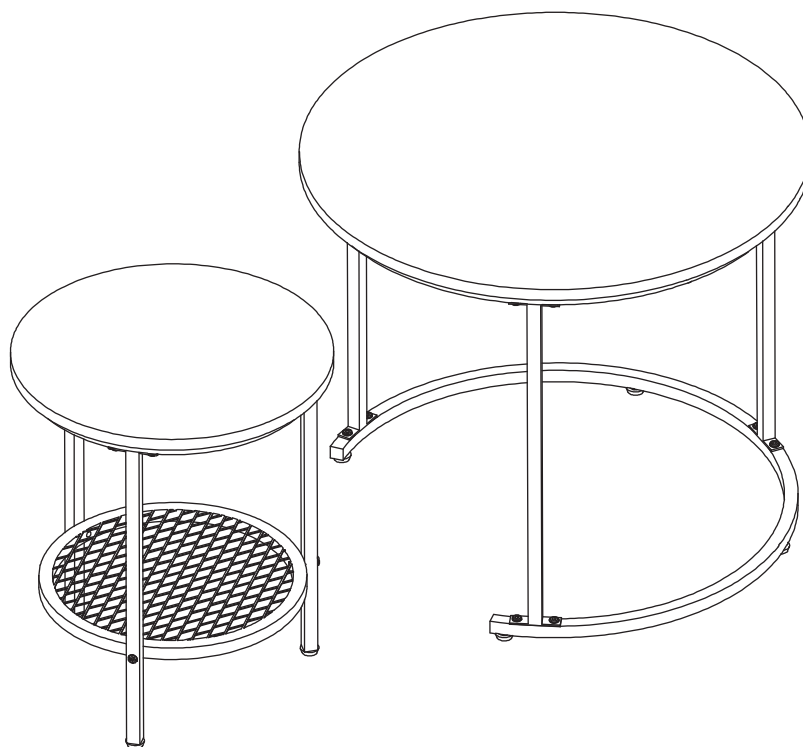

1. Por favor, lea detenidamente las instrucciones de montaje antes de ensamblar y revise todos los componentes.
2. No toque la superficie cortada del tubo.
3. Asegúrese de montar las piezas siguiendo la secuencia de montaje especificada.

1. Læs monteringsvejledningen omhyggeligt før montering og tjek alle dele.
2. Rør ikke ved den skårne overflade af røret.
3. Sørg for, at du monterer dele i den rækkefølge, der er angivet i vejledningen.

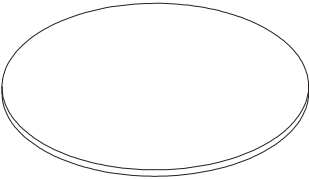
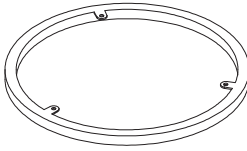
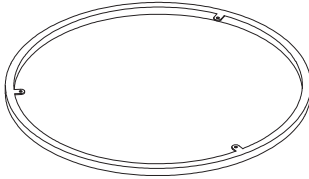
Por favor, lea cuidadosamente las instrucciones de montaje antes de montar y revise todas las piezas.  
No toque la superficie recortada del tubo.  
Asegúrese de montar las piezas de acuerdo con la secuencia de montaje especificada en las instrucciones.

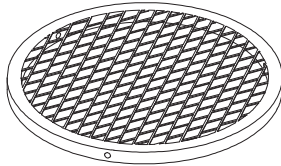
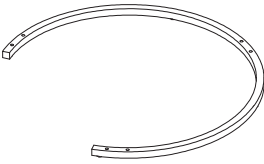
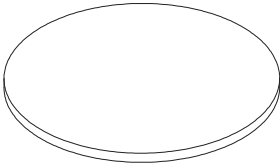

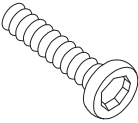
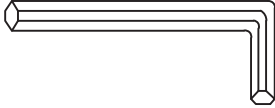
Ⓐ		X1	Ⓕ		X1
Ⓑ		X1	Ⓖ		X3
Ⓒ		X3	Ⓖ		X1
Ⓓ		X1			
Ⓔ		X1			

1	 M6x25	X3	4		
2	 M6x10	X26			
3		X7			

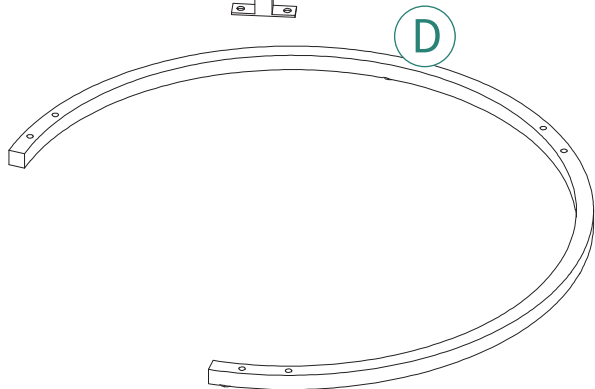
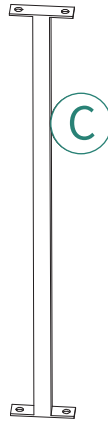
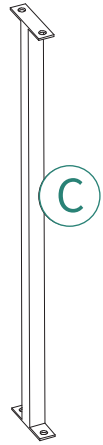
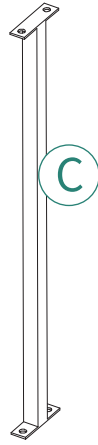
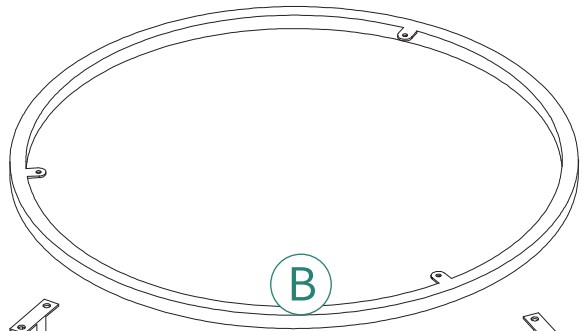
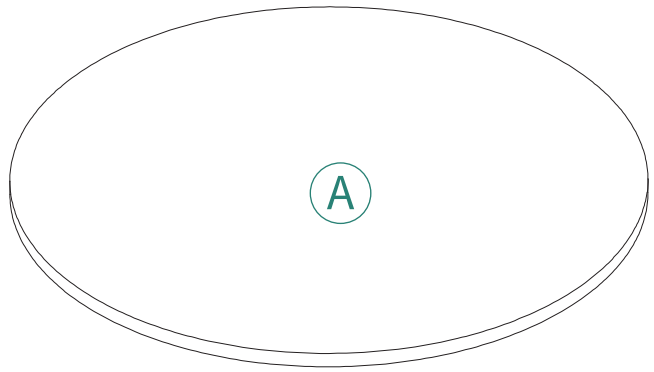
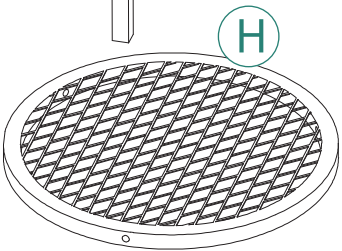
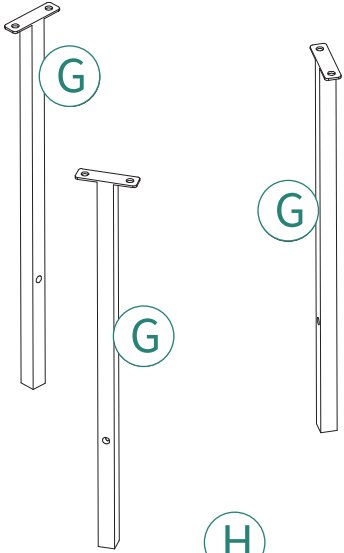
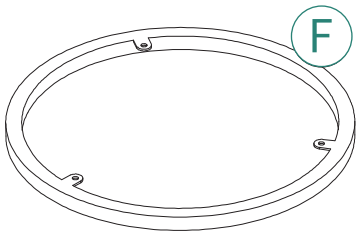
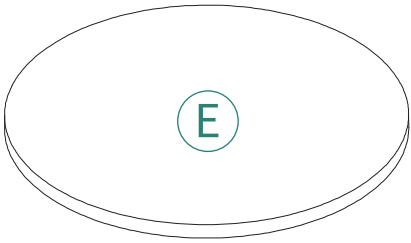

1

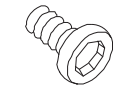

②x12



③x4



Ⓑx1





Ⓒx3

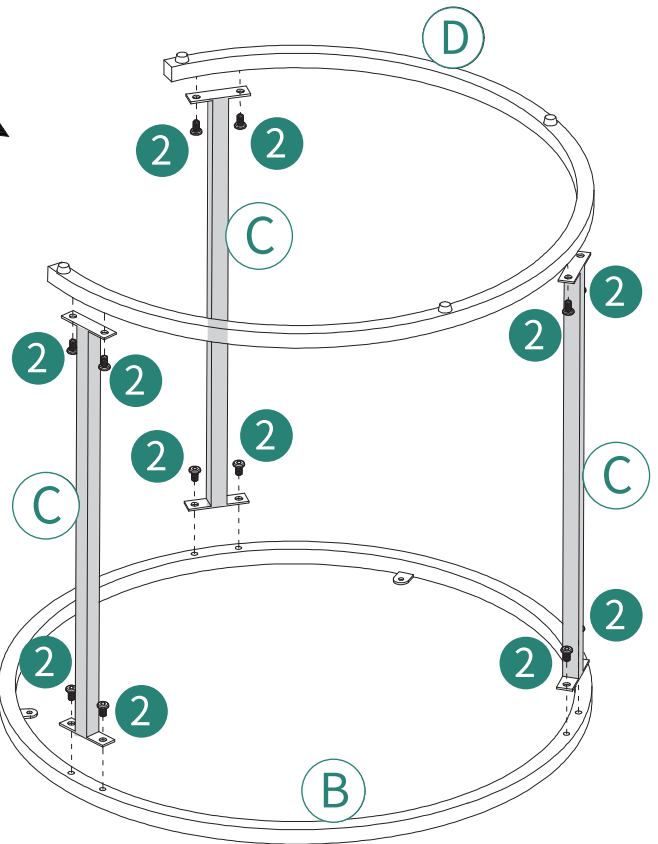
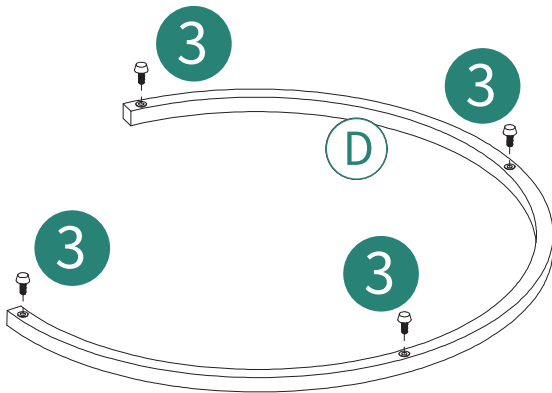

Ⓓx1



**2**

	
②x3	Ⓐx1

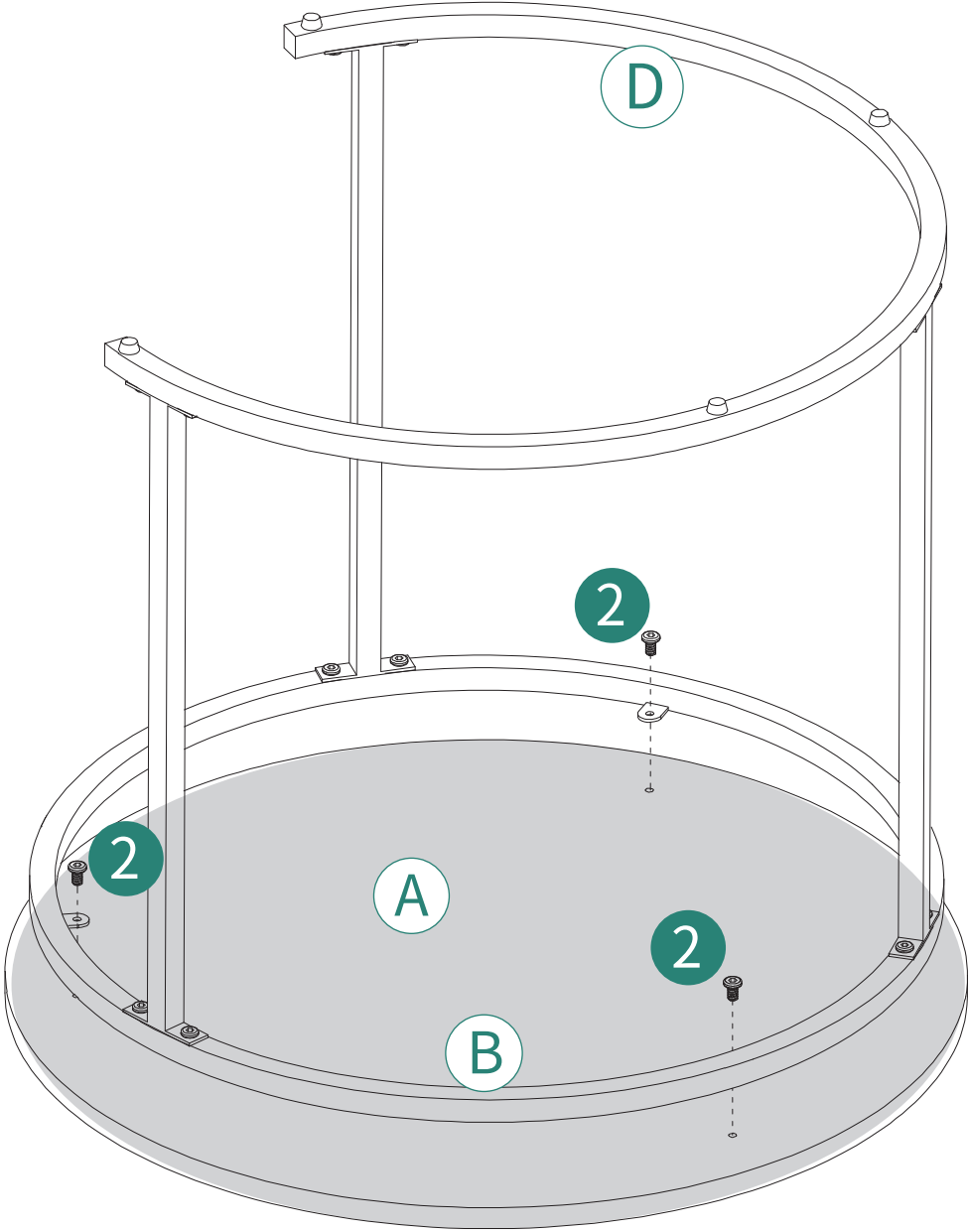

3

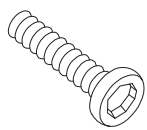

①x3



②x6



③x3

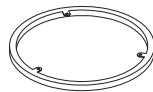

Ⓕx1



Ⓖx3

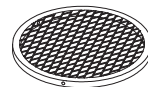

Ⓗx1

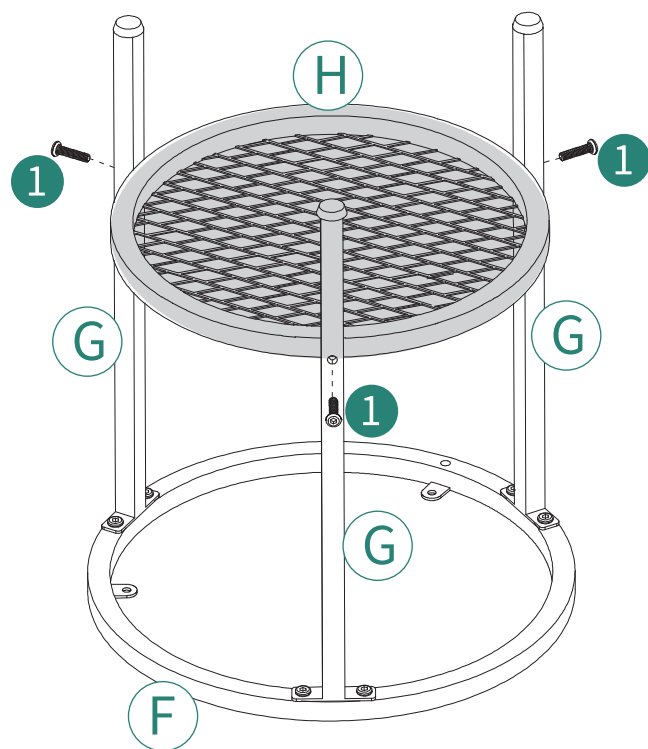
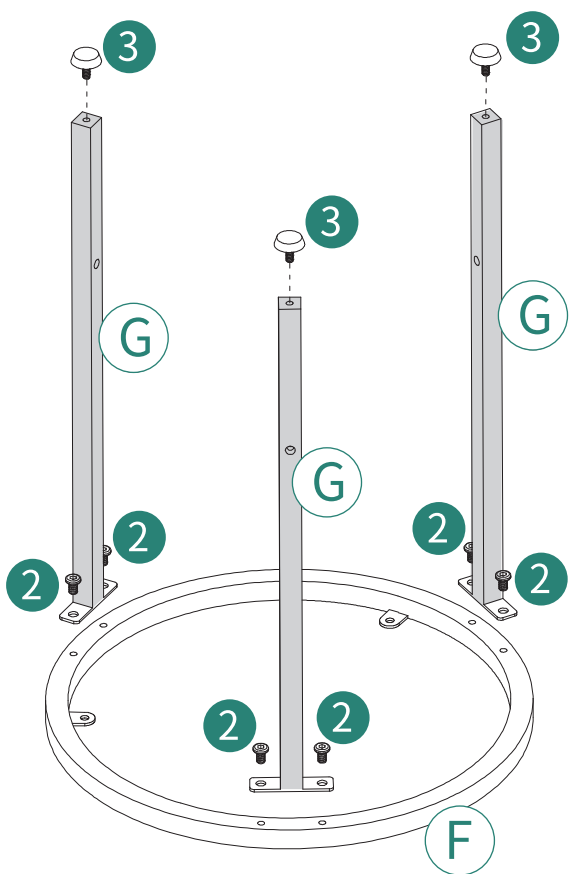

4



②x3

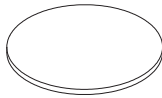

ⓔx1

